

High Wall Heat Pump System

Location:	Approval:
Engineer:	Date:
Submitted to:	Construction:
Submitted by:	Unit #:
Reference:	Drawing #:



INDOOR SPECIFICATION	
Indoor Air Flow (Turbo/H/M/L/Si) (CFM)	382.6 / 294.3 / 194.2 / 153.0 / /
Indoor Noise Level (Turbo/H/M/L/Si) (dBA)	N/A/42/35.5/22.5/20
Dimension (W×D×H)	inch 31.57 x 7.87 x 11.61
	mm 802.0×200.0×295.0
Package (W×D×H)	inch 34.45 x 11.22 x 14.96
	mm 875×285×380
Net/Gross Weight	lbs 18.96/24.25
	kg 8.6/11

OUTDOOR SPECIFICATION	
Compressor Type	ROTARY
Compressor Model	KTN110D42UFZ
Refrigerant	R454B
Refrigerant Oil Charge(mL)	350
Refrigerant Oil	VG74
Outdoor Air Flow (Max) (CFM)	1470.6
Outdoor Noise Level (dBA)	56.0
Dimension (W×D×H)	inch 31.69 x 12.99 x 21.81
	mm 805.0×330.0×554.0
Package (W×D×H)	inch 36.02 x 14.57 x 24.21
	mm 915×370×615
Net/Gross Weight	lbs 72.75/78.70
	kg 33/35.7

EFFICIENCY			
Cooling		Heating	
SEER2	24.0	HSPF2-4	10.5
EER2	13.2	COP	3.63

PERFORMANCE of Cooling	
Cooling (Btu/hr)	
Rated Capacity	12000
Min/Max Capacity	3600~13500
Moisture Removal(L/h)	1.4
Standard Operating Range(°F/°C)	-22~122(-30~50)
Conditions:	Indoor: 80°F DB/67°F WB Outdoor: 95°F DB/75°F WB

PERFORMANCE of Heating	
Heating (Btu/hr)	
1. @ 47°F Rated	12000
1. @ 47°F Min/Max Capacity	3800~16000
2. @ 17°F Rated	10000
3. @ 5°F Rated: Capacity / COP	11500/1.80
3. @ 5°F Max: Capacity	11500
Standard Operating Range(°F/°C)	-22~75(-30~24)
1. Conditions:	Indoor: 70°F DB/60°F WB Outdoor: 47°F DB/43°F WB
2. Conditions:	Indoor: 70°F DB/60°F WB Outdoor: 17°F DB/15°F WB
3. Conditions:	Indoor: 70°F DB/60°F WB Outdoor: 5°F DB/5°F WB

ELECTRICAL	
Power Supply	208/230V,60Hz,1Ph
System MCA	15.0
Connection Wiring	14#x4
System MOCP	15
Compressor RLA	11.6
Outdoor Fan Motor RLA	0.5
Outdoor Fan Motor W	34
Indoor Fan Motor RLA	0.5
Indoor Fan Motor W	13
System Power Input @ Cooling (W)	910(116 ~ 1180)
System Power Input @ Heating (W)	970(195 ~1415)
MCA: Min. circuit amps (A)	MOCP: Max. over current protection (A)
RLA: Rated load amps (A)	W: Fan motor rated output (W)

PIPING	
Throttle type(Indoor)	N/A
Throttle type(Outdoor)	EXV
Liquid Size	6.35mm(1/4in)
Gas Size	9.52mm(3/8in)
Max. Piping Length(ft/m)	82.00(25)
Max. Height Difference(ft/m)	49.20(15)
Max. Pre-charged Length(ft/m)	24.6(7.5)
Refrigerant Pre-charged Amount(oz/g)	35.27(1)
Additional Charge of Refrigerant((oz/ft)/(g/l)	0.16(15)
Connection Method	Flared

Indoor Unit Dimension

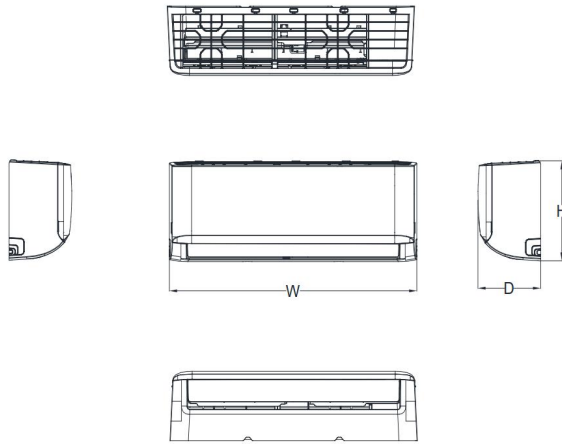

Capacity	Body Code	W(inch/mm)	D(mm/inch)	H(mm/inch)
6K~9K	A	28-3/4in /729mm	7-7/8in /200mm	11-1/2in /292mm
9K~12K	B	31-5/8in /802mm	7-7/8in /200mm	11-5/8in /295mm
18K	C	38-1/4in /971mm	9in/228mm	12-5/8in /321mm
18K~24K	D	42-5/8in /1082mm	9-1/4in/234mm	13-1/4in /337mm
30K~36K	F	49-5/8in /1259mm	11-1/8in/283mm	14-1/4in /362mm

Installation Instruction

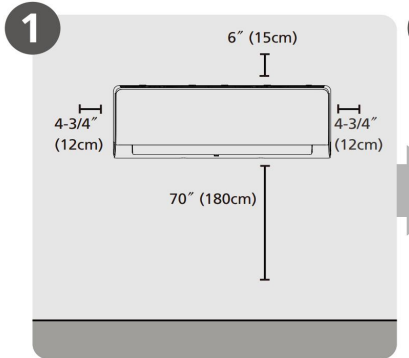

Select Installation Location

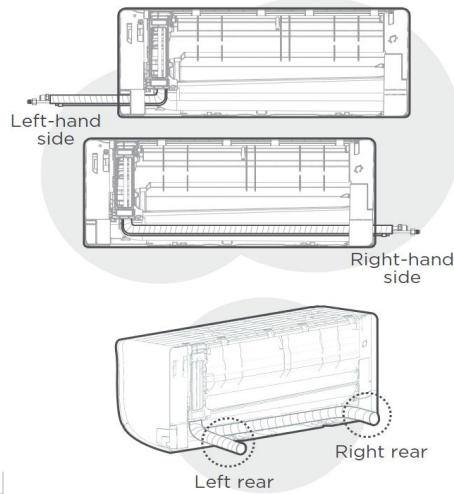

NOTE:
Based on the position of the wall hole relative to the mounting plate, choose the side from which the piping will exit the unit. You have four options for the exit direction of the piping.

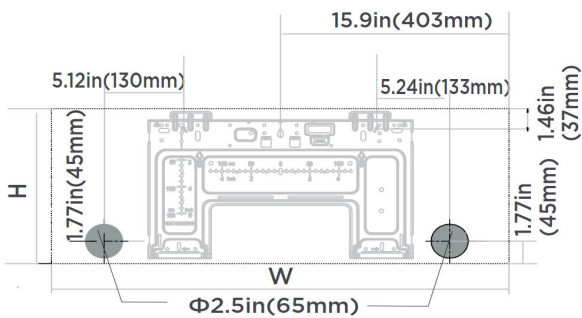

Indoor unit dimensions(WxH):
31.7in(806mm)x11.65in(296mm)

NOTE:
When the gas side connective pipe is $\Phi (5/8in)16mm$ or more, the wall hole should be $(3-1/2in)90mm$.

Outdoor Unit Dimension

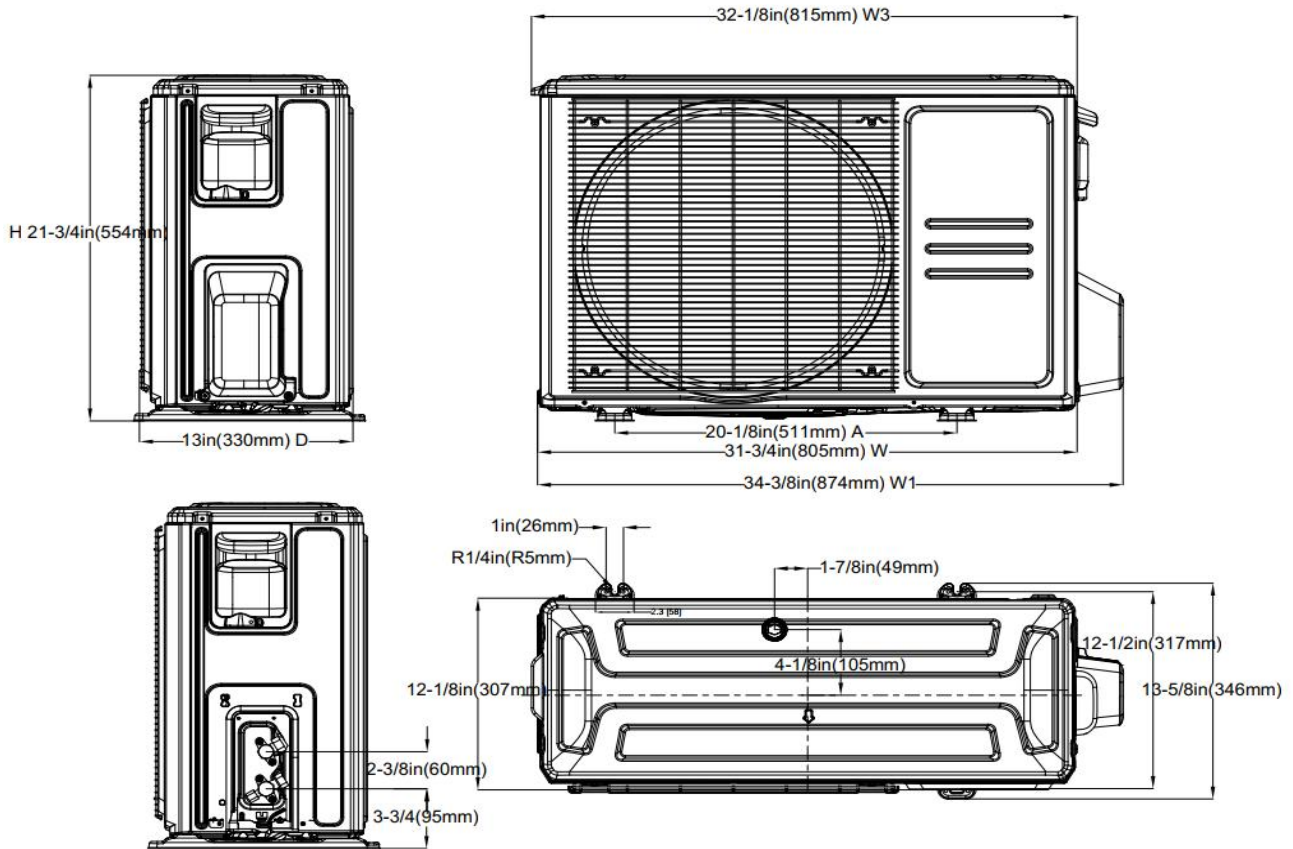

Installation Instruction

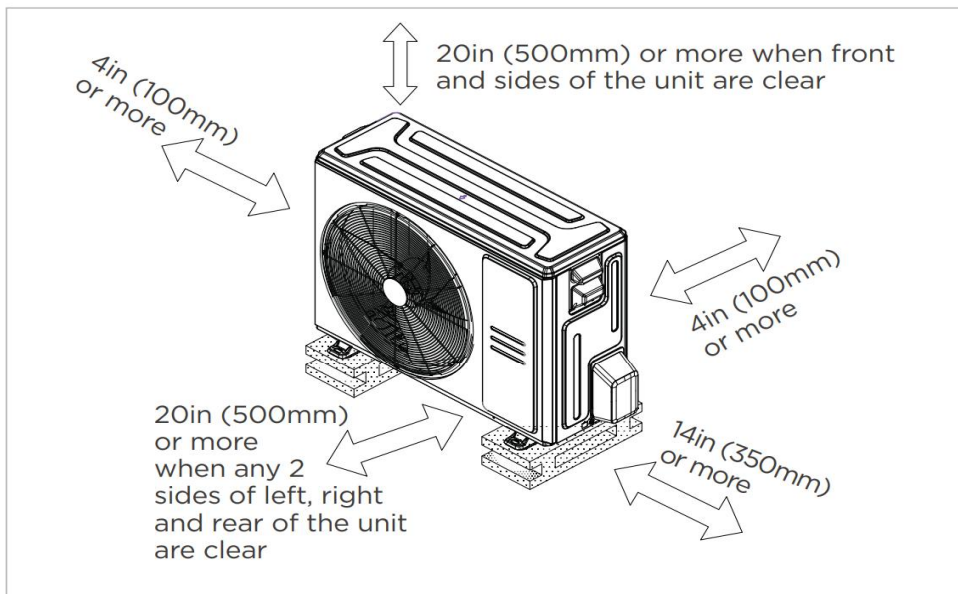

Meets all spatial requirements shown in Installation Clearance Requirements above.

FEATURES

- Indoor unit TU1 copper coil
- Humidity control
- 1~100% fan speed setting
- WiFi capability: through WiFi dongle or wired controller with built-in WiFi
- OTA(by using WiFi dongle)
- Multiple control options available:
 - Two way communication wired controller:AWC-8P-CPP*
 - Two way communication wired controller with built-in WiFi:AWC-8P-LC-WIFI
 - Infrared wired controller: AWC-4
 - Wireless remote controller
 - Third-Party 24V Thermostat

*24V interface is required.