

**Ceiling&Floor Heat Pump System**

Location:	Approval:
Engineer:	Date:
Submitted to:	Construction:
Submitted by:	Unit #:
Reference:	Drawing #:



**INDOOR SPEINDOOR SPECIFICATIONCIFICATION**

Indoor Air Flow (Turbo/H/M/L/Si) (CFM)	576.8 / 547.4 / 485.6 / 420.8 / N/A	
Indoor Noise Level (Turbo/H/M/L/Si) (dBA)	45/42.5/39.5/30.5/29.0	
Dimension (W×D×H)	inch	42.05 x 26.57 x 9.25
	mm	1068.0×675.0×235.0
Package (W×D×H)	inch	45.08 x 29.72 x 12.52
	mm	1145×755×318
Net/Gross Weight	lbs	58.42/70.55
	kg	26.5/32.0

**OUTDOOR SPECIFICATION**

Compressor Type	ROTARY	
Compressor Model	KTM240D46UKT2	
Refrigerant	R454B	
Refrigerant Oil Charge(mL)	620	
Refrigerant Oil	VG74	
Outdoor Air Flow (Max) (CFM)	1765.8	
Outdoor Noise Level (dBA)	58.0	
Dimension (W×D×H)	inch	35.04 x 13.46 x 26.50
	mm	890.0×342.0×673.0
Package (W×D×H)	inch	39.17 x 15.67 x 29.13
	mm	995×398×740
Net/Gross Weight	lbs	99.87/107.80
	kg	45.3/48.9

**EFFICIENCY**

Cooling		Heating	
SEER2	20.4	HSPF2-4	10.3
EER2	12.5	COP	3.07

**PERFORMANCE of Cooling**

Cooling (Btu/hr)	
Rated Capacity	17000
Min/Max Capacity	7400~19200
Moisture Removal(L/h)	1.73
Standard Operating Range(°F/°C)	-22~122(-30~50)
Conditions:	Indoor: 80°F DB/67°F WB Outdoor: 95°F DB/75°F WB

**PERFORMANCE of Heating**

Heating (Btu/hr)	
1. @ 47°F Rated	19000
1. @ 47°F Min/Max Capacity	8300~20700
2. @ 17°F Rated	14400
3. @ 5°F Rated: Capacity / COP	17000/1.86
3. @ 5°F Max: Capacity	17000
Standard Operating Range(°F/°C)	-22~75(-30~24)
1. Conditions:	Indoor: 70°F DB/60°F WB Outdoor: 47°F DB/43°F WB
2. Conditions:	Indoor: 70°F DB/60°F WB Outdoor: 17°F DB/15°F WB
3. Conditions:	Indoor: 70°F DB/60°F WB Outdoor: 5°F DB/5°F WB

**ELECTRICAL**

Power Supply	208/230V,60Hz,1Ph
System MCA	19.00
Connection Wiring	14#x4
System MOCP	20
Compressor RLA	11.7
Outdoor Fan Motor RLA	0.9
Outdoor Fan Motor W	80
Indoor Fan Motor RLA	1.0
Indoor Fan Motor W	90
System Power Input @ Cooling (W)	1350(500 ~ 1670)
System Power Input @ Heating (W)	1814(525 ~ 1830)
MCA: Min. circuit amps (A)	MOCP: Max. over current protection (A)
RLA: Rated load amps (A)	W: Fan motor rated output (W)

**PIPING**

Throttle type(Indoor)	N/A
Throttle type(Outdoor)	EXV+Throttle valve
Liquid Size	6.35mm(1/4in)
Gas Size	12.7mm(1/2in)
Max. Piping Length(ft/m)	98.40(30)
Max. Height Difference(ft/m)	65.60(20)
Max. Pre-charged Length(ft/m)	24.6(7.5)
Refrigerant Pre-charged Amount(oz/kg)	55.38(1.57)
Additional Charge of Refrigerant((oz/ft)/(g/m))	0.16(15)
Connection Method	Flared

## Indoor Unit Dimension

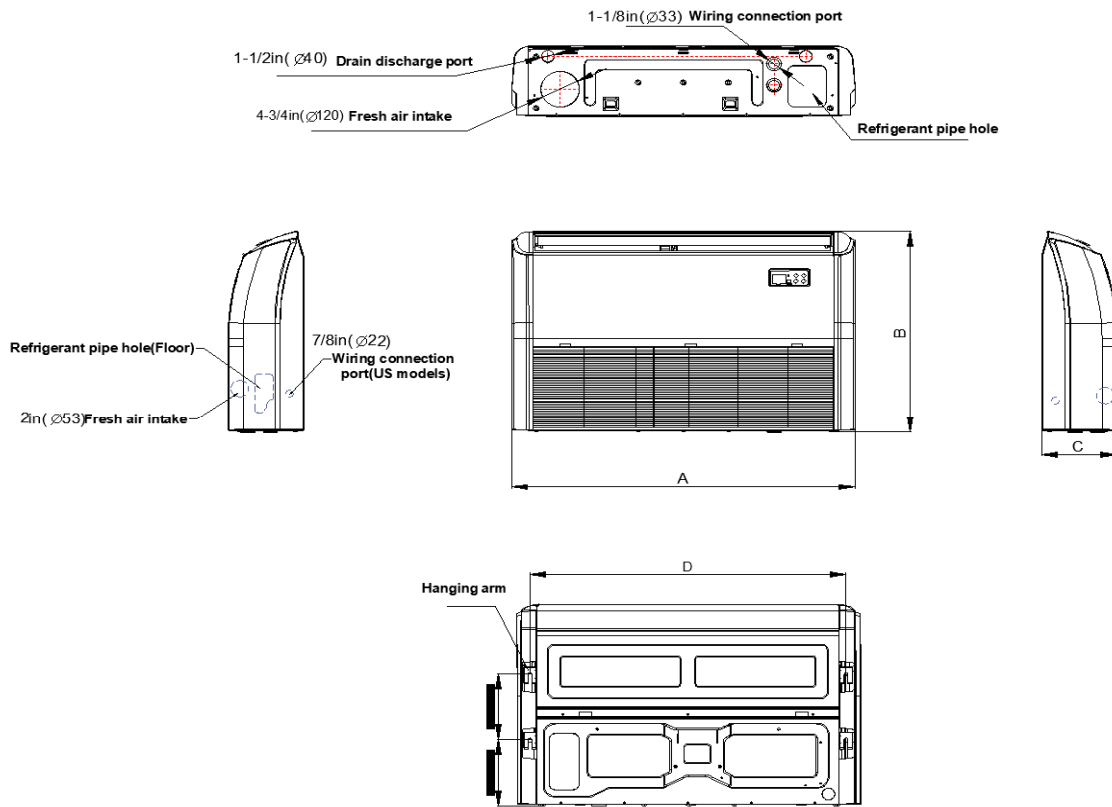

Model	A	B	C	D
18K/24K	42in(1068mm)	26-1/2in(675mm)	9-1/4in(235mm)	38-3/4in(983mm)
36K/48K/60K	65in(1650mm)	26-1/2in(675mm)	9-1/4in(235mm)	61-5/8in(1565mm)

## Installation Instruction

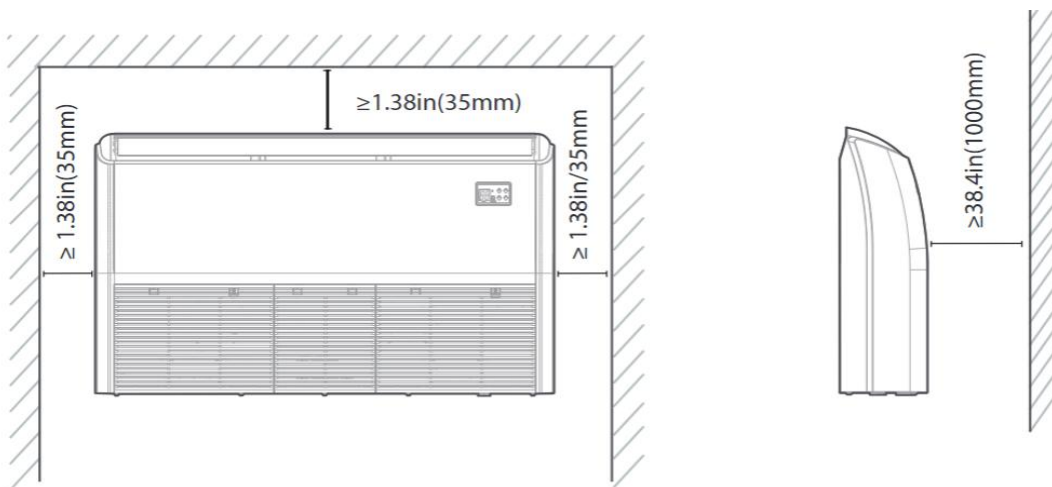

## Outdoor Unit Dimension

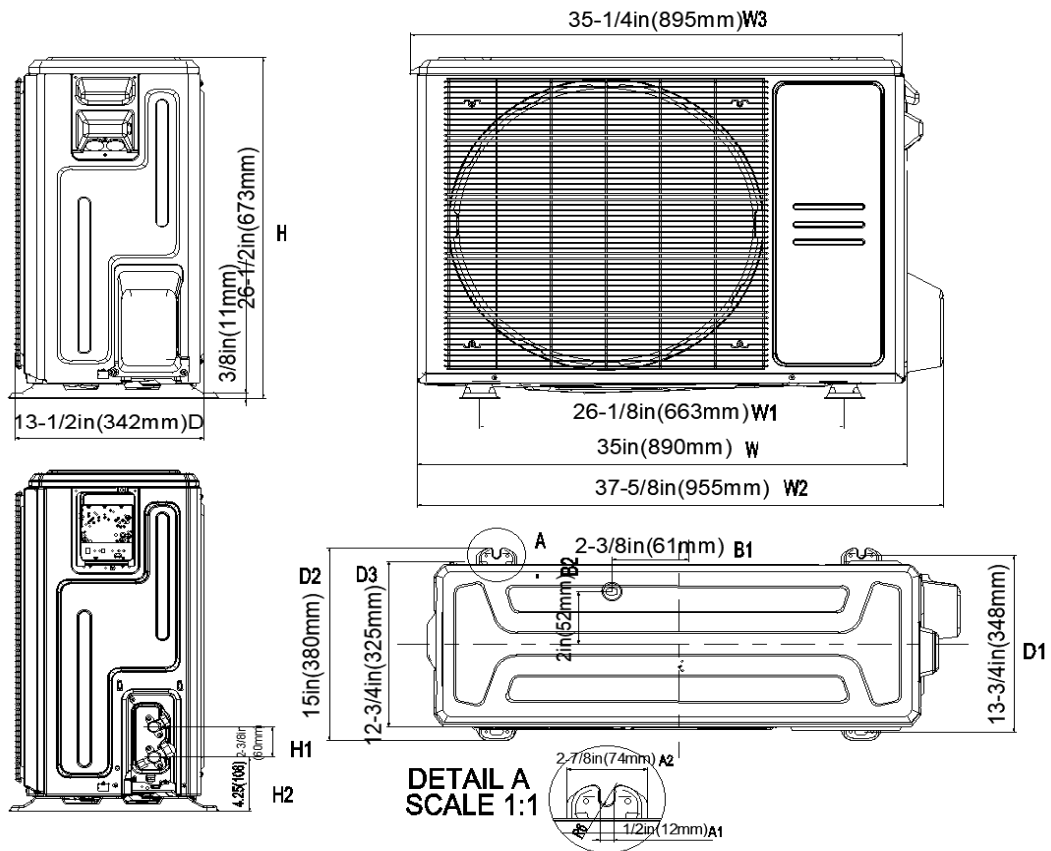

## Installation Instruction

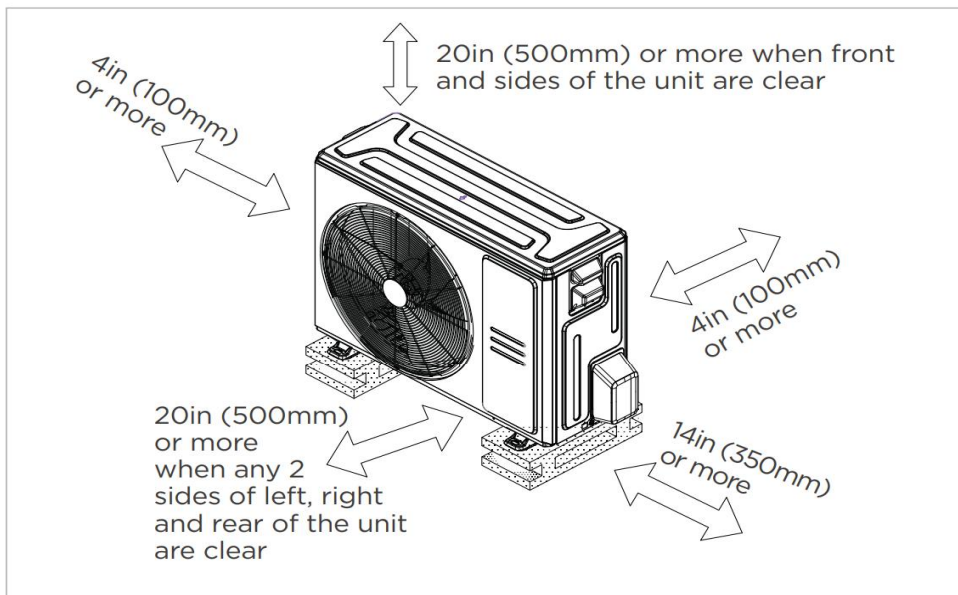

Meets all spatial requirements shown in Installation Clearance Requirements above.

## FEATURES

- 2 Style Installation
- 3D Airflow
- Refrigerant leakage detection sensor
- Humidity sensor
- “88” display tube
- 1~100% fan speed setting
- WiFi capability: through WiFi dongle or wired controller with built-in WiFi
- OTA(by using WiFi dongle)
- 2-pin connector(HA/HB) for programmable wired controller
- Multiple control options available:
  - Two way communication wired controller with built-in WiFi:AWC-8P-LC-WIFI
  - Infrared wired controller: AWC-4
  - Wireless remote controller
  - Third-Party 24V Thermostat

\*24V interface is required.