

One Way Cassette Heat Pump System

Location:	Approval:
Engineer:	Date:
Submitted to:	Construction:
Submitted by:	Unit #:
Reference:	Drawing #:



INDOOR SPEINDOOR SPECIFICATIONCIFICATION

Indoor Air Flow (Turbo/H/M/L/Si) (CFM)	341.4 / 294.3 / 259.0 / 235.4 / N/A	
Indoor Noise Level (Turbo/H/M/L/Si) (dBA)	46.5/38.5/34.0/24.0/22.0	
Dimension (W×D×H)	inch	50.31 x 13.19 x 8.98
	mm	1278.0×335.0×228.0
Package (W×D×H)	inch	57.60 x 22.48 x 22.64
	mm	1463×571×575
Net/Gross Weight	lbs	45.19/82.45
	kg	20.5/37.4

OUTDOOR SPECIFICATION

Compressor Type	ROTARY	
Compressor Model	KSK103D33UEZ3	
Refrigerant	R454B	
Refrigerant Oil Charge(mL)	310	
Refrigerant Oil	VG74	
Outdoor Air Flow (Max) (CFM)	1236.1	
Outdoor Noise Level (dBA)	54.5	
Dimension (W×D×H)	inch	30.12 x 11.93 x 21.85
	mm	765.0×303.0×555.0
Package (W×D×H)	inch	34.92 x 13.27 x 24.02
	mm	887×337×610
Net/Gross Weight	lbs	62.17/67.68
	kg	28.2/30.7

EFFICIENCY

Cooling		Heating	
SEER2	22.1	HSPF2-4	11.8
EER2	14.4	COP	3.20

PERFORMANCE of Cooling

Cooling (Btu/hr)	
Rated Capacity	9000
Min/Max Capacity	3700~11400
Moisture Removal(L/h)	1.00
Standard Operating Range(°F/°C)	-13~122(-25~50)
Conditions:	Indoor: 80°F DB/67°F WB Outdoor: 95°F DB/75°F WB

PERFORMANCE of Heating

Heating (Btu/hr)	
1. @ 47°F Rated	11000
1. @ 47°F Min/Max Capacity	4100~14300
2. @ 17°F Rated	7900
3. @ 5°F Rated: Capacity / COP	8000/2.18
3. @ 5°F Max: Capacity	8000
Standard Operating Range(°F/°C)	-13~75(-25~24)
1. Conditions:	Indoor: 70°F DB/60°F WB Outdoor: 47°F DB/43°F WB
2. Conditions:	Indoor: 70°F DB/60°F WB Outdoor: 17°F DB/15°F WB
3. Conditions:	Indoor: 70°F DB/60°F WB Outdoor: 5°F DB/5°F WB

ELECTRICAL

Power Supply	208/230V,60Hz,1Ph
System MCA	12.00
Connection Wiring	14#x4
System MOCP	15
Compressor RLA	7.3
Outdoor Fan Motor RLA	0.6
Outdoor Fan Motor W	34
Indoor Fan Motor RLA	0.8
Indoor Fan Motor W	30
System Power Input @ Cooling (W)	625(220 ~ 990)
System Power Input @ Heating (W)	1007(265 ~ 1310)
MCA: Min. circuit amps (A)	MOCP: Max. over current protection (A)
RLA: Rated load amps (A)	W: Fan motor rated output (W)

PIPING

Throttle type(Indoor)	N/A
Throttle type(Outdoor)	EXV
Liquid Size	6.35mm(1/4in)
Gas Size	9.52mm(3/8in)
Max. Piping Length(ft/m)	82.00(25)
Max. Height Difference(ft/m)	49.20(15)
Max. Pre-charged Length(ft/m)	24.6(7.5)
Refrigerant Pre-charged Amount(oz/kg)	32.45(0.92)
Additional Charge of Refrigerant((oz/ft)/(g/m))	0.16(15)
Connection Method	Flared

Indoor Unit Dimension

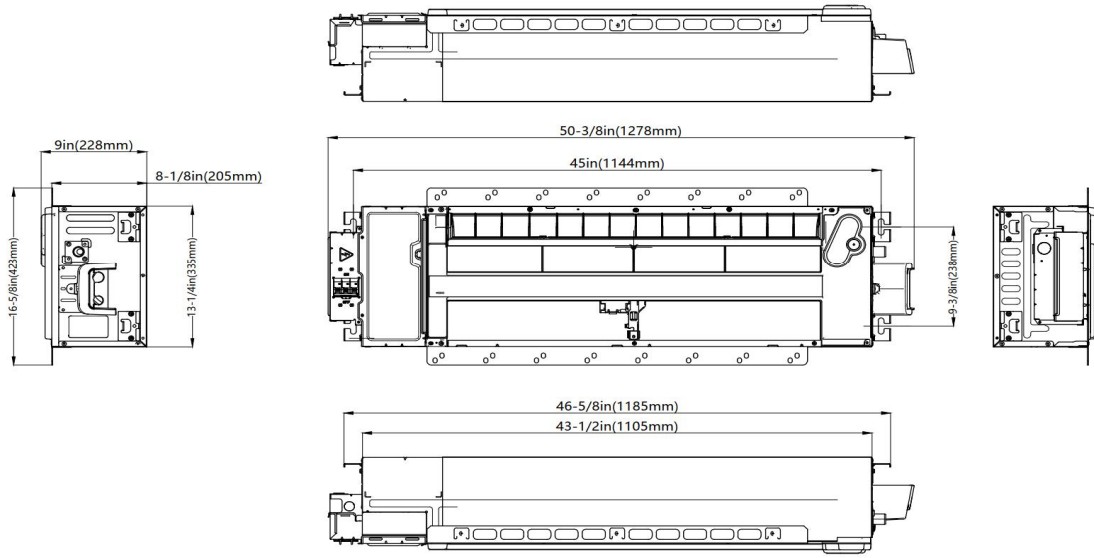

Installation Instruction

Installation place

(unit: inch/mm)

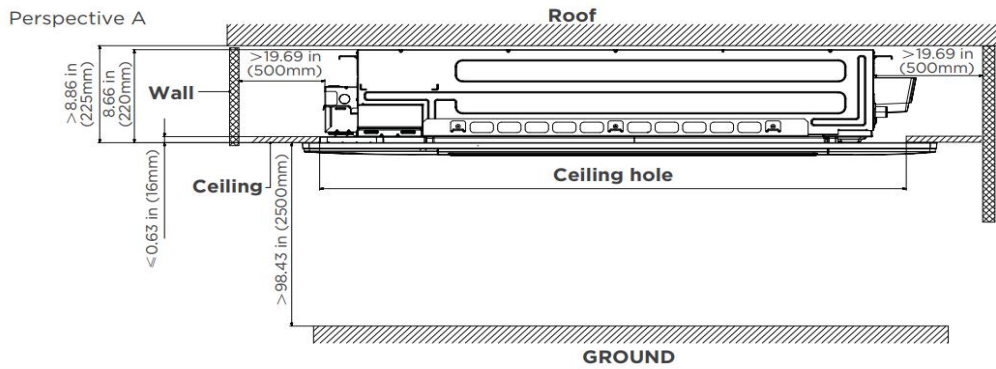

Perspective B

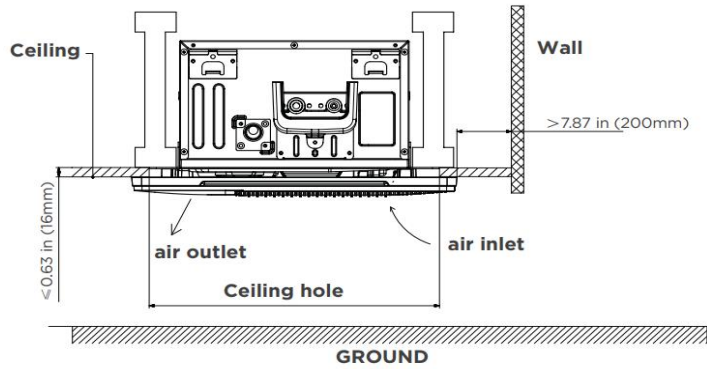

Outdoor Unit Dimension

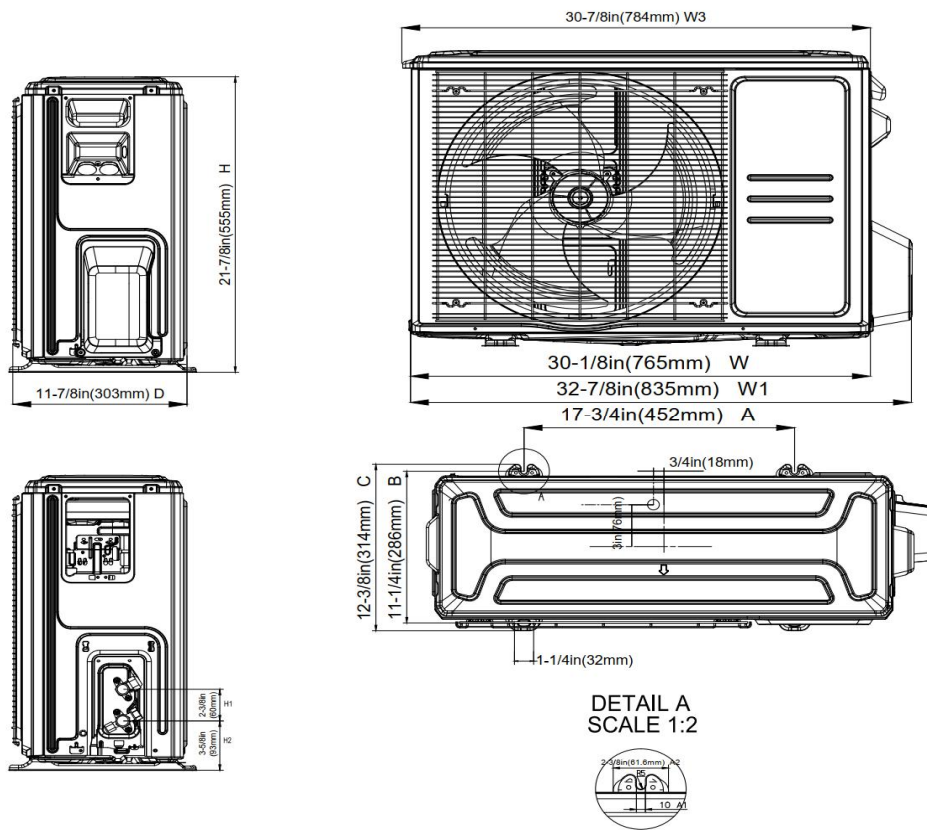

Installation Instruction

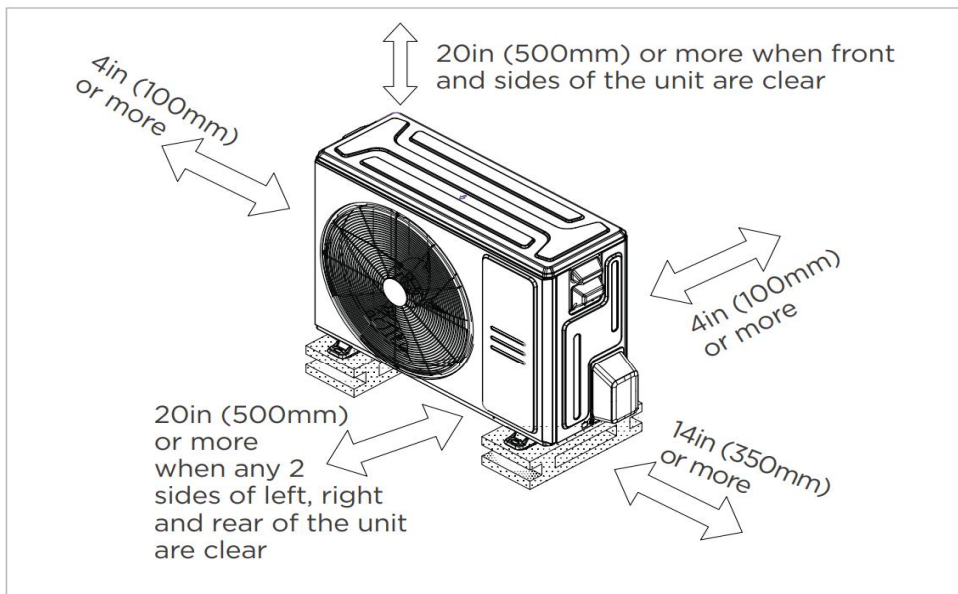

Meets all spatial requirements shown in Installation Clearance Requirements above.

FEATURES

- Designed to fit between both I-joint spacing and traditional joist spacing
- Elevation panel
- Refrigerant leakage detection sensor(Optional)
- Humidity sensor
- Built-in pump
- Built-in circuit breaker
- 1~100% fan speed setting
- WiFi capability: through WiFi dongle or wired controller with built-in WiFi
- OTA(by using WiFi dongle)
- 2-pin connector(HA/HB) for programmable wired controller
- Multiple control options available:
 - Two way communication wired controller with built-in WiFi:AWC-8P-LC-WIFI
 - Infrared wired controller: AWC-4 (standard)
 - Wireless remote controller
 - Third-Party 24V Thermostat

*24V interface is required.