

Air Handler Heat Pump System

Location:	Approval:
Engineer:	Date:
Submitted to:	Construction:
Submitted by:	Unit #:
Reference:	Drawing #:



INDOOR SPEINDOOR SPECIFICATIONCIFICATION

Indoor Air Flow (Turbo/H/M/L/Si) (CFM)	1189.0 / 1083.0 / 971.2 / 865.2 / N/A	
Indoor Noise Level (Turbo/H/M/L/Si) (dBA)	N/A/48/45/31/N/A	
Dimension (W×D×H)	inch	21.02 x 21.02 x 49.02
	mm	534.0×534.0×1245.0
Package (W×D×H)	inch	26.57 x 24.41 x 52.56
	mm	675×620×1335
Net/Gross Weight	lbs	127.87/154.10
	kg	58/69.9

OUTDOOR SPECIFICATION

Compressor Type	ROTARY	
Compressor Model	KTF250D22UMT	
Refrigerant	R454B	
Refrigerant Oil Charge(mL)	670	
Refrigerant Oil	VG74	
Outdoor Air Flow (Max) (CFM)	2236.7	
Outdoor Noise Level (dBA)	63	
Dimension (W×D×H)	inch	37.24 x 16.14 x 31.89
	mm	946.0×410.0×810.0
Package (W×D×H)	inch	42.91 x 19.68 x 34.84
	mm	1090×500×885
Net/Gross Weight	lbs	150.35/160.27
	kg	68.2/72.7

EFFICIENCY

Cooling		Heating	
SEER2	16	HSPF2-4	7.7
EER2	8.5	COP	3.2

PERFORMANCE of Cooling

Cooling (Btu/hr)	
Rated Capacity	36000
Min/Max Capacity	10600~37700
Moisture Removal(L/h)	3.12
Standard Operating Range(°F/°C)	-13~122(-25~50)
Conditions:	Indoor: 80°F DB/67°F WB Outdoor: 95°F DB/75°F WB

PERFORMANCE of Heating

Heating (Btu/hr)	
1. @ 47°F Rated	37000
1. @ 47°F Min/Max Capacity	5000~38800
2. @ 17°F Rated	17900
3. @ 5°F Rated: Capacity / COP	23000/2
3. @ 5°F Max: Capacity	23000
Standard Operating Range(°F/°C)	-13~75(-25~24)
1. Conditions:	Indoor: 70°F DB/60°F WB Outdoor: 47°F DB/43°F WB
2. Conditions:	Indoor: 70°F DB/60°F WB Outdoor: 17°F DB/15°F WB
3. Conditions:	Indoor: 70°F DB/60°F WB Outdoor: 5°F DB/5°F WB

ELECTRICAL

Power Supply	208/230V,60Hz,1Ph
System MCA	33
Connection Wiring	AWG 14-4
System MOCP	35
Compressor RLA	21.5
Outdoor Fan Motor RLA	1.3
Outdoor Fan Motor W	120
Indoor Fan Motor RLA	4.5
Indoor Fan Motor W	375
System Power Input @ Cooling (W)	4186(910 ~ 4630)
System Power Input @ Heating (W)	3390(470 ~3530)
MCA: Min. circuit amps (A)	MOCP: Max. over current protection (A)
RLA: Rated load amps (A)	W: Fan motor rated output (W)

PIPING

Throttle type(Indoor)	N/A
Throttle type(Outdoor)	EXV+Throttle valve
Liquid Size	9.52mm(3/8in)
Gas Size	15.9mm(5/8in)
Max. Piping Length(ft/m)	213.3(65)
Max. Height Difference(ft/m)	98.4(30)
Max. Pre-charged Length(ft/m)	24.6(7.5)
Refrigerant Pre-charged Amount(oz/kg)	112.88(3.2)
Additional Charge of Refrigerant((oz/ft)/(g/m))	0.32(30)
Connection Method	Flared

Indoor Unit Dimension

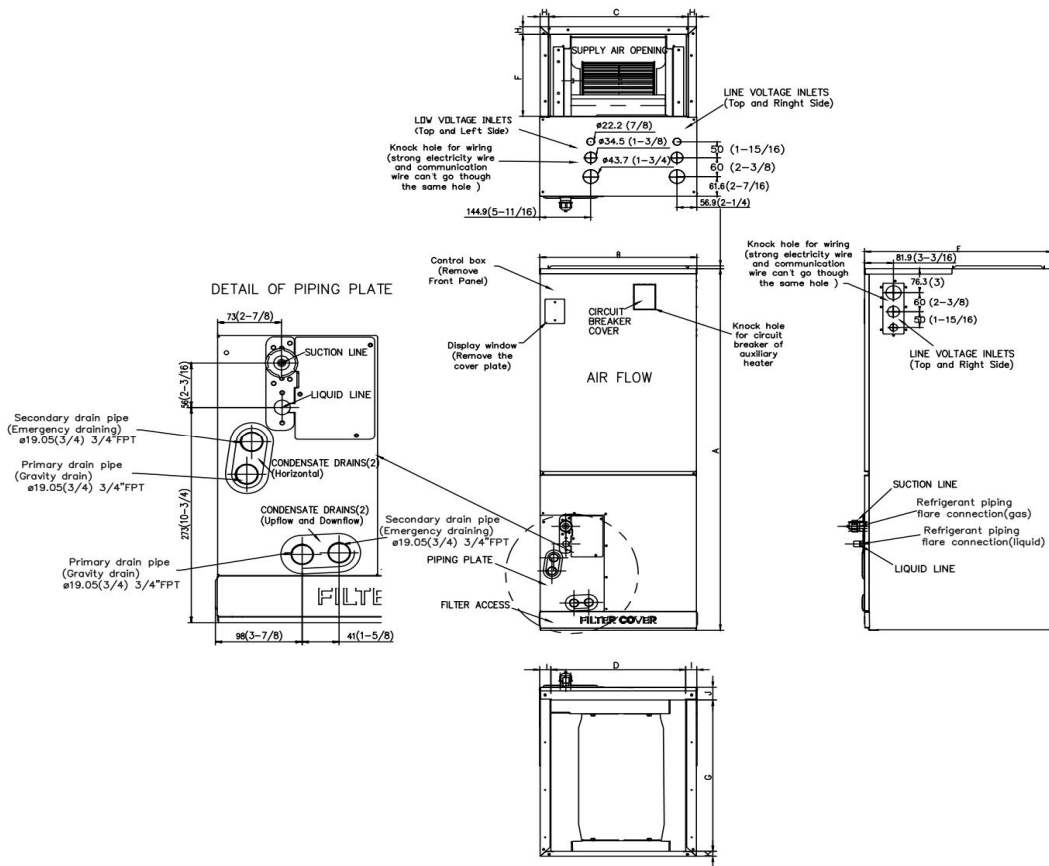

Dimensions	Model	18k/24k		30k/36k		48k/60k	
		inch	mm	inch	mm	inch	mm
A	Model Height	45	1143	49	1245	53	1346
B	Model Width	17-1/2	445	21	534	24-1/2	622
C	Supply Air Opening Width	15-5/8	397	19-1/8	486	22-5/8	575
D	Return Air Opening Width	15-1/8	384	18-5/8	473	22-1/8	562
E	Model Depth	21	534	21	534	21	534
F	Supply Air Opening Depth	10-1/4	260	10-1/4	260	10-1/4	260
G	Return Air Opening Depth	18-3/4	476	18-3/4	476	18-3/4	476
H	Supply Air Opening Clearance	15/16	24	15/16	24	15/16	24
I	Return Air Opening Side Clearance	1-1/4	32	1-1/4	32	1-1/8	28
J	Return Air Opening Front Clearance	1-1/2	38	1-5/8	41	1-5/8	41
K	Return Air Opening Back Clearance	5/8	16	5/8	16	3/4	19

Outdoor Unit Dimension

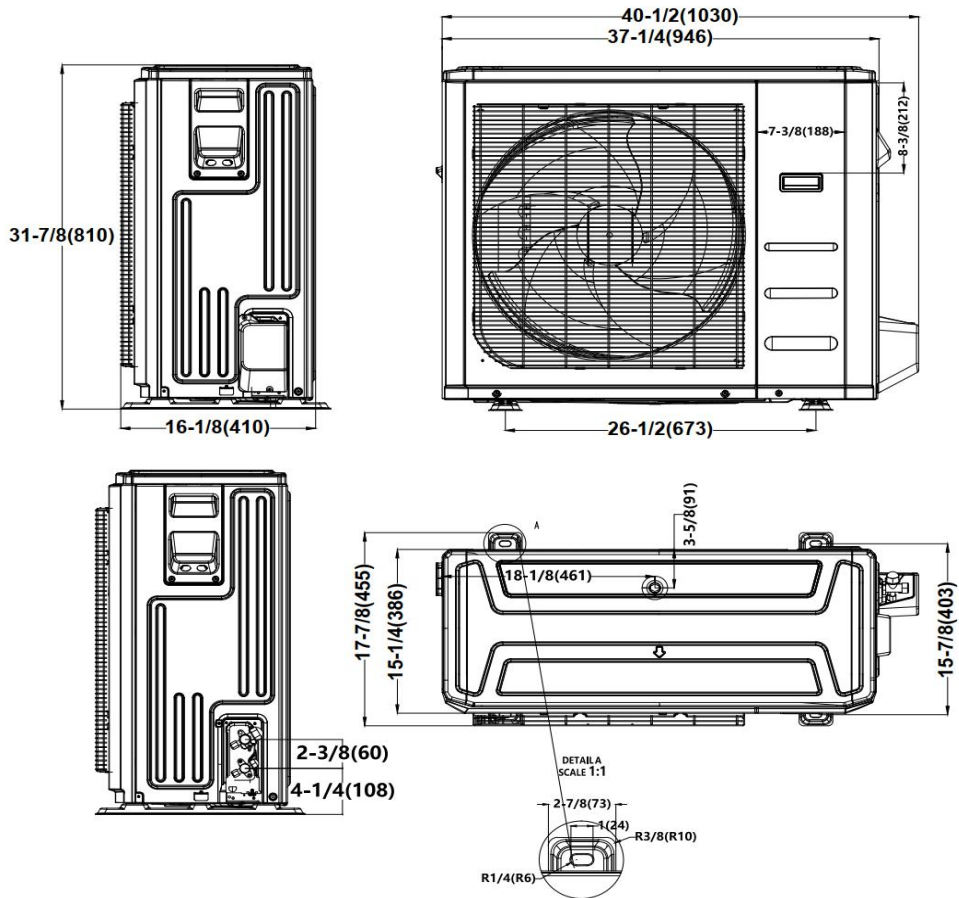

Installation Instruction

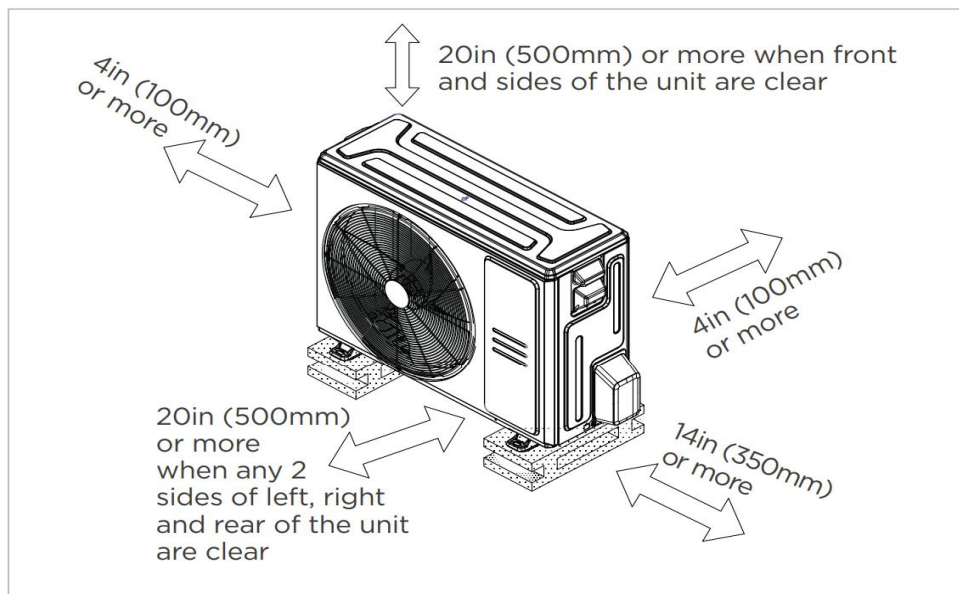

Meets all spatial requirements shown in Installation Clearance Requirements above.

Fan Performance For Indoor Unit

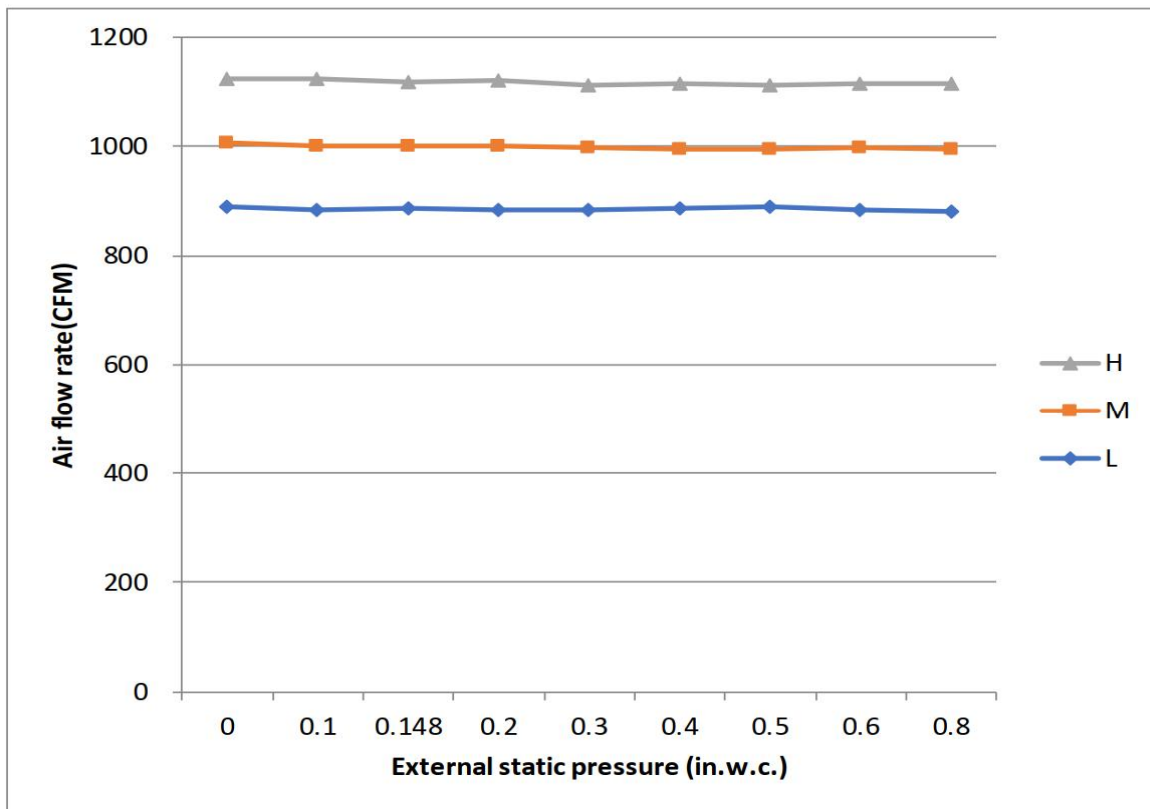

Features

- Multi-position installation: horizontal(left or right), vertical(up or down)
- Aluminum Coil
- Constantly Air Flow system up to 0.80 In.W.G
- 1 inch R4.2 fiberglass free insulation reduces condensation and boosts efficiency(optional)
- Optional Auxiliary heat kit up to 25kW
- Easy Maintenance
- Multiple control options available:
 - Two way communication wired controller with built-in WiFi:AWC-8P-LC-WIFI
 - Wireless remote controller
 - Third-Party 24V Thermostat
- High efficiency up to 19.7 SEER2, 12.1 EER2, 9.8 HSPF2
- Chassis heater and crankcase heater equipped as standard