

**Multi Zone Heat Pump System**

Location:	Approval:
Engineer:	Date:
Submitted to:	Construction:
Submitted by:	Unit #:
Reference:	Drawing #:



**OUTDOOR SPECIFICATION**

<b>Compressor Type</b>	ROTARY	
<b>Compressor Model</b>	KTQ420D1UMU	
<b>Refrigerant</b>	R454B	
<b>Refrigerant Oil Charge(mL)</b>	1400	
<b>Refrigerant Oil</b>	V74	
<b>Outdoor Air Flow (Max) (CFM)</b>	4503	
<b>Outdoor Noise Level (dBA)</b>	65	
<b>Dimension (W×D×H)</b>	inch	37.48 x 16.34 x 52.48
	mm	952×415×1333
<b>Package (W×D×H)</b>	inch	43.11 x 19.49 x 58.27
	mm	1095×495×1480
<b>Net/Gross Weight</b>	lbs	237.88/270.28
	kg	107.9/122.6

**ELECTRICAL**

<b>Power Supply</b>	208/230V,60Hz,1Ph
<b>System MCA</b>	36
<b>Connection Wiring</b>	AWG 14-4
<b>System MOCP</b>	40
<b>Compressor RLA</b>	25
<b>Outdoor Fan Motor RLA</b>	2.5
<b>Outdoor Fan Motor W</b>	85
<b>Indoor Fan Motor RLA</b>	/
<b>Indoor Fan Motor W</b>	/
<b>System Power Input @ Cooling (W)</b>	6000/(1200 ~ 5900)
<b>System Power Input @ Heating (W)</b>	5024/(1200 ~ 5200)
<b>MCA:</b> Min. circuit amps (A)	<b>MOCP:</b> Max. over current protection (A)
<b>RLA:</b> Rated load amps (A)	<b>W:</b> Fan motor rated output (W)

**EFFICIENCY**

Cooling		Heating	
<b>SEER2</b>	19.2	<b>HSPF2-4</b>	9.6
<b>EER2</b>	10	<b>COP</b>	3.5

**PERFORMANCE of Cooling**

Cooling (Btu/hr)	
<b>Rated Capacity</b>	60000
<b>Min/Max Capacity</b>	19000~62000
<b>Moisture Removal(L/h)</b>	5.6
<b>Standard Operating Range(°F/°C)</b>	-13~122/(-25~50)
Rated Cooling Conditions: Indoor: 80°F DB/67°F WB Outdoor: 95°F DB/75°F WB	

**PERFORMANCE of Heating**

Heating (Btu/hr)	
<b>1. @ 47°F Rated</b>	60000
<b>1. @ 47°F Min/Max Capacity</b>	20000~60000
<b>2. @ 17°F Rated(H32)</b>	39000
<b>3. @ 5°F Rated: Capacity / COP(H42)</b>	36000/2
<b>3. @ 5°F Max: Capacity</b>	36000
<b>Standard Operating Range(°F/°C)</b>	-13~75/(-25~24)
1. Conditions: Indoor: 70°F DB/60°F WB Outdoor: 47°F DB/43°F WB	
2. Conditions: Indoor: 70°F DB/60°F WB Outdoor: 17°F DB/15°F WB	
3. Conditions: Indoor: 70°F DB/60°F WB Outdoor: 5°F DB/5°F WB	

**PIPING**

<b>Liquid Size</b>	6x6.35mm(6x1/4in)
<b>Gas Size</b>	4x9.52mm+2x12.7mm
<b>Max. Piping Length for all rooms(ft/m)</b>	262.4/(80)
<b>Max. Piping Length for one IDU(ft/m)</b>	114.8/(35)
<b>Max. Height Difference of IDU and ODU(ft/m)</b>	49.2/(15)
<b>Refrigerant Pre-charged Amount(oz/kg)</b>	151.68/(4.3)
<b>Refrigerant Precharge Length(ft/m)</b>	24.6(7.5)x6
<b>Additional Charge of Refrigerant (Φ6.35 (1/4") liquid pipe) ((oz/ft)/(g/m))</b>	0.16/(15)
<b>Additional Charge of Refrigerant (Φ9.52 (3/8") liquid pipe) ((oz/ft)/(g/m))</b>	0.32(30)
<b>Connection Method</b>	Flared

### Outdoor Unit Dimension

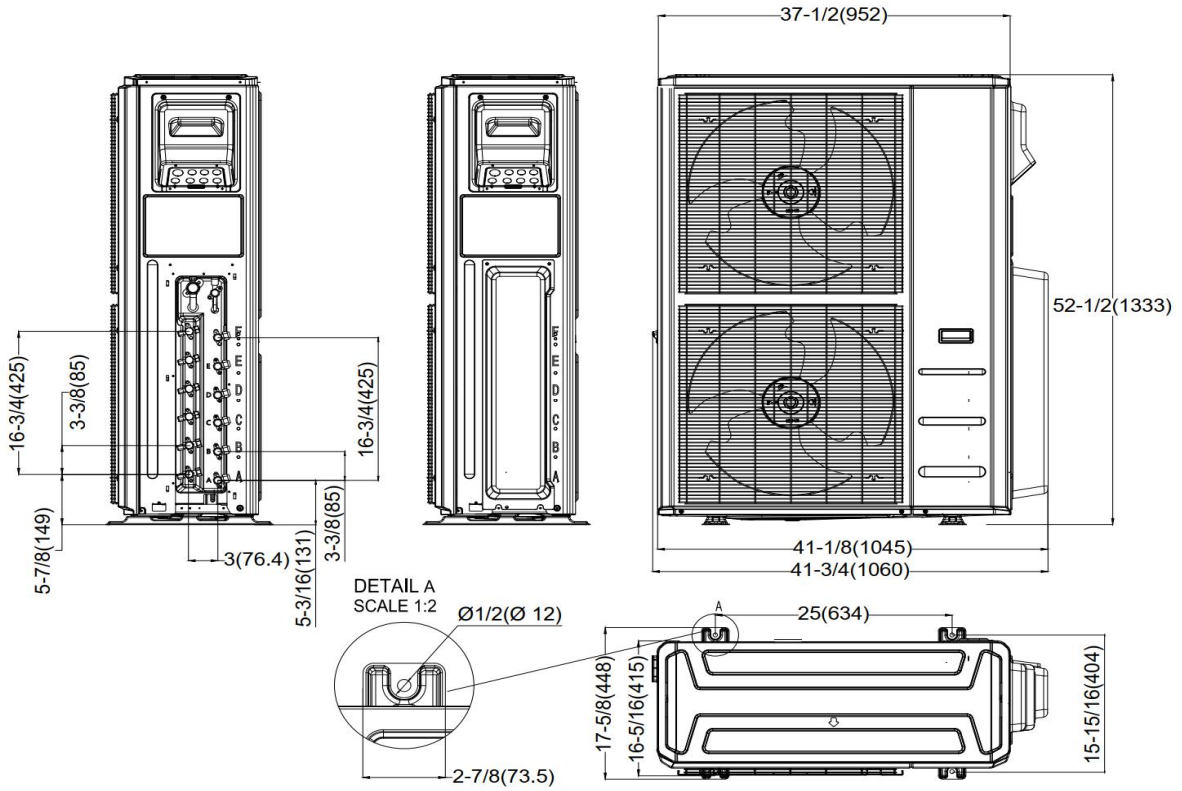

### Installation Instruction

