

Slim Duct Heat Pump System

Location:	Approval:
Engineer:	Date:
Submitted to:	Construction:
Submitted by:	Unit #:
Reference:	Drawing #:



INDOOR SPEINDOOR SPECIFICATIONCIFICATION

Indoor Air Flow (Turbo/H/M/L/Si) (CFM)	600.4 / 559.2 / 500.3 / 441.4 / N/A	
Indoor Noise Level (Turbo/H/M/L/Si) (dBA)	N/A/40.5/39/38/35	
Indoor static pressure range (in.w.g.)	0-0.4	
Dimension (W×D×H)	inch	34.65 x 26.54 x 8.27
	mm	880.0×674.0×210.0
Package (W×D×H)	inch	42.13 x 28.54 x 11.02
	mm	1070×725×280
Net/Gross Weight	lbs	54.45/66.14
	kg	24.7/30

OUTDOOR SPECIFICATION

Compressor Type	ROTARY	
Compressor Model	KSN140D58UFZ	
Refrigerant	R454B	
Refrigerant Oil Charge(mL)	440	
Refrigerant Oil	7.2	
Outdoor Air Flow (Max) (CFM)	1765.8	
Outdoor Noise Level (dBA)	59.0	
Dimension (W×D×H)	inch	35.04 x 13.46 x 26.50
	mm	890.0×342.0×673.0
Package (W×D×H)	inch	39.17 x 15.67 x 29.13
	mm	995×398×740
Net/Gross Weight	lbs	92.59/100.31
	kg	42.0/45.5

EFFICIENCY

Cooling		Heating	
SEER2	20.0	HSPF2-4	10.5
EER2	12.5	COP	3.47

PERFORMANCE of Cooling

Cooling (Btu/hr)	
Rated Capacity	17000
Min/Max Capacity	7000~19000
Moisture Removal(L/h)	1.46
Standard Operating Range(°F/°C)	-13~122(-25~50)
Conditions:	Indoor: 80°F DB/67°F WB Outdoor: 95°F DB/75°F WB

PERFORMANCE of Heating

Heating (Btu/hr)	
1. @ 47°F Rated	20000
1. @ 47°F Min/Max Capacity	5500~22000
2. @ 17°F Rated	14000
3. @ 5°F Rated: Capacity / COP	14000/2.20
3. @ 5°F Max: Capacity	14000
Standard Operating Range(°F/°C)	-13~75(-25~24)
1. Conditions:	Indoor: 70°F DB/60°F WB Outdoor: 47°F DB/43°F WB
2. Conditions:	Indoor: 70°F DB/60°F WB Outdoor: 17°F DB/15°F WB
3. Conditions:	Indoor: 70°F DB/60°F WB Outdoor: 5°F DB/5°F WB

ELECTRICAL

Power Supply	208/230V,60Hz,1Ph	
System MCA	18.00	
Connection Wiring	14#x4	
System MOCP	20	
Compressor RLA	10.0	
Outdoor Fan Motor RLA	0.9	
Outdoor Fan Motor W	80	
Indoor Fan Motor RLA	1.2	
Indoor Fan Motor W	165	
System Power Input @ Cooling (W)	1445(600 ~ 1750)	
System Power Input @ Heating (W)	1690(330 ~1850)	
MCA: Min. circuit amps (A)	MOCP: Max. over current protection (A)	
RLA: Rated load amps (A)	W: Fan motor rated output (W)	

PIPING

Throttle type(Indoor)	N/A	
Throttle type(Outdoor)	EXV+Throttle valve	
Liquid Size	6.35mm(1/4in)	
Gas Size	12.7mm(1/2in)	
Max. Piping Length(ft/m)	98.40(30)	
Max. Height Difference(ft/m)	65.60(20)	
Max. Pre-charged Length(ft/m)	24.6(7.5)	
Refrigerant Pre-charged Amount(oz/kg)	47.97(1.36)	
Additional Charge of Refrigerant(oz/ft)/(g/m)	0.16(15)	
Connection Method	Flared	

Indoor Unit Dimension

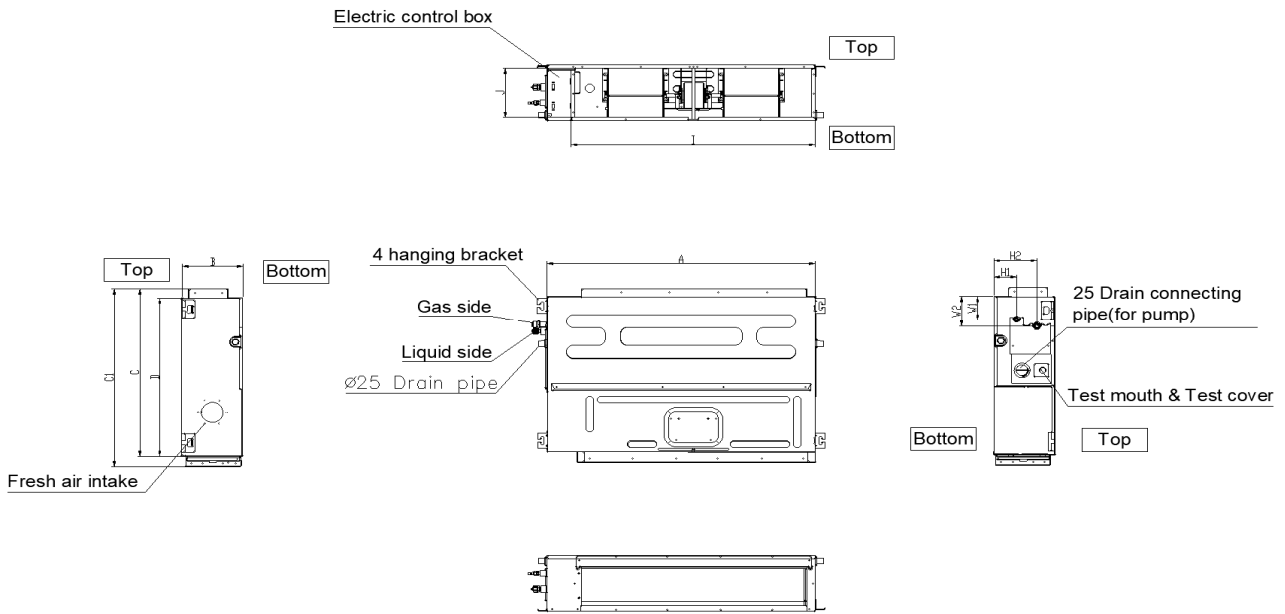

Model(kBtu/h)	unit	A	B	C	C1	D
	6 -12	mm	700	200	470	506
in		27-1/2	7-7/8	18-1/2	20	17-3/4
18	mm	880	210	634	674	600
	in	34-5/8	8-1/4	25	26-1/2	23-5/8

Installation Instruction

Installation place

The distance between the mounted indoor unit should meet the specifications illustrated in the following diagram.

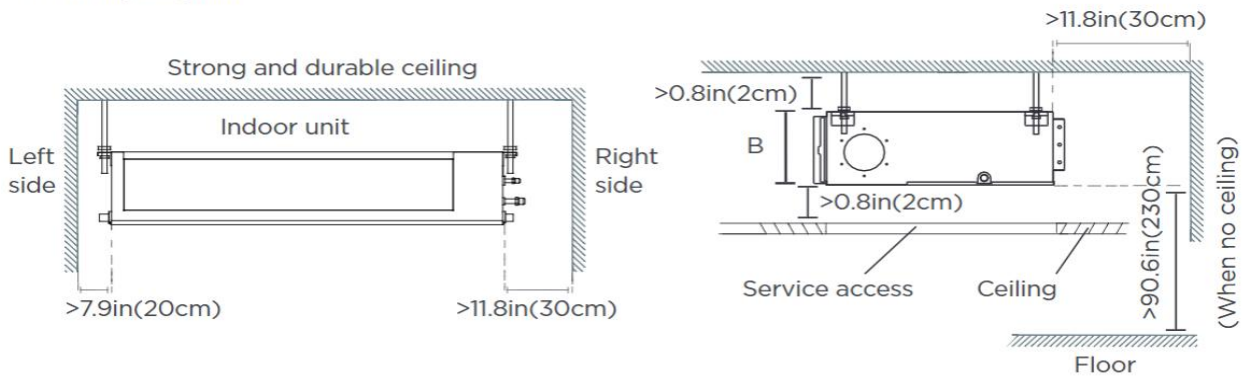

Outdoor Unit Dimension

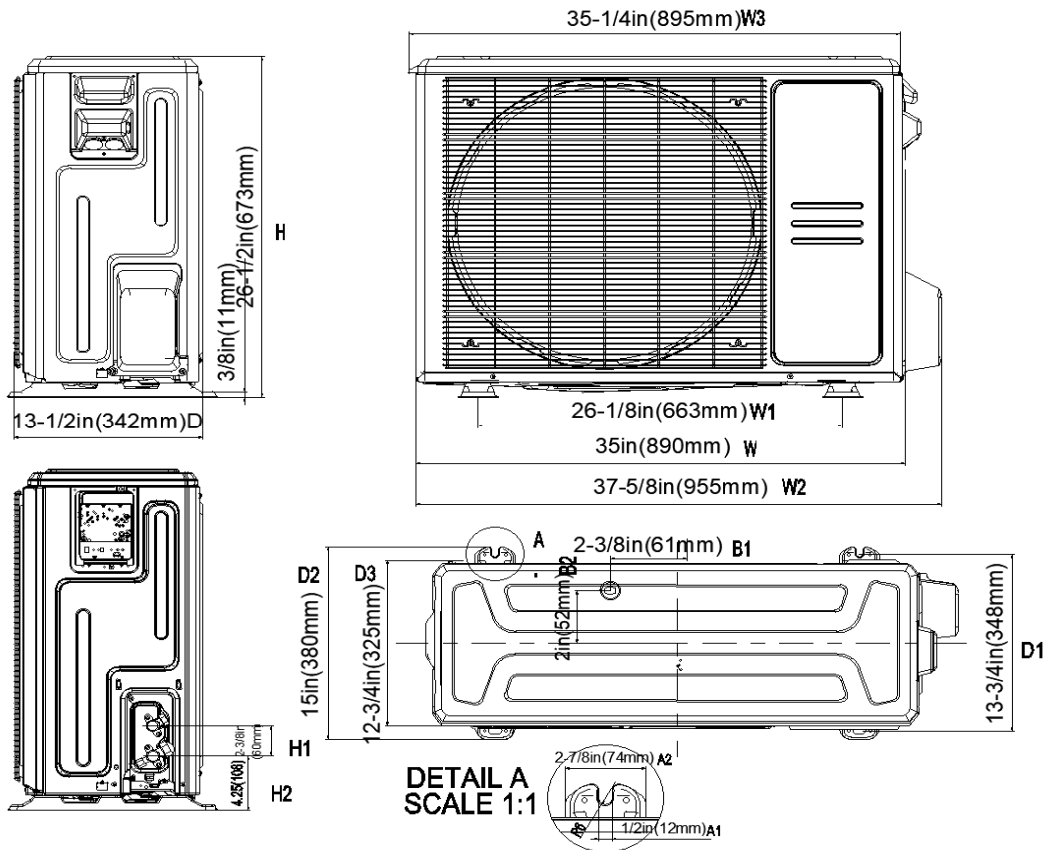

Installation Instruction

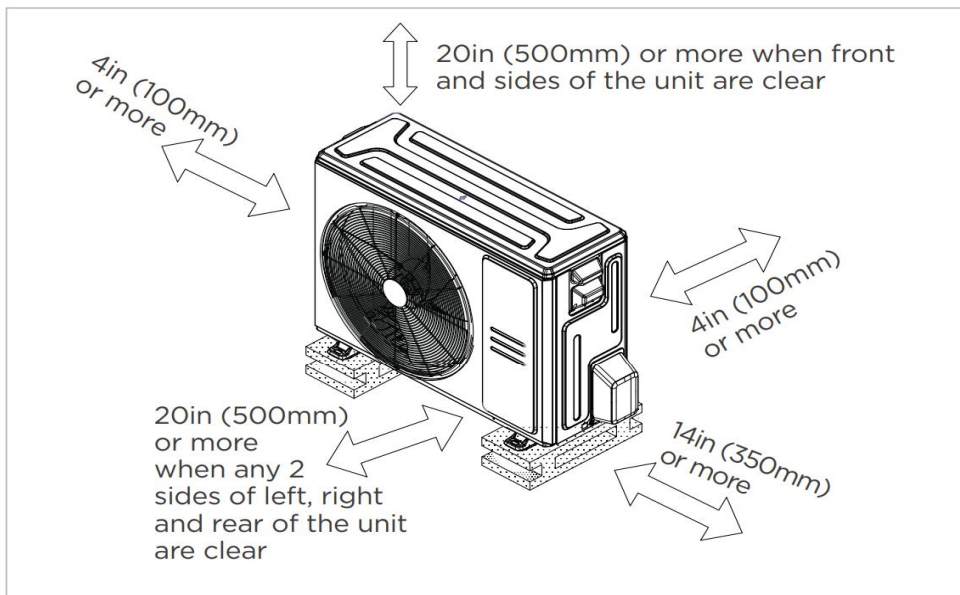

Meets all spatial requirements shown in Installation Clearance Requirements above.

Fan performance

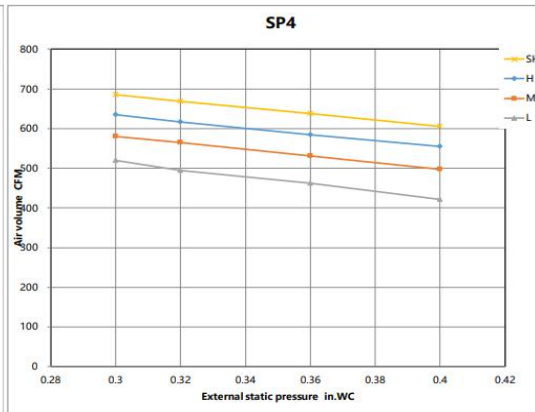
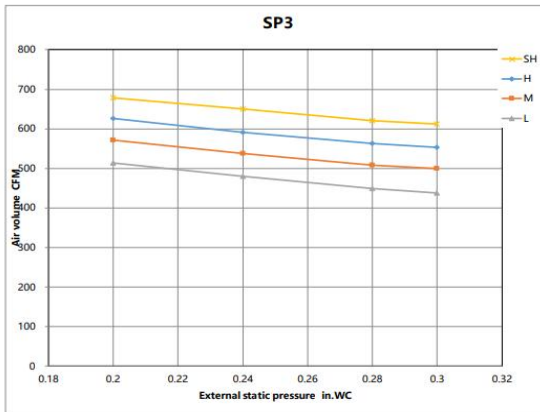
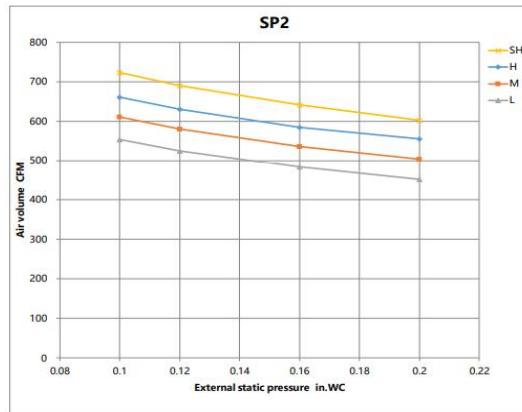
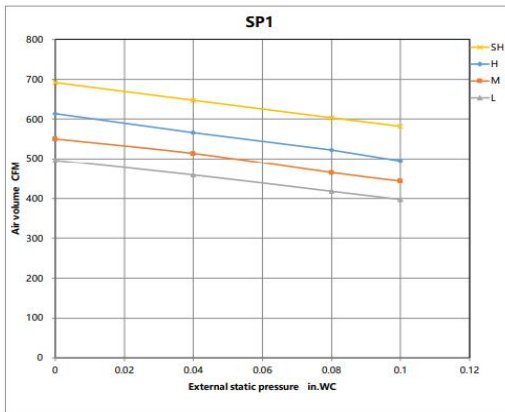

Constant airflow

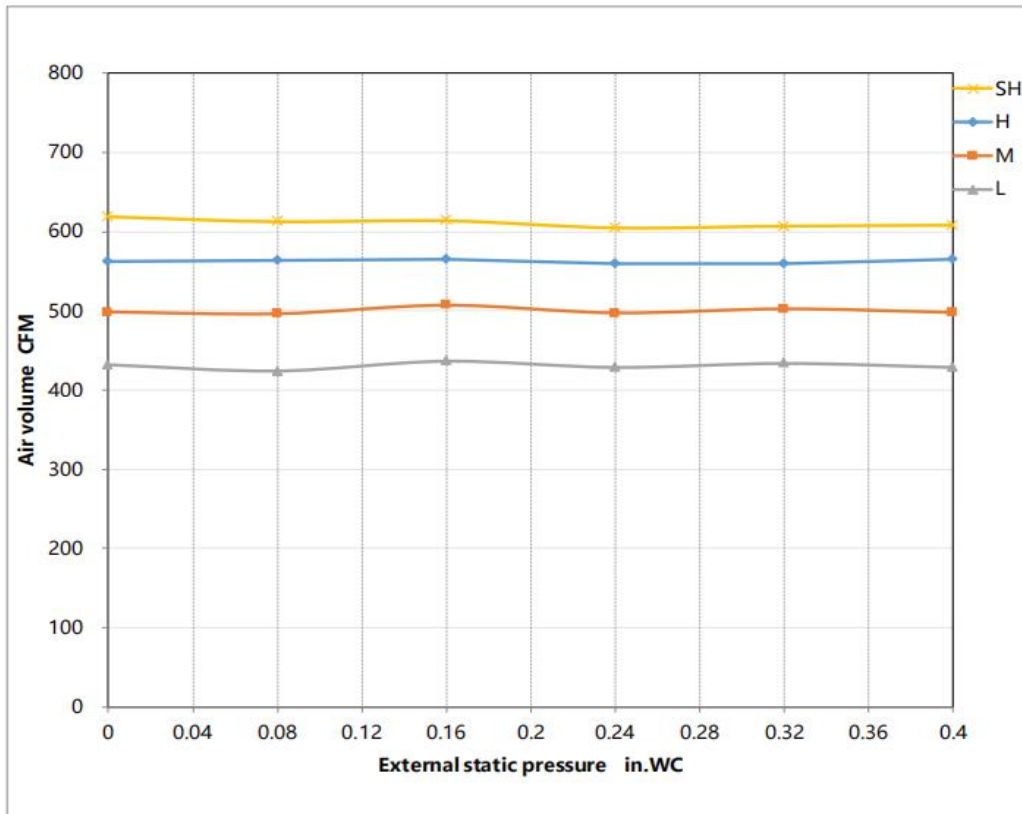

FEATURES

- Compatible with both horizontal and vertical installation(Optional)
- Static pressure setting stages: 4
- Refrigerant leakage detection sensor
- Constant airflow
- Built-in pump
- i-clean
- Fan speed stages: 1~100%
- WiFi capability: through WiFi dongle or wired controller with built-in WiFi
- OTA(by using wired controller AWC-8P-LC-WIFI)
- 2-pin connector(HA/HB) for programmable wired controller
- Multiple control options available:
 - Two way communication wired controller with built-in WiFi:AWC-8P-LC-WIFI
 - Infrared wired controller: AWC-4
 - Wireless remote controller
 - Third-Party 24V Thermostat

*24V interface is required.