

Slim Duct Regular System

Location:	Approval:
Engineer:	Date:
Submitted to:	Construction:
Submitted by:	Unit #:
Reference:	Drawing #:



INDOOR SPEINDOOR SPECIFICATIONCIFICATION

Indoor Air Flow (Turbo/H/M/L/Si) (CFM)	2001.2 / 1706.9 / 1412.6 / 1118.3 / N/A	
Indoor Noise Level (Turbo/H/M/L/Si) (dBA)	N/A/52/48/43/42	
Indoor static pressure range(in.w.g.)	0-0.8	
Dimension (W×D×H)	inch	55.12 x 31.50 x 14.96
	mm	1400.0×800.0×380.0
Package (W×D×H)	inch	62.99 x 36.02 x 17.52
	mm	1600×915×445
Net/Gross Weight	lbs	161.38/178.13
	kg	73.2/80.8

OUTDOOR SPECIFICATION

Compressor Type	ROTARY	
Compressor Model	KTQ420D1UMU	
Refrigerant	R454B	
Refrigerant Oil Charge(mL)	1400	
Refrigerant Oil	7.0	
Outdoor Air Flow (Max) (CFM)	4237.9	
Outdoor Noise Level (dBA)	64.0	
Dimension (W×D×H)	inch	37.48 x 16.34 x 52.48
	mm	952.0×415.0×1333.0
Package (W×D×H)	inch	43.11 x 19.49 x 58.27
	mm	1095×495×1480
Net/Gross Weight	lbs	209.44/240.08
	kg	95/108.9

EFFICIENCY

Cooling		Heating	
SEER2	17.0	HSPF2-4	9.7
EER2	10.0	COP	3.70

PERFORMANCE of Cooling

Cooling (Btu/hr)	
Rated Capacity	58000
Min/Max Capacity	14600~63000
Moisture Removal(L/h)	5.24
Standard Operating Range(°F/°C)	-13~122(-25~50)
Conditions:	Indoor: 80°F DB/67°F WB Outdoor: 95°F DB/75°F WB

PERFORMANCE of Heating

Heating (Btu/hr)	
1. @ 47°F Rated	60000
1. @ 47°F Min/Max Capacity	11800~67000
2. @ 17°F Rated	40000
3. @ 5°F Rated: Capacity / COP	40000/2.20
3. @ 5°F Max: Capacity	40000
Standard Operating Range(°F/°C)	-13~75(-25~24)
1. Conditions:	Indoor: 70°F DB/60°F WB Outdoor: 47°F DB/43°F WB
2. Conditions:	Indoor: 70°F DB/60°F WB Outdoor: 17°F DB/15°F WB
3. Conditions:	Indoor: 70°F DB/60°F WB Outdoor: 5°F DB/5°F WB

ELECTRICAL

Power Supply	208/230V,60Hz,1Ph	
System MCA	42.00	
Connection Wiring	14#x3	
System MOCP	45	
Compressor RLA	25.0	
Outdoor Fan Motor RLA	2.2	
Outdoor Fan Motor W	85	
Indoor Fan Motor RLA	4.0	
Indoor Fan Motor W	560	
System Power Input @ Cooling (W)	5800(1200 ~ 6780)	
System Power Input @ Heating (W)	4750(775 ~5170)	
MCA: Min. circuit amps (A)	MOCP: Max. over current protection (A)	
RLA: Rated load amps (A)	W: Fan motor rated output (W)	

PIPING

Throttle type(Indoor)	N/A	
Throttle type(Outdoor)	EXV+Throttle valve	
Liquid Size	9.52mm(3/8in)	
Gas Size	19mm(3/4in)	
Max. Piping Length(ft/m)	246.00(75)	
Max. Height Difference(ft/m)	98.40(30)	
Max. Pre-charged Length(ft/m)	24.6(7.5)	
Refrigerant Pre-charged Amount(oz/kg)	144.62(4.10)	
Additional Charge of Refrigerant(oz/ft)/(g/m)	0.32(30)	
Connection Method	Flared	

Indoor Unit Dimension

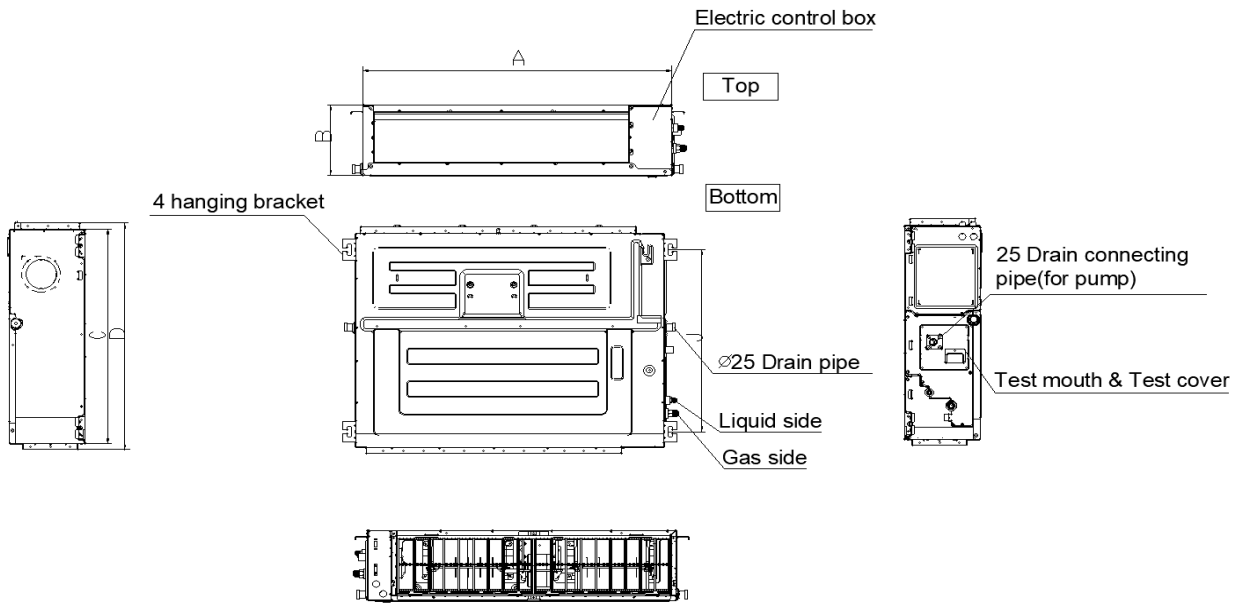

MODEL	A	B	C	D
9K	27-1/2in(700mm)	7-7/8in(200mm)	17-3/4(450mm)	20in(506mm)
12K	27-1/2in(700mm)	9-5/8in(245mm)	29-1/2(750mm)	31-1/4in(795mm)
18K~24K	39-3/8in(1000mm)	9-5/8in(245mm)	29-1/2(750mm)	31-1/4in(795mm)
36K~48K	47-1/8in(1200mm)	11-7/8in(300mm)	29-1/2(750mm)	31-1/4in(795mm)
60K	55-1/8in(1400mm)	15in(380mm)	31-1/2in(800mm)	33-1/4in(845mm)

Installation Instruction

Installation place

The distance between the mounted indoor unit should meet the specifications illustrated in the following diagram.

1) Ceiling-mounted

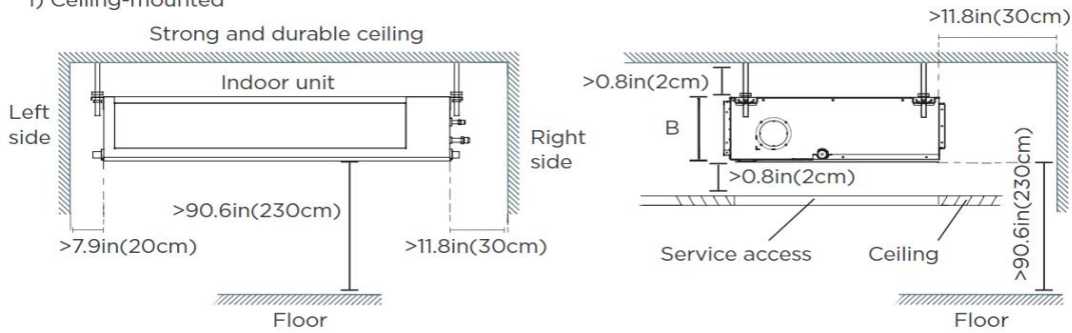

2) Wall-mounted

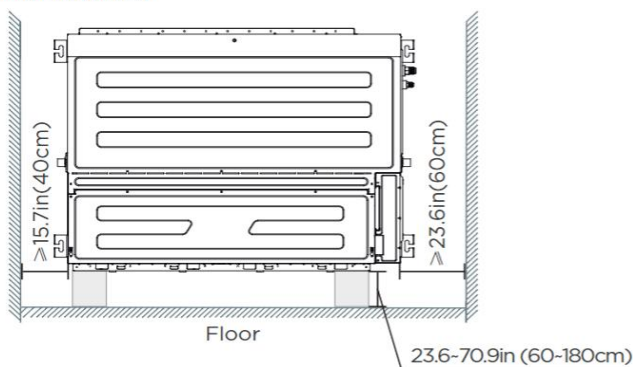

Outdoor Unit Dimension

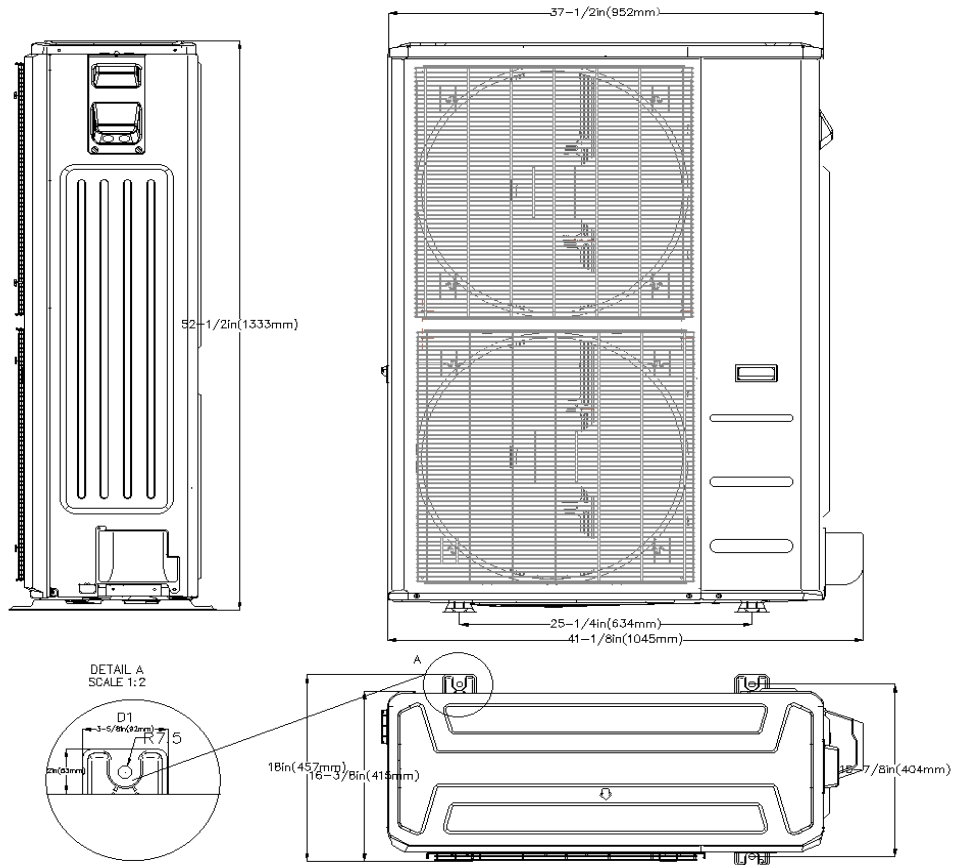

Installation Instruction

REQUIRED CLEARANCE

*1 20in. (500mm) or more when front and sides of the unit are clear

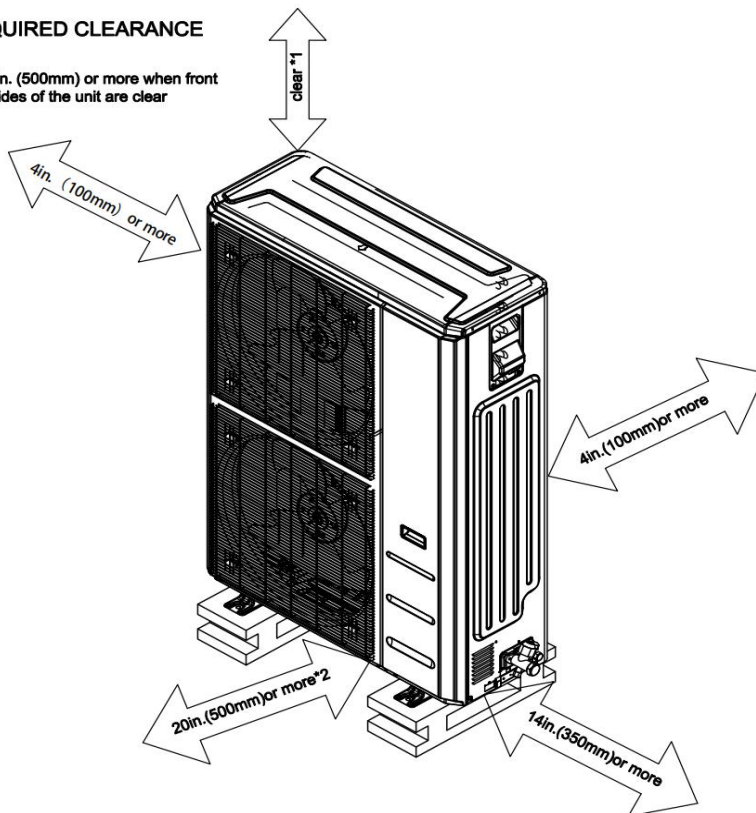

*2 When any 2 sides of left, right and rear of the unit are clear

Fan performance

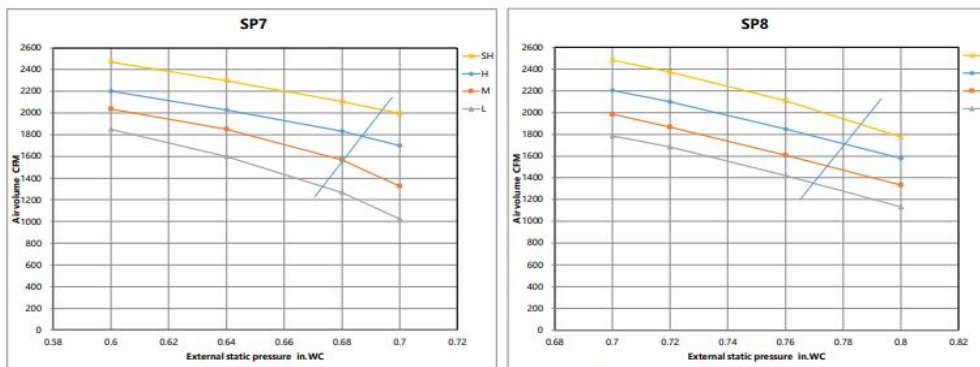
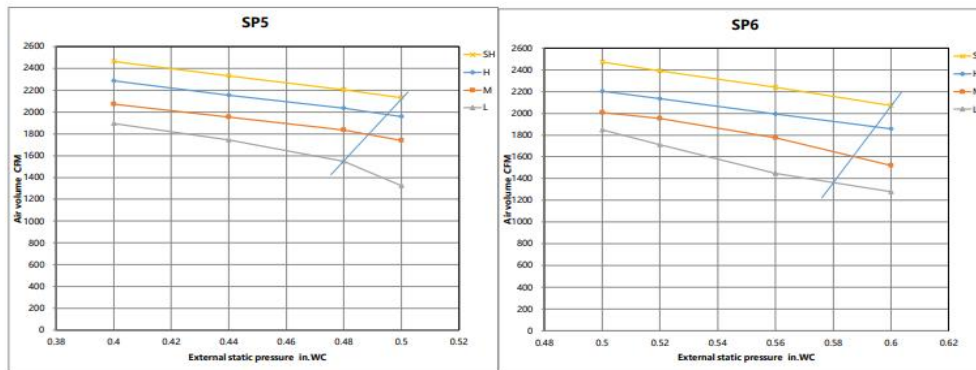
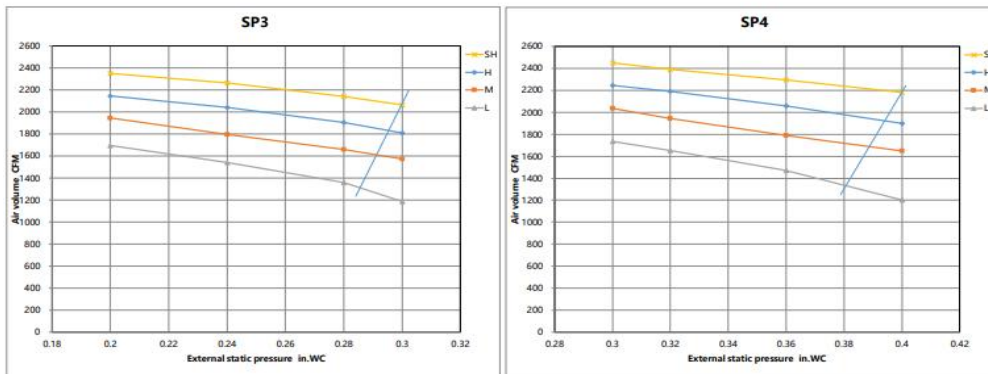
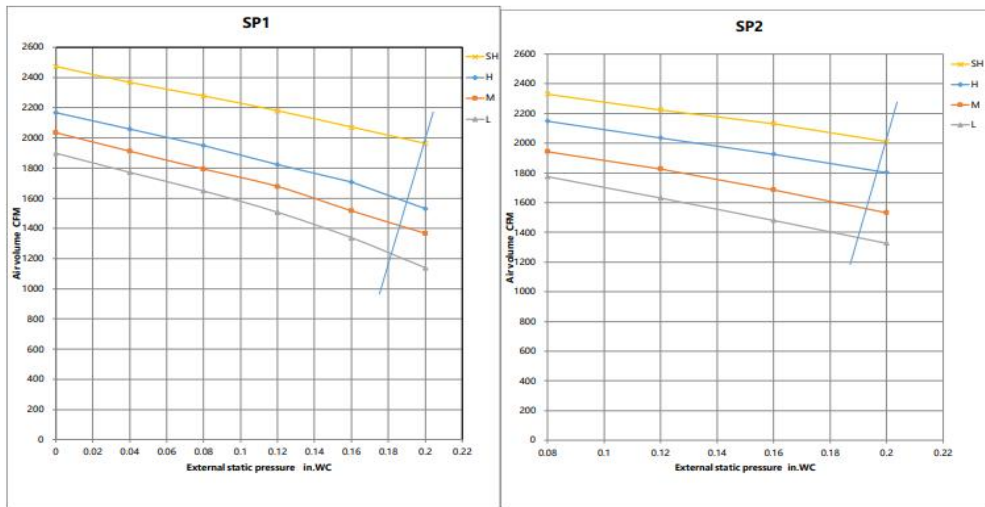

Constant air volume

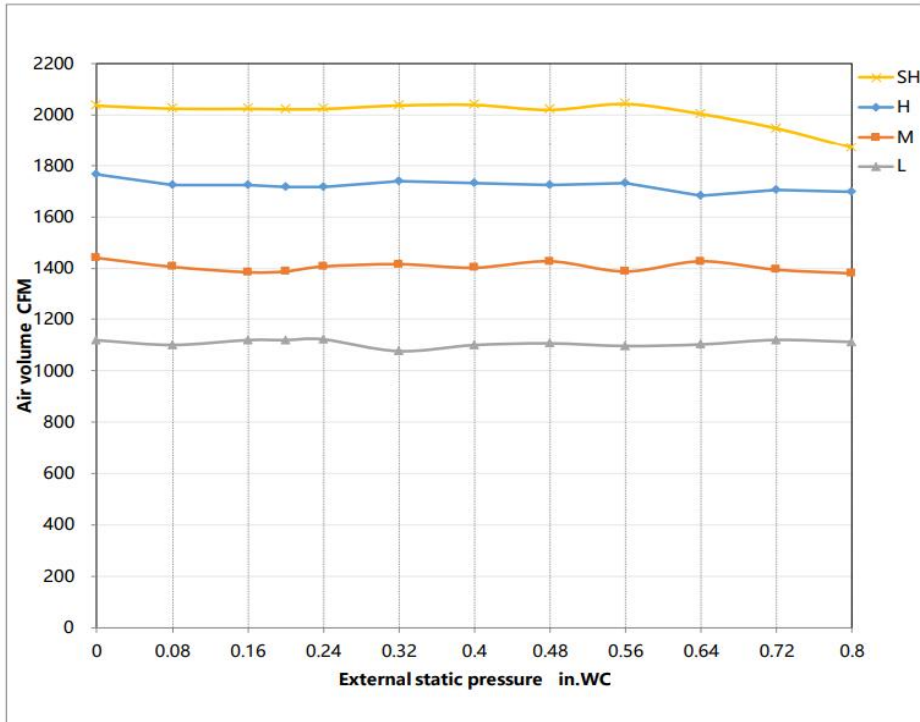

FEATURES

- Compatible with both horizontal and vertical installation
- Static pressure up to 0.8 in.w.g(for all models)
- Static pressure setting stages: 8
- Refrigerant leakage detection sensor
- Constant airflow
- Built-in pump
- i-clean
- Fan speed stages: 1~100%
- WiFi capability: through wired controller with built-in WiFi
- OTA(by using wired controller AWC-8P-LC-WIFI)
- 2-pin connector(HA/HB) for programmable wired controller
- Multiple control options available:
 - Two way communication wired controller with built-in WiFi:AWC-8P-LC-WIFI
 - Infrared wired controller: AWC-4
 - Wireless remote controller
 - Third-Party 24V Thermostat

*24V interface is required.