

## High Wall Heat Pump System

Location:	Approval:
Engineer:	Date:
Submitted to:	Construction:
Submitted by:	Unit #:
Reference:	Drawing #:



### INDOOR SPECIFICATION

Indoor Air Flow (Turbo/H/M/L/Si) (CFM)	370.8 / 306.1 / 235.4 / 188.4 / 141.3	
Indoor Noise Level (Turbo/H/M/L/Si) (dBA)	44.0/40.5/35.0/26.5/17.5	
Dimension (W×D×H)	inch	31.57 x 7.87 x 11.61
	mm	802.0×200.0×295.0
Package (W×D×H)	inch	34.45 x 11.22 x 14.96
	mm	875×285×380
Net/Gross Weight	lbs	19.84/26.01
	kg	9.0/11.8

### OUTDOOR SPECIFICATION

Compressor Type	ROTARY	
Compressor Model	KSK103D33UEZ3	
Refrigerant	R454B	
Refrigerant Oil Charge(mL)	310	
Refrigerant Oil	VG74	
Outdoor Air Flow (Max) (CFM)	1235.3	
Outdoor Noise Level (dBA)	53.0	
Dimension (W×D×H)	inch	30.12 x 11.93 x 21.85
	mm	765.0×303.0×555.0
Package (W×D×H)	inch	34.92 x 13.27 x 24.02
	mm	887×337×610
Net/Gross Weight	lbs	64.59/70.11
	kg	29.3/31.8

### EFFICIENCY

Cooling		Heating	
SEER2	24.5	HSPF2-4	10.7
EER2	15.0	COP	4.20

### PERFORMANCE of Cooling

Cooling (Btu/hr)	
Rated Capacity	9000
Min/Max Capacity	2600~13000
Moisture Removal(L/h)	0.8
Standard Operating Range(°F/°C)	-13~122(-25~50)
Conditions:	Indoor: 80°F DB/67°F WB Outdoor: 95°F DB/75°F WB

### PERFORMANCE of Heating

Heating (Btu/hr)	
1. @ 47°F Rated	10000
1. @ 47°F Min/Max Capacity	4500~12800
2. @ 17°F Rated	8800
3. @ 5°F Rated: Capacity / COP	7300/2.20
3. @ 5°F Max: Capacity	7300
Standard Operating Range(°F/°C)	-13~75(-25~24)
1. Conditions:	Indoor: 70°F DB/60°F WB Outdoor: 47°F DB/43°F WB
2. Conditions:	Indoor: 70°F DB/60°F WB Outdoor: 17°F DB/15°F WB
3. Conditions:	Indoor: 70°F DB/60°F WB Outdoor: 5°F DB/5°F WB

### ELECTRICAL

Power Supply	115V,60Hz,1Ph
System MCA	18.0
Connection Wiring	14#x4
System MOCP	20
Compressor RLA	14.0
Outdoor Fan Motor RLA	0.6
Outdoor Fan Motor W	34
Indoor Fan Motor RLA	0.6
Indoor Fan Motor W	20
System Power Input @ Cooling (W)	600(180 ~ 1080)
System Power Input @ Heating (W)	698(280 ~980)
MCA: Min. circuit amps (A)	MOCP: Max. over current protection (A)
RLA: Rated load amps (A)	W: Fan motor rated output (W)

### PIPING

Throttle type(Indoor)	N/A
Throttle type(Outdoor)	EXV
Liquid Size	6.35mm(1/4in)
Gas Size	9.52mm(3/8in)
Max. Piping Length(ft/m)	82.00(25)
Max. Height Difference(ft/m)	49.20(15)
Max. Pre-charged Length(ft/m)	24.6(7.5)
Refrigerant Pre-charged Amount(oz/g)	33.51(0.95)
Additional Charge of Refrigerant((oz/ft)/(g/m))	0.16(15)
Connection Method	Flared

### Indoor Unit Dimension

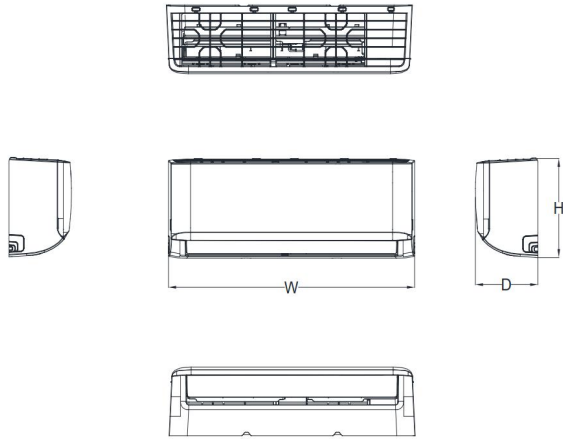

Capacity	Body Code	W(inch/mm)	D(mm/inch)	H(mm/inch)
6K~9K	A	28-3/4in /729mm	7-7/8in /200mm	11-1/2in /292mm
9K~12K	B	31-5/8in /802mm	7-7/8in /200mm	11-5/8in /295mm
18K	C	38-1/4in /971mm	9in/228mm	12-5/8in /321mm
18K~24K	D	42-5/8in /1082mm	9-1/4in/234mm	13-1/4in /337mm
30K~36K	F	49-5/8in /1259mm	11-1/8in/283mm	14-1/4in /362mm

### Installation Instruction

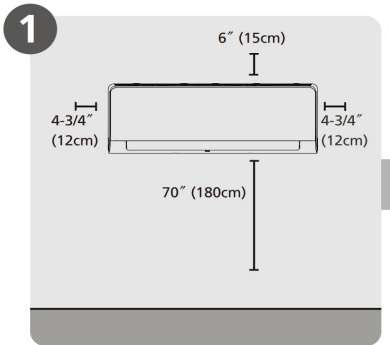

Select Installation Location

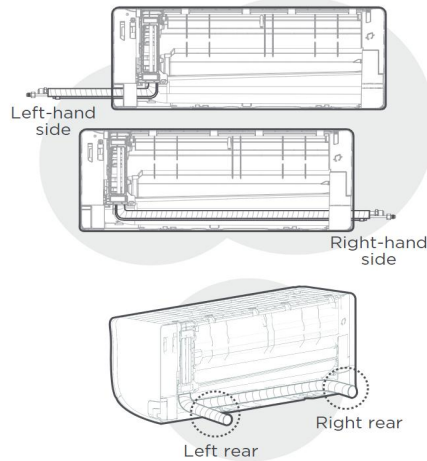

NOTE:  
Based on the position of the wall hole relative to the mounting plate, choose the side from which the piping will exit the unit. You have four options for the exit direction of the piping.

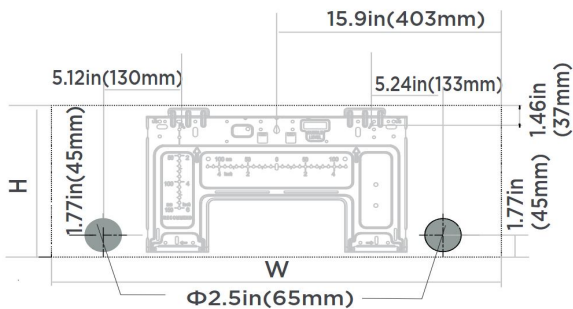

Indoor unit dimensions(WxH):  
31.7in(806mm)x11.65in(296mm)

NOTE:  
When the gas side connective pipe isΦ (5/8in)16mm or more, the wall hole should be (3-1/2in)90mm.

## Outdoor Unit Dimension

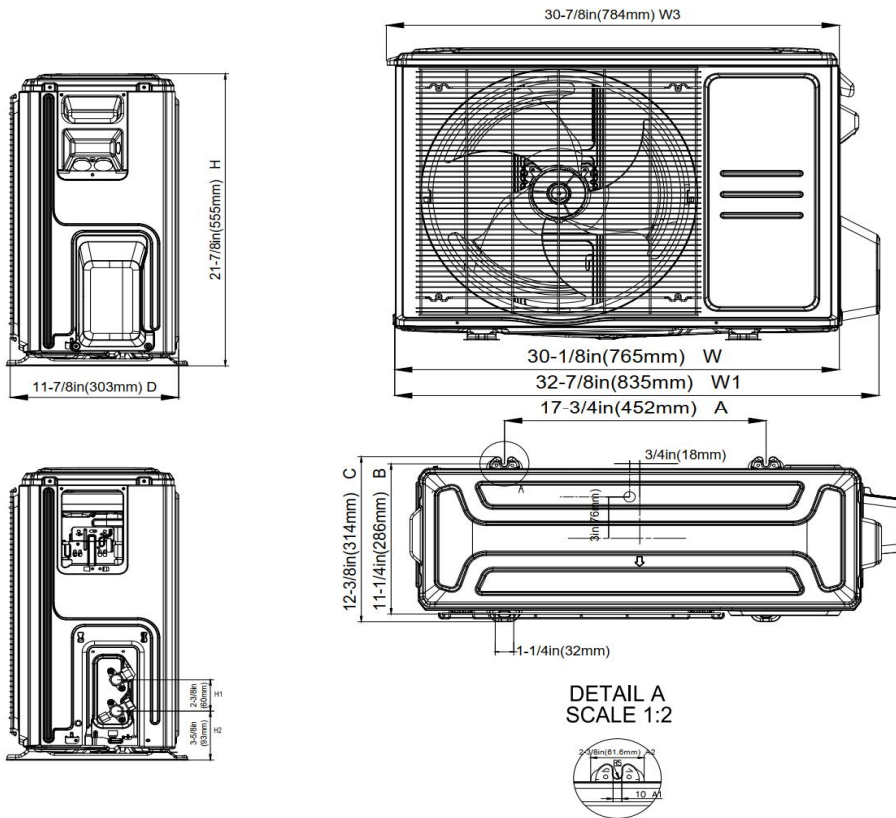

## Installation Instruction

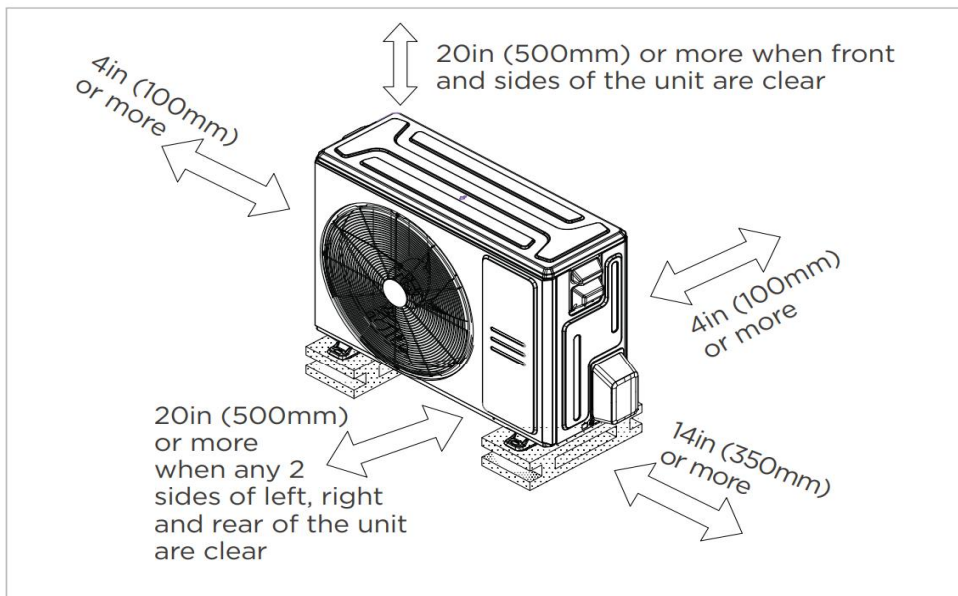

Meets all spatial requirements shown in Installation Clearance Requirements above.

## FEATURES

- Indoor unit TU1 copper coil
- Humidity control
- 1~100% fan speed setting
- WiFi capability: through WiFi dongle or wired controller with built-in WiFi
- OTA(by using WiFi dongle)
- Multiple control options available:
  - Two way communication wired controller:AWC-8P-CPP\*
  - Two way communication wired controller with built-in WiFi:AWC-8P-LC-WIFI
  - Infrared wired controller: AWC-4
  - Wireless remote controller
  - Third-Party 24V Thermostat

\*24V interface is required.