

Multi Zone Heat Pump System

Location:	Approval:
Engineer:	Date:
Submitted to:	Construction:
Submitted by:	Unit #:
Reference:	Drawing #:



OUTDOOR SPECIFICATION

Compressor Type	ROTARY	
Compressor Model	KTM240D46UKT2	
Refrigerant	R454B	
Refrigerant Oil Charge(mL)	620	
Refrigerant Oil	VG74	
Outdoor Air Flow (Max) (CFM)	2131	
Outdoor Noise Level (dBA)	62	
Dimension (W×D×H)	inch	37.24 x 16.14 x 31.89
	mm	946×410×810
Package (W×D×H)	inch	42.91 x 19.68 x 34.84
	mm	1090×500×885
Net/Gross Weight	lbs	137.35/148.15
	kg	62.3/67.2

ELECTRICAL

Power Supply	208/230V,60Hz,1Ph
System MCA	17.5
Connection Wiring	AWG 14-4
System MOCP	20
Compressor RLA	9.2
Outdoor Fan Motor RLA	1.2
Outdoor Fan Motor W	120
Indoor Fan Motor RLA	/
Indoor Fan Motor W	/
System Power Input @ Cooling (W)	1460/(400 ~ 2300)
System Power Input @ Heating (W)	1503/(350 ~ 2300)
MCA: Min. circuit amps (A)	MOCP: Max. over current protection (A)
RLA: Rated load amps (A)	W: Fan motor rated output (W)

EFFICIENCY

Cooling		Heating	
SEER2	21.0	HSPF2-4	10.0
EER2	13	COP	3.9

PERFORMANCE of Cooling

Cooling (Btu/hr)	
Rated Capacity	19000
Min/Max Capacity	5400~27600
Moisture Removal(L/h)	1.4
Standard Operating Range(°F/°C)	-22~122/(-30~50)
Rated Cooling Conditions: Indoor: 80°F DB/67°F WB Outdoor: 95°F DB/75°F WB	

PERFORMANCE of Heating

Heating (Btu/hr)	
1. @ 47°F Rated	20000
1. @ 47°F Min/Max Capacity	5700~25400
2. @ 17°F Rated(H32)	16400
3. @ 5°F Rated: Capacity / COP(H42)	18000/2
3. @ 5°F Max: Capacity	18000
Standard Operating Range(°F/°C)	-22~75/(-30~24)
1. Conditions: Indoor: 70°F DB/60°F WB Outdoor: 47°F DB/43°F WB	
2. Conditions: Indoor: 70°F DB/60°F WB Outdoor: 17°F DB/15°F WB	
3. Conditions: Indoor: 70°F DB/60°F WB Outdoor: 5°F DB/5°F WB	

PIPING

Liquid Size	3x6.35mm(3x1/4in)
Gas Size	3x9.52mm(3x3/8in)
Max. Piping Length for all rooms(ft/m)	196.8/(60)
Max. Piping Length for one IDU(ft/m)	98.4/(30)
Max. Height Difference of IDU and ODU(ft/m)	49.2/(15)
Refrigerant Pre-charged Amount(oz/kg)	78.31/(2.22)
Refrigerant Precharge Length(ft/m)	24.6(7.5)x3
Additional Charge of Refrigerant (Φ6.35 (1/4") liquid pipe) ((oz/ft)/(g/m))	0.16/(15)
Additional Charge of Refrigerant (Φ9.52 (3/8") liquid pipe) ((oz/ft)/(g/m))	0.32(30)
Connection Method	Flared

Outdoor Unit Dimension

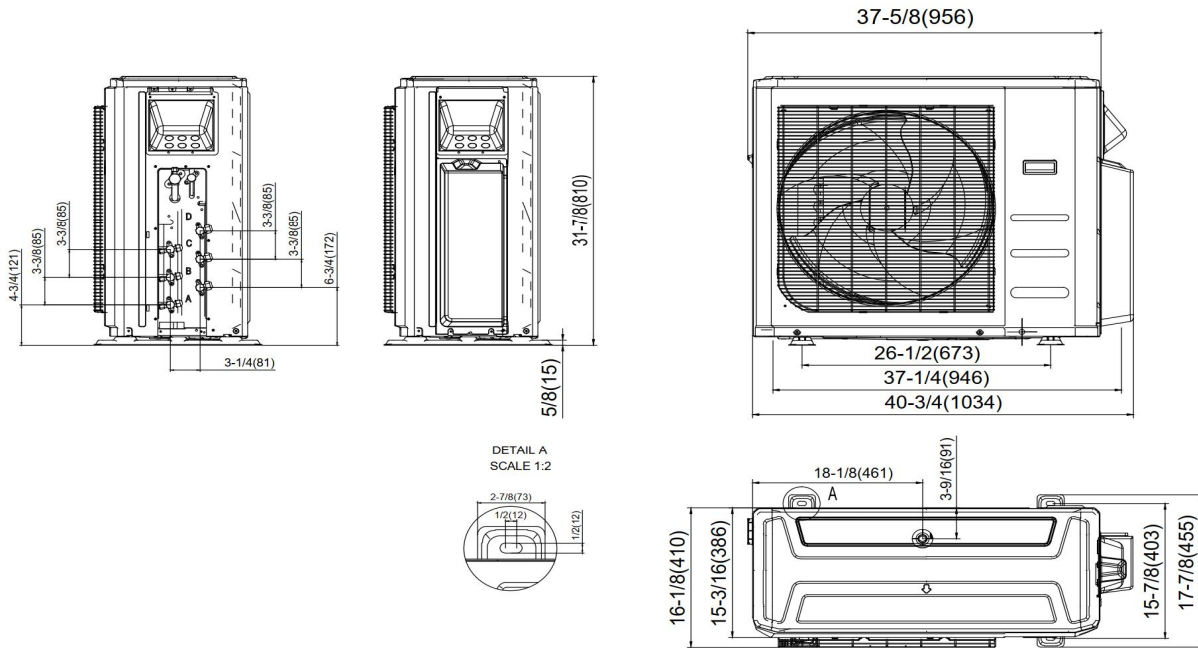

Installation Instruction

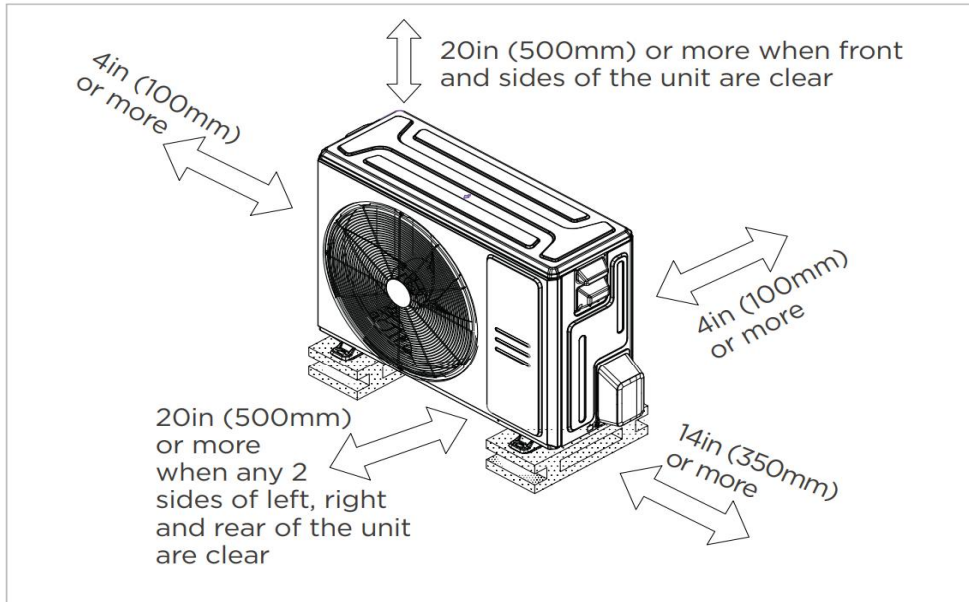

Meets all spatial requirements shown in Installation Clearance Requirements above.