

Multi Zone Heat Pump System

Location:	Approval:
Engineer:	Date:
Submitted to:	Construction:
Submitted by:	Unit #:
Reference:	Drawing #:



OUTDOOR SPECIFICATION

Compressor Type	ROTARY	
Compressor Model	KTF310D43UMT	
Refrigerant	R454B	
Refrigerant Oil Charge(mL)	1000	
Refrigerant Oil	VG74	
Outdoor Air Flow (Max) (CFM)	2148	
Outdoor Noise Level (dBA)	61	
Dimension (W×D×H)	inch	37.24 x 16.14 x 31.89
	mm	946×410×810
Package (W×D×H)	inch	42.91 x 19.68 x 34.84
	mm	1090×500×885
Net/Gross Weight	lbs	168.43/179.67
	kg	76.4/81.5

ELECTRICAL

Power Supply	208/230V,60Hz,1Ph
System MCA	30
Connection Wiring	AWG 14-4
System MOCP	35
Compressor RLA	17
Outdoor Fan Motor RLA	1.3
Outdoor Fan Motor W	120
Indoor Fan Motor RLA	/
Indoor Fan Motor W	/
System Power Input @ Cooling (W)	2250/(500 ~ 3570)
System Power Input @ Heating (W)	2198/(500 ~ 3440)
MCA: Min. circuit amps (A)	MOCP: Max. over current protection (A)
RLA: Rated load amps (A)	W: Fan motor rated output (W)

EFFICIENCY

Cooling		Heating	
SEER2	21.0	HSPF2-4	10.0
EER2	12	COP	3.6

PERFORMANCE of Cooling

Cooling (Btu/hr)	
Rated Capacity	27000
Min/Max Capacity	7200~33000
Moisture Removal(L/h)	0.7
Standard Operating Range(°F/°C)	-22~122/(-30~50)
Rated Cooling Conditions:	Indoor: 80°F DB/67°F WB Outdoor: 95°F DB/75°F WB

PERFORMANCE of Heating

Heating (Btu/hr)	
1. @ 47°F Rated	27000
1. @ 47°F Min/Max Capacity	8400~32000
2. @ 17°F Rated(H32)	23600
3. @ 5°F Rated: Capacity / COP(H42)	27000/1.9
3. @ 5°F Max: Capacity	27000
Standard Operating Range(°F/°C)	-22~75/(-30~24)
1. Conditions:	Indoor: 70°F DB/60°F WB Outdoor: 47°F DB/43°F WB
2. Conditions:	Indoor: 70°F DB/60°F WB Outdoor: 17°F DB/15°F WB
3. Conditions:	Indoor: 70°F DB/60°F WB Outdoor: 5°F DB/5°F WB

PIPING

Liquid Size	4x6.35mm(4x1/4in)
Gas Size	3x9.52mm+1x12.7mm
Max. Piping Length for all rooms(ft/m)	262.4/(80)
Max. Piping Length for one IDU(ft/m)	114.8/(35)
Max. Height Difference of IDU and ODU(ft/m)	49.2/(15)
Refrigerant Pre-charged Amount(oz/kg)	120.63/(3.42)
Refrigerant Precharge Length(ft/m)	24.6(7.5)x4
Additional Charge of Refrigerant (Φ6.35 (1/4") liquid pipe) ((oz/ft)/(g/m))	0.16/(15)
Additional Charge of Refrigerant (Φ9.52 (3/8") liquid pipe) ((oz/ft)/(g/m))	0.32(30)
Connection Method	Flared

Outdoor Unit Dimension

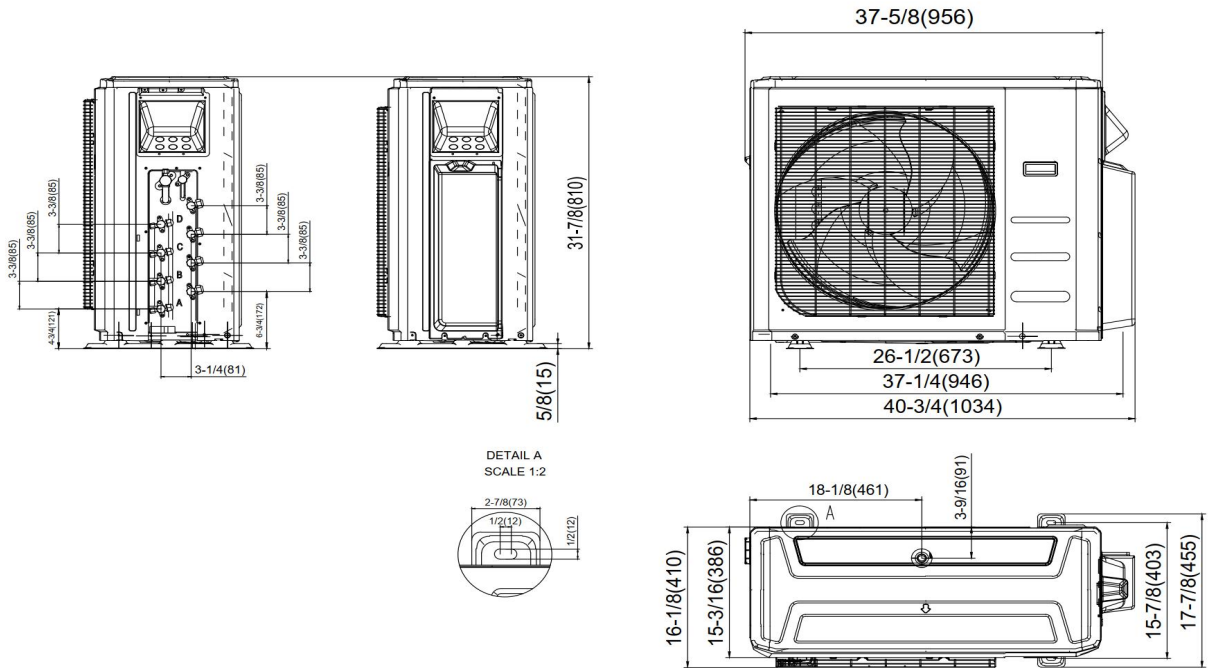

Installation Instruction

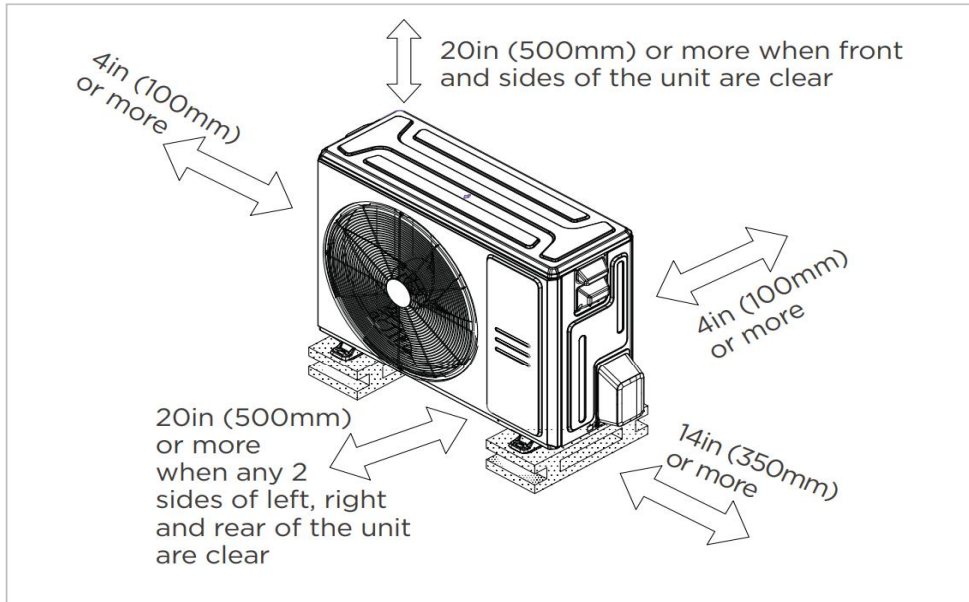

Meets all spatial requirements shown in Installation Clearance Requirements above.