

Multi Zone Heat Pump System

Location:	Approval:
Engineer:	Date:
Submitted to:	Construction:
Submitted by:	Unit #:
Reference:	Drawing #:



OUTDOOR SPECIFICATION

Compressor Type	TWIN-ROTARY	
Compressor Model	ETPQ440D1UMUB	
Refrigerant	R454B	
Refrigerant Oil Charge(mL)	1300	
Refrigerant Oil	VG75	
Outdoor Air Flow (Max) (CFM)	4503	
Outdoor Noise Level (dBA)	65	
Dimension (W×D×H)	inch	37.48 x 16.34 x 52.48
	mm	952×415×1333
Package (W×D×H)	inch	43.11 x 19.49 x 58.27
	mm	1095×495×1480
Net/Gross Weight	lbs	246.47/276.68
	kg	111.8/125.5

ELECTRICAL

Power Supply	208/230V,60Hz,1Ph
System MCA	39.5
Connection Wiring	AWG 14-4
System MOCP	40
Compressor RLA	28
Outdoor Fan Motor RLA	2.5
Outdoor Fan Motor W	85
Indoor Fan Motor RLA	/
Indoor Fan Motor W	/
System Power Input @ Cooling (W)	4250/(1200 ~ 5600)
System Power Input @ Heating (W)	4741/(1200 ~ 5400)
MCA: Min. circuit amps (A)	MOCP: Max. over current protection (A)
RLA: Rated load amps (A)	W: Fan motor rated output (W)

EFFICIENCY

Cooling		Heating	
SEER2	21.4	HSPF2-4	10.6
EER2	12	COP	3.4

PERFORMANCE of Cooling

Cooling (Btu/hr)	
Rated Capacity	51000
Min/Max Capacity	19000~58000
Moisture Removal(L/h)	4
Standard Operating Range(°F/°C)	-22~122/(-30~50)
Rated Cooling Conditions:	Indoor: 80°F DB/67°F WB Outdoor: 95°F DB/75°F WB

PERFORMANCE of Heating

Heating (Btu/hr)	
1. @ 47°F Rated	55000
1. @ 47°F Min/Max Capacity	20000~56000
2. @ 17°F Rated(H32)	45000
3. @ 5°F Rated: Capacity / COP(H42)	48000/2
3. @ 5°F Max: Capacity	48000
Standard Operating Range(°F/°C)	-22~75/(-30~24)
1. Conditions:	Indoor: 70°F DB/60°F WB Outdoor: 47°F DB/43°F WB
2. Conditions:	Indoor: 70°F DB/60°F WB Outdoor: 17°F DB/15°F WB
3. Conditions	Indoor: 70°F DB/60°F WB Outdoor: 5°F DB/5°F WB

PIPING

Liquid Size	6x6.35mm(6x1/4in)
Gas Size	4x9.52mm+2x12.7mm
Max. Piping Length for all rooms(ft/m)	262.4/(80)
Max. Piping Length for one IDU(ft/m)	114.8/(35)
Max. Height Difference of IDU and ODU(ft/m)	49.2/(15)
Refrigerant Pre-charged Amount(oz/kg)	151.68/(4.3)
Refrigerant Precharge Length(ft/m)	24.6(7.5)x6
Additional Charge of Refrigerant (Φ6.35 (1/4") liquid pipe) ((oz/ft)/(g/m))	0.16/(15)
Additional Charge of Refrigerant (Φ9.52 (3/8") liquid pipe) ((oz/ft)/(g/m))	0.32(30)
Connection Method	Flared

### Outdoor Unit Dimension

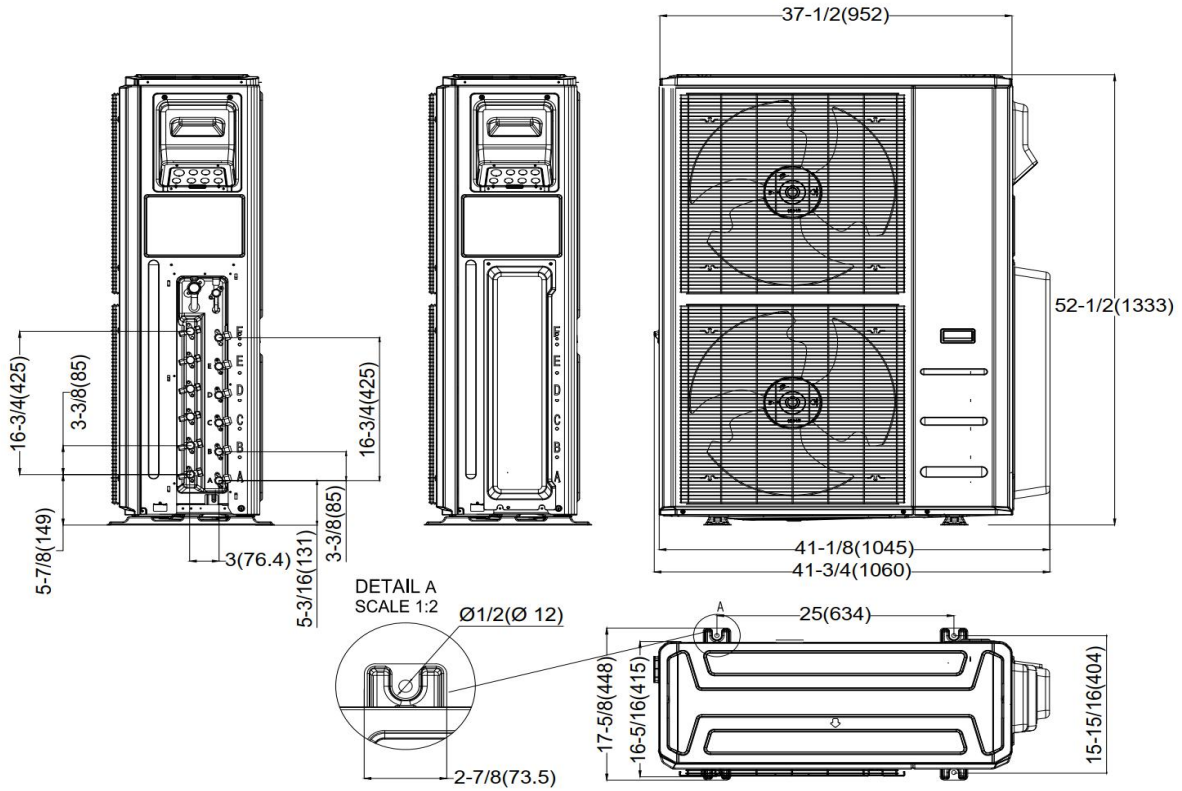

### Installation Instruction

