

**Ceiling&Floor Heat Pump System**

Location:	Approval:
Engineer:	Date:
Submitted to:	Construction:
Submitted by:	Unit #:
Reference:	Drawing #:



**INDOOR SPEINDOOR SPECIFICATIONCIFICATION**

<b>Indoor Air Flow (Turbo/H/M/L/Si) (CFM)</b>	1224.3 / 1088.9 / 988.8 / 765.2 / 653.3	
<b>Indoor Noise Level (Turbo/H/M/L/Si) (dBA)</b>	N/A/51.0/45.5/39.0/35.0	
<b>Dimension (W×D×H)</b>	inch	64.96 x 26.57 x 9.25
	mm	1650.0×675.0×235.0
<b>Package (W×D×H)</b>	inch	67.91 x 29.72 x 12.52
	mm	1725×755×318
<b>Net/Gross Weight</b>	lbs	88.85/104.94
	kg	40.3/47.6

**OUTDOOR SPECIFICATION**

<b>Compressor Type</b>	TWIN-ROTARY	
<b>Compressor Model</b>	EKPQ420D1UMUA	
<b>Refrigerant</b>	R454B	
<b>Refrigerant Oil Charge(mL)</b>	1460	
<b>Refrigerant Oil</b>	VG75	
<b>Outdoor Air Flow (Max) (CFM)</b>	3001.9	
<b>Outdoor Noise Level (dBA)</b>	65.0	
<b>Dimension (W×D×H)</b>	inch	38.58 x 16.34 x 38.39
	mm	980.0×415.0×975.0
<b>Package (W×D×H)</b>	inch	45.08 x 19.68 x 42.52
	mm	1145×500×1080
<b>Net/Gross Weight</b>	lbs	206.57/237.44
	kg	93.7/107.7

**EFFICIENCY**

Cooling		Heating	
<b>SEER2</b>	20	<b>HSPF2-4</b>	10.8
<b>EER2</b>	12.0	<b>COP</b>	3.29

**PERFORMANCE of Cooling**

Cooling (Btu/hr)	
<b>Rated Capacity</b>	36400
<b>Min/Max Capacity</b>	6100~38300
<b>Moisture Removal(L/h)</b>	3.10
<b>Standard Operating Range(°F/°C)</b>	-22~122(-30~50)
Conditions:	Indoor: 80°F DB/67°F WB Outdoor: 95°F DB/75°F WB

**PERFORMANCE of Heating**

Heating (Btu/hr)	
<b>1. @ 47°F Rated</b>	38000
<b>1. @ 47°F Min/Max Capacity</b>	11100~45400
<b>2. @ 17°F Rated</b>	30200
<b>3. @ 5°F Rated: Capacity / COP</b>	39500/2.02
<b>3. @ 5°F Max: Capacity</b>	39500
<b>Standard Operating Range(°F/°C)</b>	-22~75(-30~24)
1. Conditions:	Indoor: 70°F DB/60°F WB Outdoor: 47°F DB/43°F WB
2. Conditions:	Indoor: 70°F DB/60°F WB Outdoor: 17°F DB/15°F WB
3. Conditions:	Indoor: 70°F DB/60°F WB Outdoor: 5°F DB/5°F WB

**ELECTRICAL**

<b>Power Supply</b>	208/230V,60Hz,1Ph
<b>System MCA</b>	38.00
<b>Connection Wiring</b>	14#x3
<b>System MOCP</b>	40
<b>Compressor RLA</b>	24.5
<b>Outdoor Fan Motor RLA</b>	2.1
<b>Outdoor Fan Motor W</b>	250
<b>Indoor Fan Motor RLA</b>	1.0
<b>Indoor Fan Motor W</b>	90
<b>System Power Input @ Cooling (W)</b>	3033(590 ~ 3610)
<b>System Power Input @ Heating (W)</b>	3385(675 ~ 4070)
<b>MCA: Min. circuit amps (A)</b>	<b>MOCP: Max. over current protection (A)</b>
<b>RLA: Rated load amps (A)</b>	<b>W: Fan motor rated output (W)</b>

**PIPING**

<b>Throttle type(Indoor)</b>	N/A
<b>Throttle type(Outdoor)</b>	EXV+Throttle valve
<b>Liquid Size</b>	9.52mm(3/8in)
<b>Gas Size</b>	19mm(3/4in)
<b>Max. Piping Length(ft/m)</b>	246.00(75)
<b>Max. Height Difference(ft/m)</b>	98.40(30)
<b>Max. Pre-charged Length(ft/m)</b>	24.6(7.5)
<b>Refrigerant Pre-charged Amount(oz/kg)</b>	126.99(3.60)
<b>Additional Charge of Refrigerant((oz/ft)/(g/m))</b>	0.32(30)
<b>Connection Method</b>	Flared

## Indoor Unit Dimension

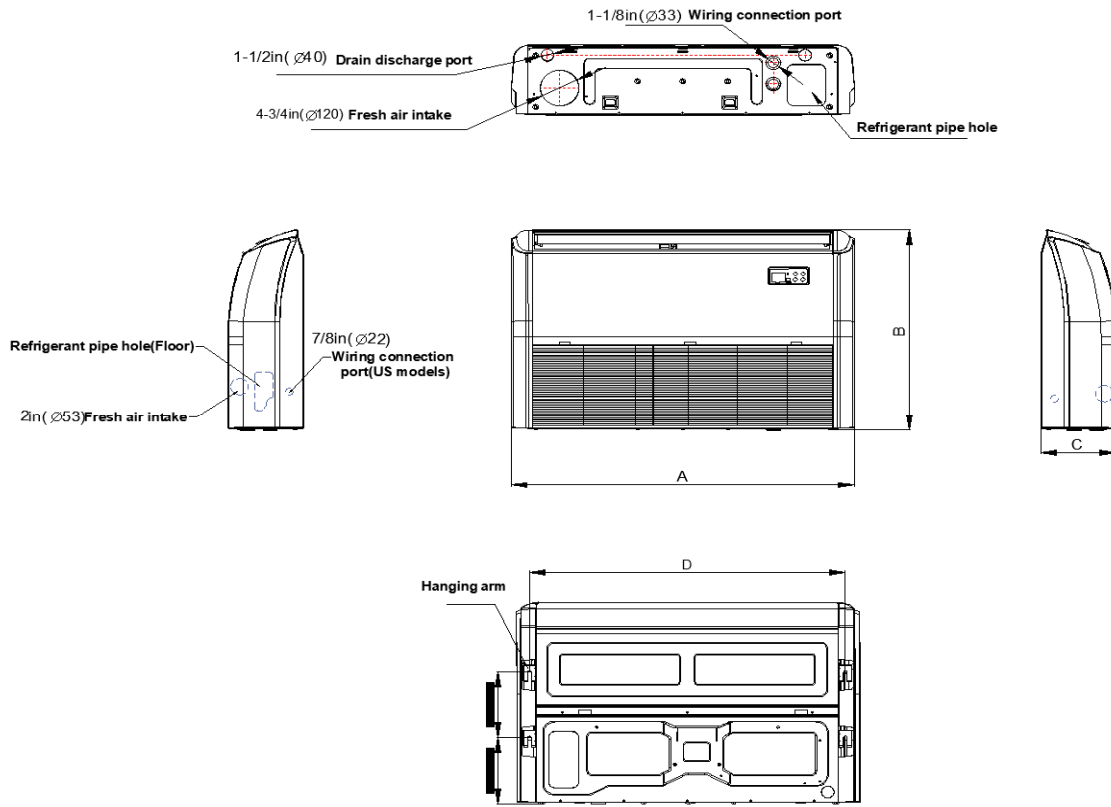

Model	A	B	C	D
18K/24K	42in(1068mm)	26-1/2in(675mm)	9-1/4in(235mm)	38-3/4in(983mm)
36K/48K/60K	65in(1650mm)	26-1/2in(675mm)	9-1/4in(235mm)	61-5/8in(1565mm)

## Installation Instruction

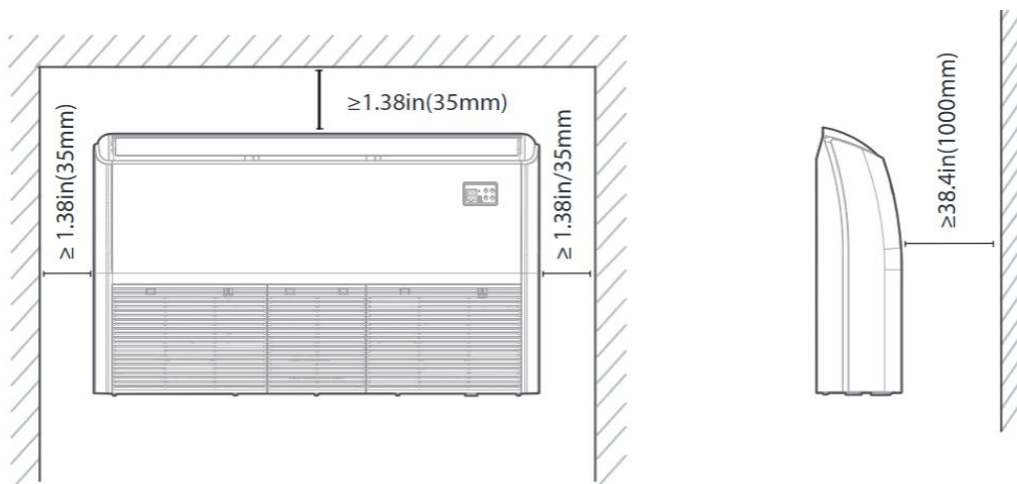

### Outdoor Unit Dimension

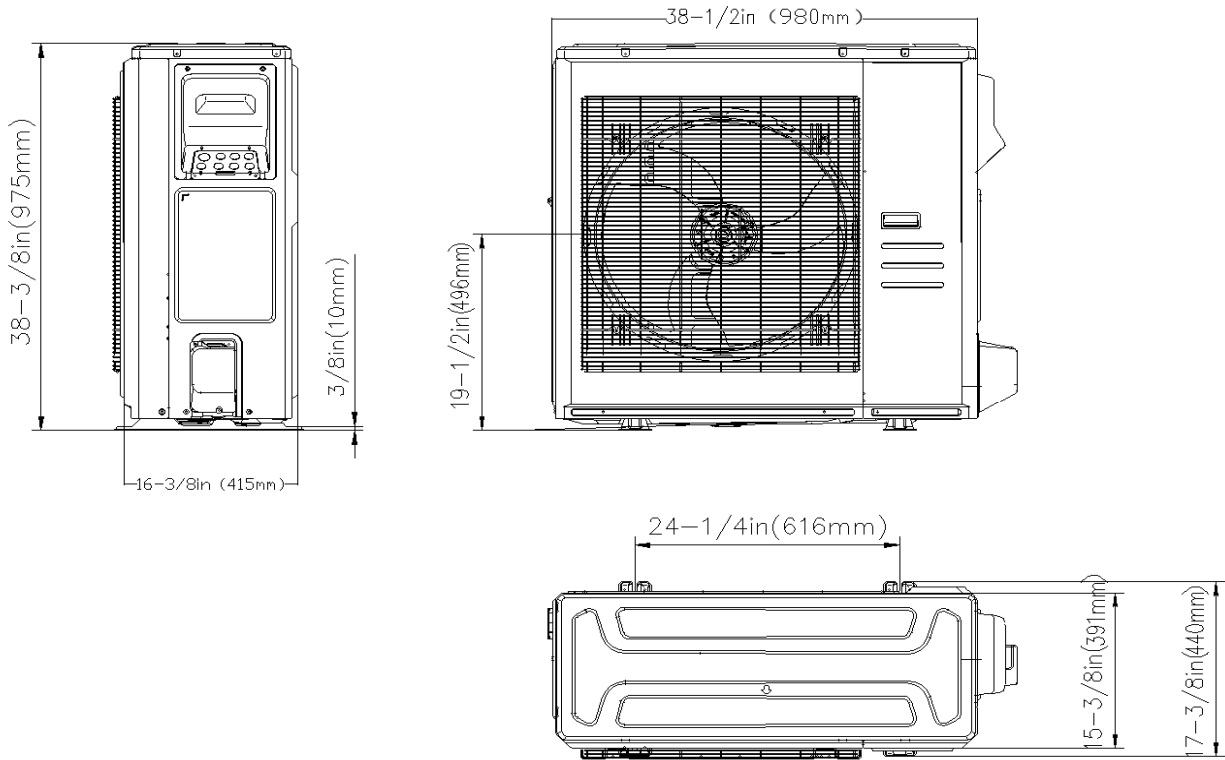

### Installation Instruction

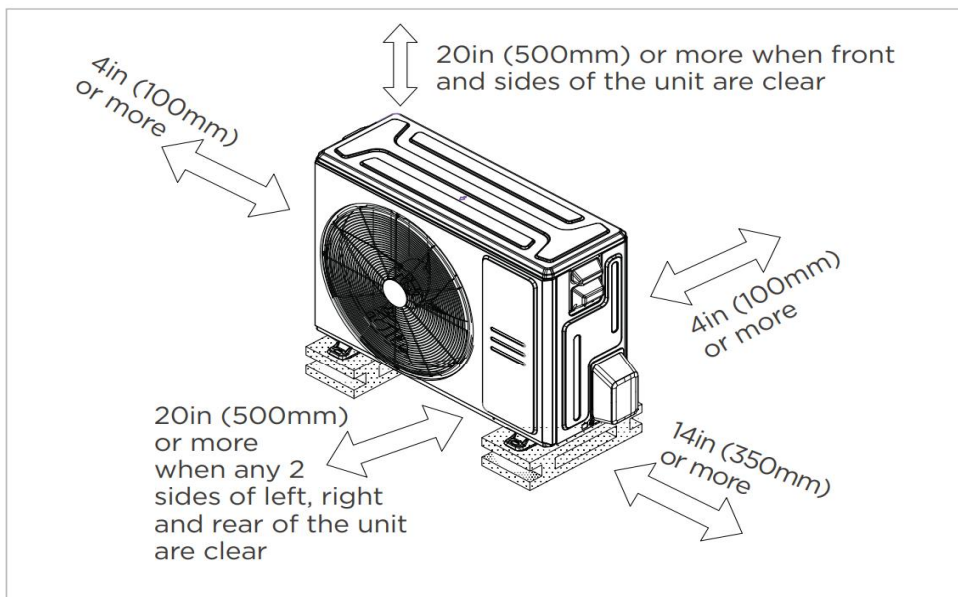

Meets all spatial requirements shown in Installation Clearance Requirements above.

## FEATURES

- 2 Style Installation
- 3D Airflow
- Refrigerant leakage detection sensor
- Humidity sensor
- “88” display tube
- 1~100% fan speed setting
- WiFi capability: through WiFi dongle or wired controller with built-in WiFi
- OTA(by using WiFi dongle)
- 2-pin connector(HA/HB) for programmable wired controller
- Multiple control options available:
  - Two way communication wired controller with built-in WiFi:AWC-8P-LC-WIFI
  - Infrared wired controller: AWC-4
  - Wireless remote controller
  - Third-Party 24V Thermostat

\*24V interface is required.