

# Submittal

TAG: \_\_\_\_\_

PRODUCT NAME \_\_\_\_\_  
LOCATION \_\_\_\_\_  
ARCHITECT \_\_\_\_\_  
ENGINEER \_\_\_\_\_  
CONTRACTOR \_\_\_\_\_  
SUBMITTED BY \_\_\_\_\_ DATA \_\_\_\_\_

## UNIT SUMMARY

Quantity						
Unit Designation						
Model No.						
Cooling Input						
Cooling Output						
CFM/ESP						
Electrical						
Minimum Ampacity						
Max Overcurrent Protection						
Net Unit Weight						
Accessory						
Catalog Form Number						

### ACCESSORIES

### NOTES

# High-Efficiency Air Handlers

## LCM7 Series

Cooling capacity: 36 kBTU/h

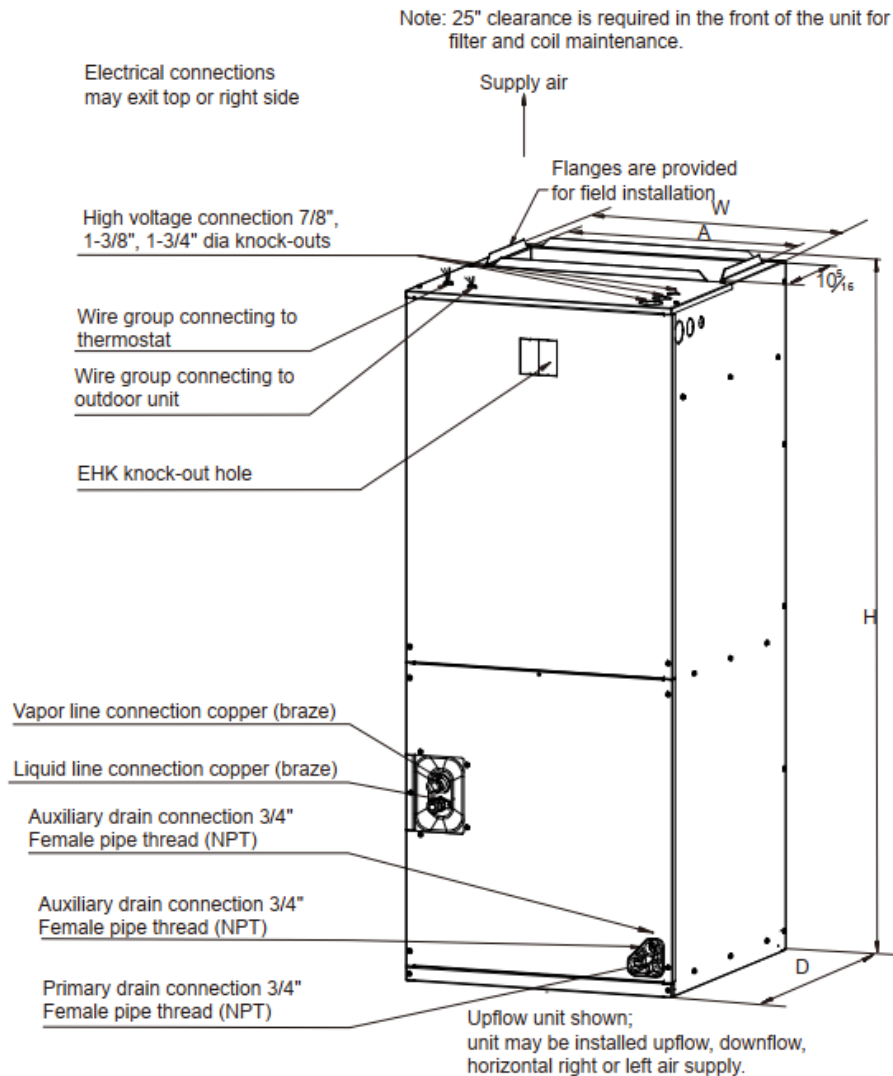

Model Size	Unit Height "H" in. [mm]	Unit Width "W" in. [mm]	Unit Length "D" in. [mm]	Supply Duct "A"	Unit Weight (lbs.[kg])
24	41-3/8 [1050]	18-1/8 [460]	20-1/2 [520]	16 [406]	101 [46]
36	46-1/2 [1180]	19-5/8 [500]	21-5/8 [550]	18 [456]	121 [55]
48	54-1/2 [1385]	22 [560]	24 [610]	19-1/2 [496]	151 [69]
60	54-1/2 [1385]	22 [560]	24 [610]	19-1/2 [496]	159 [72]
61	54-1/2 [1385]	22 [560]	24 [610]	19-1/2 [496]	161 [73]

# Specifications

	LCM7-36-15
<b>NOMINAL RATING</b>	
Cooling (BTU/h)	34200
CFM (High/Low range)	1240
External Static Pressure (in.w.c) [Pa]	0.58 [145]
<b>ELECTRICAL DATA</b>	
Voltage / Phase(60Hz)	208V/230V-1ph-60Hz
Min. / Max. Voltage (V)	187/253
Min. Circuit Amps (MCA) (A)	4.2
Max. Overcurrent Protection (MOP) (A)	15
<b>FAN MOTOR</b>	
Motor Type	ECM
Capacitor (uF)	/
Horsepower (HP)	1/2
Rated RPM	1050
MOC	3.3
<b>FAN BLOWER</b>	
Material	Metal
Type	Centrifugal
Diameter(in.) [mm]	10 [278.5]
Height(in.) [mm]	10 [271]
Coil Drain Connection FPT (in.)	3/4
<b>EVAPORATOR COIL</b>	
Type	Aluminum-Hydrophilic Aluminum
Tube Material	Aluminum
Tube Size (in.)	9/32
<b>SOUND POWER (dB)</b>	
	70
<b>REFRIGERANT CONNECTION SIZE</b>	
Liquid Line Size (O.D.) (in.)	3/8
Suction Line Size (O.D.) (in.)	3/4
<b>DIMENSIONS</b>	
Width (In.) [mm]	19-5/8 [500]
Height (In.) [mm]	46-1/2 [1180]
Depth (In.) [mm]	21-5/8 [550]
Packaged dimension (W × H × D) (In.) [mm]	22-5/16 × 47-1/8 × 25-3/8 [567 × 1197 × 644]
<b>SERVICE VALVE</b>	
Liquid (in.)	3/8
Suction (in.)	3/4
<b>WEIGHT</b>	
Net weight (lbs.) [kg]	121 [55]
Shipping weight (lbs.) [kg]	134 [61]

# Airflow Data

Model Number	Outdoor Unit Size (Ton)	Motor Speed		CFM Wet Coil Without Filter and Electric Heat								
				External Static Pressure (in w.c.)								
				0	0.1	0.2	0.3	0.4	0.5	0.6	0.7	0.8
24	1.5	1	Current / A	0.63	0.67	0.7	0.74	0.77	0.81	0.84	0.88	0.9
			Power / W	72	78	82	87	92	97	102	107	112
			CFM	676	608	550	492	422	369	311	274	233
		2	Current / A	0.81	0.85	0.89	0.93	0.97	1	1.04	1.09	1.12
			Power / W	98	103	109	114	120	124	130	136	140
			CFM	770	717	666	615	552	512	457	406	364
		3	Current / A	1.14	1.18	1.22	1.26	1.31	1.36	1.41	1.45	1.49
			Power / W	143	148	154	159	166	172	178	183	189
			CFM	903	856	808	767	722	665	618	577	535
		4	Current / A	1.42	1.46	1.51	1.55	1.6	1.65	1.69	1.75	1.8
			Power / W	179	185	191	197	203	210	215	223	229
			CFM	987	945	900	861	821	766	737	677	636
		5	Current / A	1.66	1.71	1.76	1.81	1.86	1.91	1.95	2	2.06
			Power / W	211	217	224	230	237	244	249	255	264
			CFM	1055.6	1012.3	970.6	930.3	883.4	844.9	811.8	774.8	715.3
24	2	1	Current / A	0.63	0.67	0.7	0.74	0.77	0.81	0.84	0.88	0.9
			Power / W	72	78	82	87	92	97	102	107	112
			CFM	676	608	550	492	422	369	311	274	233
		2	Current / A	0.81	0.85	0.89	0.93	0.97	1	1.04	1.09	1.12
			Power / W	98	103	109	114	120	124	130	136	140
			CFM	770	717	666	615	552	512	457	406	364
		3	Current / A	1.14	1.18	1.22	1.26	1.31	1.36	1.41	1.45	1.49
			Power / W	143	148	154	159	166	172	178	183	189
			CFM	903	856	808	767	722	665	618	577	535
		4	Current / A	1.42	1.46	1.51	1.55	1.6	1.65	1.69	1.75	1.8
			Power / W	179	185	191	197	203	210	215	223	229
			CFM	987	945	900	861	821	766	737	677	636
		5	Current / A	1.66	1.71	1.76	1.81	1.86	1.91	1.95	2	2.06
			Power / W	211	217	224	230	237	244	249	255	264
			CFM	1056	1012	971	930	883	845	812	775	715
36	2.5	1	Current / A	1.05	1.09	1.14	1.19	1.27	1.33	1.4	/	/
			Power / W	113	119	126	133	144	151	158	/	/
			CFM	1013	946	891	823	709	634	566	/	/
		2	Current / A	1.45	1.5	1.56	1.61	1.66	1.76	1.83	1.89	1.95
			Power / W	166	174	181	188	195	208	218	255	234
			CFM	1180	1123	1072	1023	969	865	794	733	674
		3	Current / A	1.87	1.93	1.99	2.05	2.1	2.15	2.25	2.35	2.42
			Power / W	224	232	240	248	255	262	276	288	299
			CFM	1335	1283	1231	1189	1146	1093	1009	923	864
		4	Current / A	2.42	2.49	2.55	2.61	2.67	2.73	2.79	2.87	2.99
			Power / W	299	308	317	325	334	342	350	361	378
			CFM	1484	1437	1386	1347	1309	1271	1231	1176	1075
		5	Current / A	2.92	2.99	3.07	3.14	3.19	3.25	3.35	3.49	3.50
			Power / W	369	378	388	397	404	411	424	441	443
			CFM	1560	1520	1480	1442	1403	1378	1323	1248	1179
36	3	1	Current / A	1.05	1.09	1.14	1.19	1.27	1.33	1.4	/	/
			Power / W	113	119	126	133	144	151	158	/	/
			CFM	1013	946	891	823	709	634	566	/	/
		2	Current / A	1.45	1.5	1.56	1.61	1.66	1.76	1.83	1.89	1.95
			Power / W	166	174	181	188	195	208	218	225	234
			CFM	1180	1123	1072	1023	969	865	794	733	674
		3	Current / A	1.87	1.93	1.99	2.05	2.1	2.15	2.25	2.35	2.42
			Power / W	224	232	240	248	255	262	276	288	299

		4	CFM	1335	1283	1231	1189	1146	1093	1009	923	864		
			Current / A	2.42	2.49	2.55	2.61	2.67	2.73	2.79	2.87	2.99		
			Power / W	299	308	317	325	334	342	350	361	378		
		5	CFM	1484	1437	1386	1347	1309	1271	1231	1176	1075		
			Current / A	2.92	2.99	3.07	3.14	3.19	3.25	3.35	3.49	3.50		
			Power / W	369	378	388	397	404	411	424	441	443		
		48/60	3.5	1	CFM	1560	1520	1480	1442	1403	1378	1323	1248	1179
					Current / A	1.56	1.63	1.71	1.77	1.83	1.90	2.02	2.10	/
					Power / W	198	209	220	226	231	241	260	270	/
2	CFM			1420	1374	1320	1269	1218	1158	1037	957	/		
	Current / A			2.10	2.20	2.28	2.34	2.39	2.46	2.54	2.63	2.78		
	Power / W			267	279	289	297	303	312	322	334	353		
3	CFM			1613	1558	1516	1469	1425	1375	1327	1274	1147		
	Current / A			2.78	2.87	2.96	3.03	3.10	3.17	3.25	3.32	3.41		
	Power / W			369	383	398	408	419	428	439	450	465		
4	CFM			1796	1757	1707	1663	1622	1580	1539	1467	1451		
	Current / A			3.46	3.55	3.67	3.75	3.84	3.92	3.99	4.07	4.15		
	Power / W			472	482	502	513	523	537	548	560	573		
5	CFM			1978	1944	1887	1850	1805	1765	1722	1678	1632		
	Current / A			4.17	4.26	4.38	4.47	4.57	4.67	4.74	4.83	4.92		
	Power / W			575	590	605	621	634	651	662	675	690		
48/60	4			1	CFM	2123	2092	2051	2011	1971	1922	1889	1852	1818
					Current / A	1.56	1.63	1.71	1.77	1.83	1.90	2.02	2.10	/
					Power / W	198	209	220	226	231	241	260	270	/
		2	CFM	1420	1374	1320	1269	1218	1158	1037	957	/		
			Current / A	2.10	2.20	2.28	2.34	2.39	2.46	2.54	2.63	2.78		
			Power / W	281	294	305	313	319	329	339	351	371		
		3	CFM	1613	1558	1516	1469	1425	1375	1327	1274	1147		
			Current / A	2.78	2.87	2.96	3.03	3.10	3.17	3.25	3.32	3.41		
			Power / W	369	383	398	408	419	428	439	450	465		
		4	CFM	1796	1757	1707	1663	1622	1580	1539	1467	1451		
			Current / A	3.46	3.55	3.67	3.75	3.84	3.92	3.99	4.07	4.15		
			Power / W	472	482	502	513	523	537	548	560	573		
		5	CFM	1978	1944	1887	1850	1805	1765	1722	1678	1632		
			Current / A	4.17	4.26	4.38	4.47	4.57	4.67	4.74	4.83	4.92		
			Power / W	575	590	605	621	634	651	662	675	690		
		48/60	5	1	CFM	2123	2092	2051	2011	1971	1922	1889	1852	1818
					Current / A	1.56	1.63	1.71	1.77	1.83	1.90	2.02	2.10	/
					Power / W	198	209	220	226	231	241	260	270	/
2	CFM			1420	1374	1320	1269	1218	1158	1037	957	/		
	Current / A			2.10	2.20	2.28	2.34	2.39	2.46	2.54	2.63	2.78		
	Power / W			267	279	289	297	303	312	322	334	353		
3	CFM			1613	1558	1516	1469	1425	1375	1327	1274	1147		
	Current / A			2.78	2.87	2.96	3.03	3.10	3.17	3.25	3.32	3.41		
	Power / W			369	383	398	408	419	428	439	450	465		
4	CFM			1796	1757	1707	1663	1622	1580	1539	1467	1451		
	Current / A			3.46	3.55	3.67	3.75	3.84	3.92	3.99	4.07	4.15		
	Power / W			472	482	502	513	523	537	548	560	573		
5	CFM			1978	1944	1887	1850	1805	1765	1722	1678	1632		
	Current / A			4.17	4.26	4.38	4.47	4.57	4.67	4.74	4.83	4.92		
	Power / W			575	590	605	621	634	651	662	675	690		
61	6			1	CFM	2123	2092	2051	2011	1971	1922	1889	1852	1818
					Current / A	1.56	1.63	1.71	1.77	1.83	1.90	2.02	2.10	/
					Power / W	198	209	220	226	231	241	260	270	/
		2	CFM	1420	1374	1320	1269	1218	1158	1037	957	/		
			Current / A	2.10	2.20	2.28	2.34	2.39	2.46	2.54	2.63	2.78		
			Power / W	267	279	289	297	303	312	322	334	353		
		3	CFM	1613	1558	1516	1469	1425	1375	1327	1274	1147		
			Current / A	2.78	2.87	2.96	3.03	3.10	3.17	3.25	3.32	3.41		
			Power / W	369	383	398	408	419	428	439	450	465		
		4	CFM	1796	1757	1707	1663	1622	1580	1539	1467	1451		
			Current / A	3.46	3.55	3.67	3.75	3.84	3.92	3.99	4.07	4.15		
			Power / W	472	482	502	513	523	537	548	560	573		
		5	CFM	1978	1944	1887	1850	1805	1765	1722	1678	1632		
			Current / A	4.17	4.26	4.38	4.47	4.57	4.67	4.74	4.83	4.92		
			Power / W	575	590	605	621	634	651	662	675	690		
		61	6	1	CFM	1587	1537	1492	1435	1401	1348	1293	1180	1116
					Current / A	1.58	1.64	1.72	1.78	1.85	1.96	2.03	2.10	2.15
					Power / W	199	208	220	229	237	250	260	270	280
2	Current / A			2.11	2.21	2.28	2.36	2.41	2.48	2.56	2.70	2.77		
	Power / W			273	289	298	310	318	329	340	360	370		
	CFM			1587	1537	1492	1435	1401	1348	1293	1180	1116		

		3	Current / A	2.78	2.84	2.92	3.04	3.10	3.18	3.26	3.32	3.43
			Power / W	372	380	391	406	415	428	439	450	465
			CFM	1782	1769	1691	1643	1610	1564	1523	1484	1424
		4	Current / A	3.47	3.55	3.64	3.73	3.93	3.90	4.00	4.07	3.94
			Power / W	470	480	492	510	521	530	550	560	571
			CFM	1962	1931	1885	1844	1798	1764	1715	1683	1635
		5	Current / A	4.26	4.30	4.38	4.45	4.52	4.64	4.74	4.83	4.92
			Power / W	589	590	605	617	628	642	660	670	688
			CFM	2123	2075	2034	1996	1962	1919	1882	1844	1805

--- Shaded boxes represent airflow outside the required 300 to 450 cfm/ton, which are not recommended.

NOTES: Airflow based upon cooling performance at 230V with no electric heat or filter. Airflow at 208V is approximately the same as 230V because the multi-tap ECM motor provides constant torque with no drop off relative to motor operating speed.

The air distribution system has the greatest effect on airflow and is in the control of the installing contractor. For this reason, the contractor should use only industry-recognized procedures.

Heat pump systems require a specified airflow for electric heat operating. Each ton of cooling requires between 350 and 450 cubic feet of air per minute (CFM), or 400 CFM nominally.

Duct design and construction should be carefully done. System performance can be lowered dramatically through poor planning or workmanship.

Air supply diffusers must be selected and located carefully. They must be sized and positioned to deliver treated air along the perimeter of the space. If they are too small for their intended airflow, they would become noisy. If they are not located properly, they cause drafts. Return air grilles must be properly sized to carry air back to the blower. If they are too small, they also can cause noise.

Installers should balance the air distribution system to ensure sufficient, quiet airflow to all spaces to ensure maximum occupant comfort.

An air velocity meter or airflow hood can be used to balance and verify branch and system airflow (CFM).

## Features

- High heat-transfer efficiency and low static-pressure drop A-shaped coil.
- Foil-faced insulation to prevent energy loss through the cabinet.
- Factory-sealed cabinet certified to achieve 2% or less air leakage rate at 1.0-inch water column.
- Multi-stage blower Speed Control to align with varying capacity demands.
- Multi-speed constant-torque ECM motor.
- 4-position installation: Upflow, Horizontal Right, Downflow, Horizontal Left.
- Horizontal and vertical condensate drain pans standard, primary and secondary condensate fittings.
- Field-installed electric heater kits 5, 7.5, 10, 15, 20 kW available as accessories. Multiple electrical entry locations.
- Dual front panel, volute and coil with slide track, TXV with threaded connection for easy maintenance.
- Integrated filter rack with toolless door access.
- Easy-to-braze copper evaporator connection.
- TXV designed for easy piston replacement.
- All-aluminum heat exchanger extends product lifetime.
- Advanced internal welding process to reduce potential corrosion.
- AHRI and ETL listed.
- Polymer condensate drain pan with UVC inhibitor to extends product lifetime.
- Fully-insulated cabinet design.
- R454B refrigerant sensor ensures safe operation.
- R454B refrigerant sensor is factory-installed, making unit suitable for more room types and applications.

**ComfortStar®**

Add.: 12201 N W 107th Avenue Miami, FL 33178

1.866.524.9898 Toll Free

305.500.9898 Office

305.500.9896 Fax document.

<http://www.comfortstarusa.com>