

Submittal

TAG: _____

PRODUCT NAME _____
LOCATION _____
ARCHITECT _____
ENGINEER _____
CONTRACTOR _____
SUBMITTED BY _____ DATA _____

UNIT SUMMARY

Quantity						
Unit Designation						
Model No.						
Cooling Input						
Cooling Output						
CFM/ESP						
Electrical						
Minimum Ampacity						
Max Overcurrent Protection						
Net Unit Weight						
Accessory						
Catalog Form Number						

ACCESSORIES

NOTES

High-Efficiency Air Handlers

LUC7 Series

Cooling capacity: 18 kBTU/h

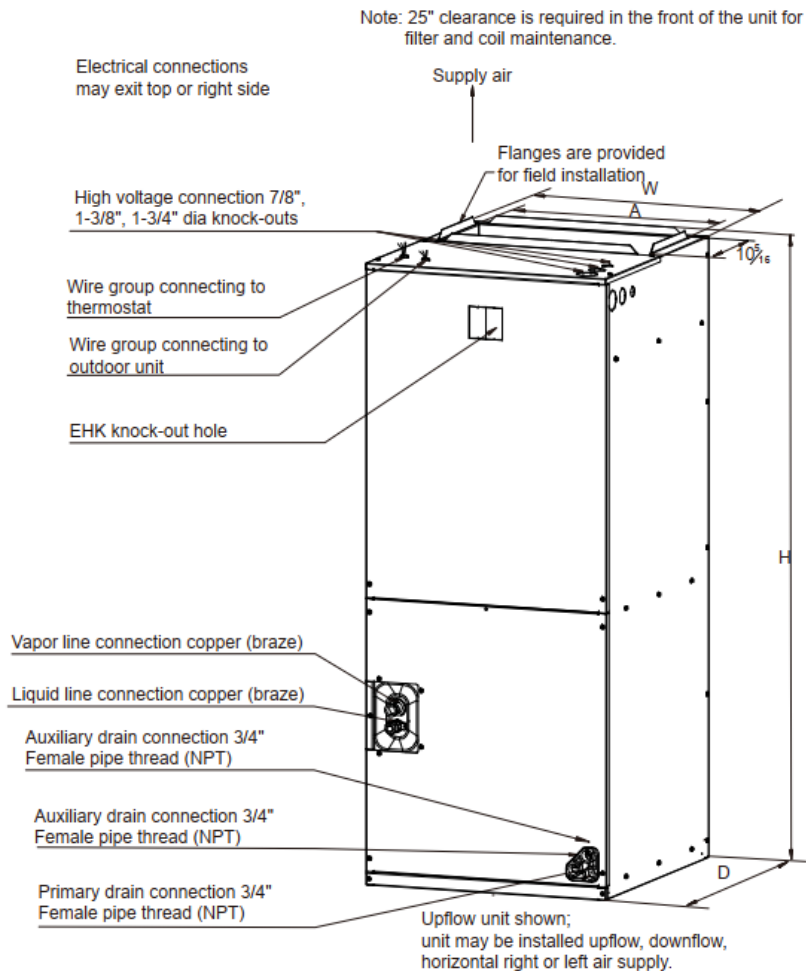

Model Size	Unit Height "H" in. [mm]	Unit Width "W" in. [mm]	Unit Length "D" in. [mm]	Supply Duct "A"	Unit Weight (lbs.[kg])
18	41-3/8" [1050]	18-1/8" [460]	20-1/2" [520]	16" [406]	108 [49]
24	46-1/2" [1180]	19-5/8" [500]	21-5/8" [550]	18" [456]	130 [59]
36	46-1/2" [1180]	19-5/8" [500]	21-5/8" [550]	18" [456]	130 [59]
48	54-1/2" [1385]	22" [560]	24" [610]	19-1/2" [496]	159 [72]
60	54-1/2" [1385]	22" [560]	24" [610]	19-1/2" [496]	163 [74]

Specifications

		LUC7-18-15
NOMINAL RATING		
Cooling (BTU/h)		18000
CFM (High/Low range)		600
External Static Pressure (in.w.c) [Pa]		0.58 [145]
ELECTRICAL DATA		
Voltage / Phase(60Hz)		208V/230V-1ph-60Hz
Min. / Max. Voltage (V)		187/253
Min. Circuit Amps (MCA) (A)		1.8
Max. Overcurrent Protection (MOP) (A)		15
FAN MOTOR		
Motor Type		PSC
Capacitor (uF)		6
Horsepower (HP)		1/5
Rated RPM		755
Full Load Amps (FLA) (A)		1.4
FAN BLOWER		
Material		Metal
Type		Centrifugal
Diameter(in.) [mm]		10 [278.5]
Height(in.) [mm]		8 [207]
Coil Drain Connection FPT (in.)		3/4
EVAPORATOR COIL		
Type		Aluminum-Hydrophilic Aluminum
Tube Material		Aluminum
Tube Size (in.)		9/32
SOUND POWER (dB)		65
REFRIGERANT CONNECTION SIZE		
Liquid Line Size (O.D.) (in.)		3/8
Suction Line Size (O.D.) (in.)		3/4
DIMENSIONS		
Width (In.) [mm]		18-1/8 [460]
Height (In.) [mm]		41-3/8 [1050]
Depth (In.) [mm]		20-1/2 [520]
packaging dimension (W x H x D) (In.) [mm]		20-3/4 x 42 x 24-3/16 [527 x 1067 x 614]
Service Valve		
Liquid (in.)		3/8
Suction (in.)		3/4
Weight		
Net weight (lbs.) [kg]		108 [49]
Shipping weight (lbs.) [kg]		121 [55]

Airflow Data

Model Number	Outdoor Unit Size (Ton)	Motor Speed	CFM Wet Coil Without Filter and Electric Heat											
			External Static Pressure (in w.c)											
			0	0.1	0.2	0.3	0.4	0.5	0.6	0.7	0.8			

18	1.5	Low	Current / A	0.90	0.89	0.87	0.85	0.83	0.81	0.79	0.75	0.7
			Power / W	2507	203	198	191	187	182	173	162	151
			CFM	649	618	586	548	509	467	420	350	283
		Medium	Current / A	1.04	1.01	0.99	0.97	0.94	0.92	0.89	0.87	0.82
			Power / W	243	236	230	224	218	210	204	198	184
			CFM	815	796	758	720	677	624	573	522	421
		High	Current / A	1.34	1.31	1.28	1.25	1.22	1.19	1.15	1.12	1.09
			Power / W	313	305	297	289	280	270	259	250	242
			CFM	945	933	897	855	811	757	692	633	566
24	2	Low	Current / A	1.28	1.25	1.23	1.20	1.17	1.14	1.11	1.08	1.0
			Power / W	289	281	274	265	253	244	234	223	206
			CFM	1081	1028	977	909	796	714	628	539	407
		Medium	Current / A	1.37	1.35	1.33	1.32	1.28	1.24	1.21	1.17	1.14
			Power / W	315	309	303	297	287	274	263	252	242
			CFM	1231	1176	1122	1068	976	851	757	659	552
		High	Current / A	1.88	1.84	1.8	1.77	1.74	1.7	1.64	1.59	1.55
			Power / W	423	409	399	389	380	364	344	329	314
			CFM	1434	1371	1311	1249	1185	1081	922	807	689
36	3	Low	Current / A	1.53	1.53	1.52	1.50	1.48	1.45	1.43	1.40	/
			Power / W	323	319	314	307	294	281	268	251	/
			CFM	1091	1048	1001	947	851	764	677	571	/
		Medium	Current / A	1.72	1.71	1.7	1.68	1.67	1.64	1.62	1.59	/
			Power / W	368	361	354	348	339	325	312	297	/
			CFM	1335	1286	1230	1172	1103	986	866	752	/
		High	Current / A	2.27	2.26	2.24	2.22	2.21	2.18	2.15	2.12	/
			Power / W	473	462	452	442	430	419	399	383	/
			CFM	1526	1467	1403	1335	1259	1181	1030	913	/
48	4	Low	Current / A	2.30	2.25	2.21	2.18	2.14	2.10	2.05	1.92	1.85
			Power / W	491	472	456	442	430	417	399	351	328
			CFM	1496	1441	1383	1326	1273	1214	1137	872	746
		Medium	Current / A	2.56	2.52	2.48	2.44	2.40	2.37	2.33	2.28	2.12
			Power / W	562	548	535	523	509	497	482	465	410
			CFM	1798	1731	1660	1597	1529	1452	1376	1283	921
		High	Current / A	3.30	3.25	3.20	3.15	3.10	3.05	3.00	2.95	2.88
			Power / W	704	689	673	656	640	624	610	593	570
			CFM	1970	1896	1819	1737	1662	1580	1501	1411	1291
60	5	Low	Current / A	3.09	2.95	2.87	2.81	2.73	2.66	2.58	2.48	2.2
			Power / W	716	682	662	647	627	610	590	565	495
			CFM	1872	1802	1747	1687	1628	1567	1500	1416	1140
		Medium	Current / A	1.15	1.08	1.01	0.95	0.88	0.82	0.94	0.85	0.97
			Power / W	751	729	711	694	675	657	638	617	592
			CFM	2080	2012	1948	1886	1821	1753	1684	1604	1505
		High	Current / A	3.70	3.60	3.53	3.42	3.34	3.26	3.17	3.08	2.99
			Power / W	858	833	817	792	771	751	731	710	687
			CFM	2198	2120	2068	1979	1908	1836	1760	1677	1584

--- Shaded boxes represent airflow outside the required 300 to 450 cfm/ton, which are not recommended.

NOTES: Airflow based upon cooling performance at 230V with no electric heat and no filter.

The air distribution system has the greatest effect on airflow. The duct system is totally controlled by the contractor. For this reason, the contractor should use only industry-recognized procedures.

Heat pump systems require a specified airflow for electric heat operating. Each ton of cooling requires between 350 and 450 cubic feet of air per minute (CFM), or 400 CFM nominally.

Duct design and construction should be carefully done. System performance can be lowered dramatically through bad planning or workmanship.

Air supply diffusers must be selected and located carefully. They must be sized and positioned to deliver treated air along the perimeter of the space. If they are too small for their intended airflow, they become noisy. If they are not located properly, they cause drafts. Return air grilles must be properly sized to carry air back to the blower. If they are too small, they also cause noise.

The installers should balance the air distribution system to ensure proper quiet airflow to all rooms in the home. This ensures a comfortable living space.

An air velocity meter or airflow hood can be used to balance and verify branch and system airflow (CFM).

IMPORTANT:

1. If unit is converted to downflow, the airflow for model 18 must be between 350 and 450 cfm/ton.
2. When model 42 used for mobile home, you need to ensure that the air volume is not less than 1335 CFM.
3. When model 48 used for mobile home, you need to ensure that the air volume is not less than 1584 CFM.

Features

- High heat-transfer efficiency and low static-pressure drop A-shaped coil.
- Foil-faced insulation to prevent energy loss through the cabinet.
- Factory-sealed cabinet certified to achieve 2% or less air leakage rate at 1.0-inch water column.
- Multi-stage blower Speed Control to align with varying capacity demands.
- 4-position installation: Upflow, Horizontal Right, Downflow, Horizontal Left.
- Horizontal and vertical condensate drain pans standard, primary and secondary condensate fittings.
- Field-installed electric heater kits 5, 7.5, 10, 15, 20 kW available as accessories. Multiple electrical entry locations.
- Dual front panel, volute and coil with slide track, TXV with threaded connection for easy maintenance.
- Integrated filter rack with toolless door access.
- Easy-to-braze copper evaporator connection.
- TXV designed for easy piston replacement.
- All-aluminum heat exchanger extends product lifetime.
- Advanced internal welding process to reduce potential corrosion.
- AHRI and ETL listed.
- Polymer condensate drain pan with UVC inhibitor to extends product lifetime.
- Fully-insulated cabinet design.
- R454B refrigerant sensor ensures safe operation.
- R454B refrigerant sensor is factory-installed, making unit suitable for more room types and applications.

ComfortStar®

Add.: 12201 N W 107th Avenue Miami, FL 33178

1.866.524.9898 Toll Free

305.500.9898 Office

305.500.9896 Fax document.

<http://www.comfortstarusa.com>