

4-Way Cassette Heat Pump System

Location:	Approval:
Engineer:	Date:
Submitted to:	Construction:
Submitted by:	Unit #:
Reference:	Drawing #:



INDOOR SPEINDOOR SPECIFICATIONCIFICATION

Indoor Air Flow (Turbo/H/M/L/Si) (CFM)	353.2 / 312.0 / 264.9 / 182.5 / 147.2	
Indoor Noise Level (Turbo/H/M/L/Si) (dBA)	42.5/40.0/37.5/26.0/24.0	
Dimension (W×D×H)	inch	22.44 x 22.44 x 9.65
	mm	570.0×570.0×245.0
Package (W×D×H)	inch	28.15 x 25.20 x 11.61
	mm	715×640×295
Net/Gross Weight	lbs	35.27/41.89
	kg	16/19

OUTDOOR SPECIFICATION

Compressor Type	ROTARY	
Compressor Model	KTN110D42UFZ	
Refrigerant	R454B	
Refrigerant Oil Charge(mL)	350	
Refrigerant Oil	VG74	
Outdoor Air Flow (Max) (CFM)	1471.5	
Outdoor Noise Level (dBA)	55.0	
Dimension (W×D×H)	inch	31.69 x 12.99 x 21.81
	mm	805.0×330.0×554.0
Package (W×D×H)	inch	36.02 x 14.57 x 24.21
	mm	915×370×615
Net/Gross Weight	lbs	72.75/78.70
	kg	33/35.7

EFFICIENCY

Cooling		Heating	
SEER2	22.6	HSPF2-4	12.1
EER2	14.0	COP	4.00

PERFORMANCE of Cooling

Cooling (Btu/hr)	
Rated Capacity	9000
Min/Max Capacity	3700~13600
Moisture Removal(L/h)	0.88
Standard Operating Range(°F/°C)	-22~-122(-30~-50)
Conditions:	Indoor: 80°F DB/67°F WB Outdoor: 95°F DB/75°F WB

PERFORMANCE of Heating

Heating (Btu/hr)	
1. @ 47°F Rated	10000
1. @ 47°F Min/Max Capacity	5100~15700
2. @ 17°F Rated	9700
3. @ 5°F Rated: Capacity / COP	11000/1.84
3. @ 5°F Max: Capacity	11000
Standard Operating Range(°F/°C)	-22~-75(-30~-24)
1. Conditions:	Indoor: 70°F DB/60°F WB Outdoor: 47°F DB/43°F WB
2. Conditions:	Indoor: 70°F DB/60°F WB Outdoor: 17°F DB/15°F WB
3. Conditions	Indoor: 70°F DB/60°F WB Outdoor: 5°F DB/5°F WB

ELECTRICAL

Power Supply	208/230V,60Hz,1Ph
System MCA	15.00
Connection Wiring	14#x4
System MOCP	15
Compressor RLA	10.4
Outdoor Fan Motor RLA	0.6
Outdoor Fan Motor W	34
Indoor Fan Motor RLA	0.8
Indoor Fan Motor W	45
System Power Input @ Cooling (W)	643(200 ~ 1150)
System Power Input @ Heating (W)	733(285 ~ 1330)
MCA: Min. circuit amps (A)	MOCP: Max. over current protection (A)
RLA: Rated load amps (A)	W: Fan motor rated output (W)

PIPING

Throttle type(Indoor)	N/A
Throttle type(Outdoor)	EXV
Liquid Size	6.35mm(1/4in)
Gas Size	9.52mm(3/8in)
Max. Piping Length(ft/m)	82.00(25)
Max. Height Difference(ft/m)	49.20(15)
Max. Pre-charged Length(ft/m)	24.6(7.5)
Refrigerant Pre-charged Amount(oz/kg)	35.27(1.00)
Additional Charge of Refrigerant((oz/ft)/(g/l)	0.16(15)
Connection Method	Flared

Indoor Unit Dimension

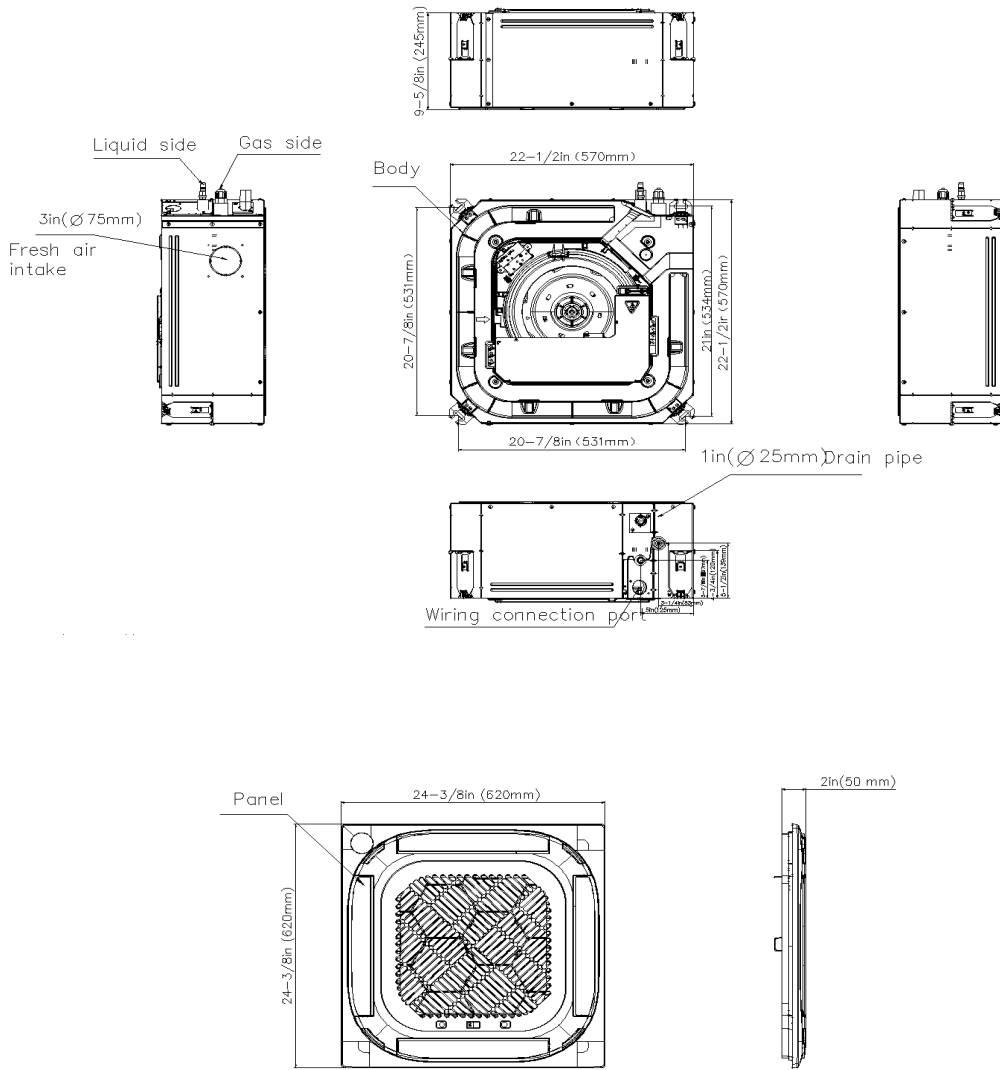

Installation Instruction

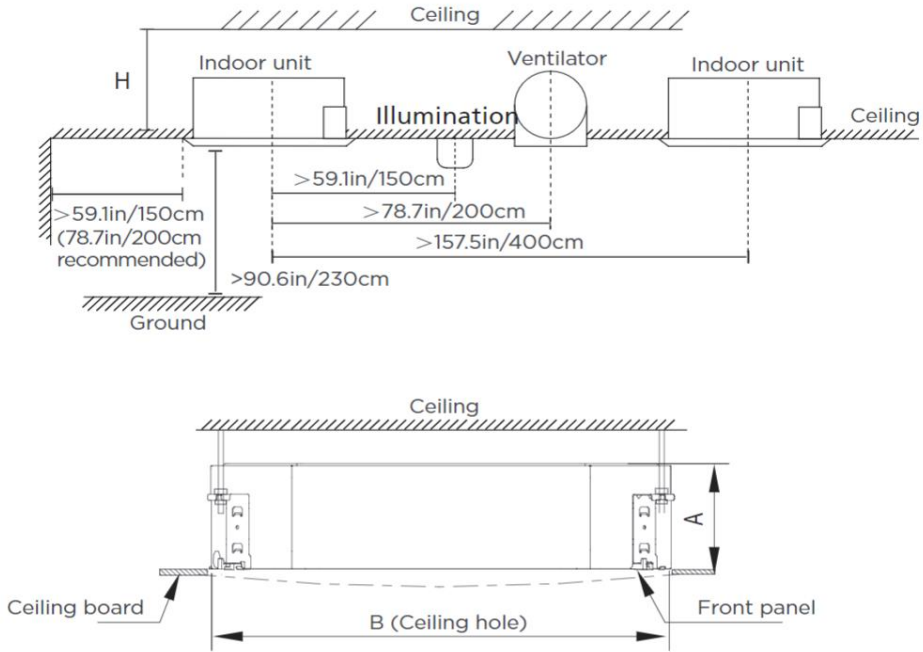

Distance from ceiling relative to height of indoor unit

MODEL	Length of A	Length of H	Length of B
9K/12K/18K	9.6in (245mm)	>10.8in (275mm)	23.6in (600mm)
24K	8.03in (205mm)	9.06in (230mm)	
36K	9.65in (245mm)	10.7in (271mm)	35.4in (900mm)
48K	11.3in (287mm)	12.3in (313mm)	

Outdoor Unit Dimension

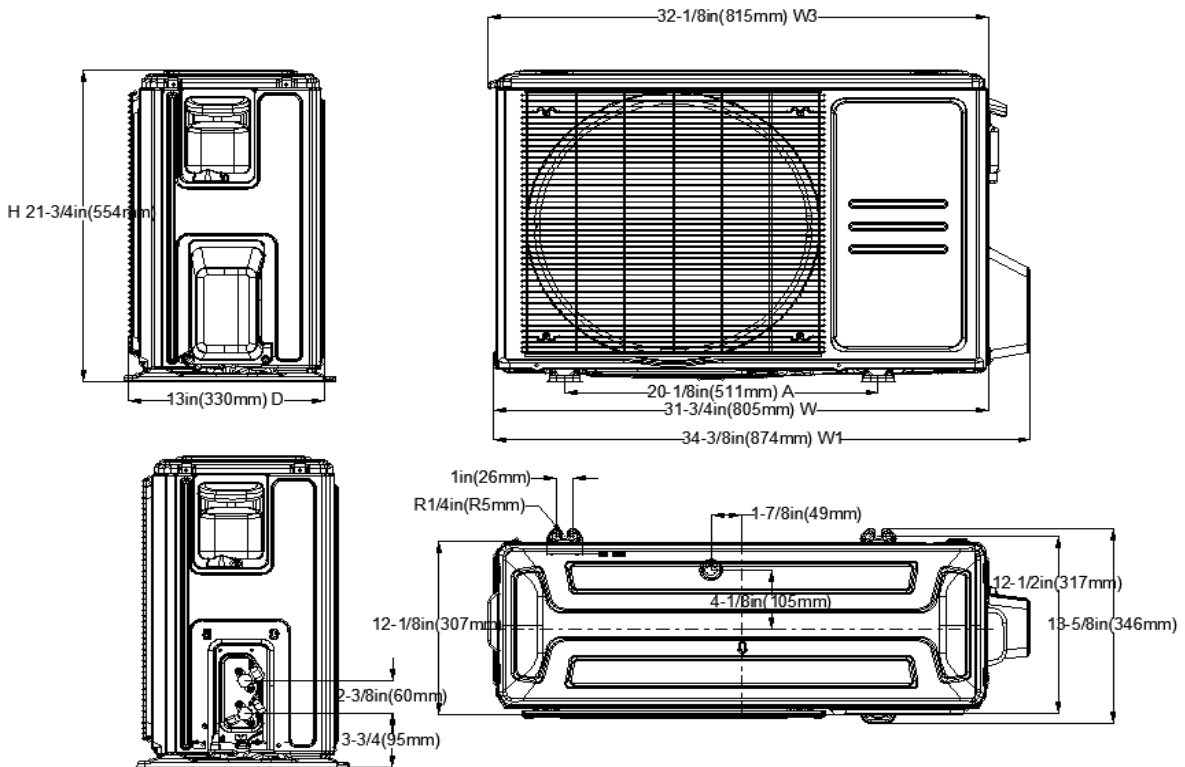

Installation Instruction

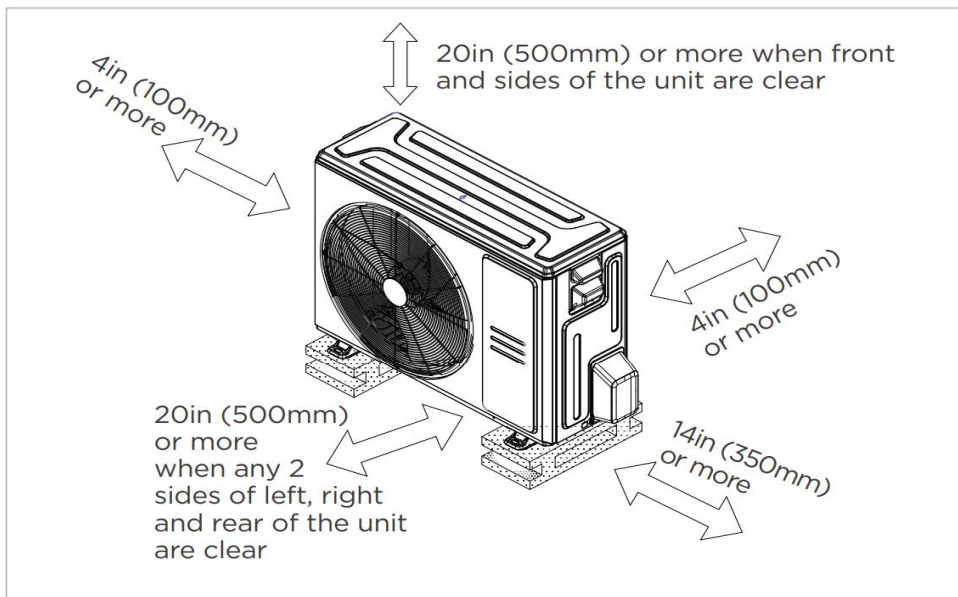

Meets all spatial requirements shown in Installation Clearance Requirements above.

FEATURES

- 360° Air Flow
- Remote on-off and alarm ports
- Refrigerant leakage detection sensor(Optional)
- Humidity sensor
- Built-in pump
- 1~100% fan speed setting
- WiFi capability: through WiFi dongle or wired controller with built-in WiFi
- OTA(by using WiFi dongle)
- 2-pin connector(HA/HB) for programmable wired controller
- Multiple control options available:
 - Two way communication wired controller with built-in WiFi:AWC-8P-LC-WIFI
 - Infrared wired controller: AWC-4
 - Wireless remote controller
 - Third-Party 24V Thermostat

*24V interface is required.