

**Air Handler Heat Pump System**

Location:	Approval:
Engineer:	Date:
Submitted to:	Construction:
Submitted by:	Unit #:
Reference:	Drawing #:



**INDOOR SPECIFICATION**

ESP(in.W.G)	0-0.8
Indoor Air Flow (Turbo/H/M/L/Si) (CFM)	824.0 / 759.3 / 694.5 / 629.8 / N/A
Indoor Noise Level (Turbo/H/M/L/Si) (dBA)	N/A/44/42/28/N/A
Dimension (W×D×H)	inch 21.02 x 17.52 x 45.00
	mm 534.0×445.0×1143.0
Package (W×D×H)	inch 26.57 x 20.87 x 48.62
	mm 675×530×1235
Net/Gross Weight	lbs 105.60/127.43
	kg 47.9/57.8

**OUTDOOR SPECIFICATION**

Compressor Type	ROTARY
Compressor Model	KTM240D46UKT2
Refrigerant	R454B
Refrigerant Oil Charge(mL)	620
Refrigerant Oil	VG74
Outdoor Air Flow (Max) (CFM)	1765.7
Outdoor Noise Level (dBA)	60
Dimension (W×D×H)	inch 35.04 x 13.46 x 26.50
	mm 890.0×342.0×673.0
Package (W×D×H)	inch 39.17 x 15.67 x 29.13
	mm 995×398×740
Net/Gross Weight	lbs 102.29/109.13
	kg 46.4/49.5

**EFFICIENCY**

Cooling		Heating	
SEER2	18.3	HSPF2-4	10.0
EER2	11.7	COP	3.33

**PERFORMANCE of Cooling**

**Cooling (Btu/hr)**

Rated Capacity	23000
Min/Max Capacity	7200~27000
Moisture Removal(L/h)	2.05
Standard Operating Range(°F/°C)	-22~122(-30~50)
Rated Cooling Conditions:	Indoor: 80°F DB/67°F WB Outdoor: 95°F DB/75°F WB

**PERFORMANCE of Heating**

**Heating (Btu/hr)**

1. @ 47°F Rated	24000
2. @ 47°F Min/Max Capacity	7100~30000
3. @ 17°F Rated	20000
4. @ 5°F Rated: Capacity / COP	21600/1.87
5. @ 5°F Max: Capacity	21600
Standard Operating Range(°F/°C)	-22~75(-30~24)
1. Rated Heating Conditions:	Indoor: 70°F DB/60°F WB Outdoor: 47°F DB/43°F WB
2. Rated Heating Conditions:	Indoor: 70°F DB/60°F WB Outdoor: 17°F DB/15°F WB
3. Heating Conditions, Compressor Operating at Max. Frequency	Indoor: 70°F DB/60°F WB Outdoor: 5°F DB/5°F WB

**ELECTRICAL**

Indoor Power Supply	115/208/230V,60Hz,1Ph
Indoor MCA 115V/(208/230V)	5.5/4.0
Indoor MOP	15
Outdoor Power Supply	208/230V,60Hz,1Ph
Outdoor MCA	19
Outdoor MOP	20
Communication Wiring	AWG 20-2
Compressor RLA	14
Outdoor Fan Motor RLA	1
Outdoor Fan Motor W	80
Indoor Fan Motor RLA	3
Indoor Fan Motor W	250
System Power Input @ Cooling (W)	1965(530 ~ 2870)
System Power Input @ Heating (W)	2112(440 ~2730)
MCA: Min. circuit amps (A)	MOCP: Max. over current protection (A)
RLA: Rated load amps (A)	W: Fan motor rated output (W)

**PIPING**

Throttle type(Indoor)	EXV
Throttle type(Outdoor)	EXV
Liquid Size	9.52mm(3/8in)
Gas Size	19mm(3/4in)
Max. Piping Length(ft/m)	164(50)
Max. Height Difference(ft/m)	82(25)
Max. Pre-charged Length(ft/m)	24.6(7.5)
Refrigerant Pre-charged Amount(oz/kg)	74.08(2.1)
Additional Charge of Refrigerant((oz/ft)/(g/m))	0.7(65)
Connection Method	Flared

## Indoor Unit Dimension

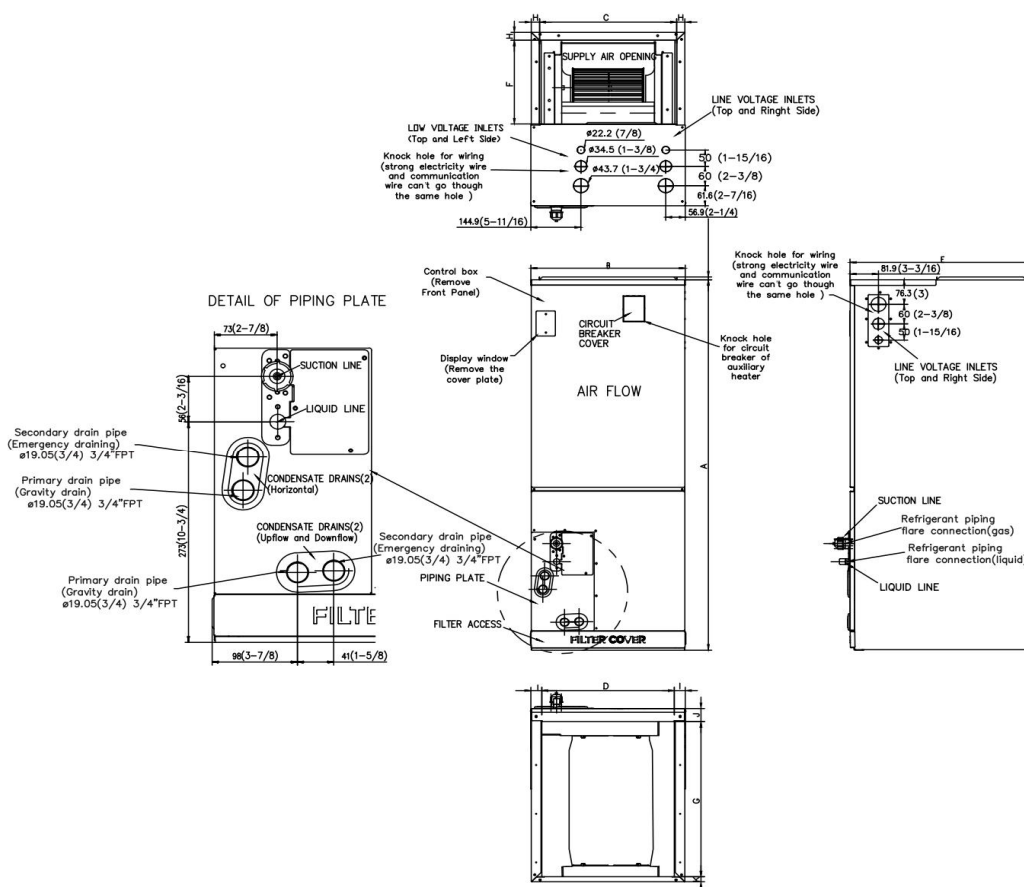

Dimensions	Model	18k/24k		30k/36k		48k/60k	
		inch	mm	inch	mm	inch	mm
A	Model Height	45	1143	49	1245	53	1346
B	Model Width	17-1/2	445	21	534	24-1/2	622
C	Supply Air Opening Width	15-5/8	397	19-1/8	486	22-5/8	575
D	Return Air Opening Width	15-1/8	384	18-5/8	473	22-1/8	562
E	Model Depth	21	534	21	534	21	534
F	Supply Air Opening Depth	10-1/4	260	10-1/4	260	10-1/4	260
G	Return Air Opening Depth	18-3/4	476	18-3/4	476	18-3/4	476
H	Supply Air Opening Clearance	15/16	24	15/16	24	15/16	24
I	Return Air Opening Side Clearance	1-1/4	32	1-1/4	32	1-1/8	28
J	Return Air Opening Front Clearance	1-1/2	38	1-5/8	41	1-5/8	41
K	Return Air Opening Back Clearance	5/8	16	5/8	16	3/4	19

### Outdoor Unit Dimension

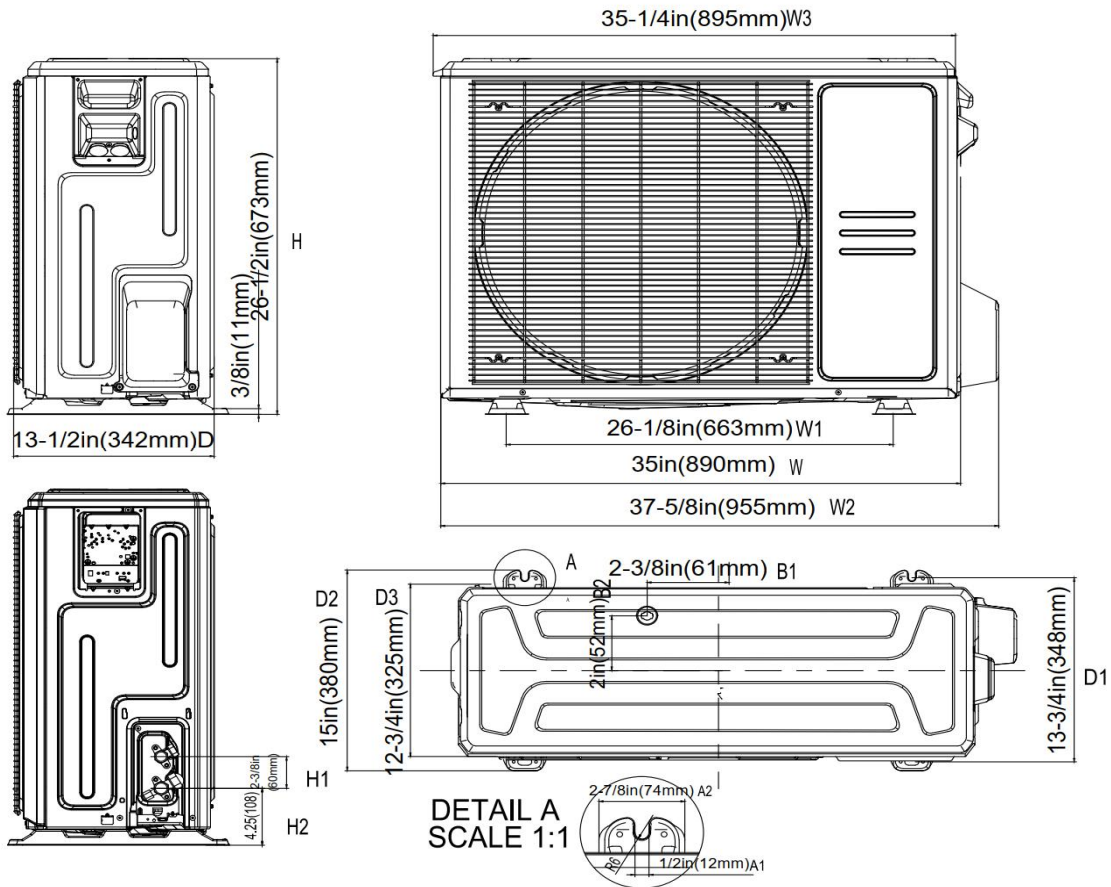

### Installation Instruction For Outdoor Unit

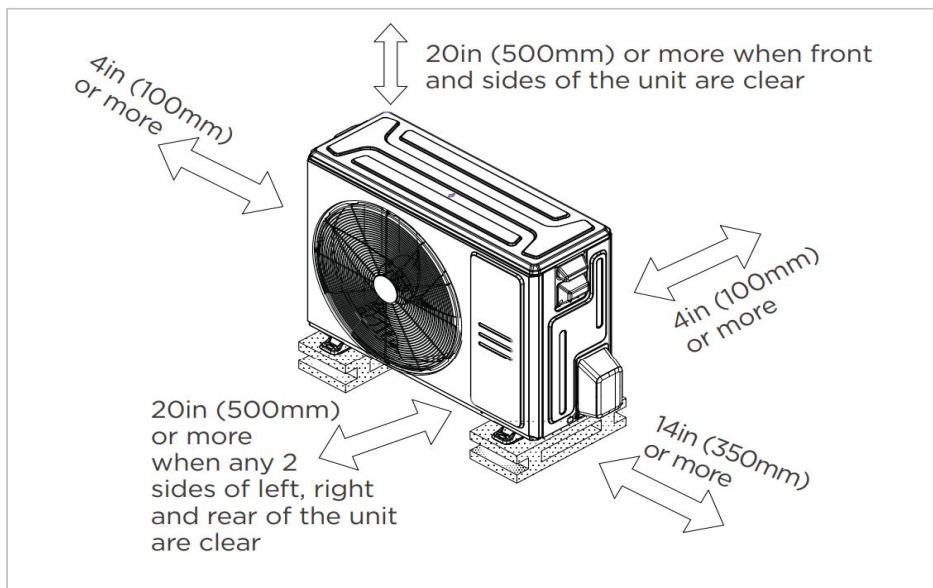

Meets all spatial requirements shown in Installation Clearance Requirements above.

### Fan Performance For Indoor Unit

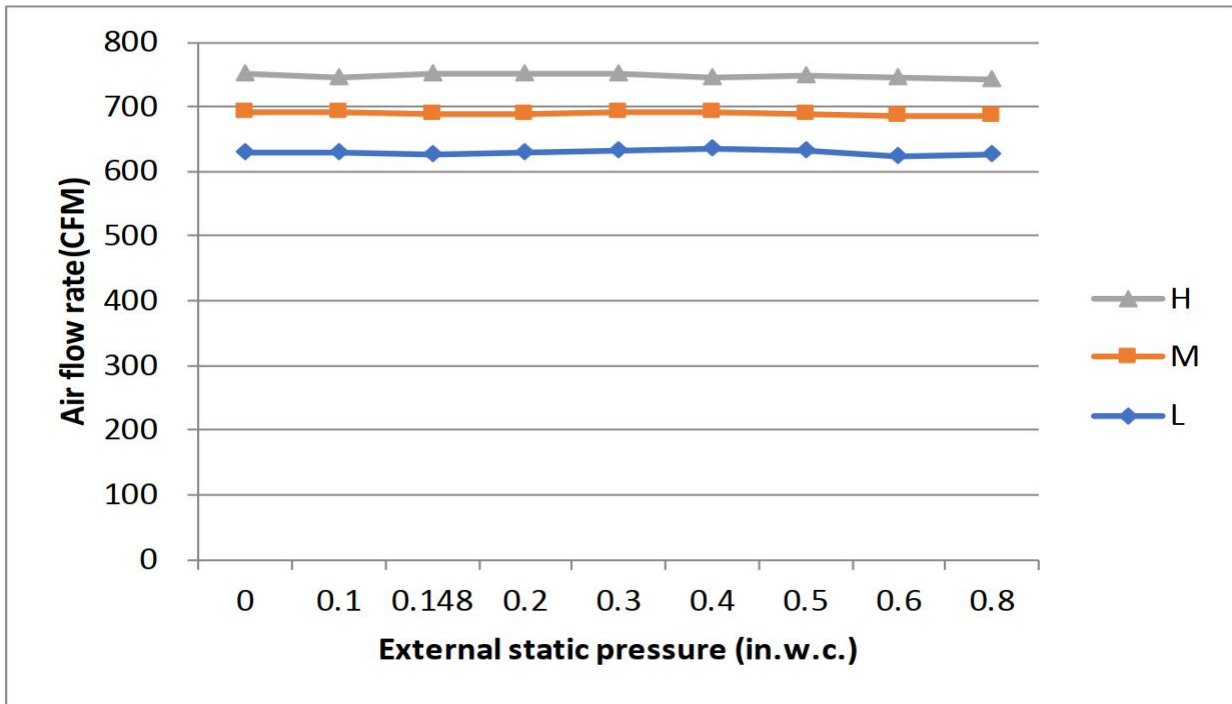

### Features

- Multi-position installation: horizontal(left or right), vertical( up or down)
- Aluminum Coil
- Constantly Air Flow system up to 0.80 In.W.G
- 1 inch R4.2 fiberglass free insulation reduces condensation and boosts efficiency(optional)
- Optional Auxiliary heat kit up to 25kW
- Easy Maintenance
- Multiple control options available:
  - Two way communication wired controller with built-in WiFi:AWC-8P-LC-WIFI
  - Wireless remote controller
  - Third-Party 24V Thermostat
- Adaptive Control System
- High efficiency up to 19 SEER2, 12.5 EER2, 10.3 HSPF2
- 100% heat output at -4F\*
- Chassis heater and crankcase heater equipped as standard

\* For 36K model, rated cooling capacity/heating capacity at -4F=100%