

**Air Handler Heat Pump System**

Location:	Approval:
Engineer:	Date:
Submitted to:	Construction:
Submitted by:	Unit #:
Reference:	Drawing #:



**INDOOR SPECIFICATION**

Indoor Air Flow (Turbo/H/M/L/Si) (CFM)	988.85 / 894.67 / 806.38 / 712.21 / N/A		
Indoor Noise Level (Turbo/H/M/L/Si) (dBA)	N/A/46/42/29/N/A		
Dimension (W×D×H)	inch	21.02 x 21.02 x 49.02	
	mm	534.0×534.0×1245.0	
Package (W×D×H)	inch	26.57 x 24.41 x 52.56	
	mm	675×620×1335	
Net/Gross Weight	lbs	128.97/153.44	
	kg	58.5/69.6	

**OUTDOOR SPECIFICATION**

Compressor Type	ROTARY		
Compressor Model	KTF250D22UMT		
Refrigerant	R454B		
Refrigerant Oil Charge(mL)	670		
Refrigerant Oil	VG74		
Outdoor Air Flow (Max) (CFM)	3001.8		
Outdoor Noise Level (dBA)	60		
Dimension (W×D×H)	inch	37.24 x 16.14 x 31.89	
	mm	946.0×410.0×810.0	
Package (W×D×H)	inch	42.91 x 19.68 x 34.84	
	mm	1090×500×885	
Net/Gross Weight	lbs	141.76/152.34	
	kg	64.3/69.1	

**EFFICIENCY**

Cooling		Heating	
SEER2	17.0	HSPF2-4	8.5
EER2	10.7	COP	3.50

**PERFORMANCE of Cooling**

Cooling (Btu/hr)	
Rated Capacity	30000
Min/Max Capacity	10400~34000
Moisture Removal(L/h)	3.57
Standard Operating Range(°F/°C)	-13~122(-25~50)
Rated Cooling Conditions:	Indoor: 80°F DB/67°F WB Outdoor: 95°F DB/75°F WB

**PERFORMANCE of Heating**

Heating (Btu/hr)	
1. @ 47°F Rated	31000
2. @ 47°F Min/Max Capacity	6400~32000
3. @ 17°F Rated	18500
4. @ 5°F Rated: Capacity / COP	19100/2
5. @ 5°F Max: Capacity	19100
Standard Operating Range(°F/°C)	-13~75(-25~24)
1. Rated Heating Conditions:	Indoor: 70°F DB/60°F WB Outdoor: 47°F DB/43°F WB
2. Rated Heating Conditions:	Indoor: 70°F DB/60°F WB Outdoor: 17°F DB/15°F WB
3. Heating Conditions, Compressor Operating at Max. Frequency	Indoor: 70°F DB/60°F WB Outdoor: 5°F DB/5°F WB

**ELECTRICAL**

Indoor Power Supply	115/208/230V,60Hz,1Ph	
Indoor MCA 115V/(208/230V)	8.0/6.0	
Indoor MOP	15	
Outdoor Power Supply	208/230V,60Hz,1Ph	
Outdoor MCA	22.5	
Outdoor MOP	25	
Communication Wiring	AWG 20-2	
Compressor RLA	17	
Indoor Fan Motor RLA	1.1	
Outdoor Fan Motor W	120	
Indoor Fan Motor RLA	4.5	
Indoor Fan Motor W	375	
System Power Input @ Cooling (W)	2778(735 ~ 3230)	
System Power Input @ Heating (W)	2595(455 ~2550)	
MCA: Min. circuit amps (A)	MOCP: Max. over current protection (A)	
RLA: Rated load amps (A)	W: Fan motor rated output (W)	

**PIPING**

Throttle type(Indoor)	EXV
Throttle type(Outdoor)	EXV
Liquid Size	9.52mm(3/8in)
Gas Size	19mm(3/4in)
Max. Piping Length(ft/m)	164(50)
Max. Height Difference(ft/m)	82(25)
Max. Pre-charged Length(ft/m)	24.6(7.5)
Refrigerant Pre-charged Amount(oz/kg)	91.71(2.6)
Additional Charge of Refrigerant((oz/ft)/(g/m))	0.7(65)
Connection Method	Flared

## Indoor Unit Dimension

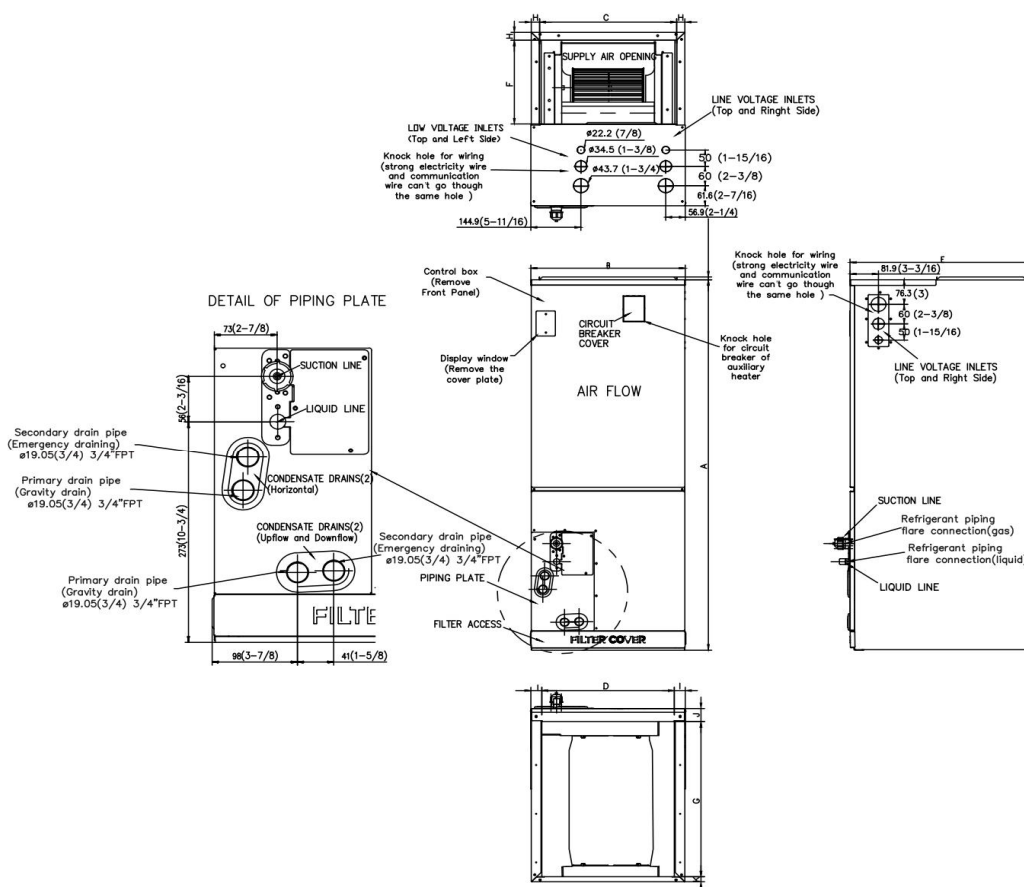

Dimensions	Model	18k/24k		30k/36k		48k/60k	
		inch	mm	inch	mm	inch	mm
A	Model Height	45	1143	49	1245	53	1346
B	Model Width	17-1/2	445	21	534	24-1/2	622
C	Supply Air Opening Width	15-5/8	397	19-1/8	486	22-5/8	575
D	Return Air Opening Width	15-1/8	384	18-5/8	473	22-1/8	562
E	Model Depth	21	534	21	534	21	534
F	Supply Air Opening Depth	10-1/4	260	10-1/4	260	10-1/4	260
G	Return Air Opening Depth	18-3/4	476	18-3/4	476	18-3/4	476
H	Supply Air Opening Clearance	15/16	24	15/16	24	15/16	24
I	Return Air Opening Side Clearance	1-1/4	32	1-1/4	32	1-1/8	28
J	Return Air Opening Front Clearance	1-1/2	38	1-5/8	41	1-5/8	41
K	Return Air Opening Back Clearance	5/8	16	5/8	16	3/4	19

### Outdoor Unit Dimension

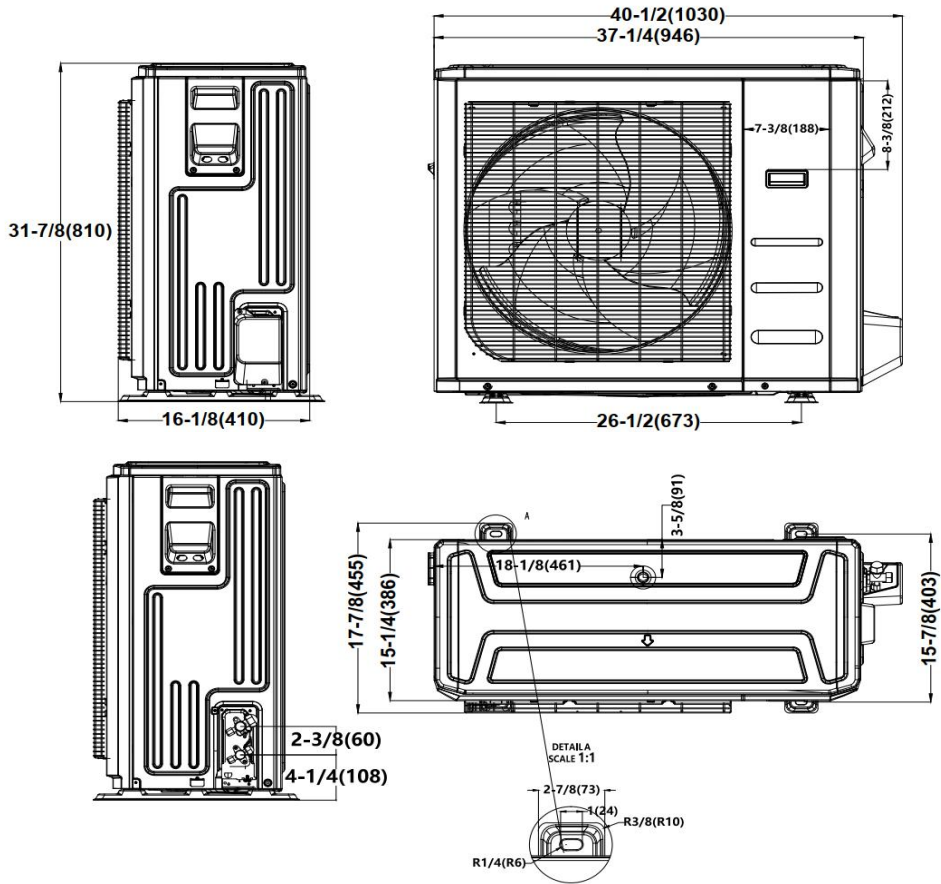

### Installation Instruction For Outdoor Unit

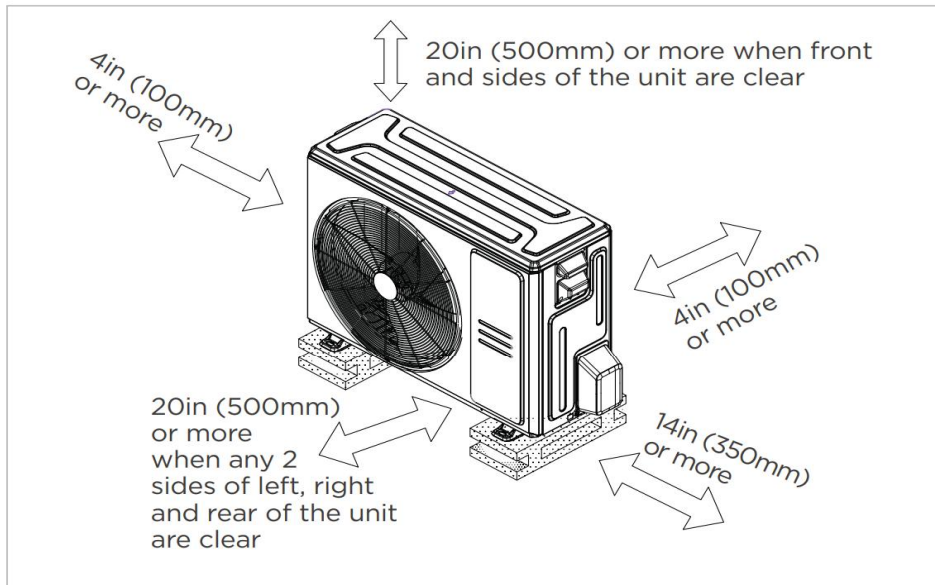

Meets all spatial requirements shown in Installation Clearance Requirements above.

## Fan Performance For Indoor Unit

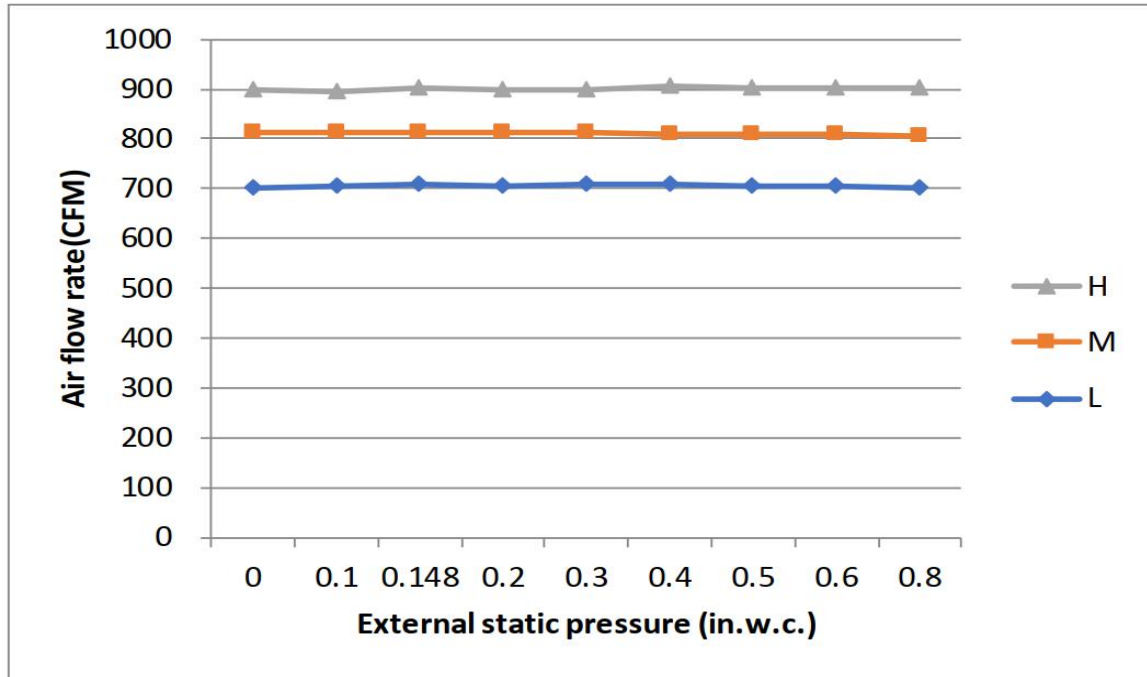

## Features

- Multi-position installation: horizontal(left or right), vertical( up or down)
- Aluminum Coil
- Constantly Air Flow system up to 0.80 In.W.G
- 1 inch R4.2 fiberglass free insulation reduces condensation and boosts efficiency(optional)
- Optional Auxiliary heat kit up to 25kW
- Easy Maintenance
- Multiple control options available:
  - Two way communication wired controller with built-in WiFi:AWC-8P-LC-WIFI
  - Wireless remote controller
  - Third-Party 24V Thermostat
- Adaptive Control System
- High efficiency up to 18.8 SEER2, 11 EER2, 9.7 HSPF2
- Chassis heater and crankcase heater equipped as standard