

# Submittal

TAG: \_\_\_\_\_

PRODUCT NAME \_\_\_\_\_  
LOCATION \_\_\_\_\_  
ARCHITECT \_\_\_\_\_  
ENGINEER \_\_\_\_\_  
CONTRACTOR \_\_\_\_\_  
SUBMITTED BY \_\_\_\_\_ DATA \_\_\_\_\_

## UNIT SUMMARY

Quantity						
Unit Designation						
Model No.						
Cooling Input						
Cooling Output						
CFM/ESP						
COP/HSPF						
Electrical						
Minimum Ampacity						
Max Overcurrent Protection						
Net Unit Weight						
Accessory						
Catalog Form Number						

### ACCESSORIES

### NOTES

# Condensing Unit

## BAH6 Series Air Conditioner

Up to 14.3 SEER2

Cooling & Heating capacity: 42 kBTU/h

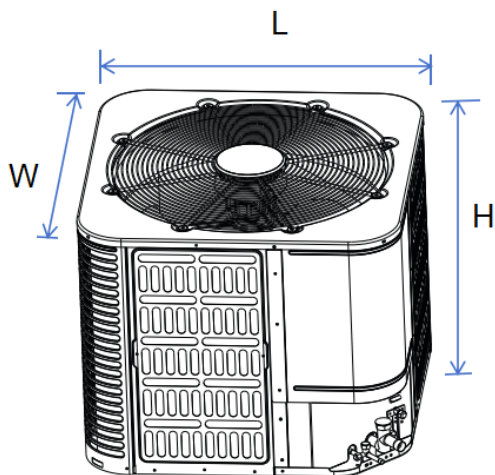

Model Size	Unit Width "W" in. [mm]	Unit Height "H" in. [mm]	Unit Length "L" in. [mm]	Packing (W*H*D) in. [mm]	Unit Weight (lbs.[kg])
18	21-4/5 [551]	25 [633]	21-4/5 [551]	22-3/5×25-9/10×22-3/5[575 × 660 × 575]	132 [60]
24	21-4/5 [551]	25 [633]	21-4/5 [551]	22-3/5×25-9/10×22-3/5[575 × 660 × 575]	133 [60.5]
30	29-1/7 [740]	25 [633]	29-1/7 [740]	29-9/10×25-9/10×29-9/10[760× 660×760]	164 [74.5]
36	29-1/7 [740]	25 [633]	29-1/7 [740]	29-9/10×25-9/10×29-9/10[760× 660×760]	168 [76]
42	29-1/7 [740]	32-7/8 [835]	29-1/7 [740]	29-9/10×34-2/5×29-9/10[760× 875× 760]	183 [83]
48	29-1/7 [740]	32-7/8 [835]	29-1/7 [740]	29-9/10×34-2/5×29-9/10[760× 875× 760]	203 [92]
60	29-1/7 [740]	32-7/8 [835]	29-1/7 [740]	29-9/10×34-2/5×29-9/10[760× 875× 760]	216 [98]

# Specifications

<b>Model</b>		<b>BAH6-42-15</b>	
<b>Outdoor power supply</b>		<b>V/Ph/Hz</b>	230V/1N/60HZ
<b>Cooling</b>	<b>Capacity</b>	<b>Btu/h</b>	41000
	<b>EER2</b>	<b>Btu/h.W</b>	11.7
	<b>SEER2</b>	<b>Btu/h.W</b>	14.3
<b>Heating</b>	<b>Capacity</b>	<b>Btu/h</b>	40600
	<b>HSPF2</b>	<b>Btu/h.W</b>	7.5
<b>Refer to Room Area</b>	<b>square feet</b>		630.00
<b>Max. input consumption</b>		<b>W</b>	/
<b>Max. current</b>		<b>A</b>	/
<b>MCA</b>		<b>A</b>	25
<b>MOP</b>		<b>A</b>	35
<b>Compressor</b>	<b>Brand</b>		LG
	<b>Model</b>		YPH036KAA
	<b>Type</b>		scroll
	<b>Capacity</b>	<b>Btu/h</b>	44700
	<b>Input</b>	<b>W</b>	2684
	<b>Rated current(RLA)</b>	<b>A</b>	12.6
	<b>Locked rotor Amp(LRA)</b>	<b>A</b>	96
<b>Outdoor fan motor</b>	<b>Brand</b>		Broad-Ocean/Panasonic
	<b>Model</b>		DRN-310-200-10
	<b>Rate current</b>	<b>A</b>	1.80
	<b>Input</b>	<b>W</b>	256.00
	<b>Output</b>	<b>W</b>	200.00
	<b>Capacitor</b>	<b>μF</b>	/
	<b>Speed</b>	<b>rpm</b>	950.00
<b>Outdoor fan blade</b>	<b>Dimension</b>	<b>mm</b>	φ595×115×φ12.7
<b>Outdoor coil</b>	<b>Number of row</b>		2.70
	<b>Fin spacing</b>	<b>in</b>	0.06
	<b>Fin material</b>		Hydrophilic Aluminium Fin
	<b>Tube outside diameter</b>	<b>in</b>	Φ 0.276
	<b>Tube material</b>		Inner Grooved
	<b>Coil length x height x width</b>	<b>in</b>	84.65×31.48×1.05
	<b>Number of circuit</b>		8.00
<b>Outdoor air flow</b>		<b>CFM</b>	3540.00
<b>Outdoor noise level</b>		<b>dB(A)</b>	60.00
<b>Throttling type</b>			Piston
<b>Outdoor dimension</b>	<b>Unit (WxHxD)</b>	<b>in</b>	29-1/7×32-7/8×29-1/7
		<b>mm</b>	740×835×740
	<b>Packing (WxHxD)</b>	<b>in</b>	29-9/10×34-2/5×29-9/10
		<b>mm</b>	760×875×760
	<b>Net / Gross weight</b>	<b>kg</b>	83/89
		<b>lbs</b>	183/196

Refrigerant	Type		R454b
	Charging	oz	137.56
Refrigerant pipe	Liquid side	in	Φ3/8
	Gas side	in	Φ3/4
	Max. refrigerant pipe length	ft	131
	Max. difference in level	ft	60
Design pressure		MPa	3.79/1.72
Max pressure		MPa	4.15
Operation temp range	Cooling	°F	53-120
	Heating	°F	5-80

**Standard Features:**

- Eco-friendly R454B refrigerant with low GWP value.
- Energy-efficient compressor.
- Equipped with thermal overload protection.
- High quality condenser with inner-groove copper tube and aluminum fin.
- Service valves with sweat connections and easy-access gauge ports.
- Factory-installed high-pressure switch.
- AHRI certified and ETL listed.
- 

**Cabinet Features:**

- Compact design allows for ease of installation, clearance, durability, and maneuverability.
- Powder-painted galvanized steel cabinet chassis.
- Protective steel louvered coil guard.
- Steel wire axial fan guard
- ECM fan motor and unique blade style allowing for smooth discharge air and quieter operation.

# ComfortStar®

---

Add.: 12201 N W 107th Avenue Miami, FL 33178

1.866.524.9898 Toll Free

305.500.9898 Office

305.500.9896 Fax document.

<http://www.comfortstarusa.com>