

Submittal

TAG: _____

PRODUCT NAME _____
LOCATION _____
ARCHITECT _____
ENGINEER _____
CONTRACTOR _____
SUBMITTED BY _____ DATA _____

UNIT SUMMARY

Quantity						
Unit Designation						
Model No.						
Cooling Input						
Cooling Output						
CFM/ESP						
COP/HSPF						
Electrical						
Minimum Ampacity						
Max Overcurrent Protection						
Net Unit Weight						
Accessory						
Catalog Form Number						

ACCESSORIES

NOTES

Condensing Unit
BAR6 Series Air Conditioner
Up to 14.3 SEER2
Cooling capacity: 30kBTU/h

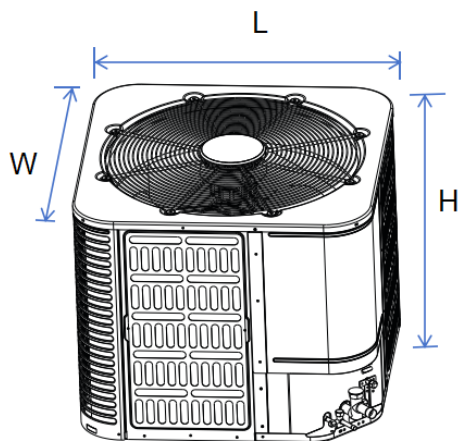

Model Size	Unit Width "W" in. [mm]	Unit Height "H" in. [mm]	Unit Length "L" in. [mm]	Packing (W*H*D) in. [mm]	Unit Weight (lbs.[kg])
18	21-4/5 [551]	25 [633]	21-4/5 [551]	22-3/5×25-9/10×22-3/5[575 × 660 × 575]	126 [57]
24	21-4/5 [551]	25 [633]	21-4/5 [551]	22-3/5×25-9/10×22-3/5[575 × 660 × 575]	127 [57.5]
30	29-1/7 [740]	25 [633]	29-1/7 [740]	29-9/10×25-9/10×29-9/10[760× 660×760]	158 [71.5]
36	29-1/7 [740]	25 [633]	29-1/7 [740]	29-9/10×25-9/10×29-9/10[760× 660×760]	160 [72.5]
42	29-1/7 [740]	32-7/8 [835]	29-1/7 [740]	29-9/10×34-2/5×29-9/10[760× 875× 760]	176 [80]
48	29-1/7 [740]	32-7/8 [835]	29-1/7 [740]	29-9/10×34-2/5×29-9/10[760× 875× 760]	196 [89]
60	29-1/7 [740]	32-7/8 [835]	29-1/7 [740]	29-9/10×34-2/5×29-9/10[760× 875× 760]	207 [94]

Specifications

Model		BAR6-30-15	
Outdoor power supply		V/Ph/Hz	230V/1N/60HZ
Cooling	Capacity	Btu/h	28000
	EER2	Btu/h.W	11.7
	SEER2	Btu/h.W	14.3
Refer to Room Area	square feet		441.00
Max. input consumption		W	/
Max. current		A	/
MCA		A	15
MOP		A	20
Compressor	Brand		LG
	Model		YPH024KAA
	Type		scroll
	Capacity	Btu/h	29700.00
	Input	W	1772.00
	Rated current(RLA)	A	10.10
	Locked rotor Amp(LRA)	A	71.00
Outdoor fan motor	Brand		Broad-Ocean
	Model		DRN-310-200-10
	Rate current	A	1.30
	Input	W	226
	Output	W	200
	Capacitor	μF	/
	Speed	rpm	950
Outdoor fan blade	Dimension	mm	Φ585×110×Φ12.7
Outdoor coil	Number of row		2
	Fin spacing	in	0.055
	Fin material		Hydrophilic Aluminium Fin
	Tube outside diameter	in	Φ 0.276
	Tube material		Inner Grooved
	Coil length x height x width	in	84.09×23.15×1.05
	Number of circuit		6
Outdoor air flow		CFM	3350
Outdoor noise level		dB(A)	60
Throttling type			Piston
Outdoor dimension	Unit (WxHxD)	in	29-1/7×25×29-1/7
		mm	740×633×740
	Packing (WxHxD)	in	30-1/2×26-3/4×x30-1/2
		mm	775×680×775
	Net / Gross weight	kg	71.5/76
		lbs	158/168
Refrigerant	Type		R454b
	Charging	oz	116.40

Refrigerant pipe	Liquid side	in	Φ3/8
	Gas side	in	Φ3/4
	Max. refrigerant pipe length	ft	131
	Max. difference in level	ft	60
Design pressure		MPa	3.79/1.72
Max pressure		MPa	4.15
Operation temp range	Cooling	°F	53-120

Standard Features:

- Eco-friendly R454B refrigerant with low GWP value.
- Energy-efficient compressor.
- Equipped with thermal overload protection.
- High quality condenser with inner-groove copper tube and aluminum fin.
- Service valves with sweat connections and easy-access gauge ports.
- Factory-installed high-pressure switch.
- AHRI certified and ETL listed.

Cabinet Features:

- Compact design allows for ease of installation, clearance, durability, and maneuverability.
- Powder-painted galvanized steel cabinet chassis.
- Protective steel louvered coil guard.
- Steel wire axial fan guard
- ECM fan motor and unique blade style allowing for smooth discharge air and quieter operation.

ComfortStar®

Add.: 12201 N W 107th Avenue Miami, FL 33178

1.866.524.9898 Toll Free

305.500.9898 Office

305.500.9896 Fax document.

<http://www.comfortstarusa.com>