

SUBMITTAL DATA SHEET



CAC12CD-WI

Location: _____
 Engineer: _____
 Submitted to: _____
 Submitted by: _____
 Reference: _____

Approval: _____
 Date: _____
 Construction: _____
 Unit #: _____
 Drawing #: _____

Set Model

Indoor unit model CAC12CD(I)-WI
 Outdoor unit model CAC12CD(O)-WI

Certified



SYSTEM PERFORMANCE DATA

Power supply	V-Ph-Hz	220_230V_1Ph, 60HZ
Cooling Capacity	Btu/h	12000
Input	W	1060
Current	A	4.7
EER	W/W	3.29
SEER	Btu/W	21.0
Rated Power Input	W	2160
Rated Current	A	10

INDOOR UNIT DATA

Indoor fan motor		
Model		ZKFP-30-8-357L
Input	W	/
Capacitor	uF	/
Speed(Hi/Mi/Lo)	r/min	1200/1040/960
Indoor air flow (Hi/Mi/Lo)	m3/h	650/550/500
	CFM	382/324/294
Indoor noise level (Hi/Mi/Lo)	dB(A)	43/38/36
Indoor unit Dimension(W*D*H)	mm	802x200x295
	inch	31.6x7.9x11.6
Indoor unit Packing (W*D*H)	mm	875x285x380
	inch	34.4x11.2x15.0
Indoor unit Net/Gross weight	kg	8.2/10.7
	lbs	18.1/23.6

REFRIGERANT PIPE DATA

Compressor

Model		KSK103D32UEZ31
Type		ROTARY
Brand		GMCC
Capacity	W	2020/3245 ±3%
Input	W	332/850 ±3%
Rated current(RLA)	A	2.42/5.70 ±3%
Refrigerant oil/oil charge	ml	ESTER OIL VG74 280 ±10

Refrigerant piping

Liquid side/ Gas side	mm(inch)	6.35mm(1/4in)/9.52mm(3/8in)
Max. refrigerant pipe length	m	25
	inch	984
Max. difference in level	m	10
	inch	394
Connection wiring		16#x4
Operation temperature	°C	17~30
	°F	63~86
Indoor temperature	°C	16~32
	°F	63~90
Outdoor temperature	°C	0~50
	°F	34~122
Application area (Cooling Standar	m ²	15~22
	ft ²	161.4~236.7

OUTDOOR UNIT DATA

Outdoor fan motor

Model		ZKFN-25-10-5L
Input	W	/
Capacitor	uF	/
Speed	r/min	850/600
Outdoor air flow	m3/h	1800
	CFM	1059
Outdoor noise level	dB(A)	54
Outdoor unit Dimension(W*D*H)	mm	720x270x495
	inch	28.3x10.6x19.5
Outdoor unit Packing (W*D*H)	mm	835x300x540
	inch	32.9x11.8x21.3
Outdoor unit Net/Gross weight	kg	19.3/21.2
	lbs	42.6/46.7

Indoor unit dimension

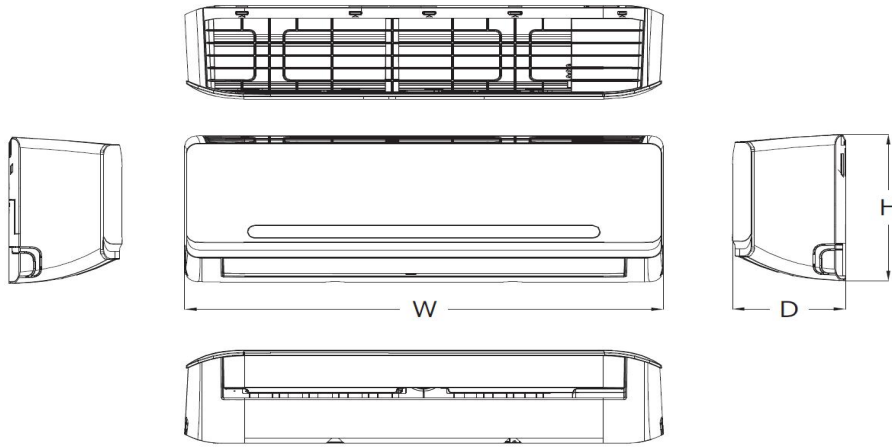

(The figure is for reference only)

Dimension(inch)	W	D	H
CAC12CA(I)-WI	31.6	7.9	11.6
CAC12CD(I)-WI	31.6	7.9	11.6
CAC18CD(I)-WI	38.2	9.0	12.6
CAC24CD(I)-WI	42.6	9.2	13.3

Outdoor unit dimension

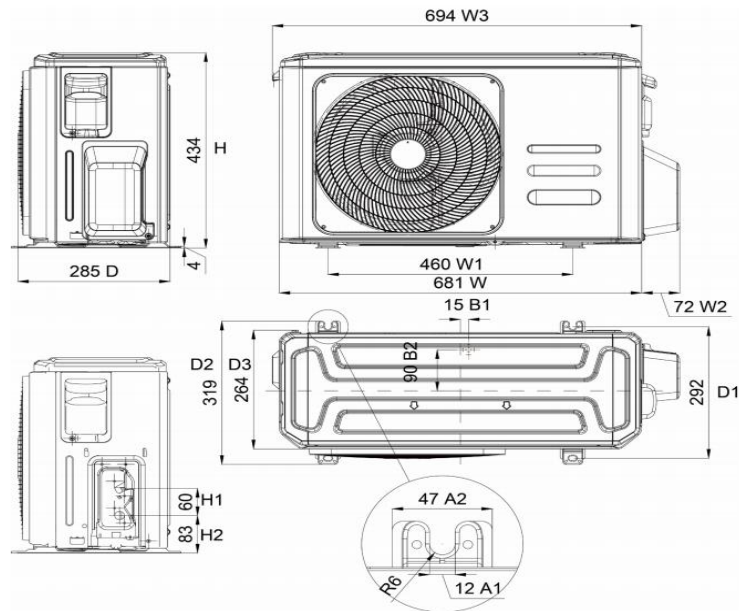

(The figure is for reference only)

Dimension(inch)	W	D	H
CAC12CA(O)-WI	28.3	10.6	19.5
CAC12CD(O)-WI	28.3	10.6	19.5
CAC18CD(O)-WI	30.1	11.9	21.9
CAC24CD(O)-WI	31.7	13.0	21.8