

# Submittal

TAG: \_\_\_\_\_

PRODUCT NAME \_\_\_\_\_  
LOCATION \_\_\_\_\_  
ARCHITECT \_\_\_\_\_  
ENGINEER \_\_\_\_\_  
CONTRACTOR \_\_\_\_\_  
SUBMITTED BY \_\_\_\_\_ DATA \_\_\_\_\_

## UNIT SUMMARY

Quantity						
Unit Designation						
Model No.						
Cooling Input						
Cooling Output						
CFM/ESP						
Electrical						
Minimum Ampacity						
Max Overcurrent Protection						
Net Unit Weight						
Accessory						
Catalog Form Number						

### ACCESSORIES

### NOTES

# Wall-Mounted CWM7(E) Series

Cooling capacity: 18 kBTU/h

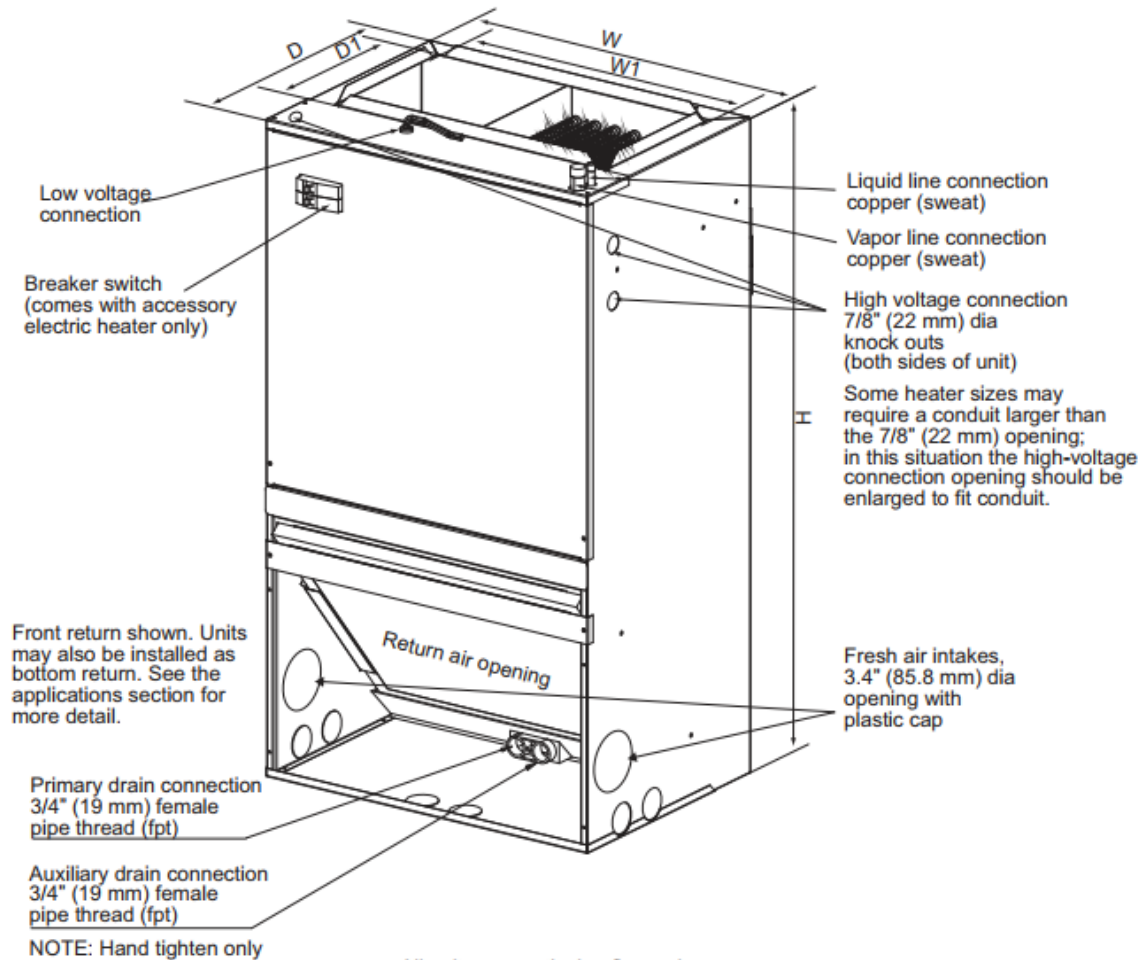

All units are vertical upflow only.  
Equipment shown with field-installed electric heat.

Model Size	Dimensions- (in.) [mm]					Unit Weight (Lbs.) [kg]
	Height H	Width W	Width W1	Depth D	Depth D1	
PSC 18K/24K	36-1/2 [928]	20-1/2 [521]	17-2/5 [442]	15 [381]	9-1/2 [242]	88 [40]
PSC 30K/36K	39-1/2 [1004]	22 [559]	18-4/5 [478]	19 [483]	9-1/2 [242]	106 [48]
ECM 18K/24K	36-1/2 [928]	20-1/2 [521]	17-2/5 [442]	15 [381]	9-1/2 [242]	84 [38]
ECM 30K/36K	39-1/2 [1004]	22 [559]	18-4/5 [478]	19 [483]	9-1/2 [242]	99 [45]

# Specifications

	<b>CWM7-18E-15</b>
<b>NOMINAL RATING</b>	
Cooling (BTU/h)	18,000
External Static Pressure (in.w.c)	0.6
<b>ELECTRICAL DATA</b>	
Voltage / Phase (60Hz)	208/230V-1Ph
Min. / Max. Voltage (V)	208/230V
Min. Circuit Amps (MCA) (A)	2.4
Max. Overcurrent Protection (MOP) (A)	15
<b>FAN MOTOR</b>	
Motor Type	ECM
Capacitor (uF)	/
Horsepower (HP)	1/3
Rated RPM	650
Full Load Amps (FLA) (A)	1.9
<b>Refrigerant Detector</b>	
Number of Detector	1
Type	TC/NDIR
Detection Threshold Limit Value (DTLV)	0.1
Measurement Range	0 ~ 100%
Operating temp (°F)	-22 ~ 158
<b>FAN BLOWER</b>	
Material	Metal
Type	Centrifugal
Diameter (in.)	10
Height (in.)	6
<b>EVAPORATOR COIL</b>	
Type	Tube & Fin
Tube Material	Aluminum
Tube Size (mm)	7
<b>Sound Pressure Level dBA</b>	49
<b>REFRIGERANT CONNECTION SIZE</b>	
Liquid Line Size (O.D.) (in.)	3/8
Suction Line Size (O.D.) (in.)	3/4

# Airflow Data

ECM Model	BLOW ER SPEEDS	EXTERNAL STATIC PRESSURE (in.w.c.)								
		0	0.1	0.2	0.3	0.4	0.5	0.6	0.7	0.8
18 (1-1/2)	Tap (1)	584	541	487	441	416	357	359	299	253
	Tap (2)	662	615	582	542	514	467	427	385	351
	Tap (3) -Factory	710	683	645	619	579	535	490	458	416
	Tap (4)	803	769	742	710	675	642	609	572	534
	Tap (5)	899	871	836	810	789	758	719	689	646
24 (2)	Tap (1)	584	541	487	441	416	357	359	299	253
	Tap (2)	662	615	582	542	514	467	427	385	351
	Tap (3)	710	683	645	619	579	535	490	458	416
	Tap (4)	803	769	742	710	675	642	609	572	534
	Tap (5) -Factory	899	871	836	810	789	758	719	689	646
30 (2-1/2)	Tap (1)	1063	1012	936	898	853	823	780	740	701
	Tap (2)	1133	1080	1026	991	958	904	858	813	769
	Tap (3) -Factory	1220	1194	1111	1100	1060	1007	952	910	855
	Tap (4)	1234	1200	1146	1229	1088	1046	1004	951	917
	Tap (5)	1341	1310	1247	1225	1192	1151	1101	1077	1033
36 (3)	Tap (1)	1063	1012	936	898	853	823	780	740	701
	Tap (2)	1133	1080	1026	991	958	904	858	813	769
	Tap (3)	1220	1194	1111	1100	1060	1007	952	910	855
	Tap (4) -Factory	1234	1200	1146	1229	1088	1046	1004	951	917
	Tap (5)	1341	1310	1247	1225	1192	1151	1101	1077	1033

--- NOTES: Shaded boxes represent airflow outside the required 300-450 CFM/ton.

1. Airflow based on dry coil at 230V with no electric heat and factory-approved filter. FMA5X airflow at 208V is approximately the same as 230V because the multi-tap ECM motor is a constant torque with no drop off regardless of motor operating speed.
2. Airflow is equivalent for front or bottom return configurations.

## Electric Heater Kits

NO.	Kit	Description	Breaker	Ref. Air Handler Use
1	CHE7W-05B	5 kW heater	Max.240 V,30 A,2 P	18, 24, 30, 36
2	CHE7W-08B	7.5 kW heater	Max.240 V,50 A,2 P	18, 24, 30, 36
3	CHE7W-10B	10 kW heater	Max.240 V,60 A,2 P	18, 24, 30, 36

## Electric Heater Kit Electrical Data (ECM)

Heater Kit Model Used	Air Handler Model	Electric Heat (kW)	Min. Circuit Ampacity		Max. Fuse or Breaker (HACR) Ampacity		Fan Speed (AC/HP)				
			240 V	208 V	240 V	208 V	1	2	3	4	5
CHE7W-05B	18	5	28.5	25.0	30	30	●	●	●	●	●
CHE7W-08B		7.5	41.5	36.3	50	50	●	●	●	●	●
CHE7W-10B		10	54.5	47.6	60	60	●	●	●	●	●
CHE7W-05B	24	5	28.5	25.0	30	30	●	●	●	●	●
CHE7W-08B		7.5	41.5	36.3	50	50	●	●	●	●	●
CHE7W-10B		10	54.5	47.6	60	60	●	●	●	●	●
CHE7W-05B	30	5	28.5	25.0	30	30	●	●	●	●	●
CHE7W-08B		7.5	41.5	36.3	50	50	●	●	●	●	●
CHE7W-10B		10	54.5	47.6	60	60	●	●	●	●	●
CHE7W-05B	36	5	28.5	25.0	30	30	●	●	●	●	●
CHE7W-08B		7.5	41.5	36.3	50	50	●	●	●	●	●
CHE7W-10B		10	54.5	47.6	60	60	●	●	●	●	●

## Features

- Direct-drive, multi-speed motors allow air volume variation for heating / cooling.
  - Multi-speed ECM motor: CWM7(E) series
  - Multi-speed PSC motor: CWM7(P) series
- Thermoplastic drain pan with bottom primary and secondary drain connections.
- Built-in filter rack.
- Wall-hanging bracket included.
- Front or bottom return available.
- Optional heating elements in 5kW, 7.5kW, and 10kW.
- All-aluminum coil.
- AHRI listed and ETL listed.
- R454B refrigerant sensor is configured to ensure safe operation.
- R454B refrigerant sensor is factory-installed, more rooms are available for installation.

**ComfortStar®**

---

Add.: 12201 N W 107th Avenue Miami, FL 33178

1.866.524.9898 Toll Free

305.500.9898 Office

305.500.9896 Fax document.

<http://www.comfortstarusa.com>