

# Submittal

TAG: \_\_\_\_\_

PRODUCT NAME \_\_\_\_\_  
LOCATION \_\_\_\_\_  
ARCHITECT \_\_\_\_\_  
ENGINEER \_\_\_\_\_  
CONTRACTOR \_\_\_\_\_  
SUBMITTED BY \_\_\_\_\_ DATA \_\_\_\_\_

## UNIT SUMMARY

Quantity						
Unit Designation						
Model No.						
Cooling Input						
Cooling Output						
CFM/ESP						
Electrical						
Minimum Ampacity						
Max Overcurrent Protection						
Net Unit Weight						
Accessory						
Catalog Form Number						

### ACCESSORIES

### NOTES

# Wall-Mounted CWM7(P) Series

Cooling capacity: 36 kBTU/h

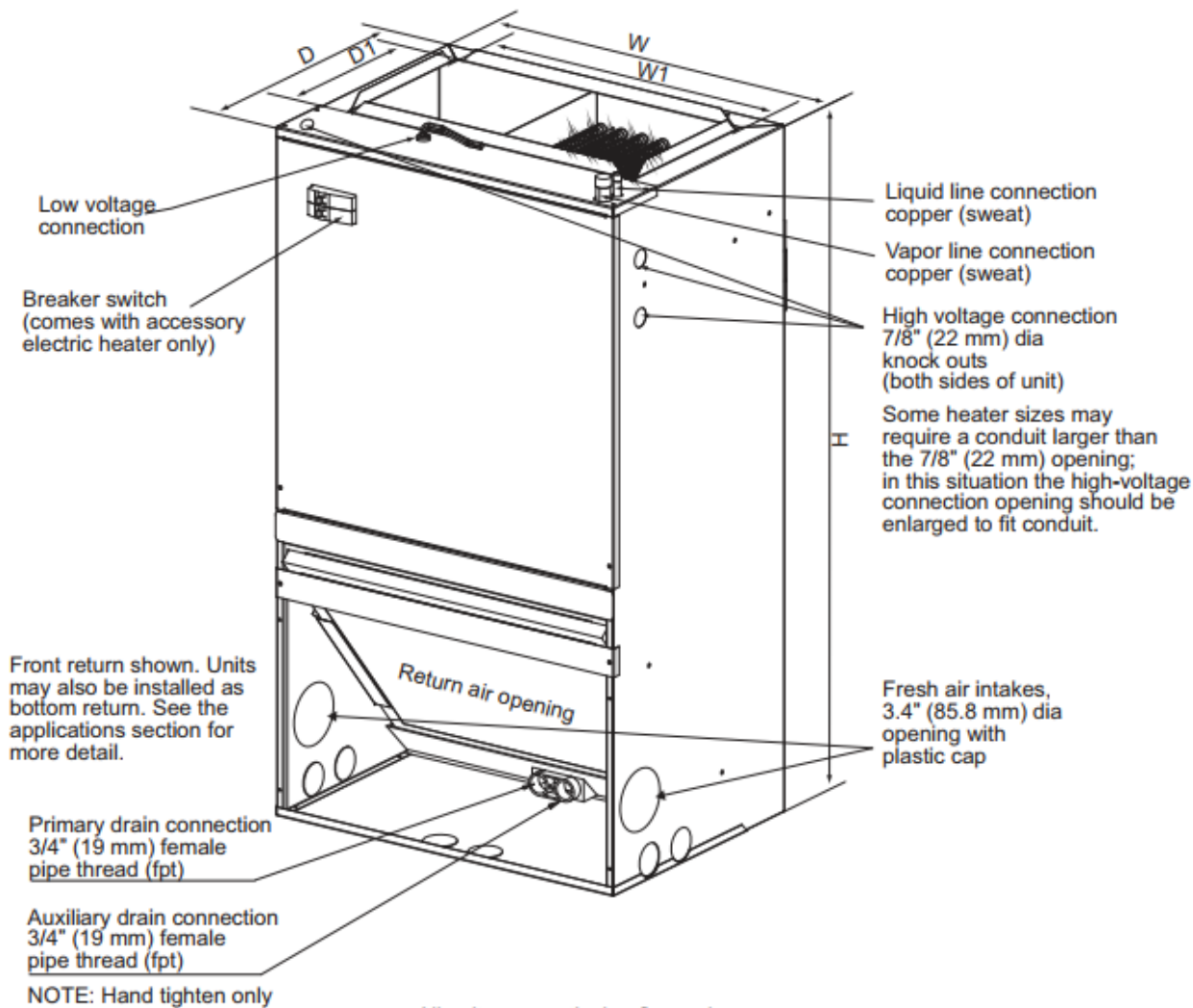

All units are vertical upflow only.  
Equipment shown with field-installed electric heat.

Model Size	Dimensions- (in.) [mm]					Unit Weight (Lbs.) [kg]
	Height H	Width W	Width W1	Depth D	Depth D1	
PSC 18K/24K	36-1/2 [928]	20-1/2 [521]	17-2/5 [442]	15 [381]	9-1/2 [242]	88 [40]
PSC 30K/36K	39-1/2 [1004]	22 [559]	18-4/5 [478]	19 [483]	9-1/2 [242]	106 [48]
ECM 18K/24K	36-1/2 [928]	20-1/2 [521]	17-2/5 [442]	15 [381]	9-1/2 [242]	84 [38]
ECM 30K/36K	39-1/2 [1004]	22 [559]	18-4/5 [478]	19 [483]	9-1/2 [242]	99 [45]

# Specifications

PSC

	<b>CWM7-36P-15</b>
<b>NOMINAL RATING</b>	
Cooling (BTU/h)	36,000
External Static Pressure (in.w.c)	0.6
<b>ELECTRICAL DATA</b>	
Voltage / Phase (60Hz)	208/230V-1Ph
Min. / Max. Voltage (V)	208/230V
Min. Circuit Amps (MCA) (A)	2.8
Max. Overcurrent Protection (MOP) (A)	15
<b>FAN MOTOR</b>	
Motor Type	PSC
Capacitor (uF)	10
Horsepower (HP)	1/3
Rated RPM	1150
Full Load Amps (FLA) (A)	2.2
<b>Refrigerant Detector</b>	
Number of Detector	1
Type	TC/NDIR
Detection Threshold Limit Value (DTLV)	0.1
Measurement Range	0 ~ 100%
Operating temp (°F)	-22 ~ 158
<b>FAN BLOWER</b>	
Material	Metal
Type	Centrifugal
Diameter (in.)	10
Height (in.)	9
<b>EVAPORATOR COIL</b>	
Type	Tube & Fin
Tube Material	Aluminum
Tube Size (mm)	7
<b>Sound Pressure Level dBA</b>	54
<b>REFRIGERANT CONNECTION SIZE</b>	
Liquid Line Size (O.D.) (in.)	3/8
Suction Line Size (O.D.) (in.)	3/4

# Airflow Data

PSC MODEL	BLOWER SPEEDS	EXTERNAL STATIC PRESSURE (in.w.c.)								
		0	0.1	0.2	0.3	0.4	0.5	0.6	0.7	0.8
18 (1-1/2)	Low	604	562	527	485	441	387	-	-	-
	Med	697	655	619	577	533	479	426	380	
	High-Factory	802	761	721	682	637	592	541	481	408
24 (2)	Low	665	629	589	547	508	480	-	-	-
	Med	831	786	741	696	655	609	559	497	-
	High-Factory	932	881	833	786	742	689	636	574	515
30 (2-1/2)	Low	988	948	900	862	816	772	719	642	613
	Med-Factory	1197	1152	1097	1046	998	940	886	821	737
	High	1338	1284	1220	1159	1096	1029	960	879	792
36 (3)	Low	1118	1072	1018	971	920	876	819	759	693
	Med	1262	1213	1160	1098	1049	998	937	871	804
	High-Factory	1360	1311	1263	1229	1166	1074	1005	934	867

--- NOTES: Shaded boxes represent airflow outside the required 300-450 CFM/ton.

1. Airflow data includes electric heat and filter.

2. Airflow data is with no return grill. When using a return grill on 18 & 24 sizes, decrease numbers above by approx. 10 CFM. For 30 &

36 sizes, decrease numbers above by approx. 50 CFM.

## Electric Heater Kits

NO.	Kit	Description	Breaker	Ref.Air Handler Use
1	CHE7W-05B	5 kW heater	Max.240 V,30 A,2 P	18, 24, 30, 36
2	CHE7W-08B	7.5 kW heater	Max.240 V,50 A,2 P	18, 24, 30, 36
3	CHE7W-10B	10 kW heater	Max.240 V,60 A,2 P	18, 24, 30, 36

## Electric Heater Kit Electrical Data (PCS)

Heater Kit Model Used	Air Handler Model	Electric Heat (kW)	Min. Circuit Ampacity		Max. Fuse or Breaker (HACR) Ampacity		Fan Speed (AC/HP)		
			240 V	208 V	240 V	208 V	Low	Medium	High
CHE7W-05B	18	5	28.5	25.0	30	30	●	●	●
CHE7W-08B		7.5	41.5	36.3	50	50	●	●	●
CHE7W-10B		10	54.5	47.6	60	60	●	●	●
CHE7W-05B	24	5	28.5	25.0	30	30	●	●	●
CHE7W-08B		7.5	41.5	36.3	50	50	●	●	●
CHE7W-10B		10	54.5	47.6	60	60	●	●	●
CHE7W-05B	30	5	28.5	25.0	30	30	●	●	●
CHE7W-08B		7.5	41.5	36.3	50	50	●	●	●
CHE7W-10B		10	54.5	47.6	60	60	●	●	●
CHE7W-05B	36	5	28.5	25.0	30	30	●	●	●
CHE7W-08B		7.5	41.5	36.3	50	50	●	●	●
CHE7W-10B		10	54.5	47.6	60	60	●	●	●

## Features

- Direct-drive, multi-speed motors allow air volume variation for heating / cooling.
  - Multi-speed ECM motor: CWM7(E) series
  - Multi-speed PSC motor: CWM7(P) series
- Thermoplastic drain pan with bottom primary and secondary drain connections.
- Built-in filter rack.
- Wall-hanging bracket included.
- Front or bottom return available.
- Optional heating elements in 5kW, 7.5kW, and 10kW.
- All-aluminum coil.
- AHRI listed and ETL listed.
- R454B refrigerant sensor is configured to ensure safe operation.
- R454B refrigerant sensor is factory-installed, more rooms are available for installation.

**ComfortStar®**

---

Add.: 12201 N W 107th Avenue Miami, FL 33178

1.866.524.9898 Toll Free

305.500.9898 Office

305.500.9896 Fax document.

<http://www.comfortstarusa.com>