

ComfortStar®

Air Conditioning & Heating Products



EN

Installation Manual

CWM32-18-15 (339)
CWM32-24-15 (33A)
CWM32-30-15 (33B)
CWM32-36-15 (33C)



IMPORTANT NOTE:



Read this manual carefully before installing or operating your new air conditioning unit. Make sure to save this manual for future reference.

CONTENTS

| | |
|---|----|
| 1 SAFETY | |
| • 1.1 Safety Signs | 02 |
| • 1.2 Safety Precautions | 03 |
| 2 ABOUT THE PRODUCT | |
| • 2.1 Preparation and precautions for indoor unit installation | 07 |
| • 2.2 Indoor unit parts installation size | 10 |
| • 2.3 Recommended size of filter | 10 |
| • 2.4 Operating temperature | 10 |
| 3 INSTALLATION | |
| • 3.1 Installation position requirements | 11 |
| • 3.2 Selection of installation direction | 12 |
| • 3.3 Connecting the wire and pipes(pipes and drainage pipes) | 12 |
| • 3.4 Refrigerant charge and room area limitations | 13 |
| • 3.5 Airflow performance (ameristar air handlers are Suitable for mobile home applications) | 16 |
| 4 DUCTWORK | 18 |
| 5 INSTALLATION OF ELECTRIC AUXILIARY HEAT MODULE | 19 |
| (ONLY FOR HEAT FUNCTION MODELS) | |
| 6 CONFIRMATION OF INDOOR UNIT | 21 |
| 7 INDOOR UNIT WIRING | 24 |
| 8 SPECIFIC WIRING METHODS | |
| • 8.1 Connection method | 25 |
| • 8.2 Self diagnosis function Error code table (indoor unit display) | 30 |
| • 8.3 Wiring Diagrams-ECM fan | 31 |
| • 8.4 Wiring Diagrams--AC fan | 31 |
| 9 MAINTENANCE | 32 |

This document is customer property and is to remain with this unit.

These instructions do not cover all the different variations, nor do they provide nor does it provide for every possible contingency to be met in connection with installation.

All phases of this installation must comply with national state and local codes. If additional information is required, please contact your local distributor.

This appliance is not intended for use by people (including children) with reduced physical, sensory or mental capabilities or people who lack experience and knowledge, unless they are supervised or have been given instructions concerning the use of the appliance by a person responsible for their safety. Children should be supervised to ensure that they do not play with the appliance.

1 SAFETY

1.1 Safety Signs



This is the general warning sign. It is used to alert the user to potential hazards. All safety messages that follow this sign shall be obeyed to avoid possible harm

DANGER

indicates a hazardous situation which, if not avoided, will result in death or serious injury

WARNING

indicates a hazardous situation which, if not avoided, could result in death or serious injury

CAUTION

indicates a hazardous situation which, if not avoided, could result in minor or moderate injury





NOTICE

is used to address practices not related to physical injury

For appliances using FLAMMABLE REFRIGERANTS with safety features that depend upon the proper function of a leak detection system used for leak mitigation, the instructions and unit markings shall contain the substance of the following:

"LEAK DETECTION SYSTEM installed. Unit must be powered except for service." If any remote located REFRIGERANT SENSOR is employed to detect leaked refrigerant, such a remote located REFRIGERANT SENSOR shall also apply to this marking or be accompanied by such instructions.

Explanation of symbols displayed on the unit

| | | |
|---|----------------|--|
|  | DANGER | This symbol shows that this appliance uses a mildly flammable refrigerant. If the refrigerant gets leaked and exposed to an external ignition source, there is a risk of fire. |
|  | WARNING | This symbol shows that appliance shall be installed, operated and stored in a room with a floor area not less than the minimum room area. |
|  | CAUTION | This symbol shows that the operation manual should be read carefully. |
|  | CAUTION | This symbol shows that a service personnel should be handling this equipment with reference to the installation manual. |
|  | CAUTION | This symbol shows that information is available such as in the operating manual or installation manual. |

1.2 Safety Precautions

⚠ DANGER

Disconnect **all** power to unit before installing or servicing. More than one disconnect switch may be required to de-energize the equipment. Hazardous voltage can cause severe personal injury or death.

⚠ WARNING

If removal of the blower assembly is required, **all** disconnect switches supplying power to the equipment must be de-energized and locked (if not in sight of unit), so the field power wires can be safely removed from the blower assembly. Failure to do so may cause electrical shock, resulting in personal injury or death.

⚠ WARNING

The unit must be permanently grounded. Failure to do so may result in electrical shock, causing personal injury or death.

⚠ WARNING

Because of possible damage to equipment or personal injury, installation, service, and maintenance should be performed by a trained, qualified service personnel. Consumer service is recommended only for filter cleaning / replacement. Never operate the unit with the access panels removed.

⚠ WARNING

These instructions are intended as an aid to qualified, licensed service personnel for proper installation, adjustment and operation of this unit. Read these instructions thoroughly before attempting installation or operation. Failure to follow these instructions may result in improper installation, adjustment, service or maintenance, possibly resulting in fire, electrical shock, property damage, personal injury or death.

⚠ CAUTION

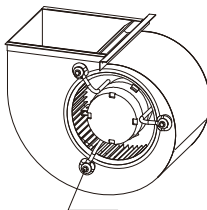

BLOWER MOTOR SHIPPING BOLT

Make sure the blower motor support is tight (3-motor mount bolts), then check if wheel is secured to the motor shaft before operating the unit.

Fig.1-1 Checking Motor Fix Status

⚠ WARNING

The first 6 inches of supply air plenum and ductwork must be constructed of sheet metal as required by NFPA 90B. The supply air plenum or duct must have a solid sheet metal bottom directly under the unit with no openings, registers or flexible air ducts located in it. If flexible supply air ducts are used, they may be located only in the vertical walls of rectangular plenum, a minimum of 6 inches from the solid bottom. Metal plenum or duct may be connected to the combustible floor base, if not, it must be connected to the unit supply duct exposed to the supply air opening from the downflow unit. Exposing combustible (non-metal) material to the supply opening of a downflow unit can cause a fire resulting in property damage, personal injury or death.

⚠ WARNING

PROPOSITION 65: This appliance contains fiberglass insulation. Respirable particles of fiberglass are known to the State of California to cause cancer.

All manufacturer products meet current federal OSHA Guidelines for safety. California Proposition 65 warnings are required for certain products, which are not covered by the OSHA standards.

California's Proposition 65 requires warnings for products sold in California that contain or produce any of over 600 listed chemicals known to the State of California to cause cancer or birth defects such as fiberglass insulation, lead in brass, and combustion products from natural vapor.

All "new equipment" shipped for sale in California will have labels stating that the product contains and/or produces Proposition 65 chemicals. Although we have not changed our processes, having the same label on all our products facilitates manufacturing and shipping. We cannot always know "when, or if" products will be sold in the California market.

You may receive inquiries from customers about chemicals found in, or produced by, some of our heating and air-conditioning equipment, or found in natural vapor used with some of our products. Listed below are those chemicals and substances commonly associated with similar equipment in our industry and other manufacturers.

- Glass Wool (Fiberglass) Insulation
- Carbon Monoxide (CO)
- Formaldehyde
- Benzene

More details are available on the following websites: OSHA (Occupational Safety and Health Administration), at www.osha.gov and the State of California's OEHHA (Office of Environmental Health Hazard Assessment), at www.oehha.org. Consumer education is important since the chemicals and substances on the list are found in our daily lives. Most consumers are aware that products present safety and health risks, when improperly used, handled and maintained.

⚠ WARNING

Only use this unit in a well-ventilated area and ensure unit's airflow inlet and outlet would not be impeded by obstructions. Do not use this unit in the following locations:

Locations with mineral oil.

Locations with saline atmospheres, such as seaside locations.

Locations with sulphurous atmospheres, such as near natural hot springs.

Where high voltage electricity is present, such as in certain industrial locations.

On vehicles or vessels, such as trucks or ferry boats.

Where exposure to oily or very humid air may occur, such as kitchens.

In proximity to sources of electromagnetic radiation, such as high-frequency transmitters or other high strength radiation devices.

⚠ WARNING

Do not use means to accelerate the defrosting process or to clean, other than those recommended by the manufacturer.

The appliance shall be stored in a room that does not have continuously operating ignition sources (for example: open flames, an operating gas appliance or an operating electric heater).

Do not pierce or burn the unit.

Be aware that refrigerants may not contain an odour.

If refrigerant gas leaks during installation, ventilate the area immediately.

Comply with national gas regulations.

⚠ WARNING

This appliance is not intended for use by people (including children) with reduced physical, sensory or mental capabilities, or people who lack experience and knowledge, unless they are supervised or have been given instructions concerning the use of the appliance by a person responsible for their safety.

Children should be supervised to ensure that they do not play with the appliance.

Any person who is involved with working on or opening a refrigerant circuit should hold a current valid certificate from an industry-accredited assessment authority, which authorizes their competence to handle refrigerants safely in accordance with an industry recognized assessment credential.

Servicing shall only be performed as recommended by the equipment manufacturer.

Maintenance and repair requiring the assistance of other skilled personnel shall be carried out under the supervision of a person competent in the use of flammable refrigerants.

Prior to beginning work on systems containing flammable refrigerants, safety checks are necessary to minimize the risk of ignition.

⚠ WARNING

When repairing the refrigerating system, comply with the following precautions prior to conducting work on the system:

- shall be undertaken according to controlled procedures so as to minimize the risk of the presence of flammable gases or vapors while the work is being performed.

- All maintenance staff and others working in the local area shall be instructed on the nature of the work being carried out. Work in confined spaces shall be avoided.

- The area shall be checked with an appropriate refrigerant detector prior to and during work, to ensure the technician is aware of potentially toxic or flammable environment. Ensure that the leak detection equipment being used is suitable for use with all applicable refrigerants, i.e. non-sparking, adequately sealed or intrinsically safe.

- If any hot work is to be conducted on the refrigerating equipment or any associated parts, appropriate fire extinguishing equipment shall be available and easily accessible. Have a dry powder or CO2 fire extinguisher adjacent to the charging area.

- When carrying out work in relation to a refrigerating system that involves exposing any pipe work, no sources of ignition shall be used in such a manner that it may lead to the risk of fire or explosion. All possible ignition sources, including cigarette smoking, should be kept sufficiently far away from the site of installation, repair, or removal and disposal of the unit, during which refrigerant can possibly be released into the surrounding space. Prior to beginning work, the area around the equipment is to be surveyed to make sure that there are no flammable hazards or ignition risks. "No Smoking" signs shall be clearly displayed.

Ensure that the area is in the open or that it is adequately ventilated before opening the system or conducting any hot work. A degree of ventilation shall continue during the period that the work is carried out. The ventilation should safely disperse any released refrigerant and preferably expel it externally into the surroundings.

Where electrical components are being changed, they shall be fit according to their purpose and to the correct specification. At all times the manufacturer's maintenance and service guidelines shall be followed. If in doubt, consult the manufacturer's technical department for assistance. The following checks shall be applied to installations using flammable refrigerants:

- The actual refrigerant charge is in accordance with the room size within which the refrigerant containing parts are installed;

- The ventilation machinery and outlets are operating adequately and are not obstructed.

- If an indirect refrigerating circuit is being used, the secondary circuit shall be checked for the presence of refrigerant.

- Equipment marking must remain visible and legible. Markings and signs that are illegible shall be corrected.

Refrigerating pipe or components are installed in a position where they are unlikely to be exposed to any substances which may corrode refrigerant containing components, unless the components are constructed of materials that are inherently resistant to corrosion or are suitably protected against corrosion.

Repair and maintenance of electrical components shall include initial safety checks and component inspection procedures. If a fault exists that could compromise safety, then no electrical supply shall be connected to the circuit until the fault has been dealt with satisfactorily.

If the fault cannot be corrected immediately but it is necessary to continue operation, an adequate temporary solution shall be used. This shall be reported to the owner of the equipment so that all parties are advised. Initial safety checks shall include:

- That capacitors are discharged: this shall be done in a safe manner to avoid the possibility of sparking;

- That no live electrical components and wiring are exposed while charging, recovering or purging the system;

- That there is continuity of earthing.

⚠ WARNING

Sealed electrical components shall be replaced.

Intrinsically safe components must be replaced.

Check that cabling will not be subject to wear, corrosion, excessive pressure, vibration, sharp edges or any other adverse environmental effects. The check shall also take into account the effects of aging or continual vibration from sources such as compressors or fans.

Under no circumstances shall potential sources of ignition be used while searching for or detecting refrigerant leaks. A halide torch (or any other detector using a naked flame) shall not be used.

Electronic leak detectors may be used to detect refrigerant leaks but, in the case of flammable refrigerants, the sensitivity may not be adequate, or may need re-calibration. (Detection equipment shall be calibrated in a refrigerant-free area.) Ensure that the detector is not a potential source of ignition and is suitable for the refrigerant used. Leak detection equipment shall be set at a percentage of the LFL of the refrigerant and shall be calibrated for the refrigerant employed, and the appropriate percentage of gas (25 % maximum) is confirmed.

If a leak is suspected, all naked flames shall be removed/extinguished.

If a leakage of refrigerant which requires brazing is found, all of the refrigerant shall be recovered from the system, or isolated (by means of shut off valves) in a part of the system remote from the leak.

Leak detection fluids are also suitable for use with most refrigerants but the use of detergents containing chlorine shall be avoided as the chlorine may react with the refrigerant and corrode the copper pipe-work.

NOTICE: Examples of leak detection fluids are

- bubble method,

- fluorescent method agents.

When breaking into the refrigerant circuit to make repairs - or for any other purpose -conventional procedures shall be used. However, for flammable refrigerants it is important that best practice be followed, since flammability is a consideration. The following procedure shall be adhered to:

- safely remove refrigerant following local and national regulations.

- evacuate.

- purge the circuit with inert gas .
- evacuate.
- continuously flush or purge with inert gas when using flame to open circuit, and,
- open the circuit.

The refrigerant charge shall be recovered into the correct recovery cylinders if venting is not allowed by local and national codes. For appliances containing flammable refrigerants, the system shall be purged with oxygen-free nitrogen to render the appliance safe for flammable refrigerants. This process might need to be repeated several times. Compressed air or oxygen shall not be used for purging refrigerant systems.

For appliances containing flammable refrigerants, refrigerants purging shall be achieved by breaking the vacuum in the system with oxygen-free nitrogen and continuing to fill until the working pressure is achieved, then venting to atmosphere, and finally pulling down to a vacuum. This process shall be repeated until no refrigerant is within the system. When the final oxygen-free nitrogen charge is used, the system shall be vented down to atmospheric pressure to enable work to take place.

The outlet for the vacuum pump shall not be close to any potential ignition sources, and ventilation shall be available.

Ensure that contamination of different refrigerants does not occur when using charging equipment. Hoses or lines shall be as short as possible to minimize the amount of refrigerant they contain.

Cylinders shall be kept upright. Ensure that the refrigeration system is grounded prior to charging the system with refrigerant.

Label the system when charging is complete (if it is not already labeled).

Take extreme care not to overfill the refrigeration system.

Prior to recharging the system, it shall be pressure-tested with the appropriate purging gas. The system shall be leak-tested on completion of charging but prior to commissioning. A follow up leak test shall be carried out prior to leaving the site.

Before carrying out this procedure, it is essential that the technician is completely familiar with the equipment and all its detail. It is recommended that all refrigerants are recovered safely. Prior to the task being carried out, an oil and refrigerant sample shall be taken in case analysis is required prior to re-use of reclaimed refrigerant. It is essential that electrical power is available before the task is commenced.

- a) Become familiar with the equipment and its operation.
- b) Isolate system electrically.
- c) Before attempting the procedure ensure that:
 - mechanical handling equipment is available, if required, for handling refrigerant cylinders;
 - all personal protective equipment is available and used correctly;
 - the recovery process is supervised at all times by a competent person;
 - recovery equipment and cylinders conform to the appropriate standards.
- d) Pump down refrigerant system, if possible.
- e) If a vacuum is not possible, make a manifold so that refrigerant can be removed from various parts of the system.
- f) Make sure that the cylinder is situated on the scales before recovery takes place.
- g) Start the recovery machine and operate it in accordance with the manufacturer's instructions.
- h) Do not overfill cylinders. (No more than 80 % volume liquid charge).
- i) Do not exceed the maximum working pressure of the cylinder, even temporarily.

j) When the cylinders have been filled correctly and the process has been completed, make sure that the cylinders and the equipment are removed from site promptly and all isolation valves on the equipment are closed off.

k) Recovered refrigerant shall not be charged into another refrigeration system unless it has been cleaned and checked.

Equipment shall be labeled stating that it has been de-commissioned and emptied of refrigerant. The label shall be dated and signed. Ensure that there are labels on the equipment stating that the equipment contains flammable refrigerant.

When removing refrigerant from a system, either for servicing or decommissioning, it is recommended that all refrigerants are removed safely.

When transferring refrigerant into cylinders, ensure that only appropriate refrigerant recovery cylinders are employed. Ensure that the correct number of cylinders for holding the total system charge is available. All cylinders to be used are designated for the recovered refrigerant and labelled for that refrigerant (i.e. special cylinders for the recovery of refrigerant). Cylinders shall be complete with pressure-relief valve and associated shut-off valves in good working order. Empty recovery cylinders are evacuated and, if possible, cooled before recovery occurs.

The recovery equipment must be in good working order and come with a set of instructions for proper usage. Furthermore, the equipment should be suitable for safely recovering flammable refrigerants. If in doubt, the manufacturer should be consulted. In addition, a set of calibrated weighing scales shall be available and in good working order. Hoses shall be complete with leak-free disconnect couplings and in good condition.

The recovered refrigerant shall be processed according to local legislation in the correct recovery cylinder, and the relevant waste transfer note arranged. Do not mix refrigerants in recovery units and especially not in cylinders.

If compressors or compressor oils are to be removed, ensure that they have been evacuated to an acceptable level to be certain that flammable refrigerant does not remain within the lubricant. The compressor body shall not be heated by an open flame or other ignition sources to accelerate this process. When oil is drained from a system, it shall be carried out safely.

Do not use the air conditioner for other purposes. In order to avoid any quality deterioration, do not use the unit for the cooling of precision instruments, food, plants, animals or works of art. Before cleaning, be sure to stop the operation, turn the breaker off or unplug the supply cord. Otherwise, electric shock and injury may occur.

In order to avoid electric shock or fire, make sure that a ground leak detector is installed.

Never touch the air outlet or the horizontal blades while the swing flap is in operation. Your fingers may be caught or the unit may break down.

Never put any objects into the air inlet or outlet.

Objects touching the fan at high speed can be dangerous.

Never inspect or service the unit by yourself.

Ask a qualified service person to perform this task.

Do not dispose of this product as unsorted municipal waste. This waste should be collected separately for special treatment. Do not dispose of electrical appliances as unsorted municipal waste. Use separate collection facilities. Contact your local government for information regarding the connection systems available.

If electrical appliances are disposed of in landfills or dumps, hazardous substances can leak into the groundwater and get into the food chain, harming your health and well-being.

To prevent refrigerant leak, contact your dealer.

When the system is installed and operated in a small room, it is required to maintain the concentration of the refrigerant below the limit, in case a leak occurs. Otherwise, oxygen in the room may be affected, resulting in a serious accident.

The refrigerant in the air conditioner is safe and normally does not leak.

If the refrigerant leaks into the room and comes into contact with the fire of a burner, a heater or a cooker, a harmful gas could be released.

Turn off any combustible heating devices, ventilate the room, and contact the dealer from whom you purchased the unit.

Do not use the air conditioner until a service person confirms that the refrigerant leak is repaired.

Keep ventilation openings clear of obstruction.

⚠ CAUTION

Be sure the air conditioner is grounded.

In order to avoid electric shock, make sure that the unit is grounded and that the ground wire is not connected to a gas or water pipe, lightning conductor or telephone ground wire.

Do not operate the air conditioner with wet hands. An electric shock may happen.

Do not touch the heat exchanger fins. These fins are sharp and could cut you.

To avoid oxygen deficiency, ventilate the room sufficiently if equipment with a burner is used together with the air conditioner.

Arrange the drain hose to ensure smooth drainage. Incomplete drainage may cause wetting of the building, furniture, etc.

Never touch the internal parts of the controller.

Do not remove the blower access panel. Some parts inside are dangerous to touch, and machine issues may occur.

Attention is drawn to the fact that additional transportation regulations may exist with respect to the equipment containing a flammable gas. The maximum number of pieces of equipment or the configuration of the equipment permitted to be transported together will be determined by the applicable transport regulations.

Signs for similar appliances used in a work area are generally addressed by local regulations and give the minimum requirements for the provision of safety and/or health signs for a work location.

All required signs are to be maintained and employers should ensure that employees receive suitable and sufficient instruction and training on the meaning of appropriate safety signs and the actions that need to be taken in connection with these signs.

The effectiveness of signs should not be diminished by too many signs being placed together.

Any pictograms used should be as simple as possible and contain only essential details.

The storage of the appliance should be in accordance with the applicable regulations or instructions, whichever is more stringent.

Storage package protection should be constructed such a way that mechanical damage to the equipment inside the package will not cause a leak of the refrigerant charge.

The maximum number of pieces of equipment permitted to be stored together will be determined by local regulations.

Do not operate the air conditioner when using a room fumigation - type insecticide. Failure to observe this precaution could cause the chemicals to become deposited in the unit, which could endanger the health of those who are hypersensitive to chemicals. It may also cause the refrigerant sensor to alarm.

Do not place appliances which produce open flames in places exposed to the air flow from the unit or under the indoor unit. It may cause incomplete combustion or deformation of the unit due to the heat.

Do not install the air conditioner in a location where flammable gas may leak out. If the gas leaks out and stays around the air conditioner, a fire may break out.

Any additional equipment installed in our unit may not cause negative influence on normal operation, such as UV lights, humidifier and etc.

The appliance uses R32 refrigerant.

⚠ CAUTION

CC.1 General

The following information is provided for units that employ FLAMMABLE REFRIGERANTS.

CC.2 Transport of equipment containing flammable refrigerants

Attention is drawn to the fact that additional transportation regulations may exist with respect to equipment containing flammable gas. The maximum number of pieces of equipment or the configuration of the equipment transported together will be determined by the applicable transport regulations.

CC.3 Marking of equipment using signs

Signs for similar appliances used in a work area are generally addressed by local regulations and give the minimum requirements for the provision of safety and/or health signs for a work location. All required signs are to be maintained and employers should ensure that employees receive suitable and sufficient instruction and training on the meaning of appropriate safety signs and the actions that need to be taken in connection with these signs.

The effectiveness of signs should not be diminished by too many signs being placed together. Any pictograms used should be as simple as possible and contain only essential details.

CC.4 Disposal of equipment using flammable refrigerants

See national regulations

CC.5 Storage of equipment/appliances

The storage of the appliance should be in accordance with the applicable regulations or instructions, whichever is more stringent.

CC.6 Storage of packed (unsold) equipment

Storage package protection should be constructed in such a way that mechanical damage to the equipment inside the package will not cause a leak of the REFRIGERANT CHARGE.

The maximum number of pieces of equipment permitted to be stored together will be determined by local regulations.

2 ABOUT THE PRODUCT

⚠ WARNING

There must be an airtight seal between the bottom of the air handler and the return air plenum. Use fiberglass sealing strips, foil duct tape, caulking, or equivalent sealing method between the plenum and the air handler cabinet to ensure a tight seal. Return air must not be drawn from a room where this air handler or any gas-fueled appliance (i.e., water heater), or carbon monoxide-producing device (i.e., wood fireplace) is installed.

2.1 Preparation and precautions for indoor unit installation

Coil compartment
(Access panel Removed)

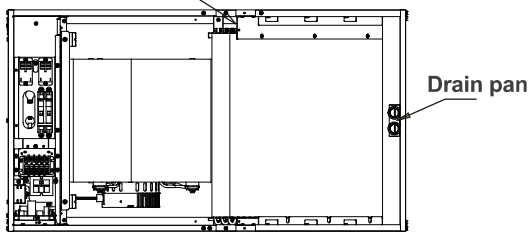

⚠ WARNING

- Please apply sealant around the places where the wires, refrigerant pipes and condensate pipes enter the cabinet.
- Use duct tape or flexible sealant to seal closed anyspace around the holes where the drain lines exit the cabinet. Warm air must not be allowed to enter through any gaps or holes in the cabinet.



● NOTICE

- Remove all accessories and packing in the air outlet before installation.

Check Equipment

Unpack unit and move to final location. Remove carton, taking care no to damage unit. Remove protective sheet metal from the base of the unit, if equipped. Inspect equipment for damage prior to installation. File claim with shipping company if shipment is damaged or incomplete. Locate rating plate on unit. It contains information needed to properly install unit. Check rating plate to be sure unit matches job specifications. A front access panel is provided, which permits access to blower assembly and electrical controls for removal and servicing.

NOTE: Minimum clearance of 21" (533 mm) is required in front of access panel for servicing only. Installation clearance from combustible materials is 0" (0 mm) from cabinet and supply-air duct (plenum included). Make sure there is adequate space on top of unit for refrigerant line connections and on bottom of unit for condensate trap (Fig. 1).

Mount Fan Coil

Fan Coil Mounting Options

The fan coil comes standard with two different options for mounting: wall mount or frame plate mount. Both mounting options require the unit to be level from side to side and from front to back in order to allow condensate to properly drain from the unit. Failure to do this will result in condensate leaking out from the unit, potentially causing structural damage to the surrounding support structures, drywall, carpet, etc. around the unit. Also, both mounting structures require the ability to accommodate a minimum of load of 150 pounds. Failure to do this will cause damage to the support structure and potentially damage the unit.

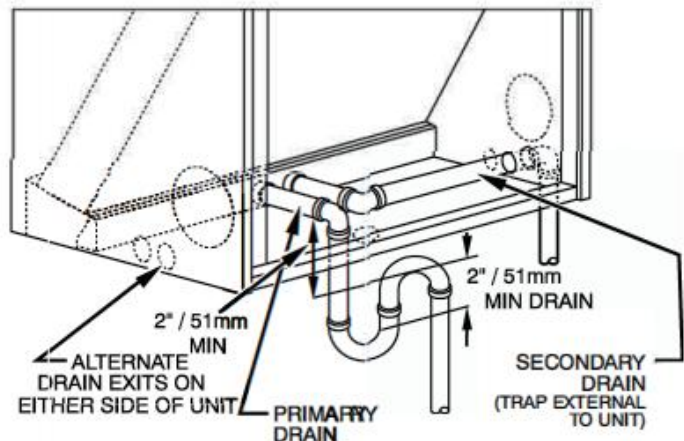

NOTE: Use plastic pipe from condensate pan to exterior of fan coil

Fig. 2 - Condensate Drain

WallMount

The fan coil comes standard with a wall mounting bracket and fan coil mounting bracket. Refer to Fig. 3 for more detail.

1. Remove the wall mounting bracket from the back of the unit by removing one screw which attaches the bracket to the fan coil. NOTE: Discard the screw after you have removed the wall mounting bracket.

2. Install bracket on the wall by using three wood screws (not provided) per wall-mount bracket. Make sure the bracket is level in order to provide proper drainage from the unit.

NOTE: Do not attach the wall mounting bracket into unsupported drywall. Make sure that the wood screws are going into a structure that can support a minimum load of 150 pounds.

3. Lift the fan coil above the wall mounting bracket and attach the unit to the installed bracket. Refer to Fig. 3.

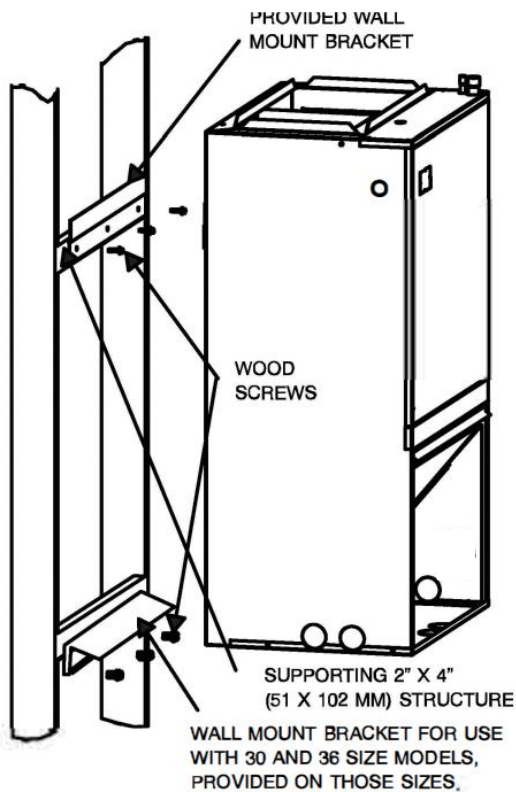
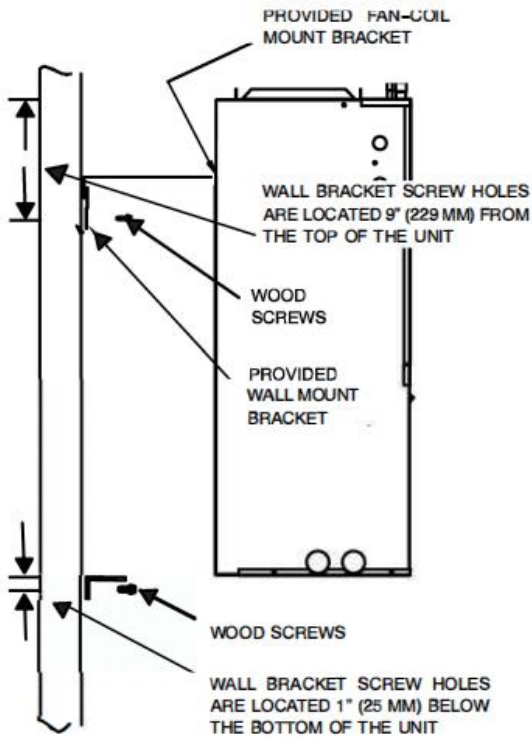

Fig. 3 - Wall Mount Installation

Frame Mount

The fan coil comes with eight clearance holes, four on each side. These holes are used to mount the fan coil inside a frame structure (Fig. 4).

When mounting in this fashion, make sure that the wood screws are mounted from within the fan coil and not outside of the unit. Installing the screws from outside of the unit may damage the coil.

After moving unit into place, install refrigerant tubing as follows:

1. Route tubing to connection points, taking care not to block service access.
2. Remove plugs from liquid and vapor lines.
3. Braze connections using either silver bearing or non-silver bearing brazing material. Do not use soft solder (materials which melt below 800°F / 427°C). Consult local code requirements. Always flow nitrogen through the system refrigerant lines while brazing.
4. Pressurize system and leak-test. Repeat procedure until leak-free.

Ductwork Specifications

Connect supply-air duct over 3/4" (19 mm) flange provided on supply-air opening. Secure duct to flange using applicable fasteners for type of duct used, and seal duct-to-unit joint.

NOTE: Short duct runs tend to increase noise level.

When fan coil is equipped with an electric heater, install air ducts in accordance with standards 90A and 90B of National Fire Protection Association(NFPA). Use of flexible connectors between ductwork and unit will prevent transmission of vibration. When electric heater is installed, use heat-resistant material for a flexible connector between ductwork and unit air discharge connection. Ductwork passing through unconditioned space must be insulated and covered with a vapor barrier.

NOTE: Unit is intended for non-ducted return-air applications. Product Data sheet includes a list of accessories, including louvered wall panels and return air opening grills. If ducted return is used, airflow must meet criteria established in the Product Data. Local codes may limit this unit to single-level applications. Design the duct system in accordance with "ACCA" Manual "D" Design for Residential Winter and Summer Conditioning and Equipment Selection. Latest editions are available from : "ACCA" Air Conditioning Contractors of America. If duct system incorporates flexible air duct, be sure pressure drop information (straight length plus all turns) shown in "ACCA" Manual "D" is accounted for in system.

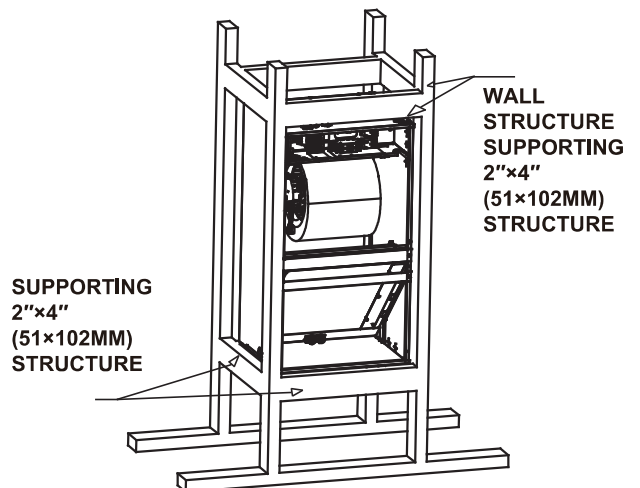

Fig. 4 - Frame Mount Installation

⚠ WARNING

Injury Hazard

Failure to follow this warning could result in personal injury or death. Do not, under any circumstances, connect return ductwork to any other heat-producing device such as fireplace inserts, stoves, etc. Unauthorized use of such devices may result in fire, carbon monoxide poisoning, explosion, personal injury or property damage.

⚠ CAUTION

Environmental Hazard

Failure to follow this caution may result in environmental damage. Do not vent refrigerant to atmosphere. Recover during system repair or final unit disposal.

Conversion to Bottom Return

This product is shipped configured for front return and can be converted for bottom return. To convert the unit to bottom return, remove the bottom panel and lower front panel (short panel above front opening and below the filter slot). Attach the panel removed from the bottom of the unit to the front return opening.

Condensate Drain

Condensate pan has primary and secondary drain connections to meet FHA requirements (Fig. 2). These connections have 3/4" (19 mm) female pipe threads. Tubing for all condensate drains should be a minimum of 7/8" (22 mm) OD. Drain lines from condensate pan to exterior of unit must be plastic pipe. Drain should be pitched downward at a slope of 1" per 10 feet (25 mm per 3 m). If coil is located in or above a living space where damage may result from condensate overflow, a separate 3/4" (19 mm) drain must be provided from secondary drain connection. Run this drain to a place in compliance with local installation codes where it will be noticed when unit is operational.

Condensate flow from secondary drain indicates a plugged primary drain. Install a 2" (51 mm) trap in condensate drain line as close to coil as possible. A factory approved drain trap kit is available. Make sure that the top of trap is below connection to drain pan to prevent condensate from overflowing drain pan. Prime all traps, test for leaks, and insulate in areas where sweating of the traps and drain lines could potentially cause water damage. Consult local codes for additional restrictions or precautions.

Optional extrusions are provided on the bottom panel if the installer wishes to secure the drain lines.

2.2 Indoor unit parts installation size

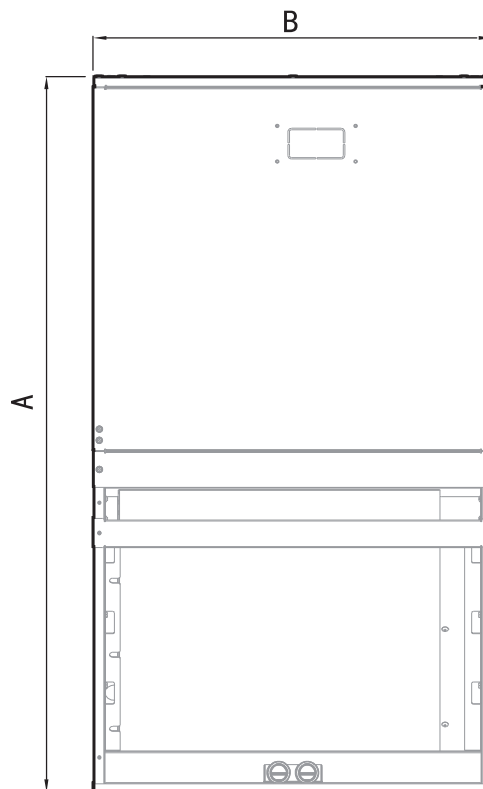
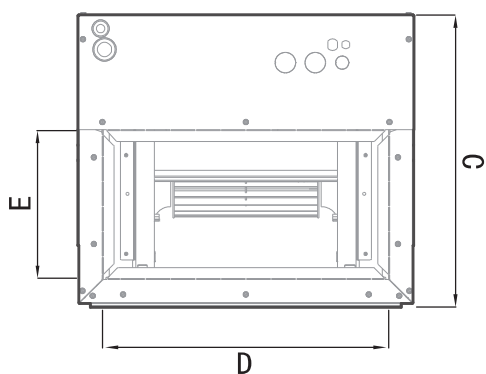

Model

| Model(Btu/h) | | 18K/24K | 30K/36K |
|--------------|------|----------|----------|
| Length of A | mm | 1004 | 1004 |
| | inch | 45 | 39-17/32 |
| Length of B | mm | 445 | 562 |
| | inch | 17-33/64 | 22-1/8 |
| Length of C | mm | 534 | 483 |
| | inch | 21-1/32 | 19-1/64 |
| Length of D | mm | 400 | 478 |
| | inch | 15-3/4 | 18-13/64 |
| Length of E | mm | 260 | 248 |
| | inch | 10-15/64 | 9-49/64 |

2.3 Recommended size of filter

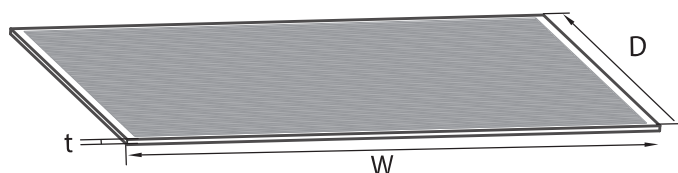

NOTE:

The user needs to use a standard filter that meets the requirements of UL900 or CAN/ULC-S111; (Not Factory installed)

(unit: mm/inch)

| Model(Btu/h) | | 18K/24K | 30K/36K |
|--------------|------|----------|----------|
| Length of W | mm | 310 | 440 |
| | inch | 12-13/64 | 17-21/64 |
| Length of D | mm | 483 | 508 |
| | inch | 19 | 20 |
| Length of t | mm | 25.4 | 25.4 |
| | inch | 1 | 1 |

2.4 Operating temperature

| Mode | Operational temperature | |
|----------------------------|-------------------------|----------|
| | Indoor | Outdoor |
| Cooling | 17~32°C | -5~52°C |
| Heating | 17~32°C | -20~30°C |
| Electric auxiliary heating | 31°C or less | |

CAUTION:

1. If air conditioner is used outside of the above conditions, Certain safety protection features may come into operation and cause the unit to function abnormally.
2. Room relative humidity less than 80%. If the air conditioner operates in excess of this figure, the surface of the air conditioner may attract condensation. Please set the vertical air flow to its maximum angle (vertically to the floor), and set HIGH fan mode.
3. Optimum performance will be achieved within these operating temperature.

3.INSTALLATION

3.1 Installation Position Requirements

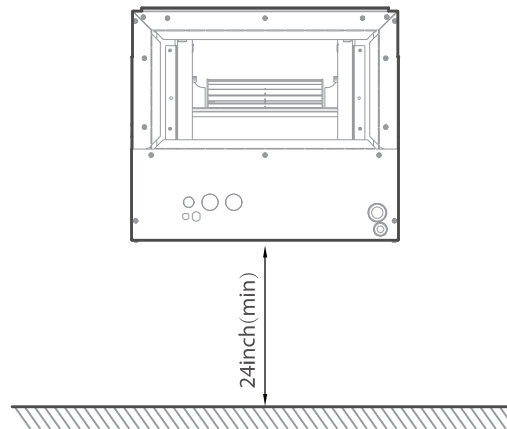

● NOTICE FOR DUCT CONNECTIONS :



It should be assembled accordance to the instructions.



It should be insulated and use a Vapor Barrier.

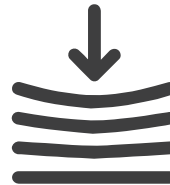

It should be Flexible suspension mounted and not fastened



It should be fabricated and installed in accordance with local and/or national codes.

More Requirements

- Air supply and return may be handled in one of several ways best suited to the installation (See table for dimensions for duct inlet and outlet connections). The vast majority of problems encountered with combination cooling systems can be linked to improperly designed or installed duct systems. It is therefore highly important to the success of an installation that the duct system be properly designed and installed. Use flexible duct collars to minimize the transmission of vibration/noise into the conditioned space. Where return air duct is short, or where sound could potentially to be a problem, sound absorbing liner should be used inside the duct.
- Duct must be insulated where it runs through an unconditioned space during the cooling season. The use of a vapor barrier is recommended to prevent absorption of moisture from the surrounding air into the insulation.
- The supply air duct connection should be properly sized by use of a transition to match unit opening.
- All ducts should be suspended using flexible hangers and never fastened directly to the structure. This unit is not designed for nonducted (freeblow) applications.
- Duct work should be fabricated and installed in accordance with local and/or national codes.

CAUTION

A field-fabricated secondary drain pan, with a drain pipe to the outside of the building, is required in all installations over a finished living space or in any area that may be damaged by overflow from the main drain pan. In some localities, local codes may require a secondary drain pan for any horizontal installation.

3.2 Selection of installation direction

The fan coil comes standard with two different options for mounting: front return air type or bottom return air type. Both installation methods require the equipment to be placed vertically in order to allow condensate to properly drain from the unit. Failure to do this will result in condensate leaking out from the unit, potentially causing structural damage to the surrounding support structures, drywall, carpet, etc. around the unit. Also, both mounting structures require the ability to accommodate a minimum of load of 150 pounds. Failure to do this will cause damage to the support structure and potentially damage the unit.

Airflow direction of different installation directions

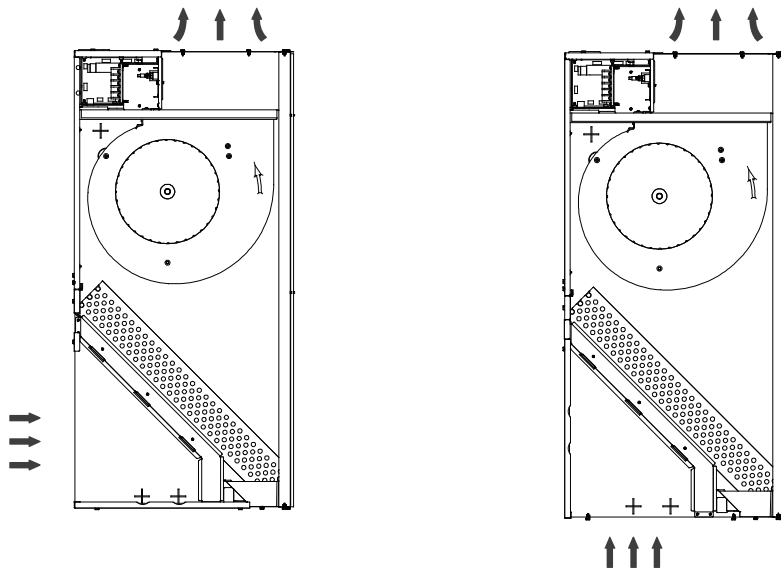

NOTICE

- The above two installation methods do not need to change the direction of evaporator.

3.3 Connecting the wire and pipes(pipes and drainage pipes)

Please follow these steps to perform front return air installation and bottom return air installation:

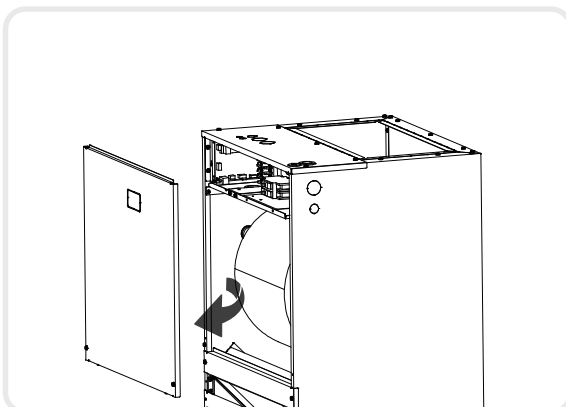

Step 1

Open the upper cover.

Step 2

Open the cover of the electronic control box.

Step 3

Connect the wire according to the wiring diagram.

Step 4

Connect the pipes and install the drainage pipes.

3.4 Refrigerant Charge and Room Area Limitations

In UL/CSA 60335-2-40, R32 refrigerant is classified as class A2L, which is mildly flammable. Therefore, R32 refrigerant would limit the area of the rooms being served.

Similarly, the total amount of refrigerant in the system shall be less than or equal to the allowable maximum refrigerant charge. The allowable maximum refrigerant charge depends on the area of the rooms being served by the system.

NOTICE

The nouns in this section are explained as follows:

m_c : The actual refrigerant charge in the system.
 A : the actual room area where the appliance is installed.

A_{min} : The required minimum room area.

m_{max} : The allowable maximum refrigerant charge in a room.

Q_{min} : The minimum circulation airflow.

Anv_{min} : The minimum opening area for connected rooms.

TA_{min} : The total area of the conditioned space (For appliances serving one or more rooms with an air duct system).

TA : The total area of the conditioned space connected by air ducts.

3.4.1 The room area calculation requirements

CAUTION

The space considered shall be any space which contains refrigerant-containing parts or into which refrigerant could be released.

The room area (A) of the smallest, enclosed, occupied space shall be used in the determination of the refrigerant quantity limits.

For determination of room area (A) when used to calculate the refrigerant charge limit, the following shall apply.

The room area (A) shall be defined as the room area enclosed by the projection to the base of the walls, partitions and doors of the space in which the appliance is installed.

Spaces connected by only drop ceilings, ductwork, or similar connections shall not be considered a single space.

Units mounted higher than 70-55/64 inches and spaces divided by partition walls that are no higher than 62-63/64 inches shall be considered a single space.

Rooms on the same floor and connected by an open passageway between the spaces can be considered a single room when determining compliance to A_{min} , if the passageway complies with all of the following.

- 1) It is a permanent opening.
- 2) It extends to the floor.
- 3) It is intended for people to walk through.

The area of the connected rooms, on the same floor, connected by permanent opening in the walls and/or doors between occupied spaces, including gaps between the wall and the floor, can be considered a single room when determining compliance to A_{min} , provided all of the following conditions are met as Fig. 5.

1) Low level opening

- ① The opening shall not be less than Anv_{min} in Table 5-1.
- ② The area of any openings above 11-13/16 inches from the floor shall not be considered in determining compliance with Anv_{min} .
- ③ At least 50 % of the opening area of Anv_{min} shall be below 7-7/8 inches from the floor.
- ④ The bottom of the opening is not more than 3-15/16 inches from the floor.

⑤ The opening is a permanent opening that cannot be closed.

⑥ For openings extending to the floor the height shall not be less than 25/32 inches above the surface of the floor covering.

2) High level opening

① The opening shall not be less than 50 % of Anv_{min} in Table 3-1.

② The opening is a permanent opening that cannot be closed.

③ The opening shall be at least 59 inches above the floor.

④ The height of the opening is not less than 25/32 inches.

3) Room size requirement

① The room into which refrigerant can leak, plus the connected adjacent room(s) shall have a total area not less than A_{min} . A_{min} is shown in Table 5-3.

② The room area in which the unit is installed shall be not less than 20 % A_{min} . A_{min} is shown in Table 5-3.

NOTICE

The requirement for the second opening can be met by drop ceilings, ventilation ducts, or similar arrangements that provide an airflow path between the connected rooms.

The minimum opening for natural ventilation (Anv_{min}) in connected rooms is related to the room area (A), the actual refrigerant charge of refrigerant in the system (m_c), and the allowable MAXIMUM REFRIGERANT CHARGE in the system (m_{max}), Anv_{min} can be determined according to Table 5-1.

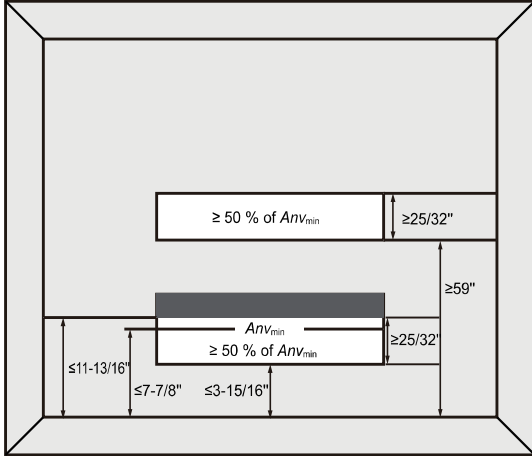

Fig.5 Opening Conditions for Connected Rooms

The minimum opening area for connected rooms

| A | | m_c | | m_{max} | | Anv_{min} | |
|-----------------|----------------|-------|-----|-----------|-----|-----------------|----------------|
| ft ² | m ² | lb-oz | kg | lb-oz | kg | ft ² | m ² |
| 100 | 10 | 17-3 | 7.8 | 6-10 | 3.0 | 1.3 | 0.13 |
| 110 | 11 | 17-3 | 7.8 | 7-5 | 3.3 | 1.2 | 0.12 |
| 120 | 12 | 17-3 | 7.8 | 8-0 | 3.6 | 1.1 | 0.11 |
| 130 | 13 | 17-3 | 7.8 | 8-10 | 3.9 | 1.0 | 0.10 |
| 140 | 14 | 17-3 | 7.8 | 9-5 | 4.2 | 1.0 | 0.10 |
| 150 | 14 | 17-3 | 7.8 | 10-0 | 4.5 | 0.9 | 0.09 |
| 160 | 15 | 17-3 | 7.8 | 10-10 | 4.8 | 0.8 | 0.08 |
| 170 | 16 | 17-3 | 7.8 | 11-5 | 5.1 | 0.7 | 0.07 |
| 180 | 17 | 17-3 | 7.8 | 12-0 | 5.4 | 0.6 | 0.06 |
| 190 | 18 | 17-3 | 7.8 | 12-10 | 5.7 | 0.5 | 0.05 |
| 200 | 19 | 17-3 | 7.8 | 13-5 | 6.0 | 0.5 | 0.05 |
| 210 | 20 | 17-3 | 7.8 | 14-0 | 6.3 | 0.4 | 0.04 |
| 220 | 21 | 17-3 | 7.8 | 14-10 | 6.6 | 0.3 | 0.03 |
| 230 | 22 | 17-3 | 7.8 | 15-5 | 6.9 | 0.2 | 0.02 |
| 240 | 23 | 17-3 | 7.8 | 16-0 | 7.2 | 0.1 | 0.01 |
| 250 | 24 | 17-3 | 7.8 | 16-10 | 7.5 | 0.1 | 0.01 |
| 260 | 25 | 17-3 | 7.8 | 17-5 | 7.8 | 0.0 | 0.00 |

Table 5-1

Note: Take the $m_c = 17$ lb 3 oz as an example.

For appliances serving two or more rooms with an air duct system, The room area calculation shall be determined based on the total area of the conditioned space (TA) connected by ducts taking into consideration that the circulating airflow distributed to all the rooms by the appliance integral indoor fan will mix and dilute the leaking refrigerant before entering any room.

3.4.2. The allowed maximum refrigerant charge and required minimum room area

If the fan incorporated in the appliance is continuously operated or operation is initiated by a REFRIGERANT DETECTION SYSTEM with a sufficient CIRCULATION AIRFLOW rate, the allowable maximum refrigerant charge (m_{max}) and the required minimum room area (A_{min}/TA_{min}) is shown in Table 5-2 and Table 5-3.

The allowable maximum refrigerant charge

| A/TA | | m_{max} | | A/TA | | m_{max} | |
|-----------------|----------------|-----------|-----|-----------------|----------------|-----------|-----|
| ft ² | m ² | lb-oz | kg | ft ² | m ² | lb-oz | kg |
| 30 | 3 | 2-0 | 0.9 | 150 | 14 | 10-0 | 4.5 |
| 40 | 4 | 2-10 | 1.2 | 160 | 15 | 10-10 | 4.8 |
| 50 | 5 | 3-5 | 1.5 | 170 | 16 | 11-5 | 5.1 |
| 60 | 6 | 4-0 | 1.8 | 180 | 17 | 12-0 | 5.4 |
| 70 | 7 | 4-10 | 2.1 | 190 | 18 | 12-10 | 5.7 |
| 80 | 8 | 5-5 | 2.4 | 200 | 19 | 13-5 | 6.0 |
| 90 | 9 | 6-0 | 2.7 | 210 | 20 | 14-0 | 6.3 |
| 100 | 10 | 6-10 | 3.0 | 220 | 21 | 14-10 | 6.6 |
| 110 | 11 | 7-5 | 3.3 | 230 | 22 | 15-5 | 6.9 |
| 120 | 12 | 8-0 | 3.6 | 240 | 23 | 16-0 | 7.2 |
| 130 | 13 | 8-10 | 3.9 | 250 | 24 | 16-10 | 7.5 |
| 140 | 14 | 9-5 | 4.2 | 260 | 25 | 17-5 | 7.8 |

Table 5-2

The required minimum room area

| m_c | | A_{min}/TA_{min} | | m_c | | A_{min}/TA_{min} | |
|-------|-----|--------------------|----------------|-------|-----|--------------------|----------------|
| lb-oz | kg | ft ² | m ² | lb-oz | kg | ft ² | m ² |
| 2-2 | 1.0 | 33.1 | 3.1 | 10-2 | 4.6 | 152.1 | 14.2 |
| 2-9 | 1.2 | 39.7 | 3.7 | 10-9 | 4.8 | 158.7 | 14.8 |
| 3-0 | 1.4 | 46.3 | 4.4 | 11-0 | 5.0 | 165.3 | 15.4 |
| 3-7 | 1.6 | 52.9 | 5.0 | 11-7 | 5.2 | 171.9 | 16.0 |
| 3-15 | 1.8 | 59.5 | 5.6 | 11-14 | 5.4 | 178.5 | 16.6 |
| 4-6 | 2.0 | 66.1 | 6.2 | 12-5 | 5.6 | 185.1 | 17.2 |
| 4-13 | 2.2 | 72.7 | 6.8 | 12-12 | 5.8 | 191.7 | 17.9 |
| 5-4 | 2.4 | 79.3 | 7.4 | 13-3 | 6.0 | 198.4 | 18.5 |
| 5-11 | 2.6 | 86.0 | 8.0 | 13-10 | 6.2 | 205.0 | 19.1 |
| 6-2 | 2.8 | 92.6 | 8.7 | 14-1 | 6.4 | 211.6 | 19.7 |
| 6-9 | 3.0 | 99.2 | 9.3 | 14-8 | 6.6 | 218.2 | 20.3 |
| 7-0 | 3.2 | 105.8 | 9.9 | 14-15 | 6.8 | 224.8 | 20.9 |
| 7-7 | 3.4 | 112.4 | 10.5 | 15-6 | 7.0 | 231.4 | 21.5 |
| 7-15 | 3.6 | 119.0 | 11.1 | 15-14 | 7.2 | 238.0 | 22.2 |
| 8-6 | 3.8 | 125.6 | 11.7 | 16-5 | 7.4 | 244.6 | 22.8 |
| 8-13 | 4.0 | 132.2 | 12.3 | 16-12 | 7.6 | 251.2 | 23.4 |
| 9-4 | 4.2 | 138.8 | 12.9 | 17-3 | 7.8 | 257.9 | 24.0 |
| 9-11 | 4.4 | 145.5 | 13.6 | | | | |

Table 5-3

The minimum circulation airflow

| m_c | | Q_{min} | | m_c | | Q_{min} | |
|-------|-----|-----------|-------------------|-------|-----|-----------|-------------------|
| lb-oz | kg | CFM | m ³ /h | lb-oz | kg | CFM | m ³ /h |
| 2-2 | 1.0 | 59 | 100 | 10-2 | 4.6 | 275 | 467 |
| 2-9 | 1.2 | 71 | 121 | 10-9 | 4.8 | 287 | 488 |
| 3-0 | 1.4 | 83 | 141 | 11-0 | 5.0 | 298 | 506 |
| 3-7 | 1.6 | 95 | 161 | 11-7 | 5.2 | 310 | 527 |
| 3-15 | 1.8 | 107 | 182 | 11-14 | 5.4 | 322 | 547 |
| 4-6 | 2.0 | 119 | 202 | 12-5 | 5.6 | 334 | 567 |
| 4-13 | 2.2 | 131 | 223 | 12-12 | 5.8 | 346 | 588 |
| 5-4 | 2.4 | 143 | 243 | 13-3 | 6.0 | 358 | 608 |
| 5-11 | 2.6 | 155 | 263 | 13-10 | 6.2 | 370 | 629 |
| 6-2 | 2.8 | 167 | 284 | 14-1 | 6.4 | 382 | 649 |
| 6-9 | 3.0 | 179 | 304 | 14-8 | 6.6 | 394 | 669 |
| 7-0 | 3.2 | 191 | 325 | 14-15 | 6.8 | 406 | 690 |
| 7-7 | 3.4 | 203 | 345 | 15-6 | 7.0 | 418 | 710 |
| 7-15 | 3.6 | 215 | 365 | 15-14 | 7.2 | 430 | 731 |
| 8-6 | 3.8 | 227 | 386 | 16-5 | 7.4 | 442 | 751 |
| 8-13 | 4.0 | 239 | 406 | 16-12 | 7.6 | 454 | 771 |
| 9-4 | 4.2 | 251 | 426 | 17-3 | 7.8 | 466 | 792 |
| 9-11 | 4.4 | 263 | 447 | | | | |

Table 5-4

● Installation scheme flow chart

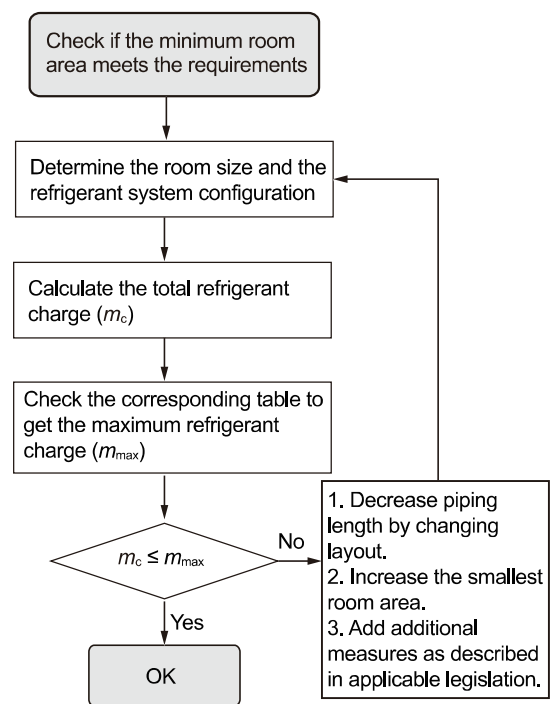

Fig.6

⚠ CAUTION

The allowable maximum refrigerant charge of the Table 5-2 or the required minimum room area of the Table 5-3 is available only if the following conditions are met:

Minimum velocity of 3.28 ft/s, which is calculated as the indoor unit airflow divided by the nominal face area of the outlet, the grill area shall not be deducted.

Minimum airflow rate must meet the corresponding values in Table 5-4, which is related to the actual refrigerant charge of the system (m_c).
R32 refrigerant leakage sensor is configured.

NOTICE

The maximum refrigerant limit described above applies to unventilated areas. If adding additional measures, such as areas with mechanical ventilation or natural ventilation, the maximum refrigerant charge can be increased or the minimum room area can be reduced.

The R32 refrigerant leakage sensor is configured for the indoor unit and meets the incorporated circulation airflow requirements. The maximum refrigerant charge or minimum room area can be determined according to Table 5-2 or Table 5-3.

⚠ CAUTION

If the actual room area, air outlet height, and refrigerant charge amount are not reflected in the above table, more severe cases need to be considered according to the data in the Table 5-1, 5-2, 5-3, 5-4.

3.5 AIRFLOW PERFORMANCE (COMFORTSTAR AIR HANDLERS ARE SUITABLE FOR MOBILE HOME APPLICATIONS)

Airflow performance data is based on cooling performance with a coil and no filter in place. Select performance table for appropriate unit size.
 External static applied to unit allows operation within the minimum and maximum limits shown in table below for both cooling and electric heat operation.

Airflow Performance Data

| Model | Motor Speed | | CFM Wet Coil without filter and Electric Heat | | | | | | | | | | |
|-------|-------------|-------------|---|------|------|------|------|------|------|------|------|------|------|
| | | | External Static Pressure (pa) | | | | | | | | | | |
| | | | 0 | 20 | 40 | 60 | 80 | 100 | 120 | 125 | 140 | 160 | 180 |
| 18 | Hi | CFM | 929 | 883 | 847 | 806 | 766 | 724 | 678 | 664 | 659 | 604 | 538 |
| | | Current / A | 1.9 | 1.79 | 1.75 | 1.71 | 1.67 | 1.64 | 1.6 | 1.58 | 1.56 | 1.50 | 1.45 |
| | | Power / W | 400 | 384 | 376 | 364 | 355 | 346 | 336 | 332 | 325 | 311 | 295 |
| | Mi | CFM | 749 | 714 | 681 | 648 | 611 | 572 | 559 | | 504 | 447 | |
| | | Current / A | 1.46 | 1.38 | 1.34 | 1.31 | 1.28 | 1.24 | 1.20 | | 1.16 | 1.10 | |
| | | Power / W | 307 | 297 | 289 | 281 | 273 | 264 | 256 | | 245 | 230 | |
| | Lo | CFM | 622 | 594 | 566 | 535 | 504 | 470 | 430 | | 368 | | |
| | | Current / A | 1.11 | 1.08 | 1.05 | 1.02 | 1.00 | 0.96 | 0.93 | | 0.86 | | |
| | | Power / W | 238 | 232 | 226 | 220 | 213 | 206 | 197 | | 180 | | |
| 24 | Hi | CFM | 929 | 883 | 847 | 806 | 766 | 724 | 678 | 664 | 659 | 604 | 538 |
| | | Current / A | 1.9 | 1.79 | 1.75 | 1.71 | 1.67 | 1.64 | 1.6 | 1.58 | 1.56 | 1.50 | 1.45 |
| | | Power / W | 400 | 384 | 376 | 364 | 355 | 346 | 336 | 332 | 325 | 311 | 295 |
| | Mi | CFM | 749 | 714 | 681 | 648 | 611 | 572 | 559 | | 504 | 447 | |
| | | Current / A | 1.46 | 1.38 | 1.34 | 1.31 | 1.28 | 1.24 | 1.20 | | 1.16 | 1.10 | |
| | | Power / W | 307 | 297 | 289 | 281 | 273 | 264 | 256 | | 245 | 230 | |
| | Lo | CFM | 622 | 594 | 566 | 535 | 504 | 470 | 430 | | 368 | | |
| | | Current / A | 1.11 | 1.08 | 1.05 | 1.02 | 1.00 | 0.96 | 0.93 | | 0.86 | | |
| | | Power / W | 238 | 232 | 226 | 220 | 213 | 206 | 197 | | 180 | | |
| 30 | Hi | CFM | 1356 | 1308 | 1256 | 1206 | 1152 | 1096 | 1036 | 1022 | 974 | 938 | 874 |
| | | Current / A | 2.32 | 2.30 | 2.29 | 2.28 | 2.27 | 2.25 | 2.24 | 2.23 | 2.22 | 2.20 | 2.19 |
| | | Power / W | 465 | 454 | 447 | 440 | 433 | 424 | 417 | 413 | 407 | 400 | 392 |
| | Mi | CFM | 1221 | 1165 | 1122 | 1078 | 1028 | 982 | 930 | 919 | 876 | 816 | 744 |
| | | Current / A | 1.73 | 1.71 | 1.70 | 1.70 | 1.68 | 1.67 | 1.66 | 1.66 | 1.65 | 1.64 | 1.63 |
| | | Power / W | 357 | 353 | 347 | 341 | 335 | 328 | 321 | 320 | 316 | 309 | 301 |
| | Lo | CFM | 989 | 952 | 915 | 876 | 834 | 795 | 751 | 737 | 700 | 648 | 585 |
| | | Current / A | 1.54 | 1.53 | 1.52 | 1.51 | 1.50 | 1.49 | 1.48 | 1.47 | 1.47 | 1.45 | 1.44 |
| | | Power / W | 314 | 306 | 300 | 293 | 286 | 281 | 274 | 273 | 267 | 259 | 252 |
| 36 | Hi | CFM | 1356 | 1308 | 1256 | 1206 | 1152 | 1096 | 1036 | 1022 | 974 | 938 | 874 |
| | | Current / A | 2.32 | 2.30 | 2.29 | 2.28 | 2.27 | 2.25 | 2.24 | 2.23 | 2.22 | 2.20 | 2.19 |
| | | Power / W | 465 | 454 | 447 | 440 | 433 | 424 | 417 | 413 | 407 | 400 | 392 |
| | Mi | CFM | 1221 | 1165 | 1122 | 1078 | 1028 | 982 | 930 | 919 | 876 | 816 | 744 |
| | | Current / A | 1.73 | 1.71 | 1.70 | 1.70 | 1.68 | 1.67 | 1.66 | 1.66 | 1.65 | 1.64 | 1.63 |
| | | Power / W | 357 | 353 | 347 | 341 | 335 | 328 | 321 | 320 | 316 | 309 | 301 |
| | Lo | CFM | 989 | 952 | 915 | 876 | 834 | 795 | 751 | 737 | 700 | 648 | 585 |
| | | Current / A | 1.54 | 1.53 | 1.52 | 1.51 | 1.50 | 1.49 | 1.48 | 1.47 | 1.47 | 1.45 | 1.44 |
| | | Power / W | 314 | 306 | 300 | 293 | 286 | 281 | 274 | 273 | 267 | 259 | 252 |

— Shaded boxes represent airflow outside the required 300–450 cfm/ton, which are not recommended.

NOTES: Airflow based upon cooling performance at 230V with no electric heat and no filter.

The air distribution system has the greatest effect on airflow. The duct system is totally controlled by the contractor. For this reason, the contractor should use only industry-recognized procedures.

Heat pump systems require a specified airflow for electric heat operating. Each ton of cooling requires between 350 and 450 cubic feet of air per minute (CFM), or 400 CFM nominally.

Duct design and construction should be carefully done. System performance can be lowered dramatically through bad planning or workmanship.

Air supply diffusers must be selected and located carefully. They must be sized and positioned to deliver treated air along the perimeter of the space. If they are too small for their intended airflow, they become noisy. If they are not located properly, they cause drafts. Return air grilles must be properly sized to carry air back to the blower. If they are too small, they also cause noise.

The installers should balance the air distribution system to ensure proper quiet airflow to all rooms in the home. This ensures a comfortable living space.

An air velocity meter or airflow hood can be used to balance and verify branch and system airflow (CFM).

4 DUCTWORK

Field ductwork must comply with the National Fire Protection Association NFPA 90A, NFPA 90B and any applicable local ordinance.

DANGER

Do not, under any circumstances, connect return ductwork to any other heat producing device such as fireplace insert, stove, etc. Unauthorized use of such devices may result in fire, carbon monoxide poisoning, explosion, personal injury or property damage.

Sheet metal ductwork in unconditioned spaces must be insulated and covered with a vapor barrier. Fibrous ductwork may be used if constructed and installed in accordance with SMACNA Construction Standard on Fibrous Glass Ducts. Ductwork must comply with National Fire Protection Association as tested by UL Standard 181 for Class I Air Ducts. Check local codes for requirements on ductwork and insulation.

- The duct system must be designed to operate within the range of external static pressure specified for the unit. It is crucial to ensure that the system airflow is adequate. Take into account the total resistance caused by supply and return ductwork, grills, special filters, accessories, etc. Please refer to the airflow performance tables provided in this manual.
- Design the duct system in accordance with “ACCA” Manual “D” Design for Residential Winter and Summer Air Conditioning and Equipment Selection. Latest editions are available from: “ACCA” Air Conditioning Contractors of America, 1513 16th Street, N.W., Washington, D.C. 20036. If duct system incorporates flexible air duct, be sure pressure drop information (straight length plus all turns) shown in “ACCA” Manual “D” is accounted for in the system.
- Supply plenum is attached to the 3/4” duct flanges supplied with the unit. Attach flanges around the blower outlet.

IMPORTANT: If an elbow is included in the plenum close to the unit, it can not be smaller than the dimensions of the supply duct flange on the unit.

IMPORTANT: If the front flange on the return duct is connected to the blower casing, it should not be screwed into the area where the power wiring is located. Drills or sharp screw points can damage insulation on wires located inside unit.

- Secure the supply and return ductwork to the unit flanges, using proper fasteners for the type of duct used and tape the duct-to-unit joint as required to prevent air leaks.

WARNING

If appliances connected via an air duct system to one or more rooms are installed in a room with an area less than shown in section 3.4 Table 5-3, that room shall be without continuously operating open flames (e.g. an operating gas appliance) or other potential ignition sources (for e.g. an operating electric heater, hot surfaces). A flame-producing device may be installed in the same space if the device is provided with an effective flame arrest.

For appliances connected via an air duct system to one or more rooms, auxiliary devices which may be a potential ignition source shall not be installed in the duct work. Examples of such potential ignition sources are hot surfaces with a temperature exceeding 700 °C and electric switching devices.

For appliances connected via an air duct system to one or more rooms, only auxiliary devices approved by the appliance manufacturer or declared suitable with the refrigerant shall be installed in connecting ductwork.

5 INSTALLATION OF ELECTRIC AUXILIARY HEAT MODULE (ONLY FOR HEAT FUNCTION MODELS)

NOTICE

Installation must be performed by an licensed contractor. Please make necessary precaution when performing the installation operation.

Accessories

| Name | Quantity | Name | Quantity |
|-------------|----------|---|----------|
| Manual | 2 | Silicone breaker cover | 1 |
| Foam gasket | 1 | Electric auxiliary heating wiring diagram | 1 |
| Screws | 7 | Circuit breaker label | 1 |

Model size selection

For installations requiring supplemental heating, the optional Electric Auxiliary Heat Module is available in sizes from 5kW to 10kW to accommodate appropriate sizing given the specific heat load and electrical requirements of each installation. Please refer to the table below for selection of available sizes of each model, being sure to avoid improper matching.

| MODEL (Btu/h) | | 5kW | 8kW | 10kW |
|---------------|---|-----|-----|------|
| 18K | - | Y | Y | Y |
| 24K | - | Y | Y | Y |
| 30K | - | Y | Y | Y |
| 36K | - | Y | Y | Y |

NOTICE

Only use matched modules certified for use with model. Please refer to the Electric Auxiliary Heat Model specification for additional details to ensure proper selection and installation.

Preparations for Installation

Before installation, please confirm the electric auxiliary heat module and supplied accessories are complete and free of any damage. Do not attempt to install if damage is present.

Electric Auxiliary Heat Module installation and Wiring Operation

Step 1
Open the upper cover.

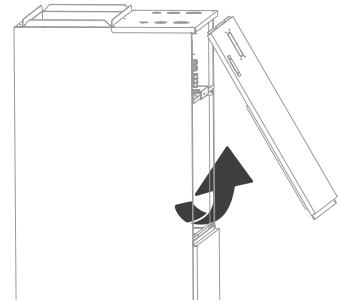

Step 2
Use tools to remove the knock-out holes of upper cover.

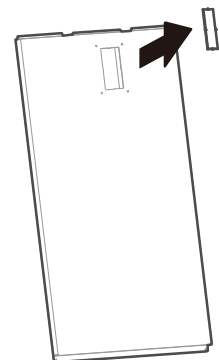

Step 3

Remove the terminal block and power wires, loosen the screws, and remove the electric auxiliary heating cover.

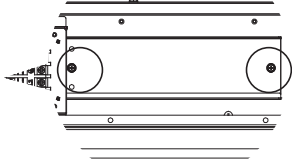

Step 5

Tighten the mounting screws.

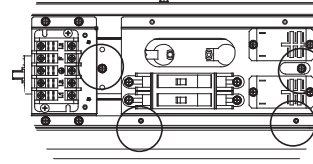

Step 4

Install the electric auxiliary heating assembly the front, and note that the support assembly must lock into the support holes in the back of the cabinet.

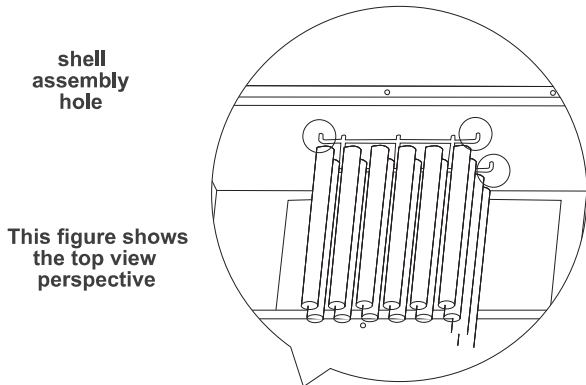

Step 6

Wire according to the wiring nameplate. Apply the wiring diagram to the inside cover wiring is completed for future reference and maintenance.

Step 7

Install the upper cover, and the silicone breaker cover.

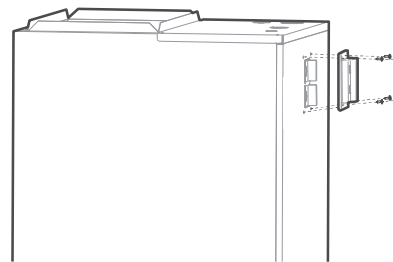

After installing the electric auxiliary heat module, apply the circuit breaker label near the silicone breaker cover that was just applied.

6 CONFIRMATION OF INDOOR UNIT

NOTICE

Electric auxiliary heating wiring diagram packed with the accessories.
 If branch circuit wire length exceeds 100 ft, consult NEC 210-19a to determine maximum wire length.
 Use 2% voltage drop.

After the electric heating wiring is connected, please confirm before power on:

- Check all wiring and ensure secure connection of all wiring.
- Ensure that wire size is properly selected per NEC or local codes.

| Specification | Number of circuit breakers | Number of relays | Number of power cord groups | Number of power cord grounding screws |
|---------------|----------------------------|------------------|-----------------------------|---------------------------------------|
| 5kW | 1 | 1 | 2 | 2 |
| 8kW | 1 | 2 | 2 | 2 |
| 10kW | 1 | 2 | 2 | 2 |

Units without electrical heat

| UNIT SIZE | VOLTS-PHASE | Rated current(A) | MIN CKT AMPS | BRANCH CIRCUIT | |
|-----------|-------------|------------------|--------------|--------------------|-------------------|
| | | | | MIN WIRE SIZE AWG* | FUSE/CKT BKR AMPS |
| 18K | 208/230-1 | 2.6 | 3.5 | 14# | 6.0 |
| 24K | 208/230-1 | 2.6 | 3.5 | 14# | 6.0 |
| 30K | 208/230-1 | 3.6 | 5.0 | 14# | 6.0 |
| 36K | 208/230-1 | 3.6 | 5.0 | 14# | 6.0 |

Use copper wire only to connect unit. If other than uncoated (non-plated) 75°C copper wire (solid wire for 10 AWG and smaller, stranded wire for larger than 10 AWG) is used consult applicable tables of the National Electric Code (ANSI/NFPA 70).

NOTICE

The specification may be different between different models, please refer to indoor unit's nameplate. Choose the cable type according to the local electrical codes and regulations. Please choose the right cable size according to the Minimum Circuit Ampacity indicated on the nameplate of the unit.

Auxiliary Heater Electrical Date

| MODEL | kW 208/240 | HEATER KIT FLA(A) | MIN CKT AMPS(A) | RATING OF OVERCURRENT PROTECTIVE DEVICE OR HACR BREAKER(A) |
|---------|---------------|----------------------|--------------------|--|
| EHK-05D | 3.8/5 | 18.2/20.8 | 23/26 | 25/30 |
| EHK-08D | 5.6/7.5 | 27.9/31.9 | 35/40 | 35/40 |
| EHK-10D | 7.5/10 | 36.3/41.7 | 46/53 | 50/60 |

Electric auxiliary heating wiring diagram

5KW HEAT KIT

: THERMAL CUT-OUT(Cut-off temperature 98°C, holding temperature 83°C, limiting temperature 410°C.)
 : THERMAL LINK, SELF-RESETTING(Break-off temperature 60 ± 3°C, reset temperature 43 ± 6°C.)

NOTE1: This symbol indicates the element is optional. The wiring type of the actual unit shall prevail.

NOTE2: Please attach the nameplate to the cover of the electric control box. All the round holes located on the plate represent numbers. Please refer to the Installation Manual for details.

| Round hole number | Relay number | Round hole number | Circuit breaker number |
|-------------------|--------------|-------------------|------------------------|
| ○ | RELAY1 | ○ | CB1 |
| ○ | | | |
| ○ | | | |
| ○ | | | |

NOTE3: TO BE WIRED IN ACCORDANCE WITH NEC AND LOCAL CODES.
NOTE4: POWER A,B,C,D ARE DIFFERENT POWERS.

The wiring mode of power supply A shall be based on the type of original wiring terminal of AHU; for type A, S position must be connected to the outdoor S; for type B, S position shall not be connected.

8KW/10KW HEAT KIT

: THERMAL CUT-OUT(Cut-off temperature 98°C, holding temperature 83°C, limiting temperature 410°C.)
 : THERMAL LINK, SELF-RESETTING(Break-off temperature 60 ± 3°C, reset temperature 43 ± 6°C.)

NOTE1: This symbol indicates the element is optional. The wiring type of the actual unit shall prevail.

NOTE2: Please attach the nameplate to the cover of the electric control box. All the round holes located on the plate represent numbers. Please refer to the Installation Manual for details.

| Round hole number | Relay number | Round hole number | Circuit breaker number |
|-------------------|--------------|-------------------|------------------------|
| ○ | RELAY1 | ○ | CB1 |
| ○ | RELAY2 | ○ | |
| ○ | | | |
| ○ | | | |

NOTE3: TO BE WIRED IN ACCORDANCE WITH NEC AND LOCAL CODES.
NOTE4: POWER A,B,C,D ARE DIFFERENT POWERS.

The wiring mode of power supply A shall be based on the type of original wiring terminal of AHU; for type A, S position must be connected to the outdoor S; for type B, S position shall not be connected.

WIRING PRECAUTIONS

⚠ WARNING

BEFORE PERFORMING ANY ELECTRICAL WORK, READ THESE WARNINGS.

- All wiring must comply with local and national electrical codes, regulations and must be installed by a licensed electrician.
- All electrical connections must be made according to the Electrical Connection Diagram located on the panels of the indoor and outdoor units.
- If there is a serious safety issue with the power supply, stop work immediately. Explain your reasoning to the client, and refuse to install the unit until the safety issue is properly resolved.
- Power voltage should be within 90-110% of rated voltage. Insufficient power supply can cause malfunction, electrical shock, or fire.
- Installation of an external surge suppressor at the outdoor disconnect is recommended.
- If connecting power to fixed wiring, a switch or circuit breaker that disconnects all poles and has a contact separation of at least 1/8in (3mm) must be incorporated in the fixed wiring. The qualified technician must use an approved circuit breaker or switch.
- Only connect the unit to an individual branch circuit. Do not connect another appliance to that Circuit.
- Make sure to properly ground the air conditioner.
- Every wire must be firmly connected. Loose wiring can cause the terminal to overheat, resulting in product malfunction and possible \boxtimes re.
- Do not let wires touch or rest against refrigerant tubing, the compressor, or any moving parts within the unit.
- To avoid getting an electric shock, never touch the electrical components soon after the power supply has been turned off. After turning off the power, always wait 10 minutes or more before you touch the electrical components.
- Make sure that you do not cross your electrical wiring with your signal wiring. This may cause distortion, interference or possibly damage to circuit boards.
- No other equipment should be connected to the same power circuit.
- Connect the outdoor wires before connecting the indoor wires.

⚠ WARNING

BEFORE PERFORMING ANY ELECTRICAL OR WIRING WORK, TURN OFF THE MAIN POWER TO THE SYSTEM.

Wiring overview

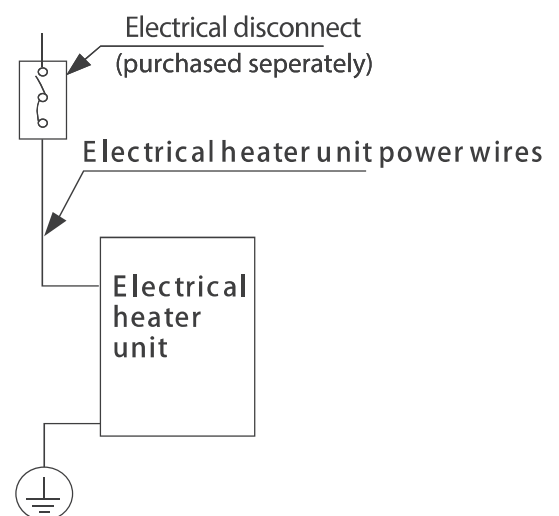
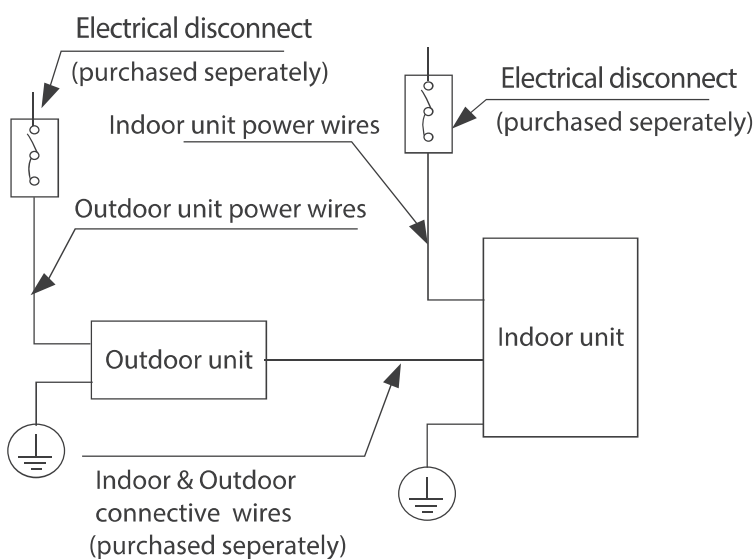

💡 NOTICE

The diagrams are for explanation purpose only. Your machine may be slightly different. The actual diagram shall prevail.

7 INDOOR UNIT WIRING

⚠ CAUTION

- While connecting the wires, please strictly follow the wiring diagram.
- The refrigerant circuit can become very hot. Keep the interconnection cable away from the copper tube.
- The appliance shall be installed in accordance with national wiring regulations

Step 1: Prepare the cable for connection.

1. Using wire strippers, strip the insulating jacket from both ends of the signal cable to reveal about 15cm (5.9") of the wire.
2. Strip the insulation from the ends of the wires.

Step 2: Open the front panel of the indoor unit.

Using a screwdriver, remove the cover of the electric control box on your indoor unit.

Step 3: Connect the wires to the terminals.

1. Thread the power cable and the signal cable through the wire outlet
2. Match the wire colors/labels with the labels on the terminal block. Firmly screw the wires of each wire to its corresponding terminal. Refer to the Serial Number and Wiring Diagram located on the cover of the electric control box.

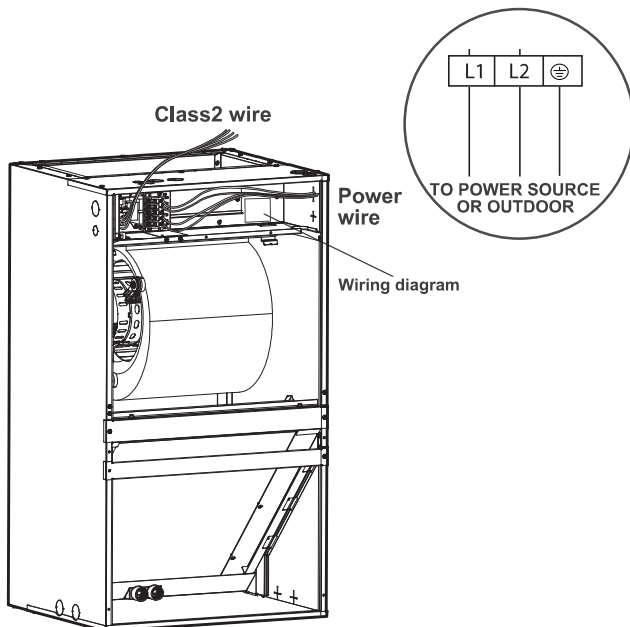

⚠ WARNING

ISOLATE THE POWER SUPPLY LEADS AND COMMUNICATION LEADS BY THE STRAIN RELIF AND KEEP POWER SUPPLY LEADS AWAY FROM COMMUNICATION LEADS.

HIGH VOLTAGE AND LOW VOLTAGE ELECTRICITY NEED TO BE SEPARATED BY SEPARATE CONDUIT

3. Clamp down the cable with the cable clamp. The cable must not be loose or pull on the u-lugs.
4. Reattach the electric box cover.
5. Clamp down the cable with the cable clamp. The cable must not be loose or pull on the u-lugs.
6. Reattach the electric box cover

⚠ CAUTION

- While connecting the wires, please strictly follow the wiring diagram.
- The refrigerant circuit can become very hot. Keep the interconnection cable away from the copper tube.

If you need to install the buzzer When the refrigerant leaks, the buzzer will receive the signal and respond in time. When the refrigerant concentration reaches the threshold, the indoor airflow will run at the highest gear and the outdoor unit will stop.

8 SPECIFIC WIRING METHODS

⚠ WARNING

Please refer to the wiring nameplate for the wiring method. Do not connect the power cord to the communication line, as this may damage the system.

When using a 24v thermostat, please refer to the non-communicating wiring diagrams that follow:

8.1 Connection method

The following wiring diagram are suitable for the AHU and ODU with 24V thermostat.

No Heat Pump System Model

Wiring for 1H and 1C thermostat (no heat pump system model)

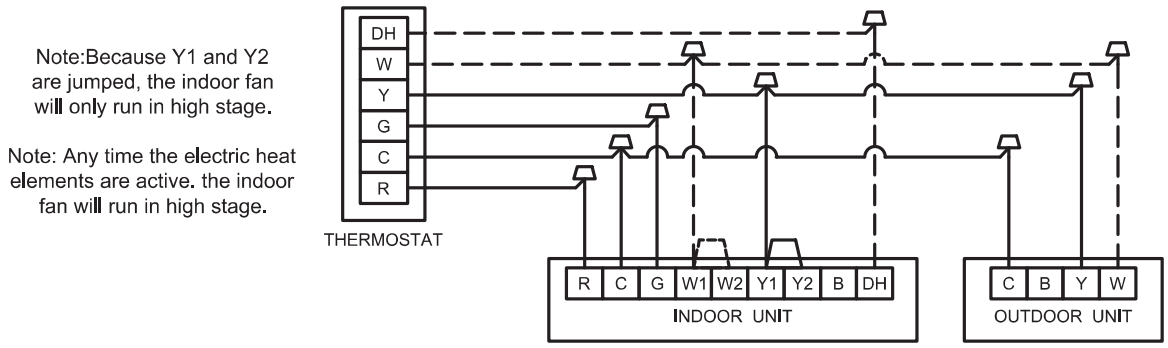

Wiring for 1H and 1C thermostat (no heat pump system model)

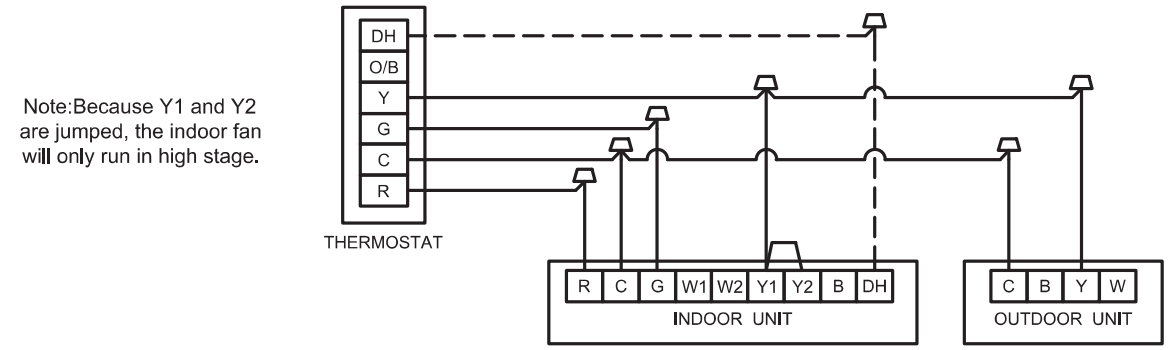

Wiring for 2H and 1C thermostat (no heat pump system model)

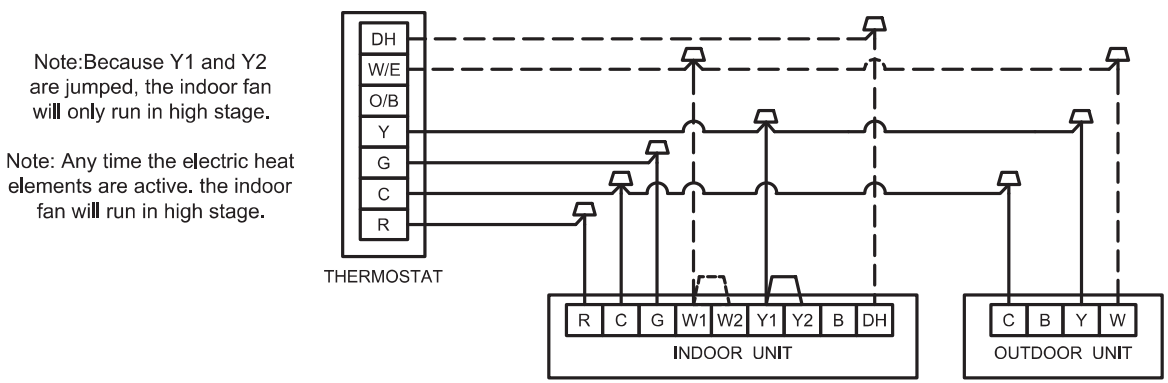

Wiring for 2H and 2C thermostat (no heat pump system model)

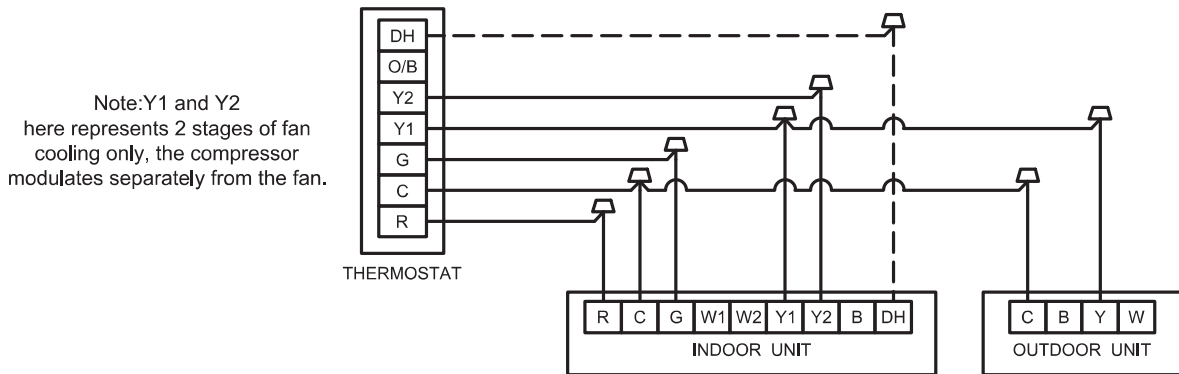

Wiring for 3H and 1C thermostat (no heat pump system model)

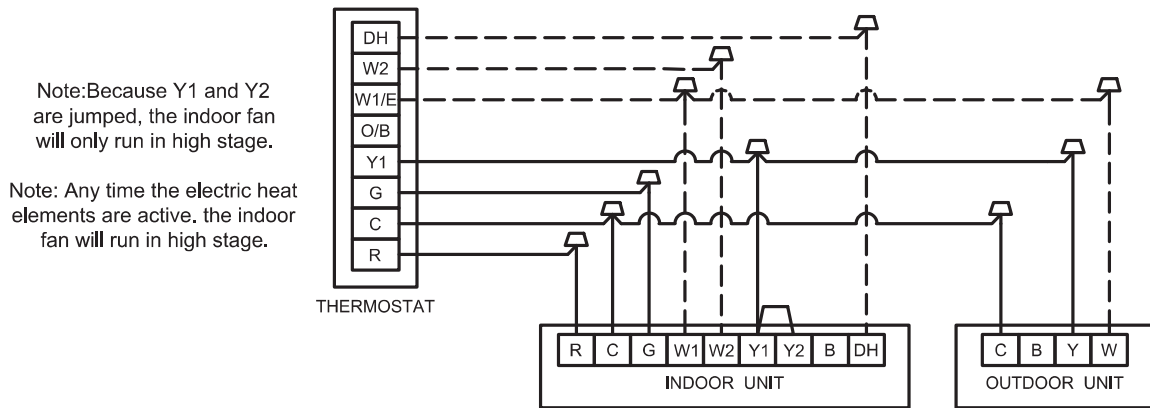

Wiring for 3H and 2C thermostat (no heat pump system model)

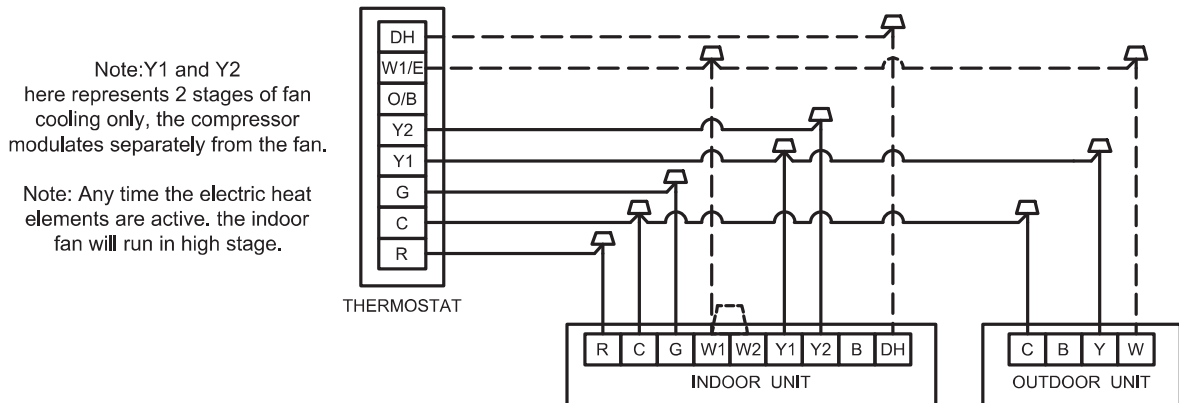

Wiring for 4H and 2C thermostat (no heat pump system model)

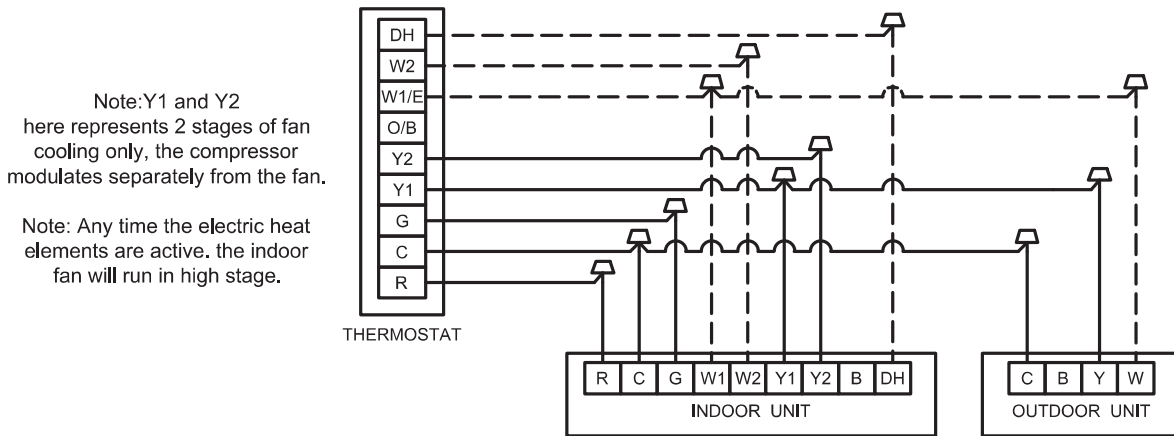

Heat Pump System Model

Wiring for 1H and 1C thermostat (heat pump system model)

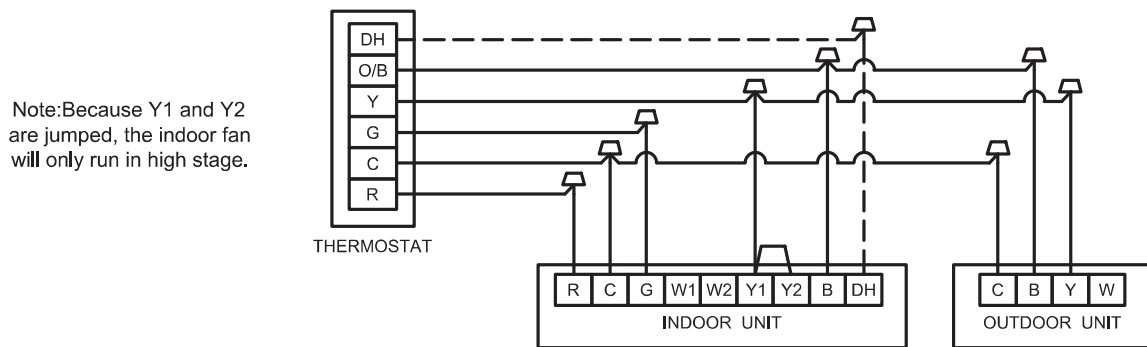

Wiring for 2H and 1C thermostat (heat pump system model)

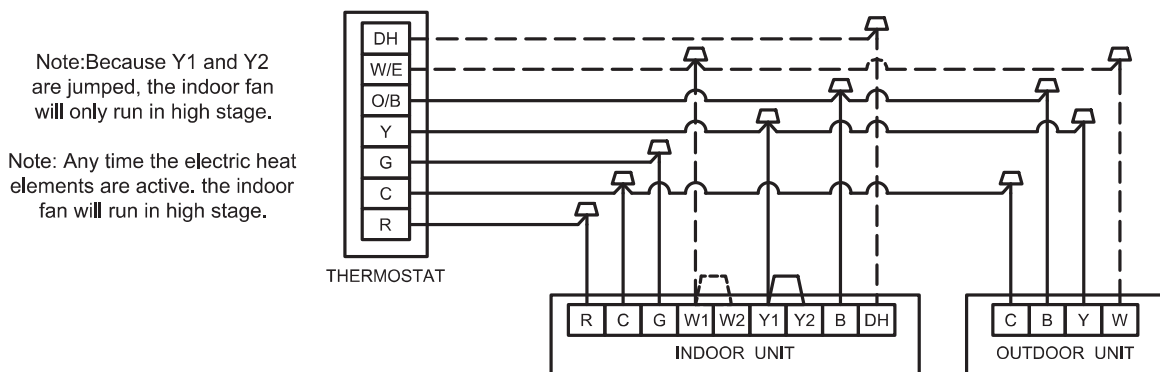

Wiring for 2H and 2C thermostat (heat pump system model)

Note: Y1 and Y2 here represents 2 stages of fan cooling only, the compressor modulates separately from the fan.

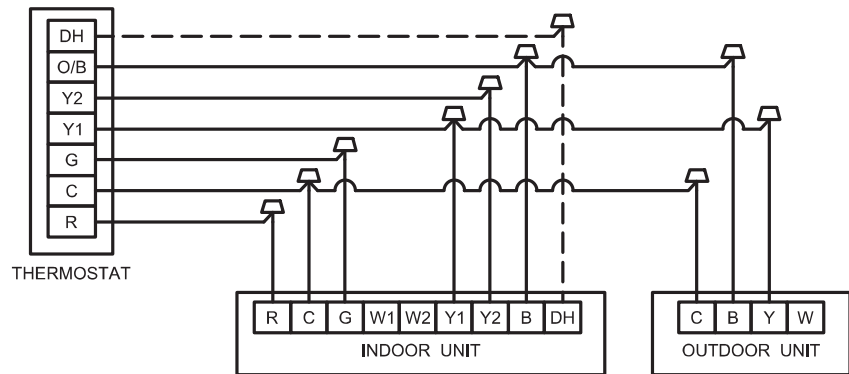

Wiring for 3H and 1C thermostat (heat pump system model)

Note: Because Y1 and Y2 are jumped, the indoor fan will only run in high stage.
 Note: Any time the electric heat elements are active, the indoor fan will run in high stage.

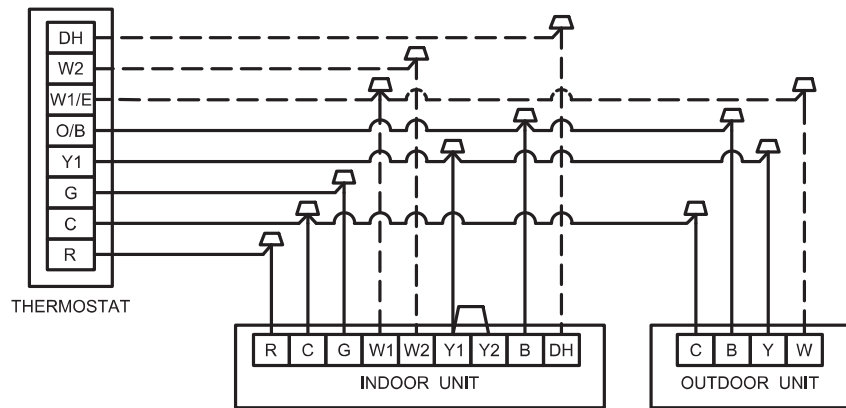

Wiring for 3H and 2C thermostat (heat pump system model)

Note: Y1 and Y2 here represents 2 stages of fan cooling only, the compressor modulates separately from the fan.

Note: Any time the electric heat elements are active, the indoor fan will run in high stage.

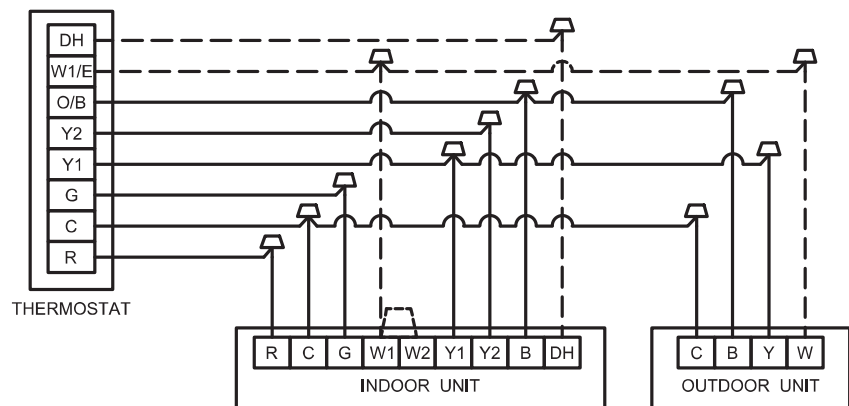

Wiring for 4H and 2C thermostat (heat pump system model)

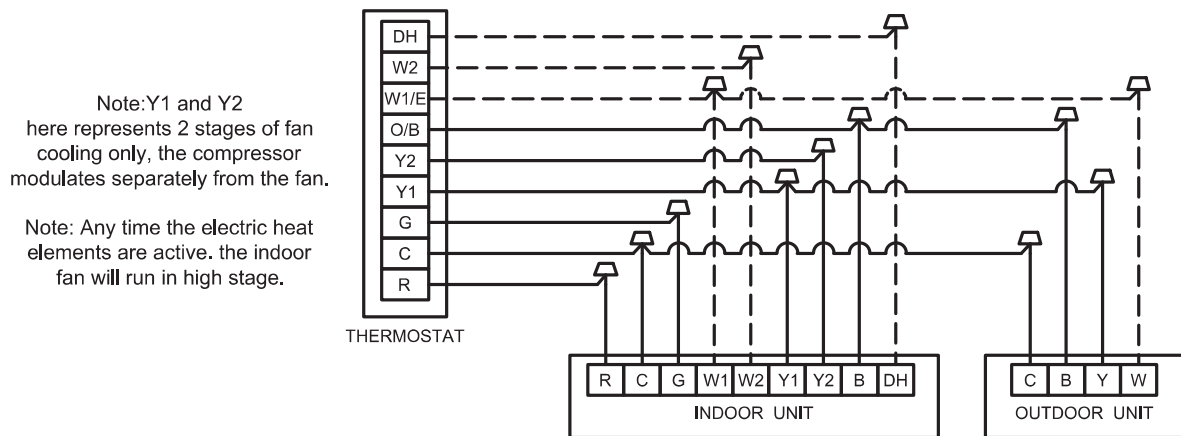

i Dh wiring is optional and requires a thermostat with a humidistat. Dh functions as Passive Dehumidification and will downstage the indoor fan to first stage. System will operate according to normal sequence of operations if Dh wiring is absent.

i Dashed lines in the above thermostat wiring diagrams refer to optional wiring (wiring for Passive Dehumidification Function and/OR Electric Heat). For thermostat wiring please refer to the Owner's Manual of the thermostat.

i B wire must be used with heat pump system only, the reversing valve energizes in heating.

Control logic

Indoor unit connector

| Connector | Purpose |
|-----------|--------------------------|
| R | 24V Power Connection |
| C | Common |
| G | Fan Control |
| Y1 | Low Cooling |
| Y2 | High Cooling |
| B | Heating Reversing Valve |
| W1 | Stage 1 Electric Heating |
| W2 | Stage 2 Electric Heating |
| DH | Dehumidification |

Outdoor unit connector

| Connector | Purpose |
|-----------|-------------------------|
| C | Common |
| Y | Cooling |
| B | Heating Reversing Valve |
| W | Heating control |

Low Voltage Maximum Wire Length

Table defines the maximum total length of low voltage wiring from the outdoor unit to the indoor unit and to the thermostat.

| 24 Volts - Wire size | Max. Wire Length |
|----------------------|------------------|
| 18 AWG | 150 Ft. |
| 16 AWG | 225 Ft. |
| 14 AWG | 300 Ft. |

Table

8.2 Self diagnosis function Error code table (indoor unit display)

| Error code | Error definition |
|------------------------------------|--|
| Flash for 2 times every 8 seconds | T1 temperature sensor fault |
| Flash for 3 times every 8 seconds | T2 temperature sensor fault |
| Flash for 4 times every 8 seconds | R32 refrigerant concentration sensor fault |
| Flash for 5 times every 8 seconds | R32 refrigerant leakage detector fault |
| Flash for 6 times every 8 seconds | Anti-freeze protection |
| Flash for 7 times every 8 seconds | Indoor unit EEPROM fault (not display on the wired controller) |
| Flash for 8 times every 8 seconds | Indoor fan motor fault |
| Flash for 9 times every 8 seconds | Communication error between outdoor and indoor unit |
| Flash for 10 times every 8 seconds | Wired controller communication error |

Note: In normal operation, the red power indicator is steady on, the green indicator is steady on; when the system is standby, the red power indicator will be steady on, the green indicator will flash slowly.

8.3 Wiring Diagrams--AC fan

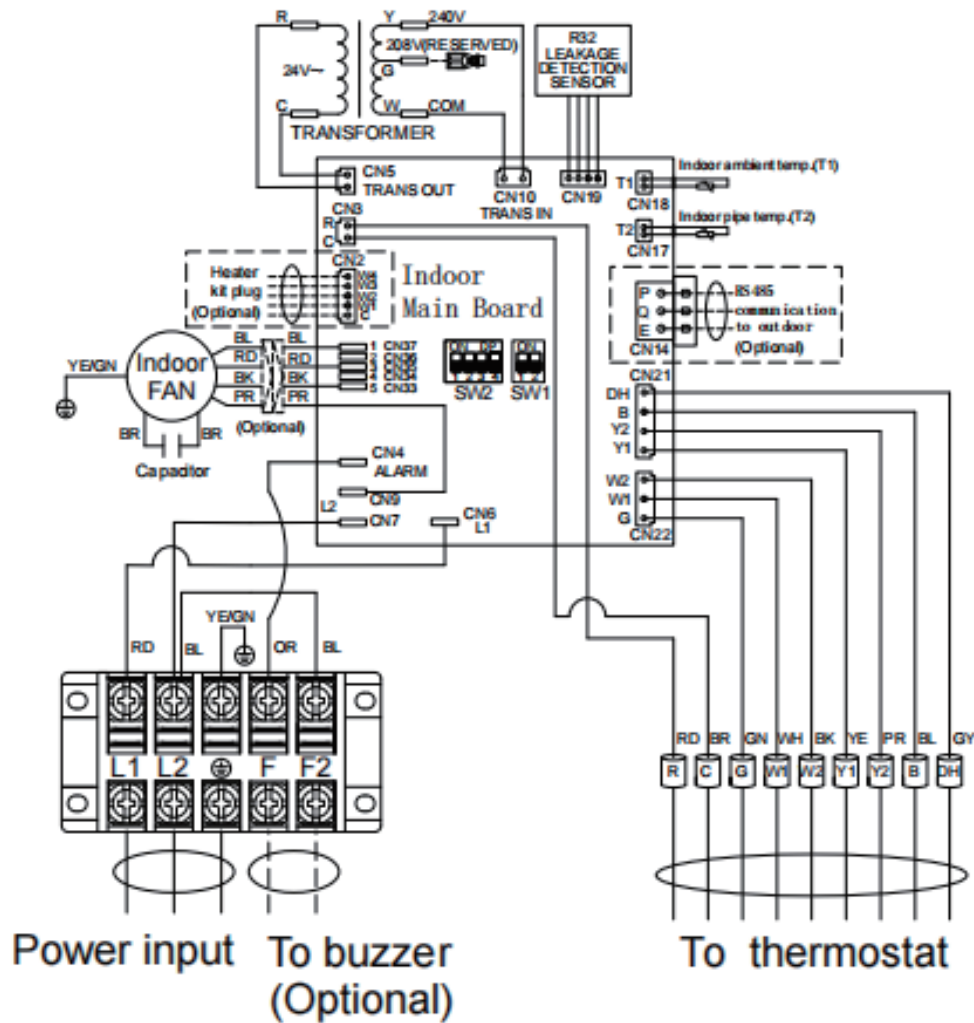

| DIP switch status Indicate | |
|---|---|
| ON <input type="checkbox"/> | This Indicate OFF (The DIP switch is dialed to the digital side) |
| OFF <input checked="" type="checkbox"/> | |
| ON <input checked="" type="checkbox"/> | This Indicate ON (The DIP switch is dialed to the non-digital side) |
| OFF <input type="checkbox"/> | |

| SW1 DIP switch selection (Indoor FAN speed) | | | |
|--|-------|----------------------------|------------------------|
| SW1.1 | SW1.2 | High speed (Y1+Y2 OR W) | Low speed (Y1 OR G) |
| OFF | OFF | 2 | 1 |
| OFF | ON | 3 | 1 |
| ON | OFF | 4 | 1 |
| ON | ON | 5(Default) | 1(Default) |

| SW2 DIP switch selection | | |
|--------------------------|-----|------------------------------|
| SW2.1 | OFF | 24V Control(Default) |
| | ON | RS485 Comm. Mode |
| SW2.2 | OFF | Anti-Cold Air Delay(Default) |
| | ON | Disable Anti-Cold Air Delay |
| SW2.3 | OFF | T1 from main board(Default) |
| | ON | T1 from thermostat |
| SW2.4 | OFF | Indoor AC FAN(Default) |
| | ON | Indoor ECM FAN |

| Wire Color Code | | | |
|-----------------|-------|----|--------|
| RD | RED | OR | ORANGE |
| BL | BLUE | GN | GREEN |
| BR | BROWN | GY | GRAY |
| BK | BLACK | YE | YELLOW |
| WH | WHITE | PR | PURPLE |

9 MAINTENANCE



In order to keep high performance and minimize possible equipment failures, the equipment must be regularly maintained.

9.1 Cleaning Precautions



Warning:

- Any equipment maintenance can only be carried out by qualified maintenance personnel.



Warning: Before cleaning and maintenance

- Before cleaning or maintenance, be sure to turn off the equipment and disconnect its power supply.



Be careful:

- When removing the filter, do not touch the metal parts in the device. Sharp metal edges can cut you.



Note:

- Do not use chemicals or chemically treated cloth to clean the equipment.
- Do not use benzene, paint thinner, polishing powder or other solvents to clean this machine.
- Do not operate the system without a filter.

9.2 Routine Maintenance

Your equipment must be inspected regularly by qualified service technicians. Your annual system check must include:

1. Check the filter every 90 days, or at any time as needed. If it is blocked or block, please clean or replace it immediately.
2. Inspection and/or cleaning of impeller housing and motor.
3. Check and clean indoor and outdoor coils as needed.
4. Check and/or clean indoor coil drain pan and drain pipe and auxiliary drain pan and pipe.
5. Check all wires and connections. Refer to the wiring diagram and make corrections as needed.

ComfortStar®

Air Conditioning & Heating Products

The design and specifications are subject to change without prior notice for product improvement. Consult with the sales agency or manufacturer for details. Any updates to the manual will be uploaded to the service website, please check for the latest version.