

Service Manual

CPH7 SERIES

CPH7-24-15 (30L)
CPH7-30-15 (30M)
CPH7-36-15 (30N)
CPH7-42-15 (30P)
CPH7-48-15 (30Q)
CPH7-60-15 (30R)



IMPORTANT NOTE:



Read this manual carefully before operating your new air conditioning unit. Make sure to save this manual for future reference.

Please check the applicable models, technical data, F-GAS(if any) and manufacturer information from the "Owner's Manual - Product Fiche " in the packaging of the outdoor unit. (European Union products only)

Safety Signs



This is the general warning sign. It is used to alert the user to potential hazards. All safety messages that follow this sign shall be obeyed to avoid possible harm.



Indicates a hazard with a high level of risk which, if not avoided, will result in death or serious injury.



Indicates a hazard with a medium level of risk which, if not avoided, could result in death or serious injury.



Indicates a hazard with a low level of risk which, if not avoided, could result in minor or moderate injury.



A situation that may cause damage to the equipment or loss of property.



Work on the refrigerant circuit with flammable refrigerant in safety group A2L may only be carried out by authorized contractors. These heating contractors must be trained in accordance with UL 60335-2-40, Section HH. The certificate of competence from an industry accredited body is required.

Work on electrical equipment may only be carried out by a qualified electrician.

Before initial commissioning, all safety – related points must be checked by the particular certified heating contractors. The system must be commissioned by the system installer or a qualified person authorized by the installer.

For installation of the unit, refer to the corresponding installation and operation manual. If an unit is installed in an unventilated area, the area shall be so constructed that should any refrigerant leak, it will not stagnate so as to create a fire or explosion hazard.

The appliance shall be stored so as to prevent mechanical damage from occurring.

Do not stack combustible materials on the surface of the unit.



Do not use means to accelerate the defrosting process or to clean, other than those recommended by the manufacturer.

The appliance shall be stored in a room that does not have continuously operating ignition sources (for example: open flames, an operating gas appliance or an operating electric heater).

Do not pierce or burn the unit.

Be aware that refrigerants may not contain an odour.

If refrigerant gas leaks during installation, ventilate the area immediately.

Comply with national gas regulations.

Safety Precautions



This appliance is not intended for use by persons (including children) with reduced physical, sensory or mental capabilities, or persons who lack experience and knowledge, unless they are supervised or have been given instructions concerning the use of the appliance by a person responsible for their safety. Children should be supervised to ensure that they do not play with the appliance.

Any person who is involved with working on or opening a refrigerant circuit should hold a current valid certificate from an industry-accredited assessment authority, which authorizes their competence to handle refrigerants safely in accordance with an industry recognized assessment credential.

Servicing shall only be performed as recommended by the equipment manufacturer.

Maintenance and repair requiring the assistance of other skilled personnel shall be carried out under the supervision of a person competent in the use of flammable refrigerants.

Prior to beginning work on systems containing flammable refrigerants, safety checks are necessary to minimize the risk of ignition.

When repairing the refrigerating system, comply with the following precautions prior to conducting work on the system:

- shall be undertaken according to controlled procedures so as to minimize the risk of the presence of flammable gases or vapors while the work is being performed.
- All maintenance staff and others working in the local area shall be instructed on the nature of work being carried out. Work in confined spaces shall be avoided.
- The area shall be checked with an appropriate refrigerant detector prior to and during work, to ensure the technician is aware of potentially toxic or flammable environment. Ensure that the leak detection equipment being used is suitable for use with all applicable refrigerants, i.e. non-sparking, adequately sealed or intrinsically safe.
- If any hot work is to be conducted on the refrigerating equipment or any associated parts, appropriate fire extinguishing equipment shall be available and easily accessible. Have a dry powder or CO₂ fire extinguisher adjacent to the charging area.
- When carrying out work in relation to a refrigerating system that involves exposing any pipe work, no sources of ignition shall be used in such a manner that it may lead to the risk of fire or explosion. All possible ignition sources, including cigarette smoking, should be kept sufficiently far away from the site of installation, repair, or removal and disposal of the unit, during which refrigerant can possibly be released into the surrounding space. Prior to beginning work, the area around the equipment is to be surveyed to make sure that there are no flammable hazards or ignition risks. “No Smoking” signs shall be clearly displayed. Ensure that the area is in the open or that it is adequately ventilated before opening the system or conducting any hot work. A degree of ventilation shall continue during the period that the work is carried out. The ventilation should safely disperse any released refrigerant and preferably expel it externally into the surroundings.

Where electrical components are being changed, they shall be fit according to their purpose and to the correct specification. At all times the manufacturer’s maintenance and service guidelines shall be followed. If in doubt, consult the manufacturer’s technical department for assistance. The following checks shall be applied to installations using flammable refrigerants:

- The actual refrigerant charge is in accordance with the room size within which the refrigerant containing parts are installed;
 - The ventilation machinery and outlets are operating adequately and are not obstructed.
 - If an indirect refrigerating circuit is being used, the secondary circuit shall be checked for the presence of refrigerant.
 - Equipment marking must remain visible and legible. Markings and signs that are illegible shall be corrected.
- Refrigerating pipe or components are installed in a position where they are unlikely to be exposed to any substances which may corrode refrigerant containing components, unless the components are constructed of materials that are inherently resistant to corrosion or are suitably protected against corrosion.
- Repair and maintenance of electrical components shall include initial safety checks and component inspection procedures. If a fault exists that could compromise safety, then no electrical supply shall be connected to the circuit until the fault has been dealt with satisfactorily.

Safety Precautions



If the fault cannot be corrected immediately but it is necessary to continue operation, an adequate temporary solution shall be used. This shall be reported to the owner of the equipment so that all parties are advised. Initial safety checks shall include:

- That capacitors are discharged: this shall be done in a safe manner to avoid the possibility of sparking;
- That no live electrical components and wiring are exposed while charging, recovering or purging the system;
- That there is continuity of earthing.

Sealed electrical components shall be replaced. Intrinsically safe components must be replaced.

Check that cabling will not be subject to wear, corrosion, excessive pressure, vibration, sharp edges or any other adverse environmental effects. The check shall also take into account the effects of aging or continual vibration from sources such as compressors or fans.

Under no circumstances shall potential sources of ignition be used while searching for or detection of refrigerant leaks. A halide torch (or any other detector using a naked flame) shall not be used.

Electronic leak detectors may be used to detect refrigerant leaks but, in the case of flammable refrigerants, the sensitivity may not be adequate, or may need re-calibration. (Detection equipment shall be calibrated in a refrigerant-free area.) Ensure that the detector is not a potential source of ignition and is suitable for the refrigerant used. Leak detection equipment shall be set at a percentage of the LFL of the refrigerant and shall be calibrated for the refrigerant employed, and the appropriate percentage of gas (25 % maximum) is confirmed.

If a leak is suspected, all naked flames shall be removed/extinguished. If a leakage of refrigerant which requires brazing is found, all of the refrigerant shall be recovered from the system, or isolated (by means of shut off valves) in a part of the system remote from the leak.

Leak detection fluids are also suitable for use with most refrigerants but the use of detergents containing chlorine shall be avoided as the chlorine may react with the refrigerant and corrode the copper pipe-work.

NOTE: Examples of leak detection fluids are

- bubble method,
- fluorescent method agents.

When breaking into the refrigerant circuit to make repairs - or for any other purpose-conventional procedures shall be used. However, for flammable refrigerants it is important that best practice be followed, since flammability is a consideration. The following procedure shall be adhered to:

- safely remove refrigerant following local and national regulations.
- evacuate.
- purge the circuit with inert gas .
- evacuate.
- continuously flush or purge with inert gas when using flame to open circuit, and.
- open the circuit.

The refrigerant charge shall be recovered into the correct recovery cylinders if venting is not allowed by local and national codes. For appliances containing flammable refrigerants, the system shall be purged with oxygen-free nitrogen to render the appliance safe for flammable refrigerants. This process might need to be repeated several times. Compressed air or oxygen shall not be used for purging refrigerant systems.

For appliances containing flammable refrigerants, refrigerants purging shall be achieved by breaking the vacuum in the system with oxygen-free nitrogen and continuing to fill until the working pressure is achieved, then venting to atmosphere, and finally pulling down to a vacuum. This process shall be repeated until no refrigerant is within the system .When the final oxygen-free nitrogen charge is used, the system shall be vented down to atmospheric pressure to enable work to take place.

The outlet for the vacuum pump shall not be close to any potential ignition sources, and ventilation shall be available.

Ensure that contamination of different refrigerants does not occur when using charging equipment. Hoses or lines shall be as short as possible to minimise the amount of refrigerant they contain.

Cylinders shall be kept upright. Ensure that the refrigeration system is grounded prior to charging the system with refrigerant.

Label the system when charging is complete (if it is not already labeled).

Take extreme care not to overfill the refrigeration system.

Safety Precautions



Prior to recharging the system, it shall be pressure-tested with the appropriate purging gas. The system shall be leak-tested on completion of charging but prior to commissioning. A follow up leak test shall be carried out prior to leaving the site.

Before carrying out this procedure, it is essential that the technician is completely familiar with the equipment and all its detail. It is recommended that all refrigerants are recovered safely. Prior to the task being carried out, an oil and refrigerant sample shall be taken in case analysis is required prior to re-use of reclaimed refrigerant. It is essential that electrical power is available before the task is commenced.

- a) Become familiar with the equipment and its operation.
- b) Isolate system electrically.
- c) Before attempting the procedure ensure that:
 - mechanical handling equipment is available, if required, for handling refrigerant cylinders;
 - all personal protective equipment is available and being used correctly;
 - the recovery process is supervised at all times by a competent person;
 - recovery equipment and cylinders conform to the appropriate standards.
- d) Pump down refrigerant system, if possible.
- e) If a vacuum is not possible, make a manifold so that refrigerant can be removed from various parts of the system.
- f) Make sure that the cylinder is situated on the scales before recovery takes place.
- g) Start the recovery machine and operate it in accordance with the manufacturer's instructions.
- h) Do not overfill cylinders. (No more than 80% volume liquid charge).
- i) Do not exceed the maximum working pressure of the cylinder, even temporarily.
- j) When the cylinders have been filled correctly and the process has been completed, make sure that the cylinders and the equipment are removed from site promptly and all isolation valves on the equipment are closed off.
- k) Recovered refrigerant shall not be charged into another refrigeration system unless it has been cleaned and checked.

Equipment shall be labeled stating that it has been de-commissioned and emptied of refrigerant. The label shall be dated and signed. Ensure that there are labels on the equipment stating the equipment contains flammable refrigerant.

When removing refrigerant from a system, either for servicing or decommissioning, it is recommended that all refrigerants are removed safely.

When transferring refrigerant into cylinders, ensure that only appropriate refrigerant recovery cylinders are employed. Ensure that the correct number of cylinders for holding the total system charge is available. All cylinders to be used are designated for the recovered refrigerant and labelled for that refrigerant (i.e. special cylinders for the recovery of refrigerant). Cylinders shall be complete with pressure-relief valve and associated shut-off valves in good working order. Empty recovery cylinders are evacuated and, if possible, cooled before recovery occurs.

The recovery equipment shall be in good working order with a set of instructions concerning the equipment that is at hand and shall be suitable for the recovery of the flammable refrigerant. If in doubt, the manufacturer should be consulted. In addition, a set of calibrated weighing scales shall be available and in good working order. Hoses shall be complete with leak-free disconnect couplings and in good condition.

The recovered refrigerant shall be processed according to local legislation in the correct recovery cylinder, and the relevant waste transfer note arranged. Do not mix refrigerants in recovery units and especially not in cylinders.

If compressors or compressor oils are to be removed, ensure that they have been evacuated to an acceptable level to make certain that flammable refrigerant does not remain within the lubricant. The compressor body shall not be heated by an open flame or other ignition sources to accelerate this process. When oil is drained from a system, it shall be carried out safely.

Do not use the air conditioner for other purposes. In order to avoid any quality deterioration, do not use the unit for the cooling of precision instruments, food, plants, animals or works of art. Before cleaning, be sure to stop the operation, turn the breaker off or unplug the supply cord. Otherwise, electric shock and injury may occur. In order to avoid electric shock or fire, make sure that an earth leak detector is installed.

Never touch the air outlet or the horizontal blades while the swing flap is in operation. Your fingers may be come caught or the unit may break down.

Safety Precautions



- Never put any objects into the air inlet or outlet.
- Objects touching the fan at high speed can be dangerous.
- Never inspect or service the unit by yourself.
- Ask a qualified service person to perform this task.
- Do not dispose of this product as unsorted municipal waste. This waste should be collected separately for special treatment. Do not dispose of electrical appliances as unsorted municipal waste. Use separate collection facilities. Contact your local government for information regarding the connection systems available.
- If electrical appliances are disposed of in landfills or dumps, hazardous substances can leak into the groundwater and get into the food chain, harming your health and well-being.
- To prevent refrigerant leak, contact your dealer. When the system is installed and operates in a small room, it is required to maintain the concentration of the refrigerant below the limit, in case a leak occurs. Otherwise, oxygen in the room may be affected, resulting in a serious accident.
- The refrigerant in the air conditioner is safe and normally does not leak.
- If the refrigerant leaks into the room and comes into contact with the fire of a burner, a heater or a cooker, a harmful gas could be released.
- Turn off any combustible heating devices, ventilate the room, and contact the dealer where you purchased the unit.
- Do not use the air conditioner until a service person confirms that the refrigerant leak is repaired.
- Keep ventilation openings clear of obstruction.
- Be sure the air conditioner is earthed.
- In order to avoid electric shock, make sure that the unit is earthed and that the earth wire is not connected to a gas or water pipe, lightning conductor or telephone earth wire.
- Do not operate the air conditioner with a wet hands. An electric shock may happen.
- Do not touch the heat exchanger fins. These fins are sharp and could cut you.
- To avoid oxygen deficiency, ventilate the room sufficiently if equipment with a burner is used together with the air conditioner.
- Arrange the drain hose to ensure smooth drainage. Incomplete drainage may cause wetting of the building, furniture, etc.
- Never touch the internal parts of the controller.
- Do not remove the blower access panel. Some parts inside are dangerous to touch, and machine troubles may occur.
- Attention is drawn to the fact that additional transportation regulations may exist with respect to equipment containing flammable gas. The maximum number of pieces of equipment or the configuration of the equipment permitted to be transported together will be determined by the applicable transport regulations.
- Signs for similar appliances used in a work area are generally addressed by local regulations and give the minimum requirements for the provision of safety and/or health signs for a work location.
- All required signs are to be maintained and employers should ensure that employees receive suitable and sufficient instruction and training on the meaning of appropriate safety signs and the actions that need to be taken in connection with these signs. The effectiveness of signs should not be diminished by too many signs being placed together. Any pictograms used should be as simple as possible and contain only essential details.
- The storage of the appliance should be in accordance with the applicable regulations or instructions, whichever is more stringent.
- Storage package protection should be constructed such a way that mechanical damage to the equipment inside the package will not cause a leak of the REFRIGERANT CHARGE.
- The maximum number of pieces of equipment permitted to be stored together will be determined by local regulations.
- Do not operate the air conditioner when using a room fumigation - type insecticide. Failure to observe this precaution could cause the chemicals to become deposited in the unit, which could endanger the health of those who are hypersensitive to chemicals. It may also cause the refrigerant sensor to alarm.
- Do not place appliances which produce open flame in places exposed to the air flow from the unit or under the unit. It may cause incomplete combustion or deformation of the unit due to the heat.
- Do not install the air conditioner in a location where flammable gas may leak out. If the gas leaks out and stays around the air conditioner, a fire may break out.

Safety Precautions

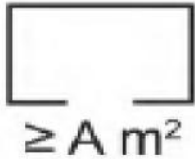

The appliance shall be installed, operated and stored in a room with a floor area not less than the minimum room area. Refer to the installation instructions for the minimum room area required to install the appliance.



The pipe-work including piping material, pipe routing, and installation shall include protection from physical damage in operation and service, and be in compliance with national and local codes and standards, such as ASHRAE 15, ASHRAE 15.2, IAPMO Uniform Mechanical Code, ICC International Mechanical Code. inspection prior to being covered or enclosed; or CSA B52. All field joints shall be accessible for inspection prior to being covered or enclosed.

All joints made in the installation between parts of the refrigerating system, with at least one part charged, shall be made in accordance with the following:

- A brazed, welded, or mechanical connection shall be made before opening the valves to permit refrigerant to flow between the refrigerating system parts. A vacuum valve shall be provided to evacuate the interconnecting pipe or any uncharged refrigerating system part.
- Mechanical connectors used indoors shall comply with ISO 14903. When mechanical connectors are reused indoors, sealing parts shall be renewed. When flared joints are reused indoors, the flare part shall be refabricated.
- Refrigerant tubing shall be protected or enclosed to avoid damage.

Compliance is checked according to the installation instructions and a trial installation, if necessary.

After completion of field piping for split systems, the field pipework shall be pressure tested with an inert gas and then vacuum tested prior to refrigerant charging, according to the following requirements.

The minimum test pressure for the low side of the system shall be the low side design pressure and the minimum test pressure for the high side of the system shall be the high side design pressure, unless the high side of the system, cannot be isolated from the low side of the system in which case the entire system shall be pressure tested to the low side design pressure.

- mechanical joints in compliance with ISO 14903 or UL 207 (U.S. only).
- welded or brazed joints.
- joints in enclosures that vent to the unit or to the outside. Compliance is checked by inspection and tests.

Components and accessories from the units are not part of ordinary domestic waste.

Complete units, compressors, motors etc. are only to be disposed of via qualified disposal specialists.

This unit uses flammable refrigerant R454B. Please contact the dealer when you want to dispose of this unit.

Law requires that the collection, transportation and disposal of refrigerants must conform with the regulations governing the collection and destruction of hydrofluorocarbons.

Safety Precautions **WARNING**

The refrigerant leakage sensor can only use the factory model or the specified model indicated in the corresponding manual.

The R454B refrigerant leakage sensor must be used to activate the refrigerant shut-off device, the alarm device, incorporated circulation airflow or other emergency controls, which shall give an electrical signal at a predetermined alarm set point in response to leaked refrigerant.

The installation of the refrigerant leakage sensor shall allow access for checking, repair or replacement by an authorized person.

The refrigerant leakage sensor shall be installed so its function can be verified easily.

The refrigerant leakage sensor shall be protected to prevent tampering or unauthorized resetting of the pre-set value.

To be effective, the refrigerant leakage sensor must be electrically powered at all times after installation, other than when servicing.

If the refrigerant leakage sensor detects a refrigerant leak, the fan will be turned on to the maximum, the compressor will stop running. you should immediately leave the leak area and notify a professional for handling.

The service life of the refrigerant sensor is 15 years, and it should be replaced after the service life.

LEAK DETECTION SYSTEM installed on unit. Unit must be powered except for service.

 **WARNING**

For appliances connected via an air duct system to one or more rooms, auxiliary devices which may be a potential ignition source shall not be installed in the duct work. Examples of such potential ignition sources are hot surfaces with a temperature exceeding 700° C and electric switching devices.

For appliances connected via an air duct system to one or more rooms, only auxiliary devices approved by the appliance manufacturer or declared suitable with the refrigerant shall be installed in connecting ductwork.

Service Manual

PART 1 Product instruction

PART 2 System Instruction.....	3
2.2 Functional Parts Layout	3
2.3 Refrigerant Flow Chart for Each Operation Mode	7
PART 3 Function and Control	8
3.1 Function General	9
PART 4 Field settings	26
4.1 Pre Operation	27
4.2 Trial Operation	33
PART 5 Intelligent Troubleshooting.....	38
5.1 Diagnosis System Introduction	39
5.2 Symptom-based Troubleshooting	41
5.3 Troubleshooting by Module board Fault code.....	44
5.4 Troubleshooting by Control board Fault code.....	54
PART 6 Check	58
6.1 Check for Causes of Rise in High Pressure	59
6.2 Check for Causes of Dropping Low Pressure in Cooling	60
6.3 Check for Causes of Dropping Low Pressure in Heating	61
6.4 Check for Causes of Refrigeration cycling Blocked	62
6.5 Check for Module Board	63
6.6 Check for Control Board	65
6.7 Check for Temperature Sensor (T3/T4)	67
6.8 Check for High Pressure Switch (HPS)	68
6.9 Check for Low Pressure Switch (LPS)	69
6.10 Check for Discharge Temperature Switch (DTS)	70
6.11 Check for Outdoor Fan Motor	71
6.12 Check for Compressor Check	72
6.13 Check for indoor PSC unit status	73
6.14 Check for indoor ECM unit status	74
6.15 Check for Outdoor fan motor Speed	75
6.16 Check for FUSE	76
PART 7 Appendix	77
7.1 Wiring Diagrams	78
7.2 Main board replacement procedure	81
7.3 Menu button Function	84
7.4 Troubleshooting Guide	85
7.5 Temperature and Resistance Relationship Tables	86
7.6 Refrigerant sensor repair and replacement guidelines separately	87
7.7 Wind pressure switch maintenance and replacement	88

2.2 Functional Part

13.4HP 71/90

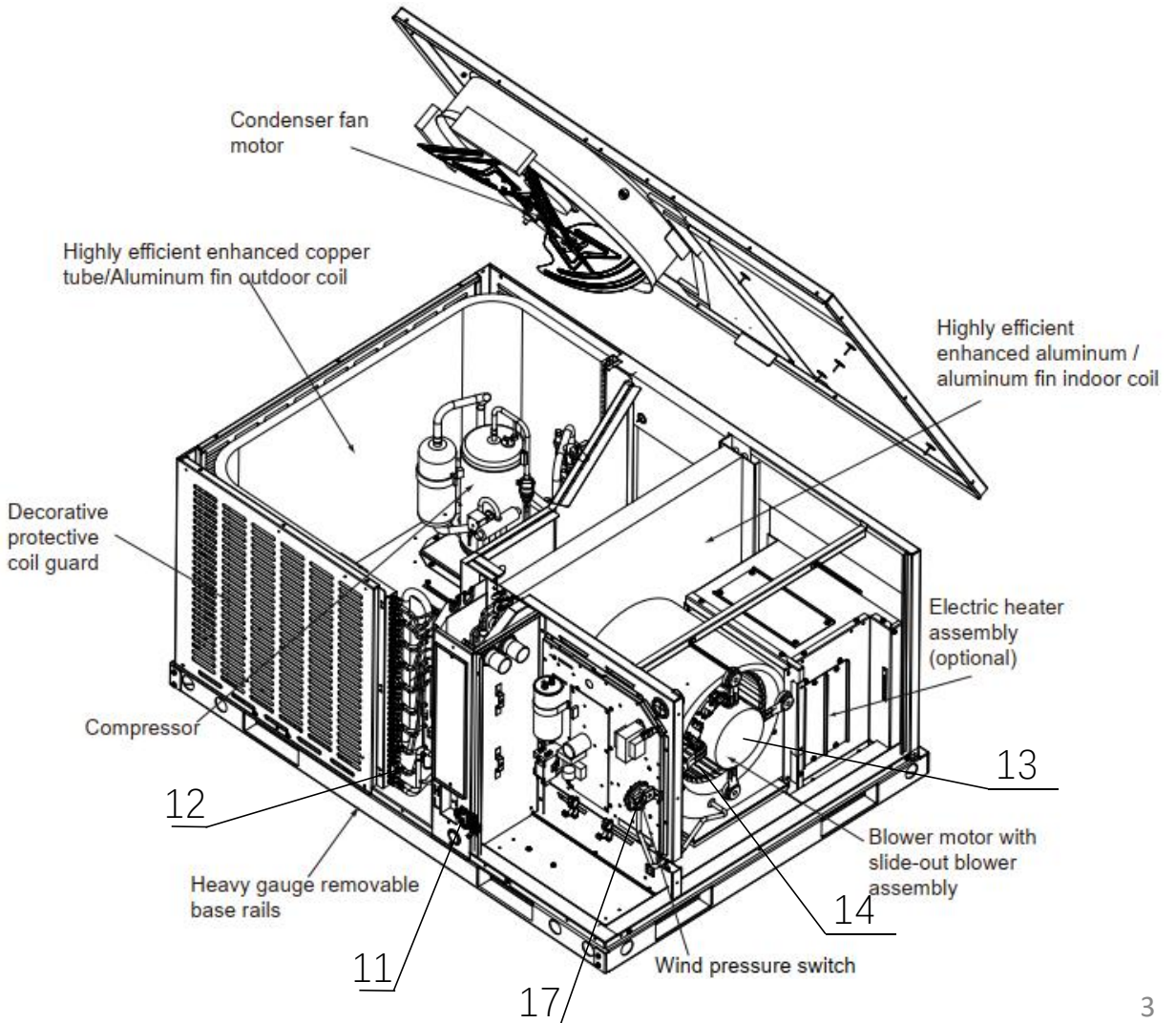
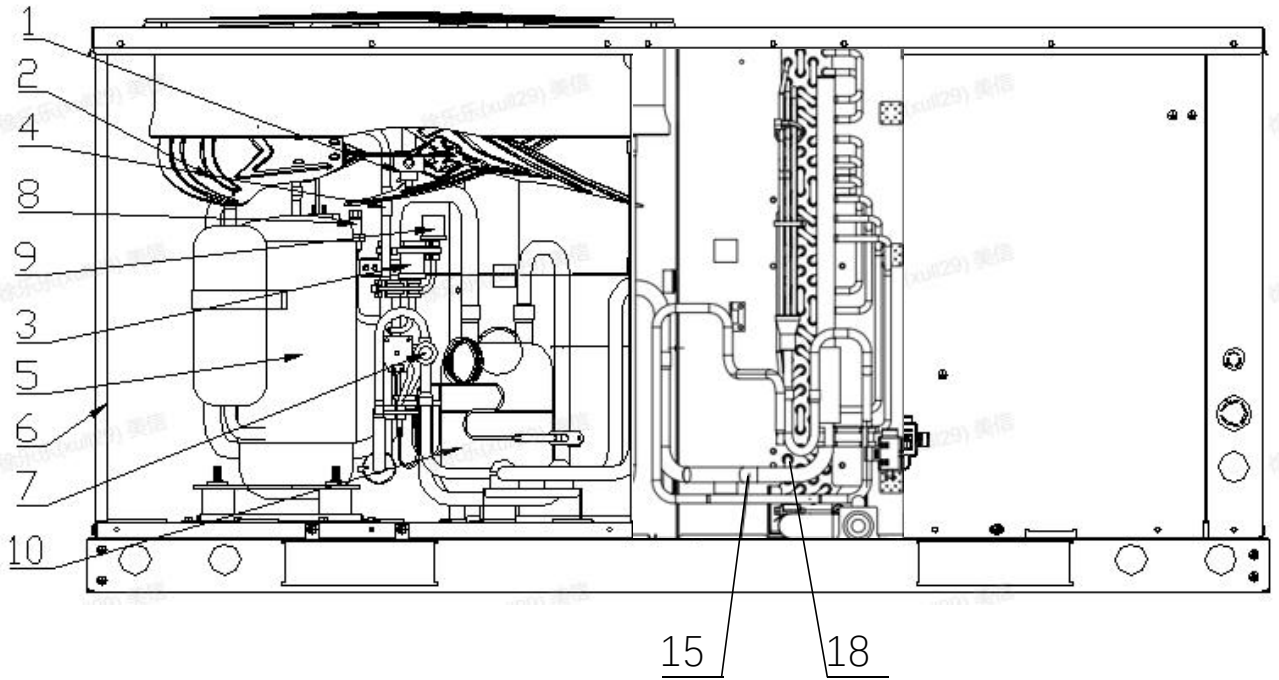

2.2 Functional Part

13.4HP 105

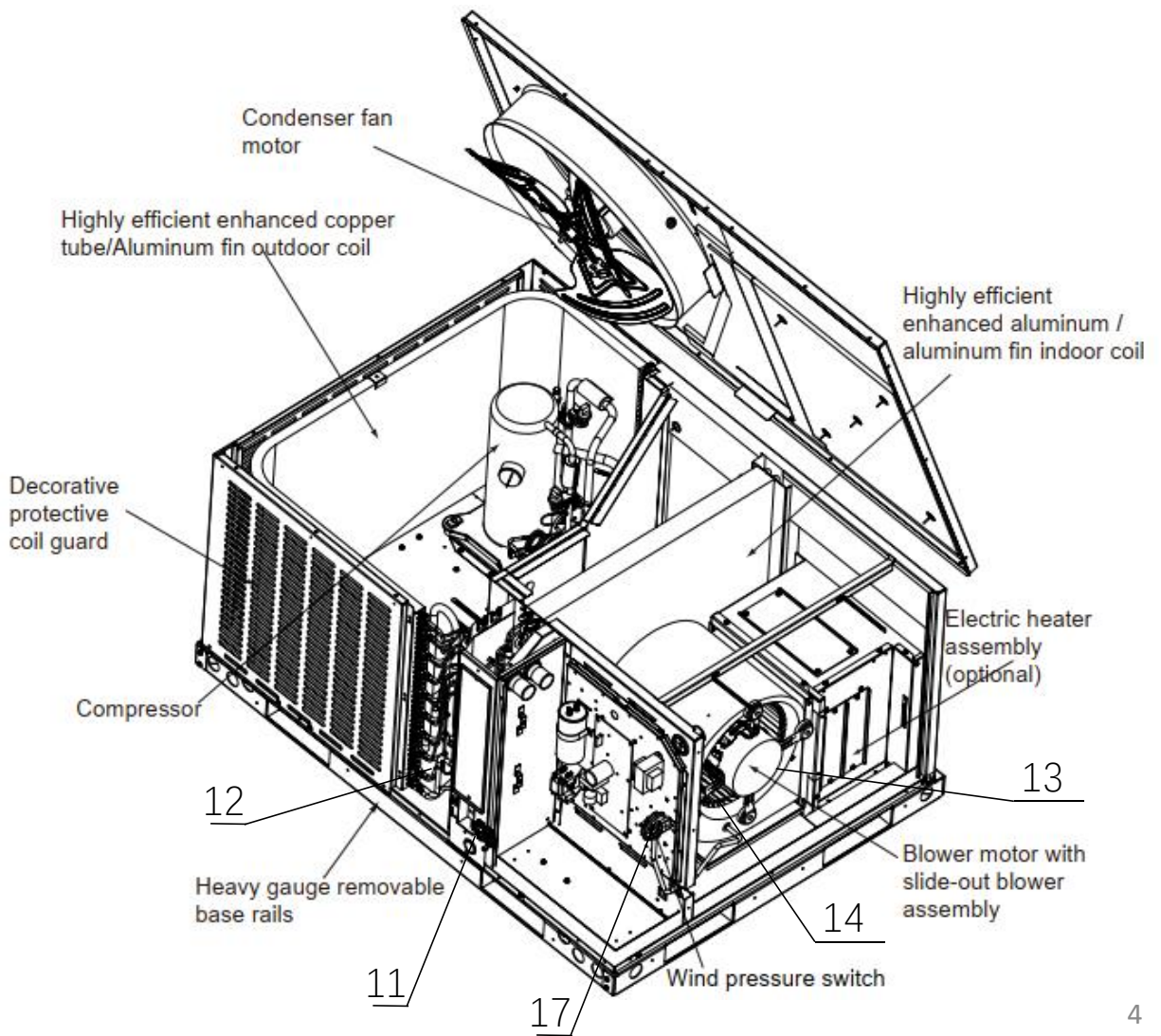
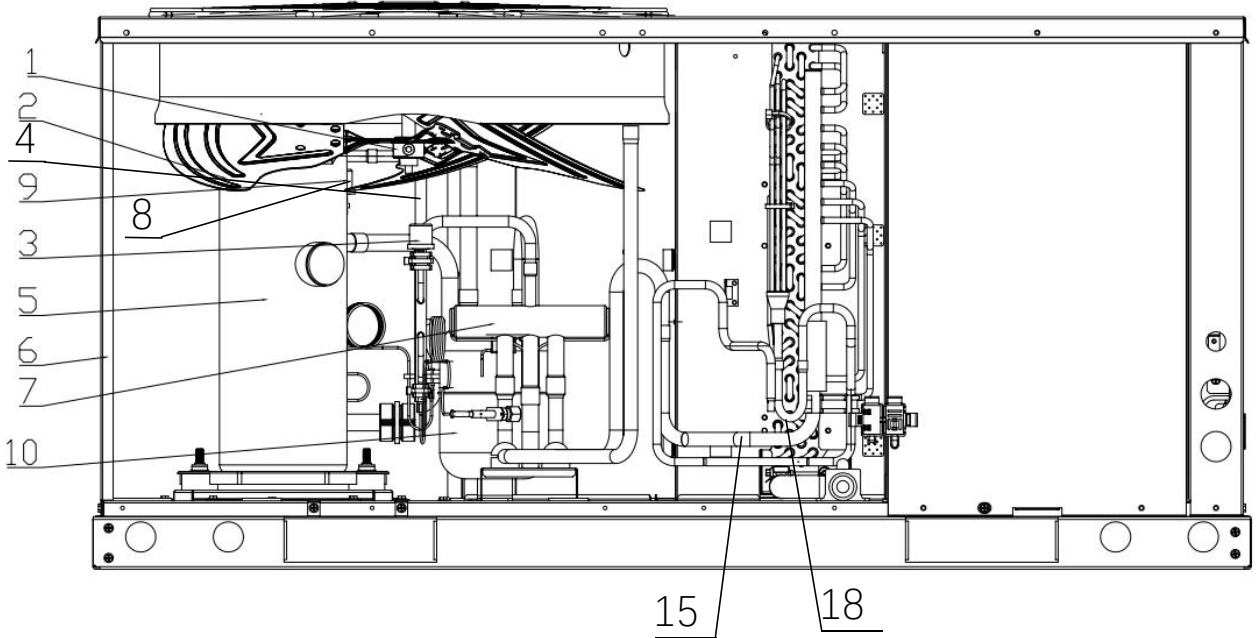

2.2 Functional Part

13.4HP 120/140/160

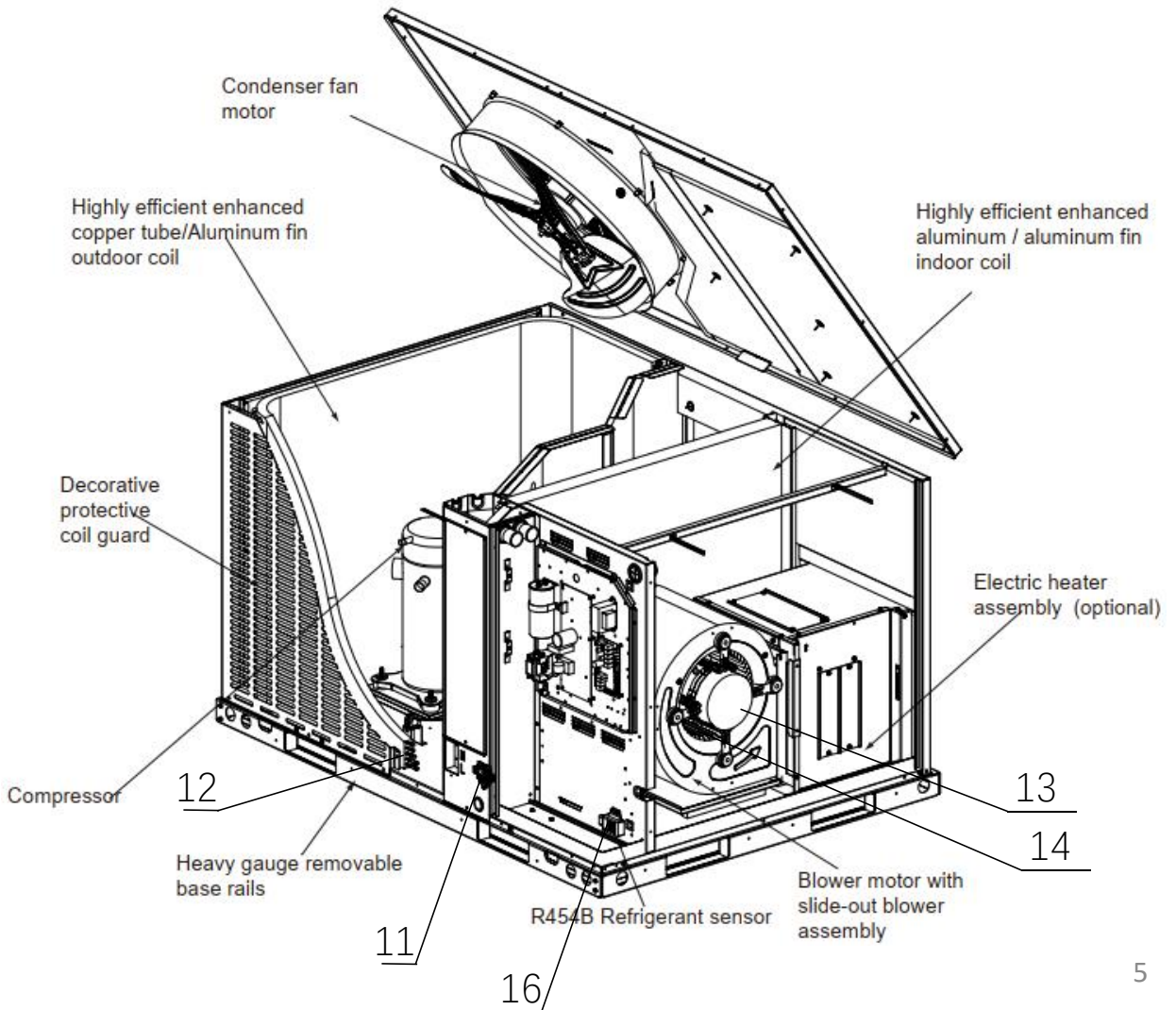
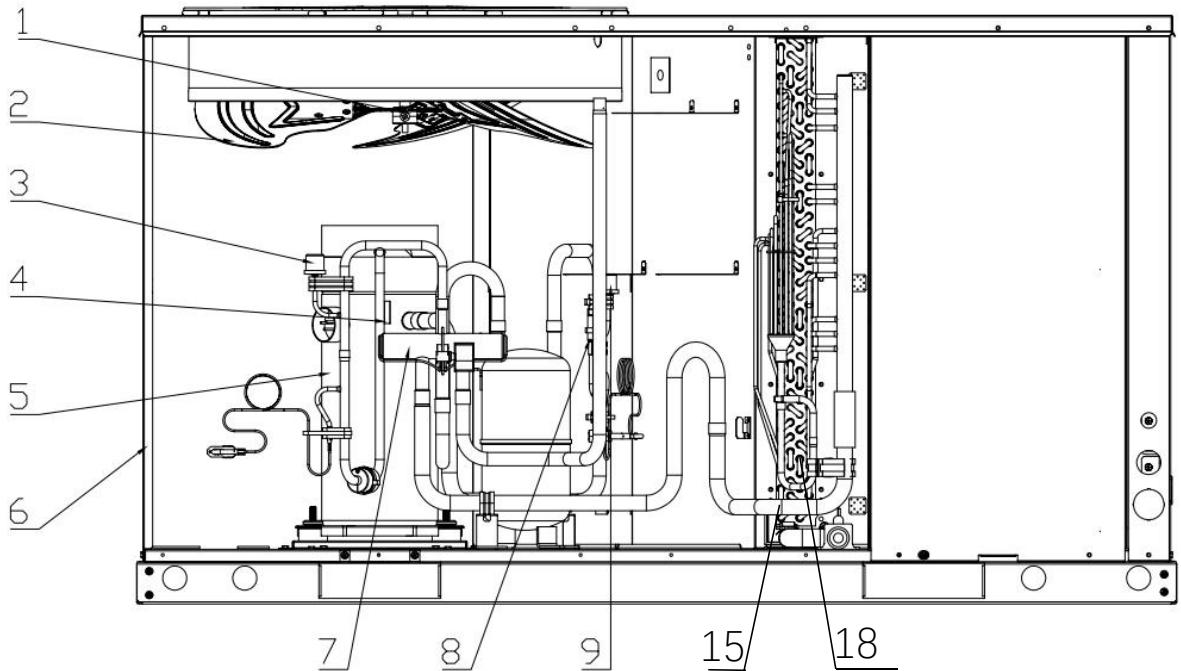

2. System Instruction

2.2 Functional Part

No.	Symbol	Part Name	Major function
1	OD Motor	Outdoor fan motor	Used to drive the fan.
2	OD Fan	Outdoor fan	Used to help heat exchange.
3	HPS	High pressure switch	Used to high pressure protection when up to 580psig and recovery when below to 435psig.
4	DTS	Compressor discharge temperature Switch	Used to compressor discharge temperature protection.
5	Comp.	Compressor	Provides power for refrigerant circulation.
6	/	Outdoor Coil	Heat exchange with outdoor air.
7	RV	Reversing Valve	Used to switch mode between cooling and heating.
8	FPA	Fusible piug assembly	Used to high suction temperature protection when up to 172.4F .
9	LPS	Low pressure switch	Used to low pressure protection when below to 14.5psig and recovery when up to 31.9psig.
10	/	Accumulator	Prevent liquid refrigerant from entering the compressor.
11	T4	Ambient temperature sensor	Used to ambient protection and defrost control.
12	T3	Outdoor coil temperature sensor	Used to discharge temperature protection and Fan control in cooling mode, and defrost control.
ID Motor	ID Motor	Indoor fan motor	Used to help heat exchange.
14	ID Fan	Indoor fan	Used to help heat exchange.
15	/	Throttle (orifice)	Used for refrigerant throttling and pressure reduction
16	/	R454B Refrigerant Sensor	Used to detect refrigerant leakage
17	/	Wind pressure switch	Used to detect the pressure difference between the wind wheel and the electronic control chamber, to determine whether the indoor airflow meets the requirements of electrical heater.
18	/	Indoor unit Coil	Heat exchange with indoor air.

2.3 Refrigerant Flow Chart

Cooling Operation/Defrost Operation

- High pressure gas
- High pressure liquid
- Low pressure

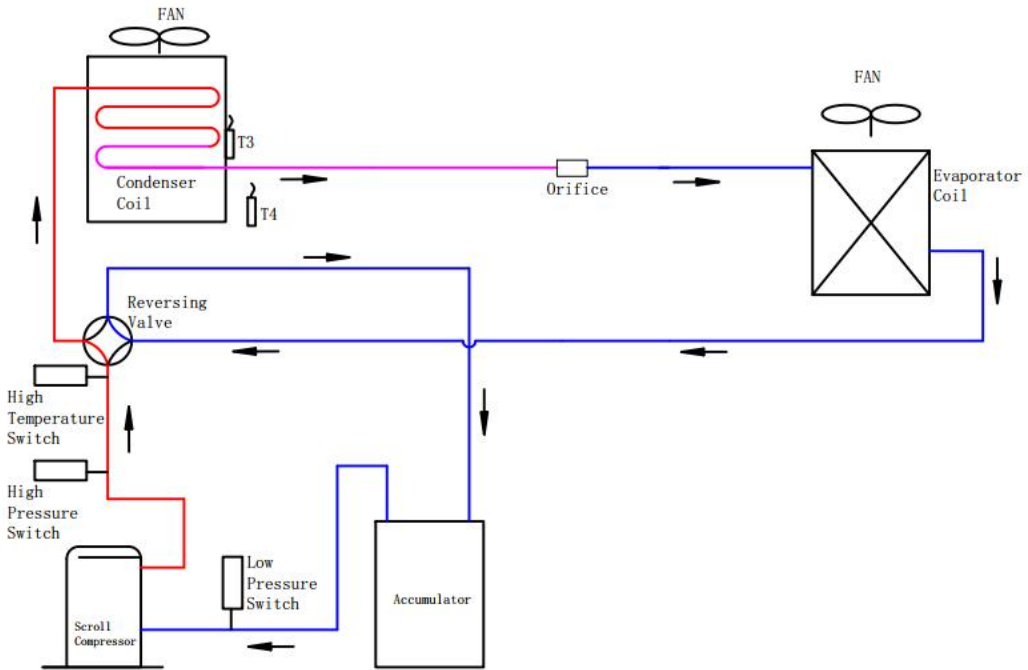

Heating Operation

- High pressure gas
- High pressure liquid
- Low pressure

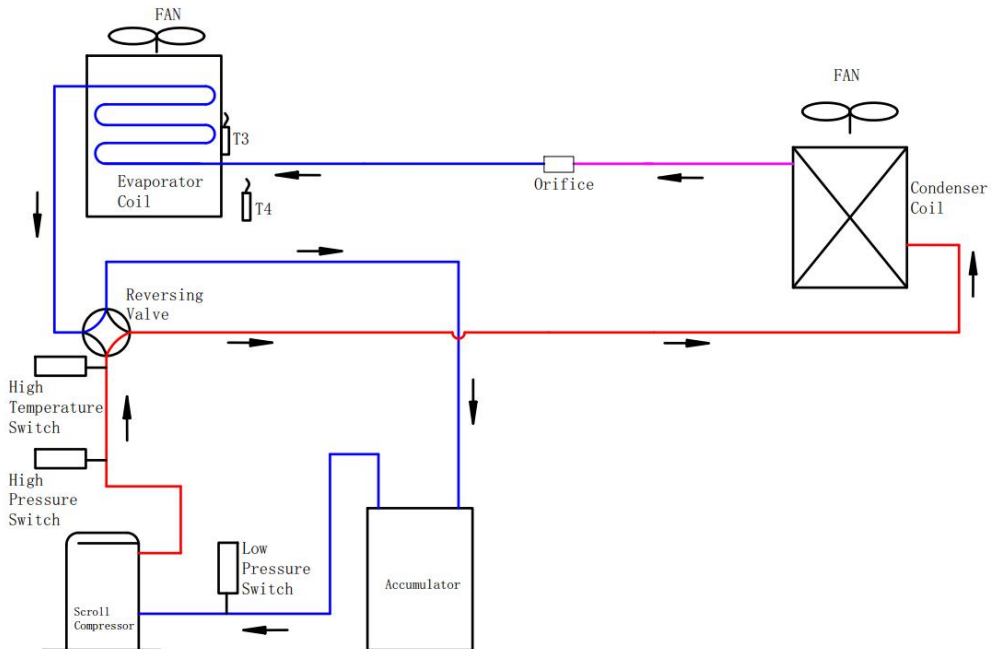

PART 3 Function and Control 8

3.1 Function General 9

3.1.1 Unit Shutdown Control 10

3.1.2 Unit Standby Control 10

3.1.3 Unit Normal Operation 11

3.1.4 Unit Special Control 16

3.1.5 Unit status Code 16

3.1.6 Check and Force Function 17

3.1.7 Fault of Main Board 18

3.1.8 Unit Protection Control or Restart 19

3.1.9 Unit Fault Control or Restart 21

3.1 Function General

Note:

Module board used to control the whole unit function for 24/30/36K, only control the outside function for 42/48/60K.

Control board used to control the inside function for 42/48/60K.

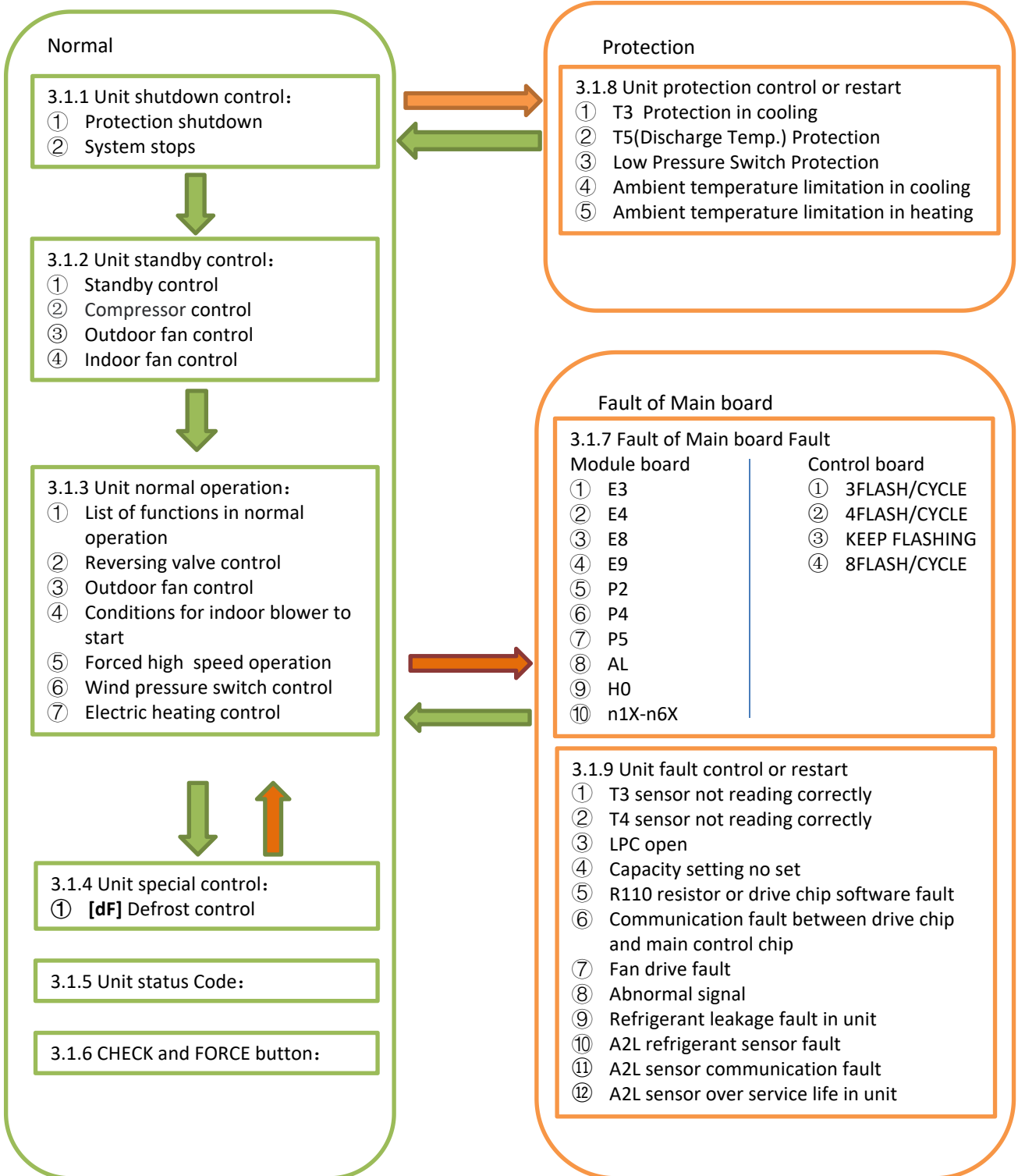

3.1.1 Unit shutdown control

(1) Unit protection shutdown

To protect the unit, our system will shut down when there is something abnormal. Also the LED 1(Red) DSP of module board and LED 2(GREEN) of control board would show the fault code when fault present.

(2) Thermostat satisfied shutdown

Anytime system is in unit standby, LED 1 (Red) of module board will flash slowly (2s ON /2s off), DSP would show"——"

3.1.2 Unit standby control

(1) Standby control

When compressor stopped, the outdoor fan would stop immediately.

Before compressor start, the outdoor fan motor will run at least 15 seconds.

(2) Compressor control will steady

When there is no "Y" signal, the compressor will stop , If the standby time is more than 3 minutes, the compressor will start after receiving "Y" signal.

(3) Outdoor fan control

When there is no "Y" signal, the outdoor fan will stop, When there is "Y" signal, the outdoor fan will start.

(4) Indoor fan control

When there is no operation signal, the indoor fan will stop after a delay of 90 seconds, and when there is a operation signal, the indoor fan would start immediately.

3.1.3 Unit normal operation

(1) List of functions in normal

[Cooling]

Symbol	Part Name	Control status
Comp.	Compressor	ON
RV	The Reversing Valve	OFF
OD Fan	Outdoor fan motor	10 speeds ECM Motor controlled by T3.
ID Fan	Indoor fan motor	ON

[Heating]

Symbol	Part Name	Control status
Comp.	Compressor	ON
RV	The Reversing Valve	ON
OD Fan	Outdoor fan motor	10 speeds ECM Motor controlled by T3.
ID Fan	Indoor fan motor	ON

[Defrost]

Symbol	Part Name	Control status
Comp.	Compressor	ON
RV	The Reversing Valve	OFF
OD Fan	Outdoor fan motor	OFF
ID Fan	Indoor fan motor	ON

(2) Reversing valve control control

The heat pump need "B" signal of 24V wires.

●Cooling:

The reversing valve is off during cooling.

●Heating:

The reversing valve is on during heating and heating standby.

3.1.3 Unit normal operation

(3) Outdoor Fan control

[Cooling]

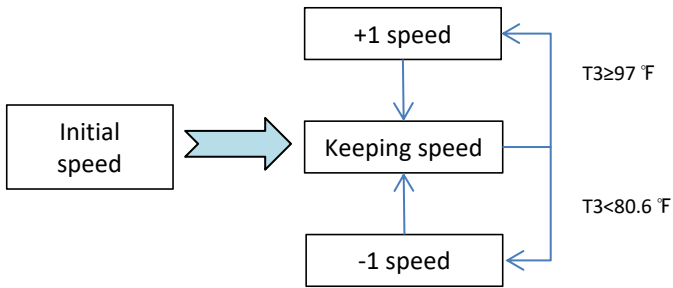

Note: ± 1 speed/25 seconds, 10 speeds ECM motor.

[Heating]

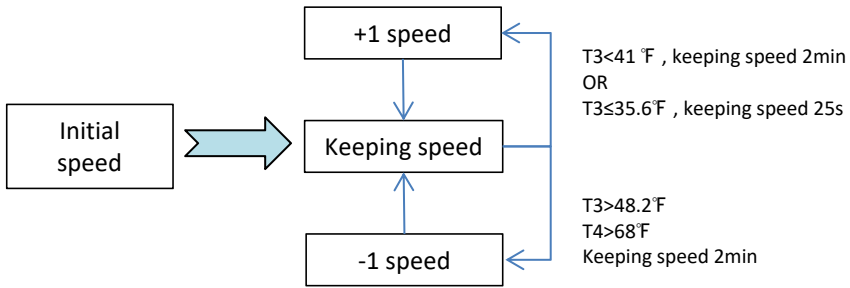

Note: 10 speeds ECM motor.

3.1.3 Unit normal operation

(4) Conditions for indoor blower to start

When the following conditions are met, the blower will start.

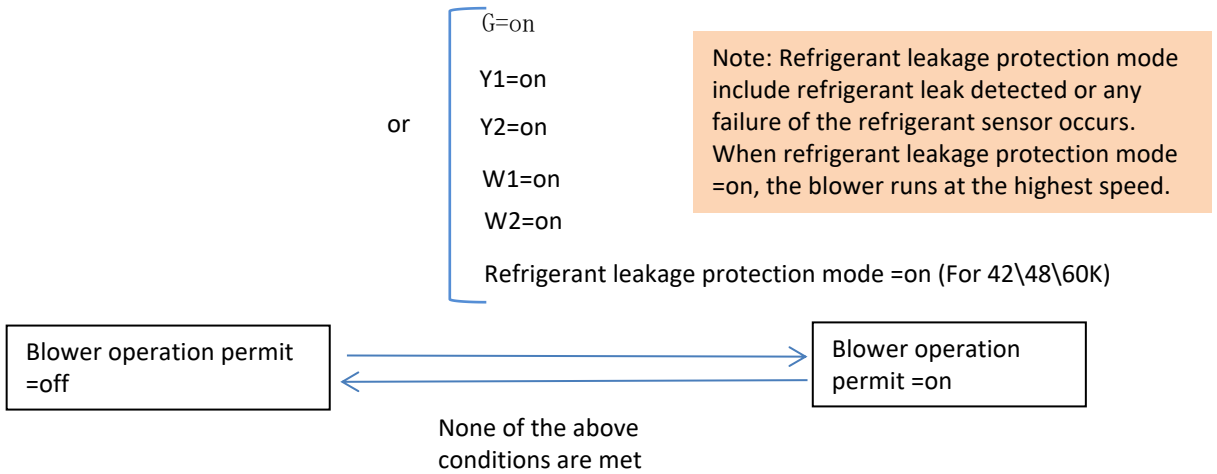

(5) Forced high speed operation

For 30\36\42\48\60K when there is electric heating start signal, the blower is forced to run at high speed.

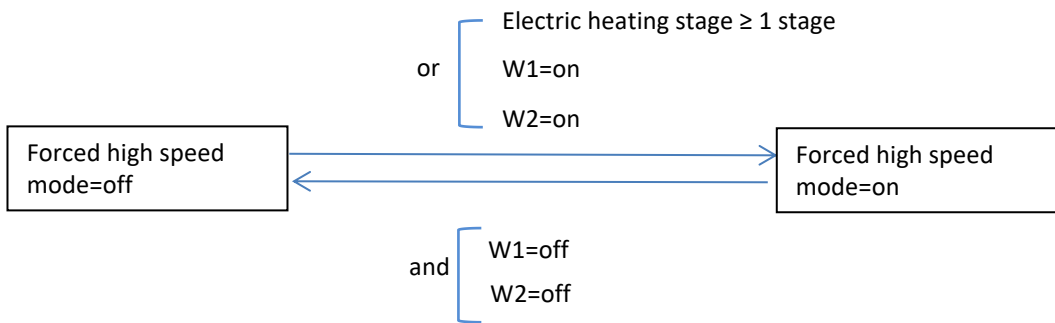

3.1.3 Unit normal operation

(6) Wind pressure switch control (For 24\30\36K)

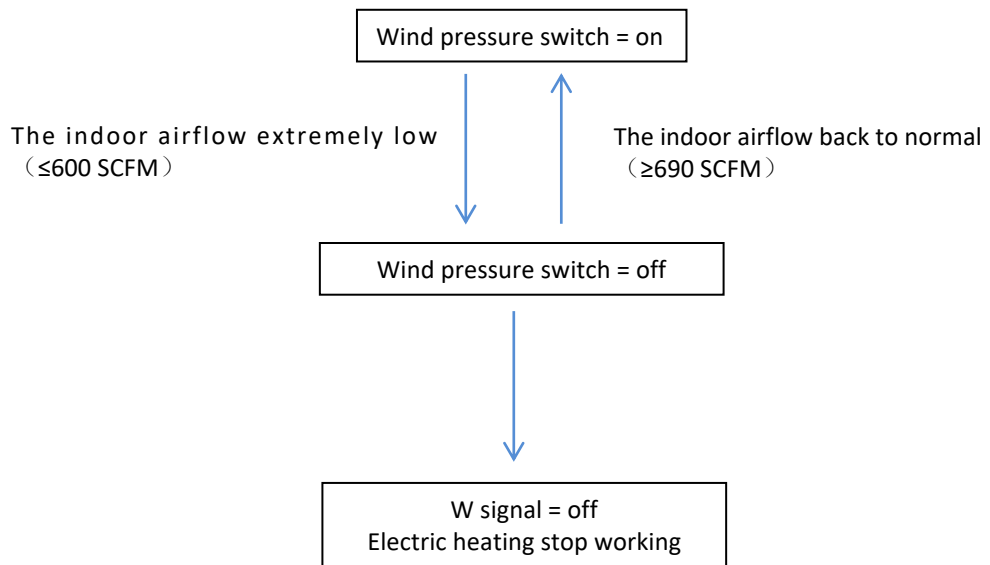

Note: The wind pressure switch can only use the factory model.

3.1.3 Unit normal operation

(7) Electric heating control

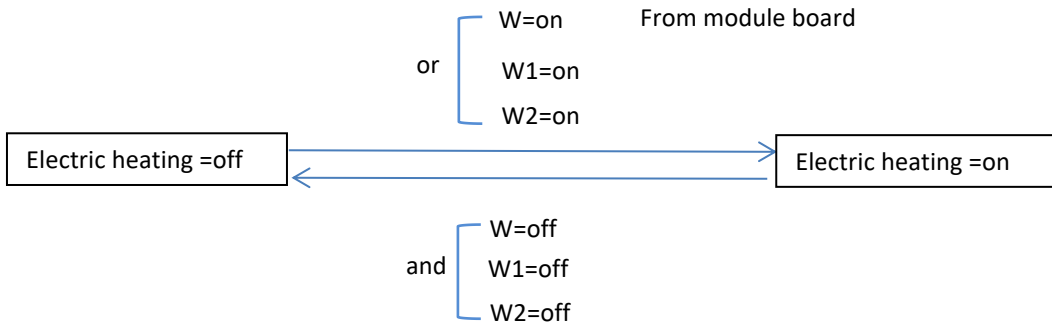

Notes: W signal is from From module board equal to W1 signal, W1/W2 is from Thermostat

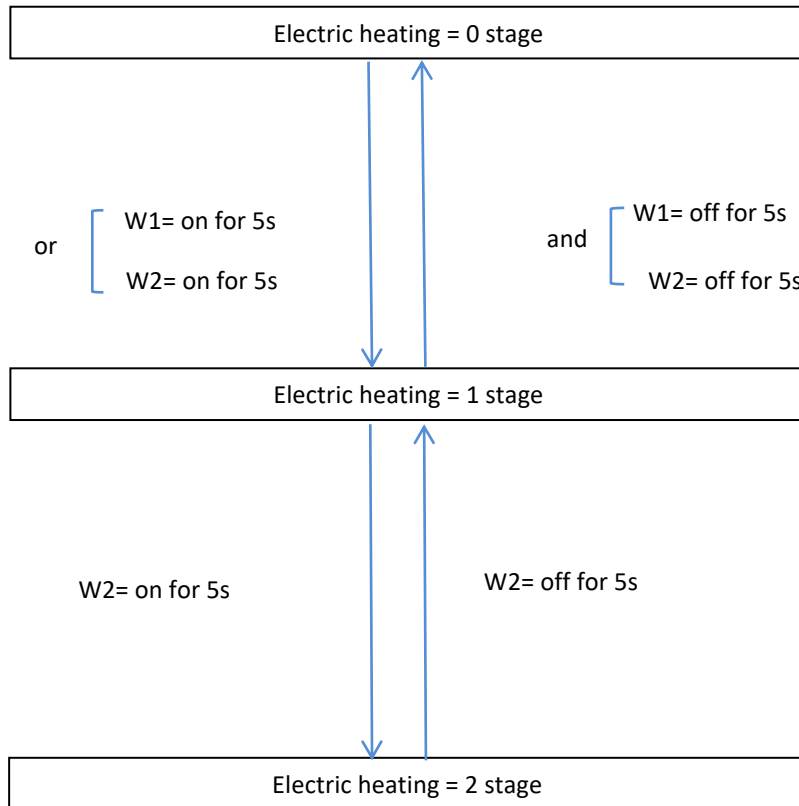

3. Function and Control

3.1.4 Unit special control

(1) [dF] Defrost control

● The Demand Defrost Control (DDC) monitors the ODU coil temperature using thermistor (T3). A second thermistor (T4) monitors outdoor ambient temperature. Based on these parameters, as well as accumulative running time and Standby time, the DDC calculates proper initiation of defrost.

● Any one of three conditions is required to enter defrost:

1. After T3 is achieved.
 - T3<32 °F and lasted for 60 minutes(50 minutes for 42/48K/60K)
 - Run heating mode first time or "Standby time" is 2 hours, T3<28°F when starting and lasted for 15 minutes
2. After T4 is achieved.
 - T4<37.4°F and lasted for 65 minutes(55 minutes for 42/48K/60K)
3. When defrost ended because of compressor stop running,start heating mode again and T3 T3<32 °F and lasted for 20 minutes.
4. T4≥21.2°F ,T3 <30.2°F ,and T3 <17.6+33.44XT4°F lasted for 3 minutes ,and compressor keep running≥40minutes.

3.1.5 Unit status Code

DSP: Two-digits digital tube shows the operating status. Shows operation mode when operating normally, shows error code when error occurs

Code	Description
--	Standby
-C	Cooling mode
-H	Heating mode
FC	Forced cooling mode
dF	Defrosting mode
CH	Abnormal signal

Note: For "CH" code, it means the signal wire from control board to module board isn't connected correctly. The following condition may cause this code.

Signal	B	Y	W
Status	0	1	1
(1 for ON;	1	0	1
0 for OFF)	0	0	1

3. Function and Control

3.1.6 Check and Force Function

● Force button

Long press "Force" at least 6 seconds and enter Defrost mode

Short press "Force " and enter Force Cooling mode

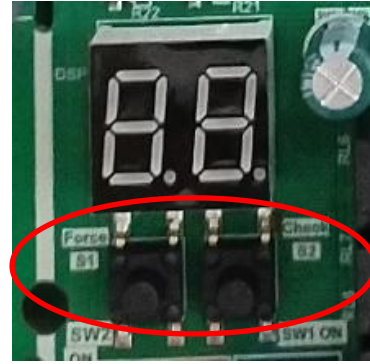

● Check button

To display system parameters, press the "Check" button to index through the series of parameters available.

The first time you press the "Check" button, it will display the sequence, and after 1 second it will display the value of the

parameter. If you press the "Check" button again, it will display the next sequence.

After 30 seconds on same parameter, the display will revert back to normal status.

NO.	Point check content
1	Unit capacity
2	Operation mode
3	Current fan speed(Actual speed divided by 10, 560R is represented by '56.', 1050R is represented by 'A5.')
4	Target fan speed(Actual speed divided by 10, for example, 560R is represented by'56.', 1050R is represented by 'A5.')
5	T3 temperature(°F)(if the value is less than 100, the actual value is displayed. if over 100, divided by 10, 135 is represented by '13.', if it is negative, '1.0' means -10, '.5' means -5)
6	T4 temperature(°F)(if the value is less than 100, the actual value is displayed. if over 100, divided by 10, 135 is represented by '13.', if it is negative, '1.0' means -10, '.5' means -5)
7	Compressor running time(day) (if the value is less than 100, the actual number of days is displayed. if over 100 and less than 1000, 360 days are represented by '36.', if over 1000, 3600 days are represented by '3.6.')
8	Main control chip software version
9	Drive chip software version
10	Y1 signal state(1=ON, 0=OFF)
11	B signal state(1=ON, 0=OFF)
12	W signal state(1=ON, 0=OFF)
13	Y2 signal state(1=ON, 0=OFF)
14	RV condition (1=ON, 0=OFF)
15	High wind pattern (1=ON, 0=OFF)
16	Last fault code
17	Last second fault code
18	Last third fault code
19	--

3. Function and Control

3.1.7 Fault of Main board:

(1) Module board

No.	Protection code	Protection control description	Possible Reason
1	E3	T3 sensor fault	T3 sensor is short circuit or open circuit
2	E4	T4 sensor fault	T4 sensor is short circuit or open circuit
3	E8	Capacity setting no set	Capacity setting(SW2) isn't set/Program error/Module board is failure
4	E9	R110 resistor or drive chip software fault	Fan is failure/Module board is failure
5	P2	LPC protection	Speed message isn't wrote in module board
6	P4	Discharge temperature protection	High temperature and overload/Throttle blockage/Charging leakage (low refrigerant)/DTS fault
7	P5	T3 high-temperature protection	High temperature and overload/Poor heat exchange on condensing side/T3 fault
8	AL	Ambient temperature limitation	Ambient temperature is out of the range/There are other cooling sources around T4
9	H0	Communication fault between drive chip and main control chip	Program error/Module board is failure
10	n1X-n6X	Fan drive fault	Wiring error/Fan is failure/Module board is failure

(1) Control board

No.	LED light flash	Fault code description	Supposed cause
1	3FLASH/CYCLE	A2L REFRIGERANT SENSOR FAULT	A2L sensor fault
2	4FLASH/CYCLE	A2L REFRIGERANT SENSOR COMMUNICATION FAULT	Wiring error/ A2L sensor fault
3	KEEP FLASHING	REFRIGERANT LEAK PROTECTION	Refrigerant leak
4	8FLASH/CYCLE	A2L SENSOR OVER SERVICE LIFE	Refrigerant sensors are used for more than 15 years

3. Function and Control

3.1.8 Unit protection control or restart:

(1) T3 Protection in cooling

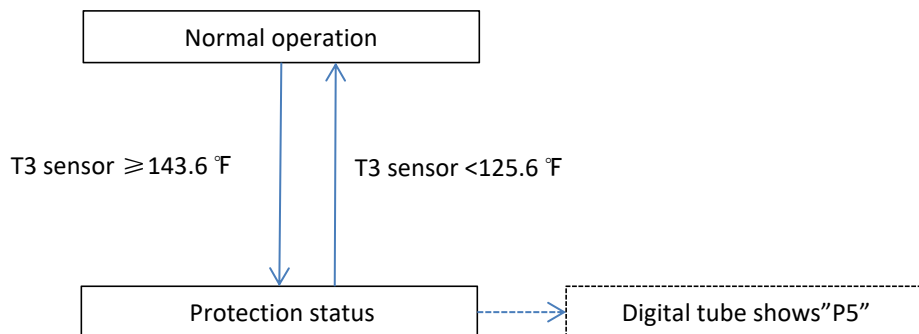

(2) T5(Discharge Temp.) Protection

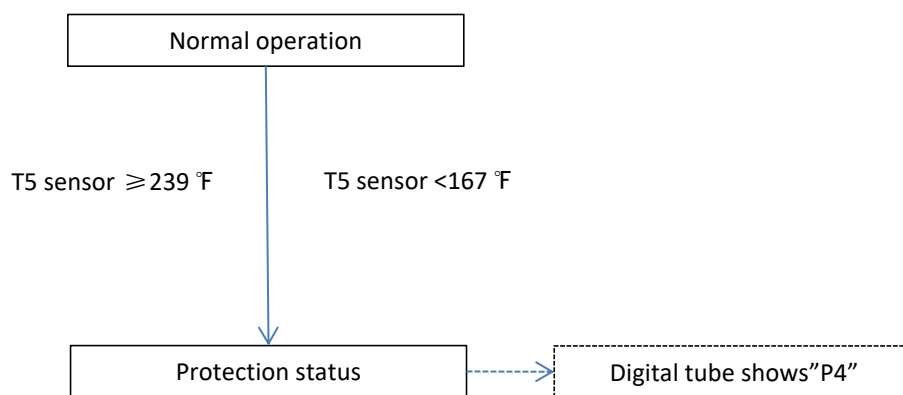

(3) Low Pressure Switch Protection

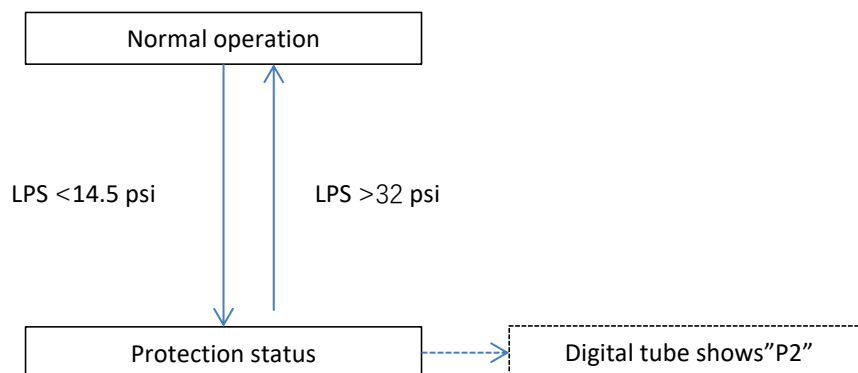

3. Function and Control

3.1.8 Unit protection control or restart:

(4) Ambient temperature limitation in cooling

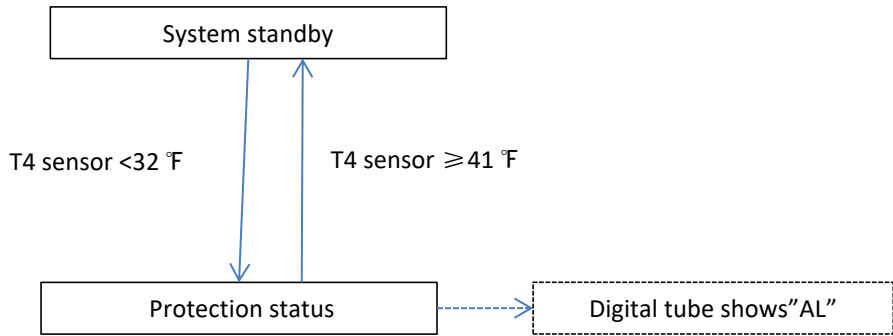

(5) Ambient temperature limitation in heating

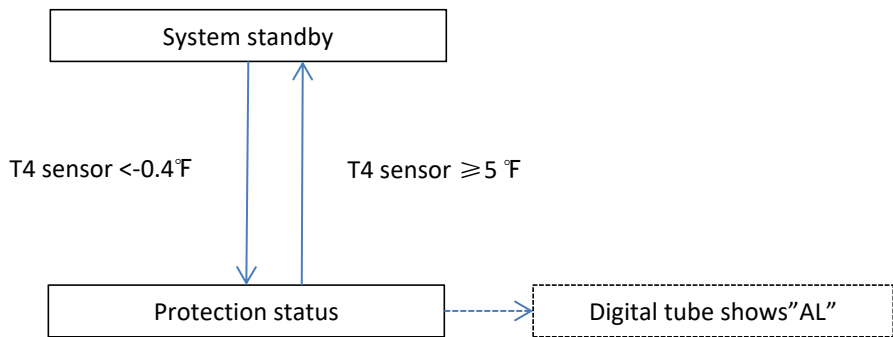

(6) High Pressure Switch Protection

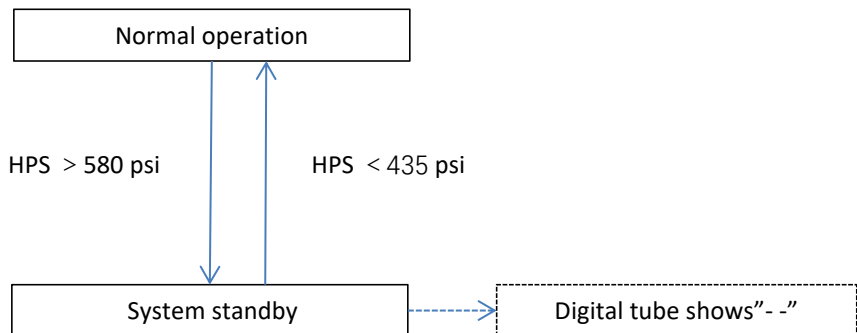

3. Function and Control

3.1.9 Unit fault control or restart:

(1) T3 sensor not reading correctly

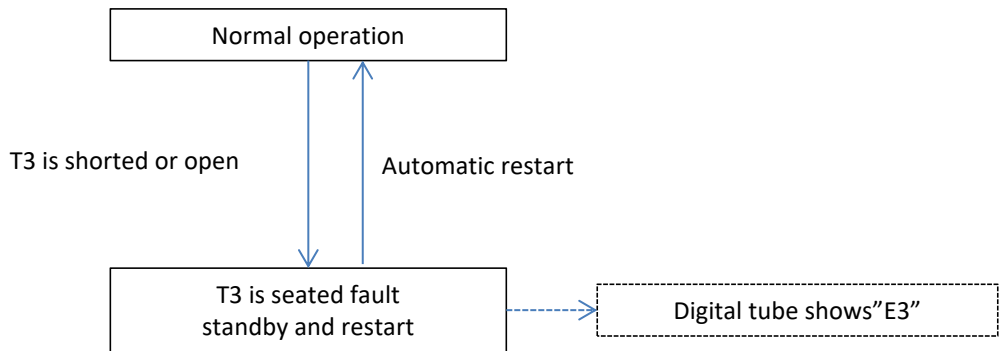

(2) T4 sensor not reading correctly

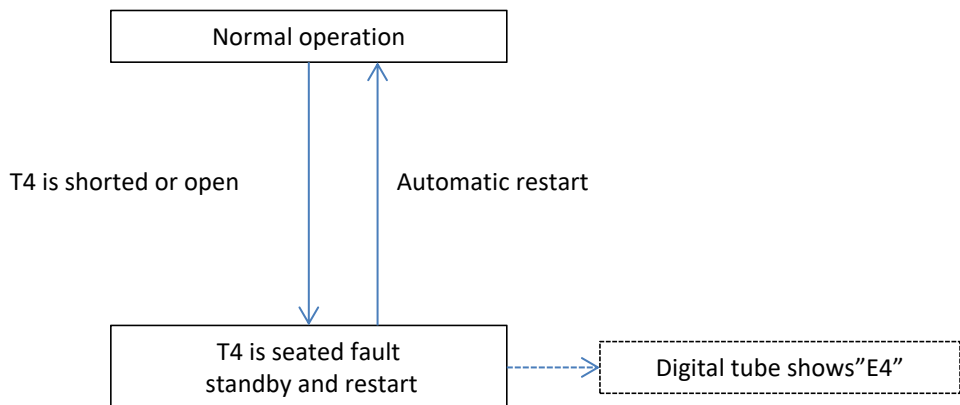

(3) LPC open

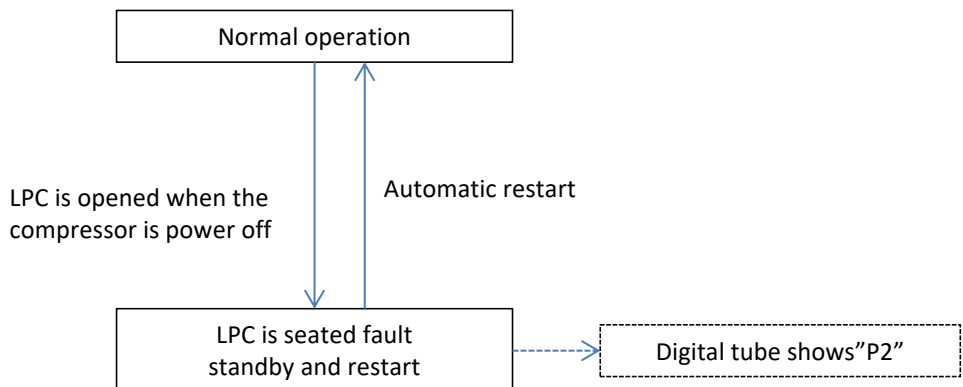

3.1.9 Unit Fault control or restart :

(4) Capacity setting no set

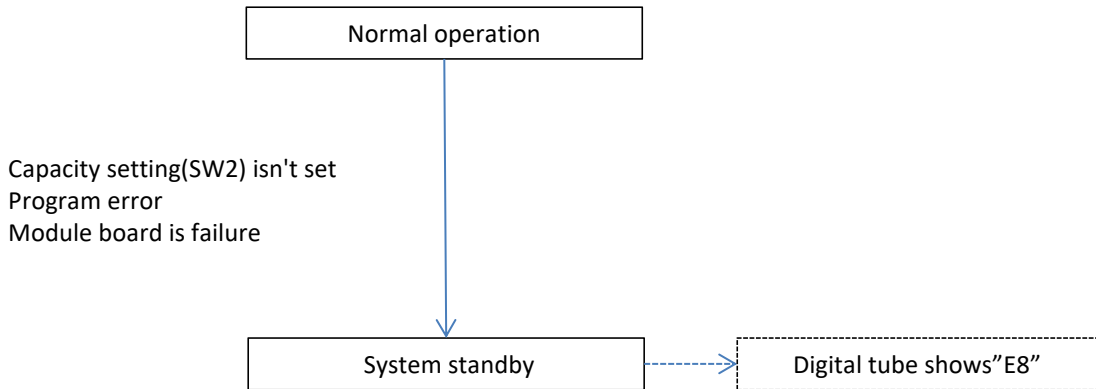

(5) Module board or drive chip software fault

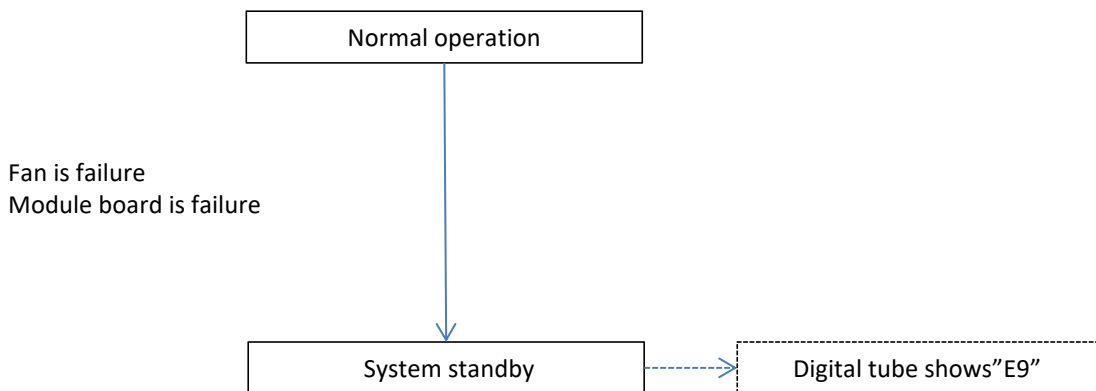

(6) Communication fault between drive chip and main control chip

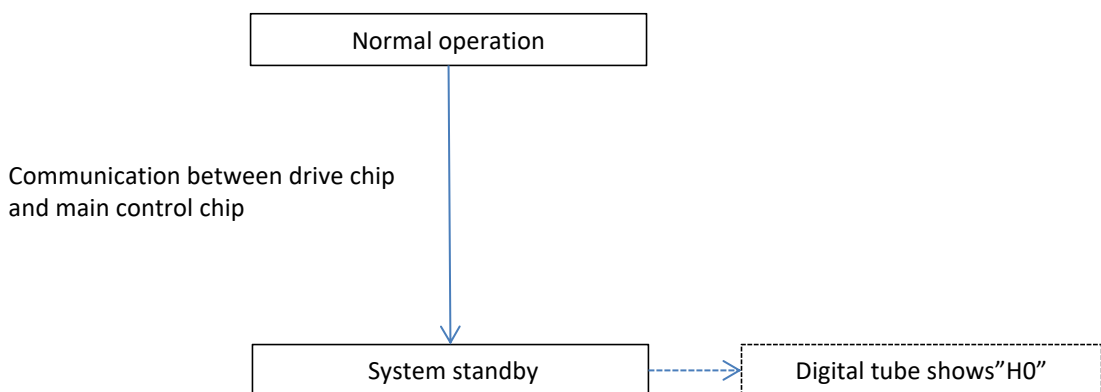

3.1.9 Unit Fault control or restart :

(7) Fan drive fault

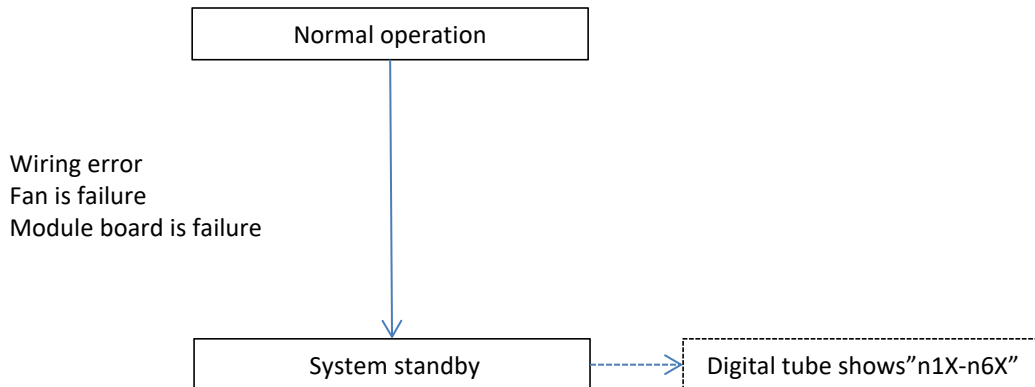

(8) Abnormal signal

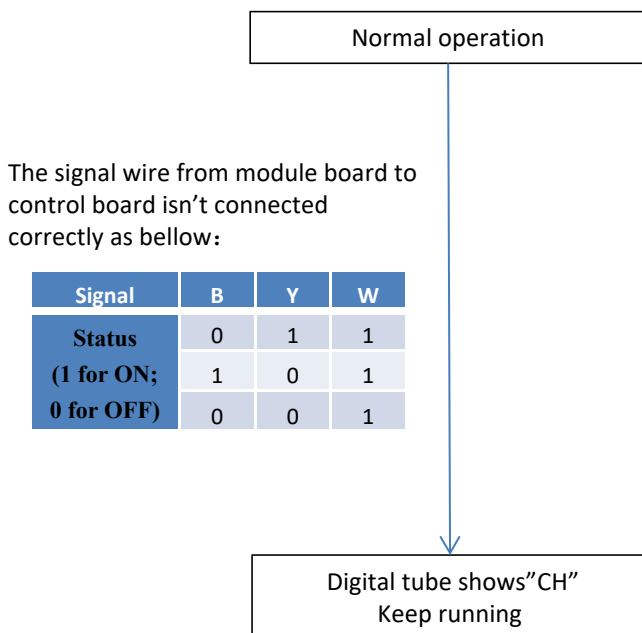

3. Function and Control

3.1.9 Unit Fault control or restart :

(9) Refrigerant leakage fault in control board

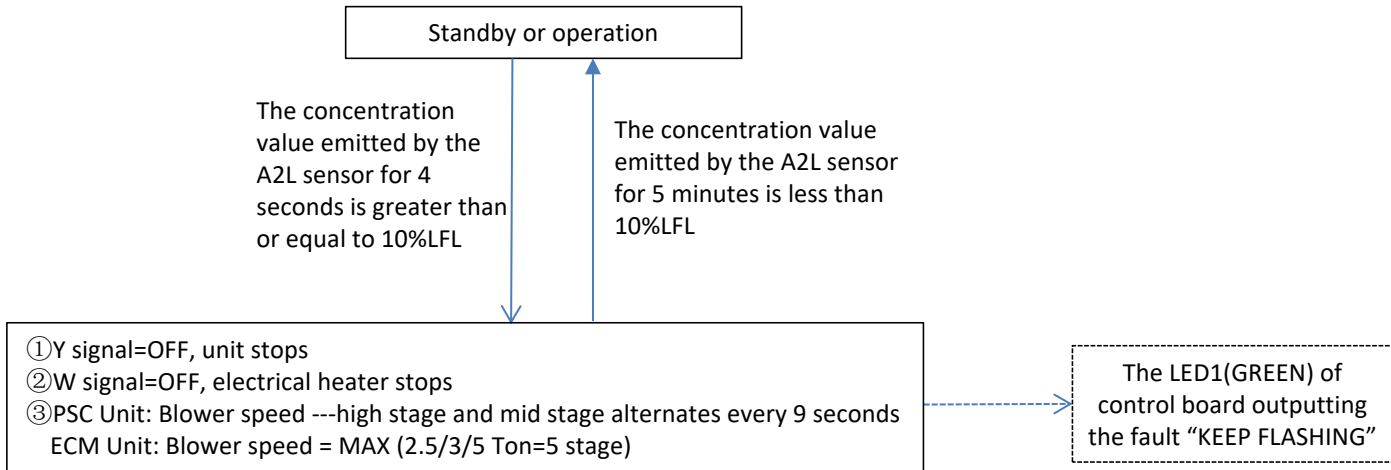

(10) A2L refrigerant sensor fault (A2L sensor)

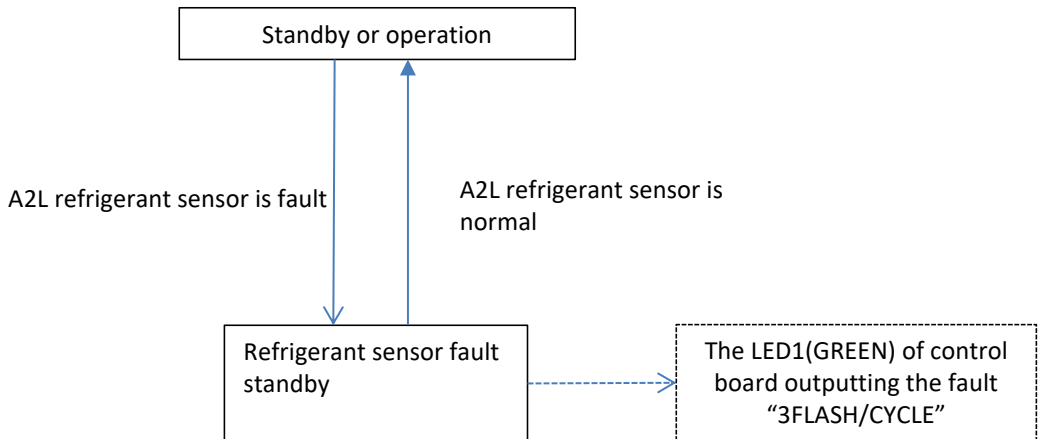

(11) A2L sensor communication fault (A2L sensor)

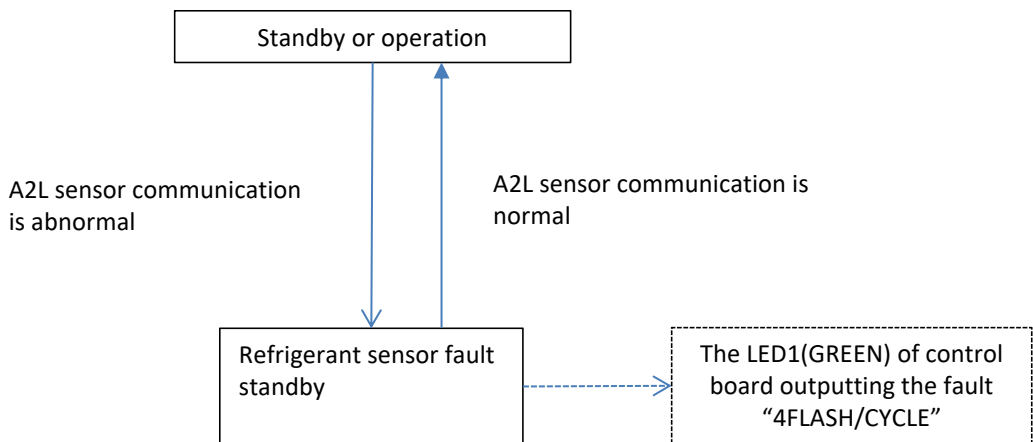

3. Function and Control

3.1.9 Unit Fault control or restart :

(12) A2L sensor over service life in control board

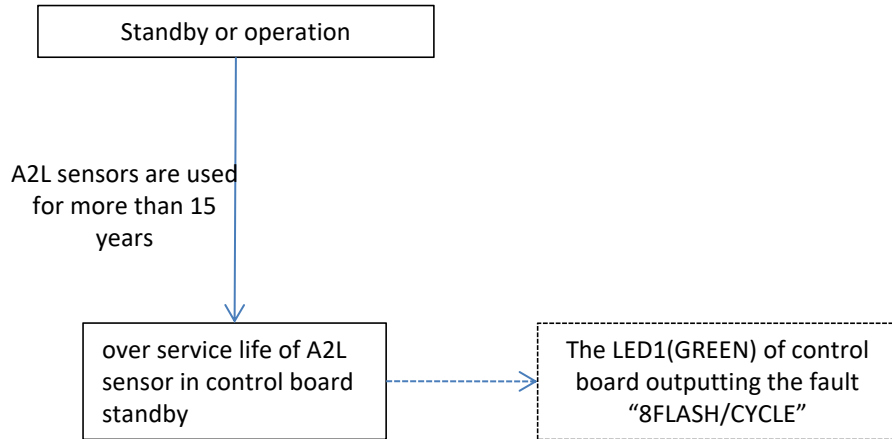

WARNING

If a leak is detected, follow safety procedures: Immediately evacuate all persons from the room or space, and contact the qualified licensed service personnel to advise them that the refrigerant R454B (A2L class flammable refrigerant) leak has occurred.

WARNING

The installation of the refrigerant leakage sensor shall allow access for checking, repair or replacement by an authorized person.

PART 4 Field settings	26
4.1 Pre Operation	27
4.1.1 Checks before Test Operation	27
4.1.2 Control wiring	28
4.1.3 Setting by DIP switches	29
4.1.4 Turn power on	32
4.2 Trial Operation	33
4.2.1 Trial Operation	33
4.2.2 Refrigerant Quantity Check	34
4.2.3 External Static Pressure Setup	35

4. Field settings

4.1 Pre-operation

4.1.1 Checks before test operation

No.	Checkpoints	Cautions or warnings
1	Are all units securely installed?	Dangerous for turning over during storm Possible damage to pipe connections
2	Is the earth wire installed according to the applicable local standard?	Dangerous if electric leakage occurs
3	Are the condenser unit installed according to location restrictions requirement?	Poor capacity abnormal operation
4	Are all air inlets and outlets of unit unobstructed?	Poor cooling Poor heating
5	Does the drain flow out smoothly?	Pipeline water leak
6	Have the connections been checked for air tight test and vacuum drying?	Poor capacity abnormal operation
7	Is a proper quantity of refrigerant charged?	Poor capacity abnormal operation
8	Do the supply power wirings connected Normally? Including the earth wiring.	Dangerous if electric leakage occurs
9	Does the earth leakage circuit breaker connected normally?	Dangerous if electric leakage occurs
10	Do the wirings of 24V signal connected according to wiring diagram? Including the thermostat wiring and setting.	abnormal operation
11	Is the supply voltage conform to the specifications on the name plate?	abnormal operation Damage unit
12	Are the cable sizes as specified and according to local regulations?	Damage of cables

4. Field settings

4.1 Pre-operation

4.1.2 Control wiring

Note: B signal need thermostat programming settings.

For heat pump systems, for 24K,30K,36K

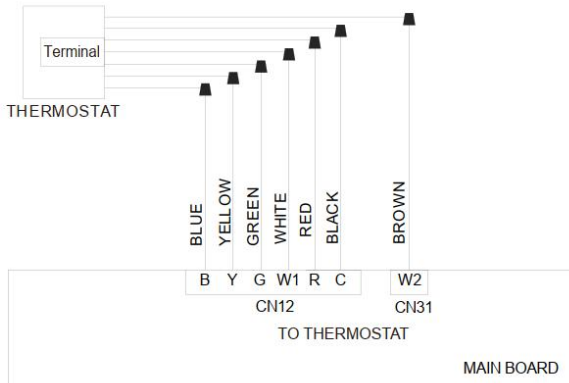

For heat pump systems, for 42K,48K,60K

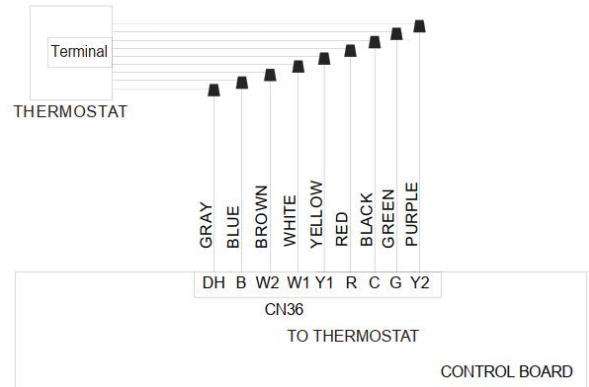

Notes:

- Be sure power supply agrees with equipment nameplate.
- Power wiring and grounding of equipment must comply with local codes.
- Low voltage wiring to be No. 18 AWG minimum conductor.
- “- - - - -” Field installed electric auxiliary heat connection
- Single-stage auxiliary heating (Supported by 2H thermostat)

- Twin-stage auxiliary heating (Supported by 3H thermostat)
- W: Electric auxiliary heat signal.
- W1: The first stage Field installed electric auxiliary heat signal.
- W2: The second stage Field installed electric auxiliary heat signal.
- The outdoor unit W signal is connected to the Electric auxiliary heat or the first stage Electric auxiliary heat.

4. Field settings

4.1 Pre-operation

4.1.3 Setting by DIP switches FOR 24/30/36K



WARNING: HAZARDOUS VOLTAGE. DISCONNECT ALL ELECTRIC POWER INCLUDING REMOTE DISCONNECTS BEFORE SERVICING. INSURE THAT ALL CAPACITORS HAVE DISCHARGED STORED VOLTAGE.

NOTICE:

1. B terminal is connected and energized for heating operation.
2. W terminal is energized in defrosting operation.

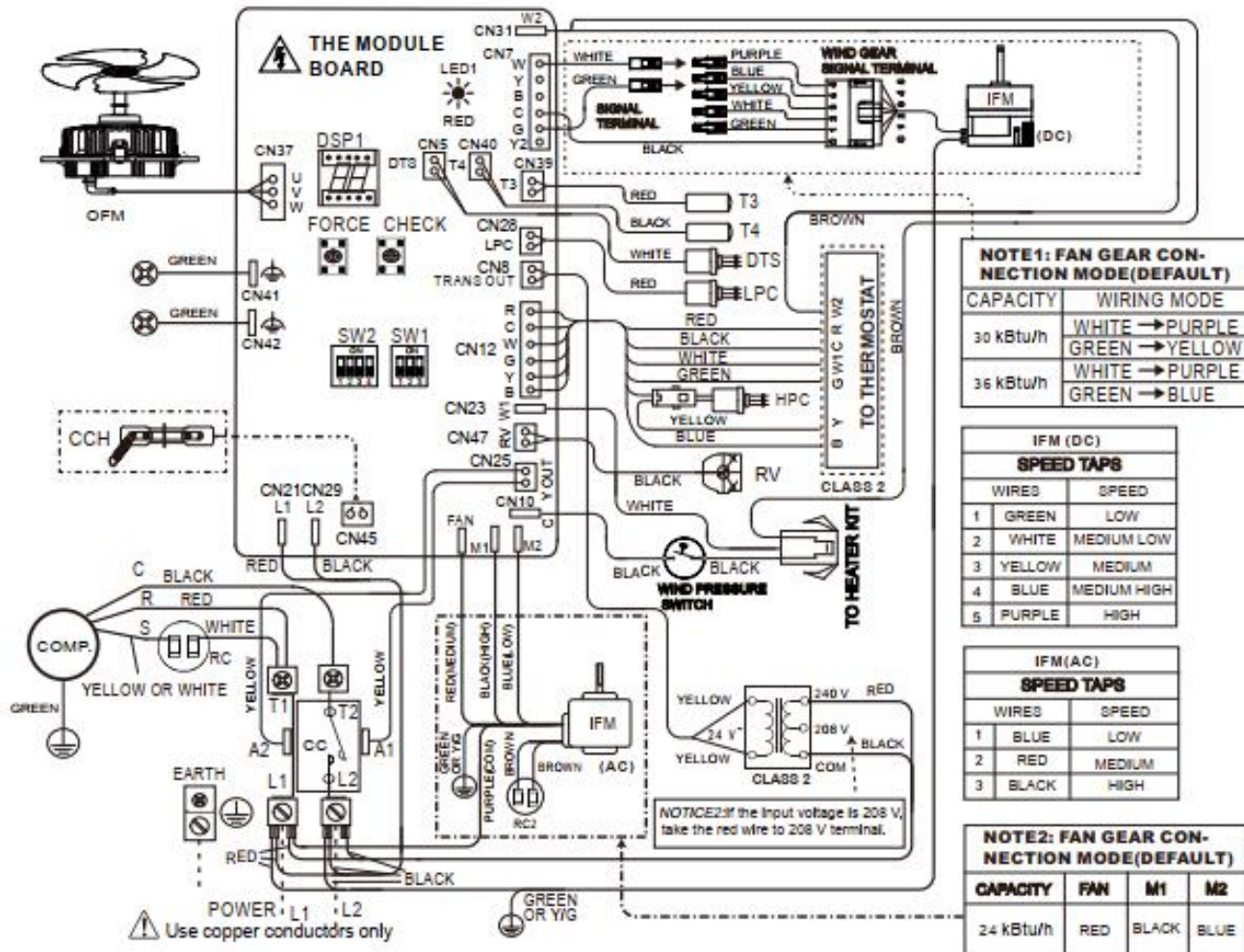

SW1	SW1-1	SW1-2	SW1-3
ON	ON	ON	ON
OFF	OFF	OFF	OFF

13.4HP package(only used for replacing board)
Reserved
Reserved
Reserved
Defrosting cycle:30 min
Defrosting cycle:60 min

CAPACITY SETTING	MODEL	24 kbtu/h 2 TON	30 kbtu/h 2.5 TON	36 kbtu/h 3 TON	SW2-4 definition
001,1	13.4 HP	001,1	010,1	010,1	100 W Fan motor
42 kbtu/h 3.5 TON		48 kbtu/h 4 TON	60 kbtu/h 5 TON		200 W Fan motor
100,1		100,1	100,1		

MODEL	DESCRIPTION
13.4 HP	13.4 SEER heat exchanger package unit.

Hazardous voltage line
- Factory standard _____
- Field installed
- Factory optional - - - - -

Extra-low-voltage line
- Factory standard _____
- Factory optional - - - - -

0/1 DEFINITION OF DIP SWITCH	CODE	DESCRIPTION
	--	Standby
	-C	Cooling mode
	-H	Heating mode
	FC	Forced cooling mode
	dF	Defrosting mode
	CH	Abnormal signal

Force	Press 1 s	Press 6 s	Press 1 s
Check	Press 1 s	Press 6 s	Press 1 s

Forced cooling mode
Forced defrosting mode
Check the system parameters

CODE	DESCRIPTION
CC	Compressor Contactor
COMP.	Compressor
CCH	Crankcase Heater
T4	Ambient Temperature Sensor
T3	Pipe Temperature Sensor
HPC	High Pressure Cut-out Control
LPC	Low Pressure Cut-out Control
DTS	Discharge Temperature Switch
OFM	Outdoor Fan Motor
IFM	Indoor Fan Motor
RC	Run Capacitor
RV	Reversing Valve



WARNING!

Cabinet must be permanently earthed, and all wiring conform to UL80335. Replacement wires must be the same gauge and insulation type as original wires.

4. Field settings

4.1 Pre-operation

4.1.3 Setting by DIP switches FOR 42/48K

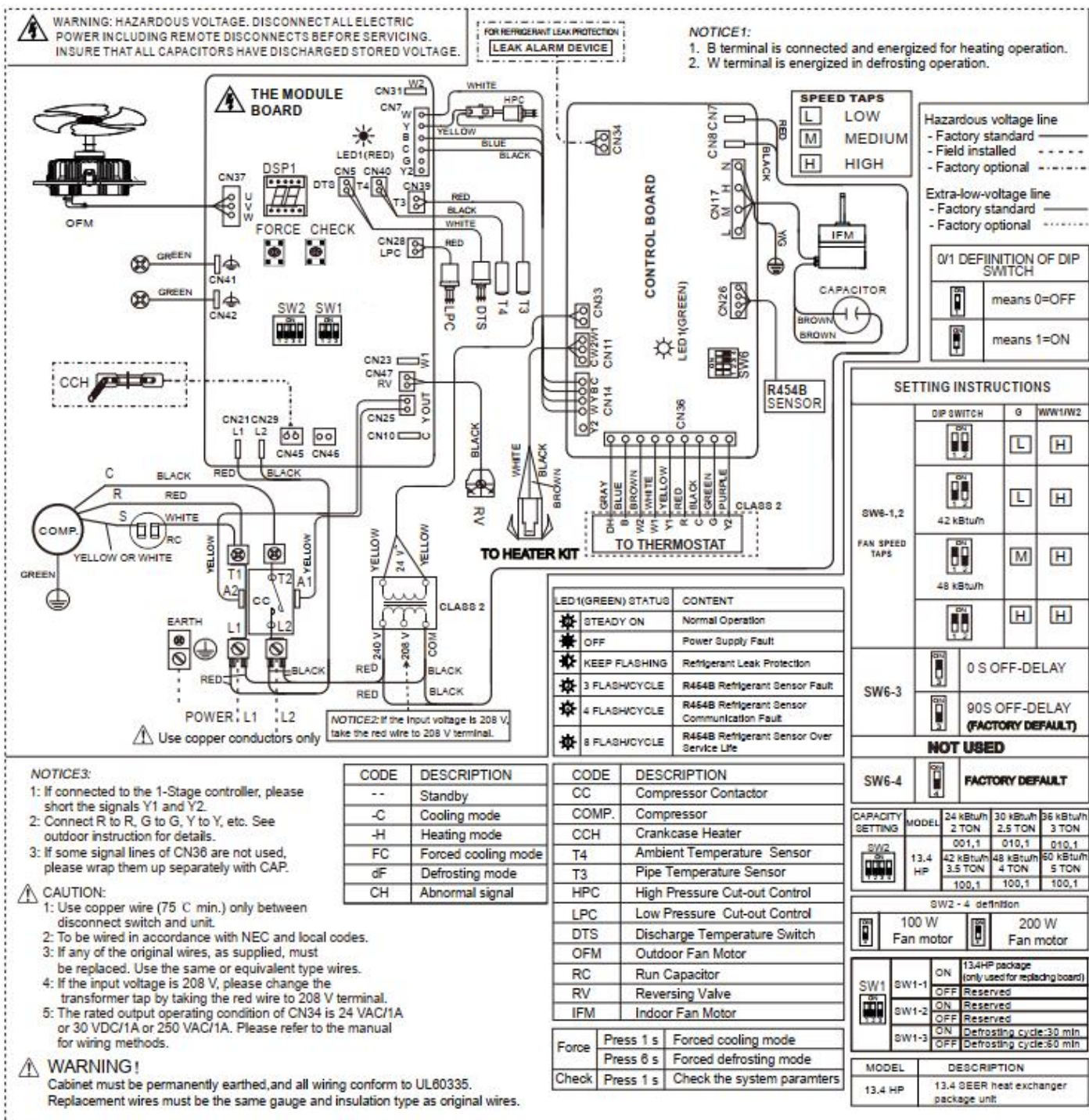

4. Field settings

4.1 Pre-operation

4.1.3 Setting by DIP switches FOR 60K

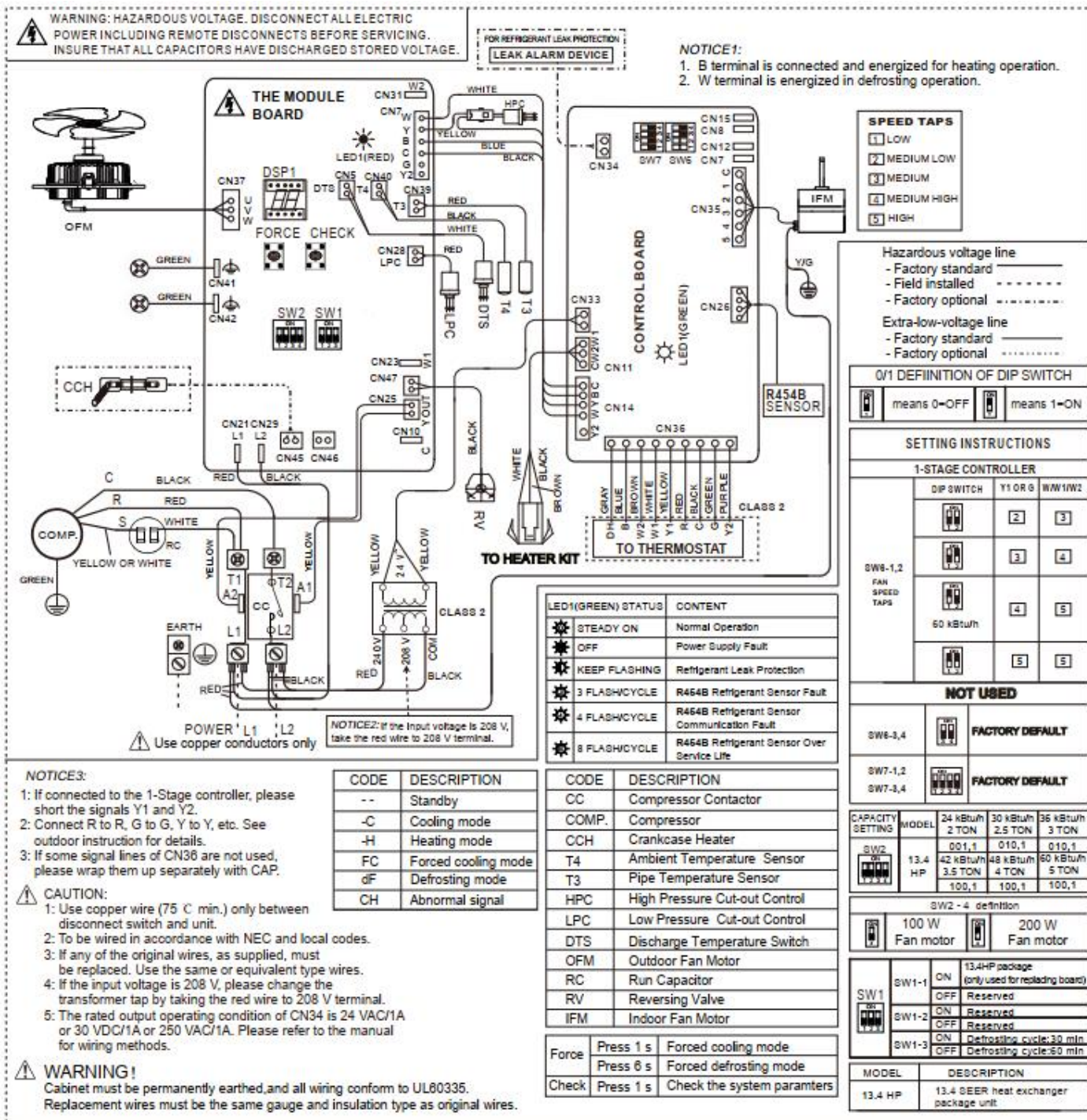

4.1 Pre-operation

4.1.4 Turn power on

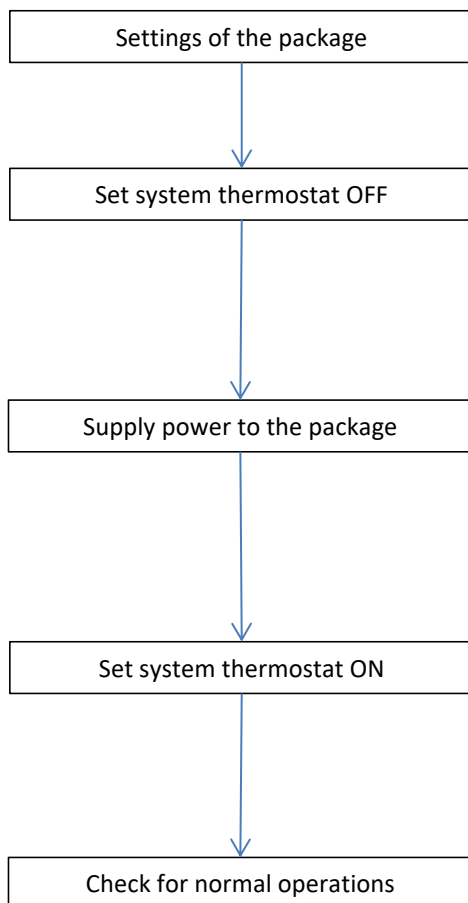

Note:
Make field setting if needed.
(For the setting procedure, refer to information in “4.1.3 Setting by DIP switches”)

Note:
In a normal condition, the LED1 flash slowly (2S ON/2S OFF) and LED2 steady on.

Note:
Be sure to turn the power on 1 hour before starting operation when the ambient temperature is below **70°F**

Note:
Check operations
Check for the 24V signal from thermostat
Check for operation mode
Check for the digital display shows the compressor frequency

4.2 Trial Operation

4.2.1 Trial Operation

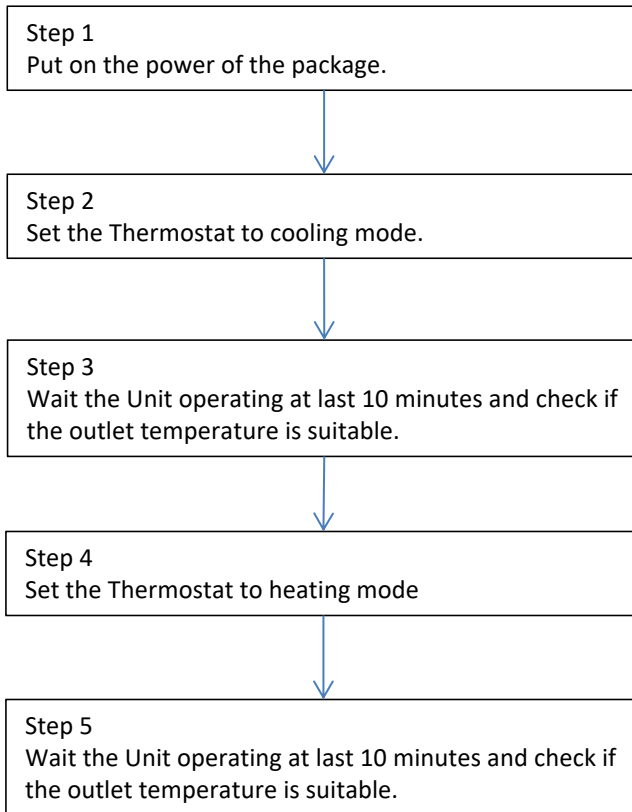

4.2.2 Refrigerant Quantity Check

The appliance has been filled with refrigerant, and the system does not need to re-add refrigerant except for maintenance.

If need to add refrigerant to appliance, refrigerant can be charged according to the prototype nameplate or the following table.

Model	24K	30K	36K	42K	48K	60K
Refrigerant Type	R454B	R454B	R454B	R454B	R454B	R454B
Refrigerant Factory Charged	1750g	1650g	1700g	2700g	2750g	2700g
	3lb-14oz	3lb-10oz	3lb-12oz	5lb-15oz	6lb-1oz	5lb-15oz

4.2.3 External Static Pressure Setup

To measure external static pressure:

1. Measure the supply air static pressure and record this positive number.
2. Measure the return air static pressure and record this negative number.
3. The sum of the absolute values of two parameters is equal to the total static pressure.

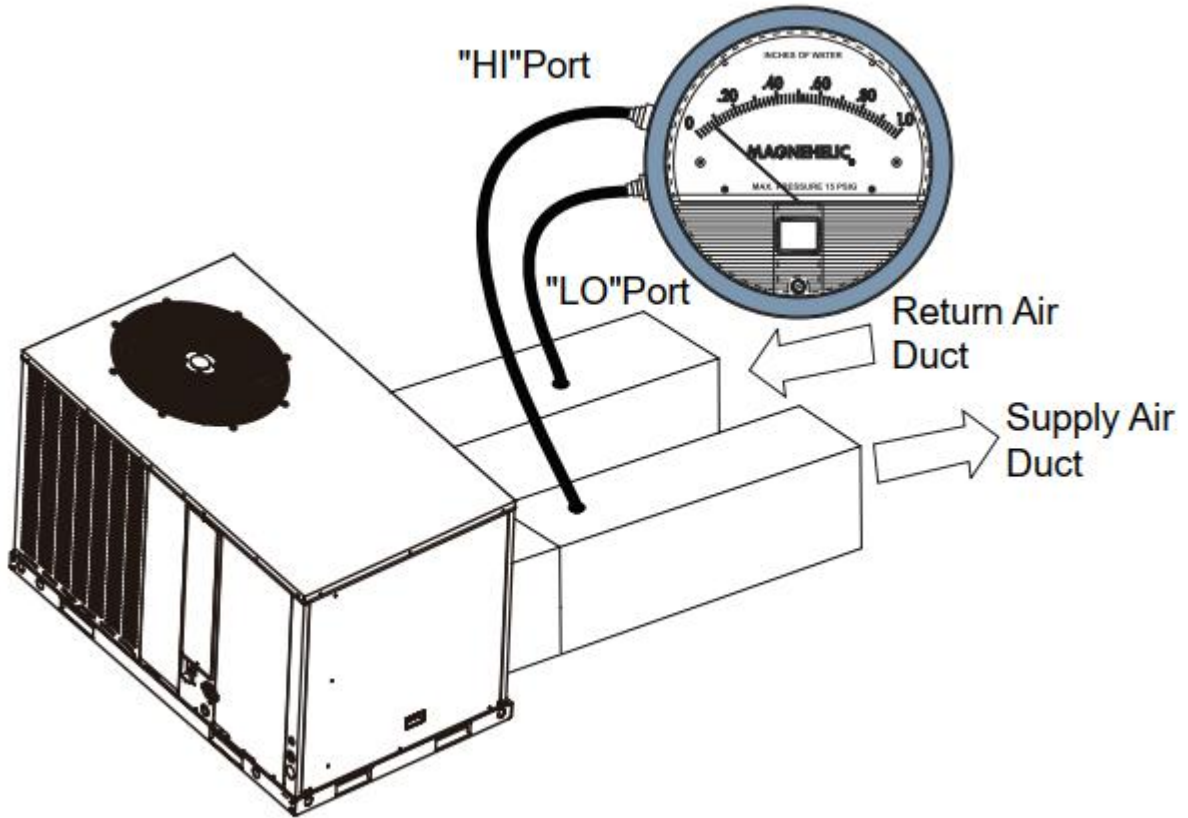

4.2.3 External Static Pressure Setup

Airflow performance data at different static pressures and wind ranges(208V):

Model Number	Motor Speed		SCFM								
			External Static Pressure in H ₂ O[kPa]								
			0[0]	0.1[.02]	0.2[.05]	0.3[.07]	0.4[.10]	0.5[.12]	0.6[.15]	0.7[.17]	0.8[.20]
24	Low-Tap(1)	SCFM	787	744	691	643	/	/	/	/	/
		Watts	187	185	182	152	/	/	/	/	/
		Amps	0.98	0.77	0.75	0.73	/	/	/	/	/
	Mid-Tap(2) (Factory)	SCFM	/	/	/	882	828	751	698	/	/
		Watts	/	/	/	269	262	253	246	/	/
		Amps	/	/	/	1.37	1.34	1.31	1.27	/	/
	High-Tap(3)	SCFM	/	/	/	/	/	964	896	759	621
		Watts	/	/	/	/	/	360	330	307	276
		Amps	/	/	/	/	/	1.78	1.71	1.64	1.57
30	Low-Tap(1)	SCFM	911	869	828	782	723	/	/	/	/
		Amps	0.9	1.0	1.0	1.1	1.2	/	/	/	/
		Watts	103	113	122	131	141	/	/	/	/
	Mid-Tap(2)	SCFM	/	1031	995	961	927	876	829	782	740
		Amps	/	1.3	1.4	1.5	1.6	1.7	1.7	1.8	1.9
		Watts	/	159	170	180	190	203	213	222	230
	High-Tap(3) (Factory)	SCFM	/	/	/	/	1079	1050	1015	967	926
		Amps	/	/	/	/	2.0	2.1	2.2	2.3	2.4
		Watts	/	/	/	/	246	257	270	286	297
36	Low-Tap(2)	SCFM	1073	1031	995	961	927	876	/	/	/
		Amps	1.2	1.3	1.4	1.5	1.6	1.7	/	/	/
		Watts	148	159	170	180	190	203	/	/	/
	Mid-Tap(3)	SCFM	/	1177	1142	1110	1079	1050	1015	967	926
		Amps	/	1.7	1.8	1.9	2.0	2.1	2.2	2.3	2.4
		Watts	/	209	221	233	246	257	270	286	297
	High-Tap(4) (Factory)	SCFM	/	/	/	/	/	1232	1205	1178	1152
		Amps	/	/	/	/	/	2.8	2.9	3.0	3.1
		Watts	/	/	/	/	/	347	361	374	386
42	Low-Tap(1) (Factory)	SCFM	1545	1507	1463	1418	1366	1307	1239	1144	/
		Watts	487	479	469	458	447	433	418	400	/
		Amps	2.58	2.55	2.52	2.49	2.46	2.42	2.38	2.33	/
	Mid-Tap(2)	SCFM	/	/	/	/	1551	1488	1414	1318	1200
		Watts	/	/	/	/	728	712	693	672	644
		Amps	/	/	/	/	4.1	4.05	3.99	3.92	3.84
	High-Tap(3)	SCFM	/	/	/	/	/	/	1570	1499	1380
		Watts	/	/	/	/	/	/	812	787	759
		Amps	/	/	/	/	/	/	4.57	4.49	4.4
48	Low-Tap(1)	SCFM	1545	1507	1463	1418	1366	1307	1239	/	/
		Watts	487	479	469	458	447	433	418	/	/
		Amps	2.58	2.55	2.52	2.49	2.46	2.42	2.38	/	/
	Mid-Tap(2) (Factory)	SCFM	1740	1699	1654	1606	1551	1488	1414	1318	1200
		Watts	783	768	756	742	728	712	693	672	644
		Amps	4.27	4.22	4.18	4.14	4.1	4.05	3.99	3.92	3.84
	High-Tap(3)	SCFM	/	/	/	1800	1740	1671	1595	1499	1380
		Watts	/	/	/	874	854	833	812	787	759
		Amps	/	/	/	4.76	4.7	4.63	4.57	4.49	4.4
60	Low-Tap(3) (Factory)	SCFM	1830	1784	1742	1700	1658	1618	1579	1542	1503
		Amps	2.4	2.5	2.7	2.8	2.9	3.0	3.1	3.2	3.3
		Watts	306	320	336	350	365	380	392	407	420
	Mid-Tap(4) (Factory)	SCFM	1983	1943	1906	1862	1824	1784	1745	1709	1674
		Amps	3.1	3.2	3.3	3.4	3.5	3.6	3.7	3.9	4.0
		Watts	391	406	421	438	453	469	486	501	515
	High-Tap(5)	SCFM	2250	2201	2159	2120	2083	2047	2023	1978	1946
		Amps	4.3	4.4	4.5	4.6	4.7	4.9	5.0	5.1	5.2
		Watts	562	575	593	609	627	645	666	682	700

4.2.3 External Static Pressure Setup

Airflow performance data at different static pressures and wind ranges(230V):

Model Number	Motor Speed		SCFM								
			External Static Pressure in H ₂ O[kPa]								
			0[0]	0.1[.02]	0.2[.05]	0.3[.07]	0.4[.10]	0.5[.12]	0.6[.15]	0.7[.17]	0.8[.20]
24	Low-Tap(1)	SCFM	885	841	795	743	/	/	/	/	/
		Watts	227	224	221	216	/	/	/	/	/
		Amps	2.07	2.07	2.06	2.05	/	/	/	/	/
	Mid-Tap(2) (Factory)	SCFM	/	/	/	988	957	882	767	/	/
		Watts	/	/	/	339	323	307	291	/	/
		Amps	/	/	/	2.31	2.28	2.26	2.24	/	/
	High-Tap(3)	SCFM	/	/	/	/	/	996	967	928	896
		Watts	/	/	/	/	/	412	392	379	361
		Amps	/	/	/	/	/	2.65	2.57	2.52	2.46
30	Low-Tap(1)	SCFM	911	869	828	782	723	/	/	/	/
		Amps	0.9	1.0	1.0	1.1	1.2	/	/	/	/
		Watts	103	113	122	131	141	/	/	/	/
	Mid-Tap(2)	SCFM	/	1031	995	961	927	876	829	782	740
		Amps	/	1.3	1.4	1.5	1.6	1.7	1.7	1.8	1.9
		Watts	/	159	170	180	190	203	213	222	230
	High-Tap(3) (Factory)	SCFM	/	/	/	/	1079	1050	1015	967	926
		Amps	/	/	/	/	2.0	2.1	2.2	2.3	2.4
		Watts	/	/	/	/	246	257	270	286	297
36	Low-Tap(2)	SCFM	1073	1031	995	961	927	876	/	/	/
		Amps	1.2	1.3	1.4	1.5	1.6	1.7	/	/	/
		Watts	148	159	170	180	190	203	/	/	/
	Mid-Tap(3)	SCFM	/	1177	1142	1110	1079	1050	1015	967	926
		Amps	/	1.7	1.8	1.9	2.0	2.1	2.2	2.3	2.4
		Watts	/	209	221	233	246	257	270	286	297
	High-Tap(4) (Factory)	SCFM	/	/	/	/	/	1232	1205	1178	1152
		Amps	/	/	/	/	/	2.8	2.9	3.0	3.1
		Watts	/	/	/	/	/	347	361	374	386
42	Low-Tap(1) (Factory)	SCFM	/	/	/	/	1554	1495	1429	1340	1230
		Watts	/	/	/	/	527	510	469	465	432
		Amps	/	/	/	/	2.29	2.22	2.15	2.02	1.88
	Mid-Tap(2)	SCFM	/	/	/	/	/	/	/	1503	1384
		Watts	/	/	/	/	/	/	/	566	533
		Amps	/	/	/	/	/	/	/	2.46	2.32
	High-Tap(3)	SCFM	/	/	/	/	/	/	/	/	1548
		Watts	/	/	/	/	/	/	/	/	662
		Amps	/	/	/	/	/	/	/	/	2.88
48	Low-Tap(1)	SCFM	1735	1701	1654	1608	1554	1495	1429	1340	/
		Watts	579	573	561	545	527	510	469	465	/
		Amps	2.52	2.49	2.44	2.37	2.29	2.22	2.15	2.02	/
	Mid-Tap(2) (Factory)	SCFM	/	/	/	1790	1730	1665	1591	1503	1384
		Watts	/	/	/	658	642	614	592	566	533
		Amps	/	/	/	2.86	2.79	2.67	2.57	2.46	2.32
	High-Tap(3)	SCFM	/	/	/	/	/	/	1761	1666	1548
		Watts	/	/	/	/	/	/	732	704	662
		Amps	/	/	/	/	/	/	3.18	3.06	2.88
60	Low-Tap(3) (Factory)	SCFM	1830	1784	1742	1700	1658	1618	1579	1542	1503
		Amps	2.4	2.5	2.7	2.8	2.9	3.0	3.1	3.2	3.3
		Watts	306	320	336	350	365	380	392	407	420
	Mid-Tap(4) (Factory)	SCFM	1983	1943	1906	1862	1824	1784	1745	1709	1674
		Amps	3.1	3.2	3.3	3.4	3.5	3.6	3.7	3.9	4.0
		Watts	391	406	421	438	453	469	486	501	515
	High-Tap(5)	SCFM	2250	2201	2159	2120	2083	2047	2023	1978	1946
		Amps	4.3	4.4	4.5	4.6	4.7	4.9	5.0	5.1	5.2
		Watts	562	575	593	609	627	645	666	682	700

PART 5 Intelligent Troubleshooting	38
5.1 Diagnosis System Introduction	39
5.1.1 System can't start	39
5.1.2 Abnormal system loud noise	40
5.1.3 Other common issues	40
5.2 Symptom-based Troubleshooting	41
5.2.1 DSP/LED1 OFF	41
5.2.2 System does not start operation(DSP shows "--")	42
5.2.3 Capacity is low	43
5.3 Troubleshooting by Module board Fault code.....	44
5.3.1 "E3" code	44
5.3.2 "E4" code	45
5.3.3 "P5" code	46
5.3.4 "AL" code	47
5.3.5 "P4" code	48
5.3.6 "P2" code	49
5.3.7 "E9" code	50
5.3.8 "H0" code	51
5.3.9 "E8" code	52
5.3.10 "n1X~n6X" code	53
5.4 Troubleshooting by Control board Fault code.....	54
5.4.1 "Keep flashing" code	54
5.4.2 "3 flash/cycle" code	55
5.4.3 "4 flash/cycle" code	56
5.4.4 "8 flash/cycle" code	57

Note: If the fault can not be resolved according to troubleshooting , please contact factory staff for help.

5.1 Abnormal system status checking guide

5.1.1 System can't start

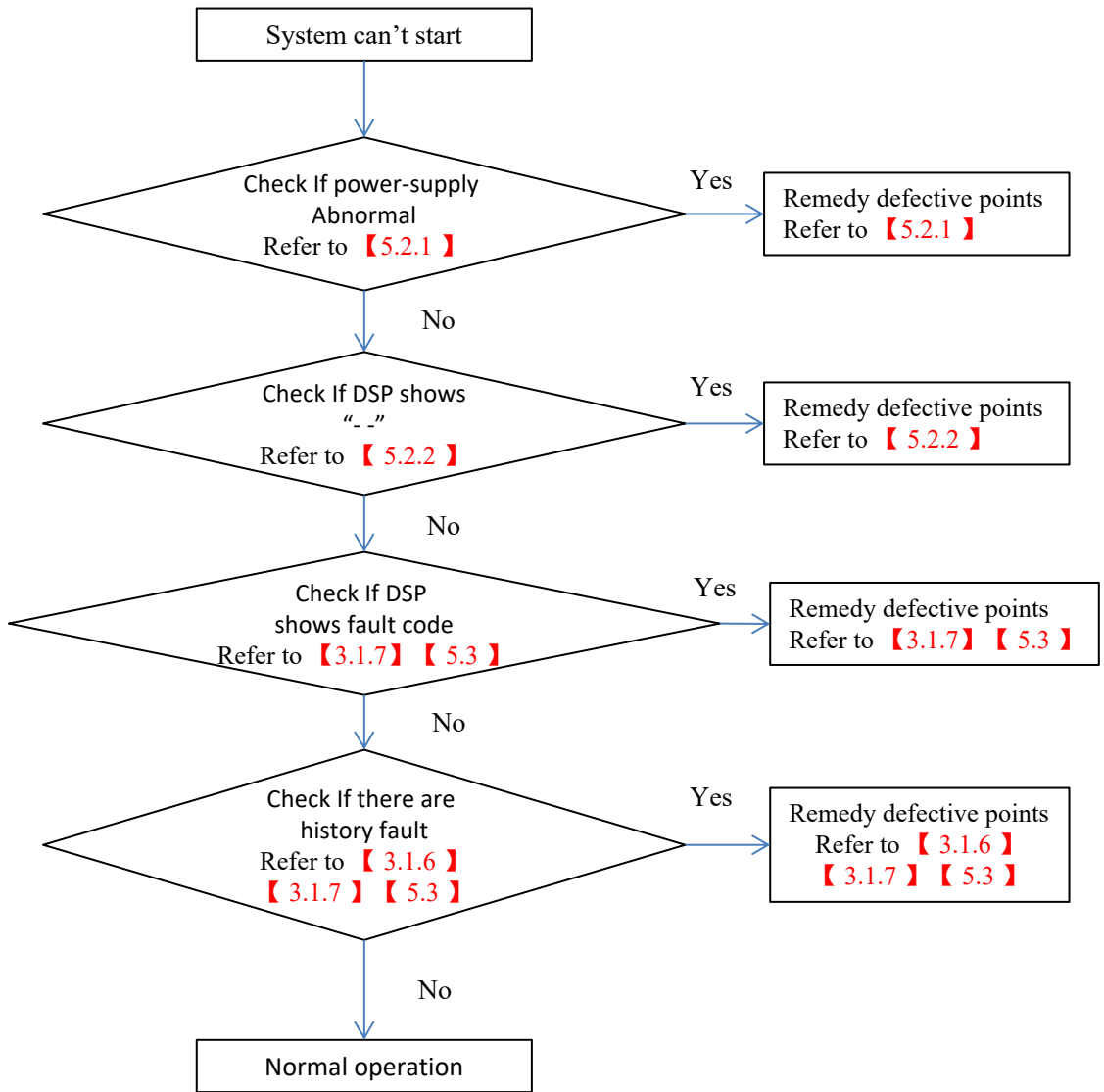

5.1 Abnormal system status checking guide

5.1.2 Abnormal system loud noise

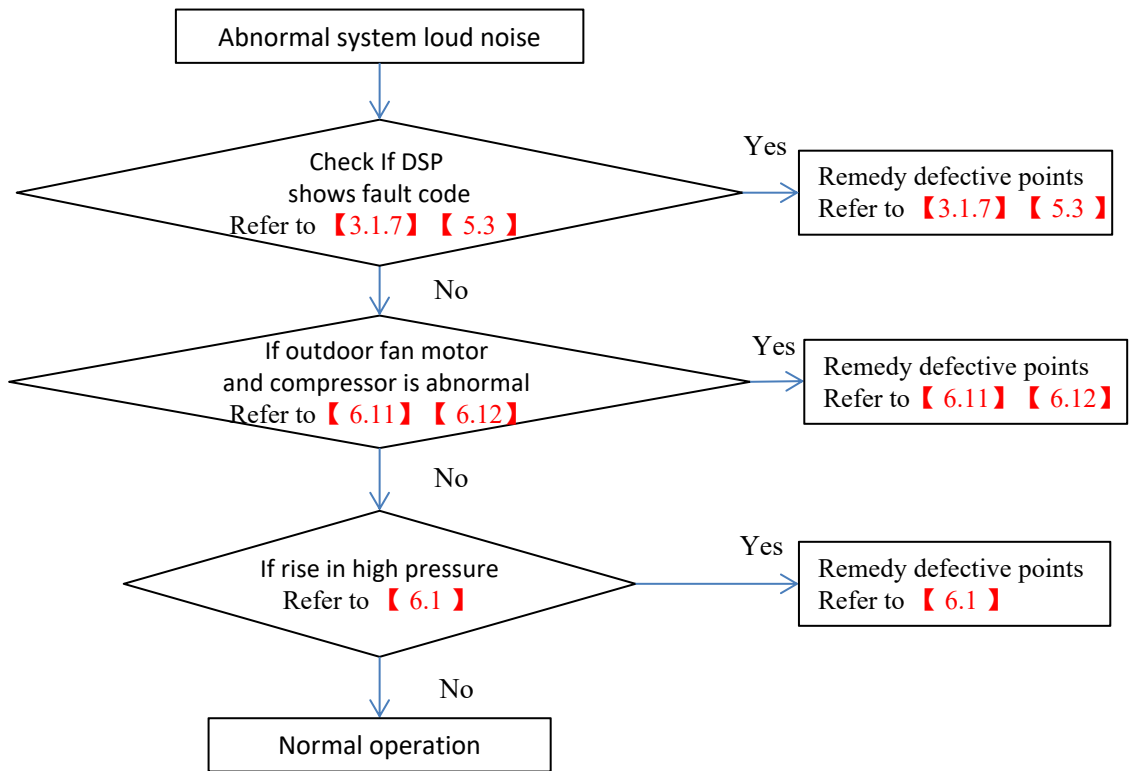

5.1.3 Other common issues

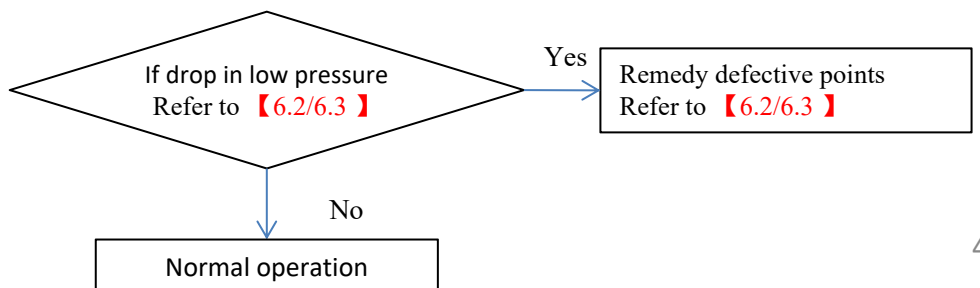
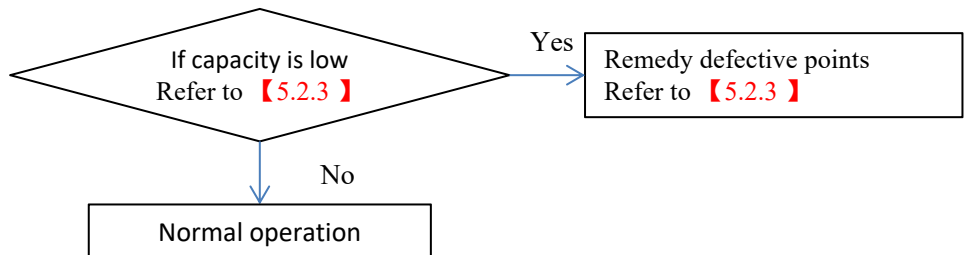
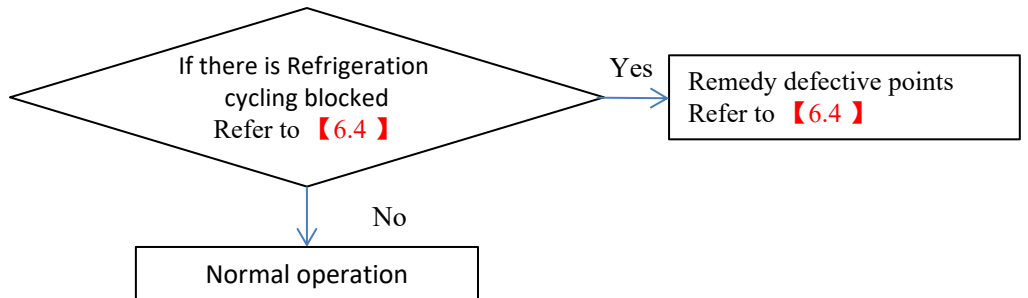

5.2 Symptom-based Troubleshooting

5.2.1 DSP/LED1(GREEN) of module board OFF

Issue	DSP/LED1(GREEN) of module board OFF
Model	All
Fault name	/
Classify	Power/electric issue
Possible cause	<ul style="list-style-type: none"> • Frequently power off and power on (within 3 minutes) • Abnormal power input • Abnormal wire connections

Troubleshooting

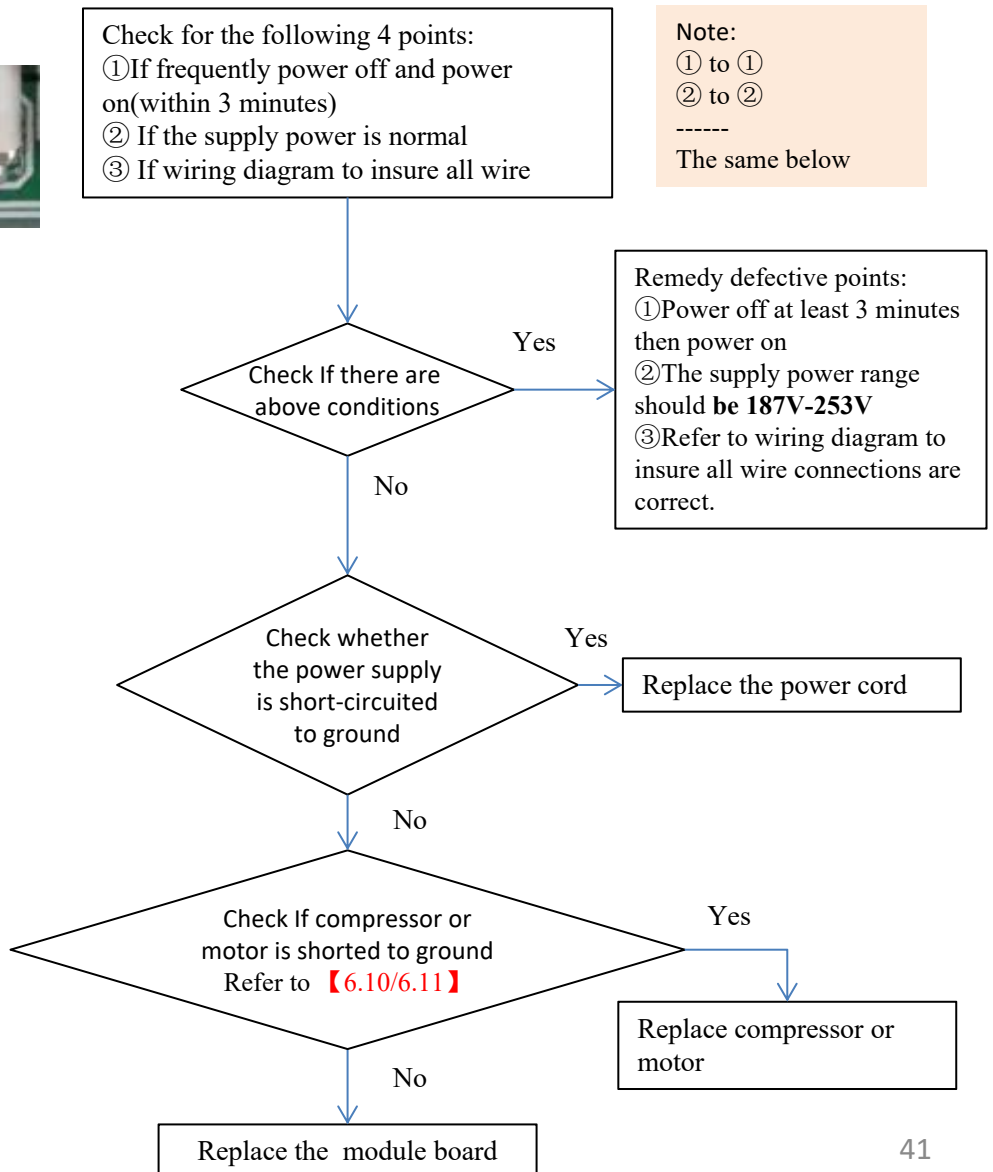

5.2 Symptom-based Troubleshooting

5.2.2 System does not start operation(DSP shows "--")

Issue	System does not start operation(DSP shows "--")
Model	All
Fault name	/
Classify	Thermostat fault
Possible cause	<ul style="list-style-type: none"> • The thermostat doesn't start • Wrong wire connections between thermostat and unit • Damaged thermostat • Module board or control board is damaged

Troubleshooting

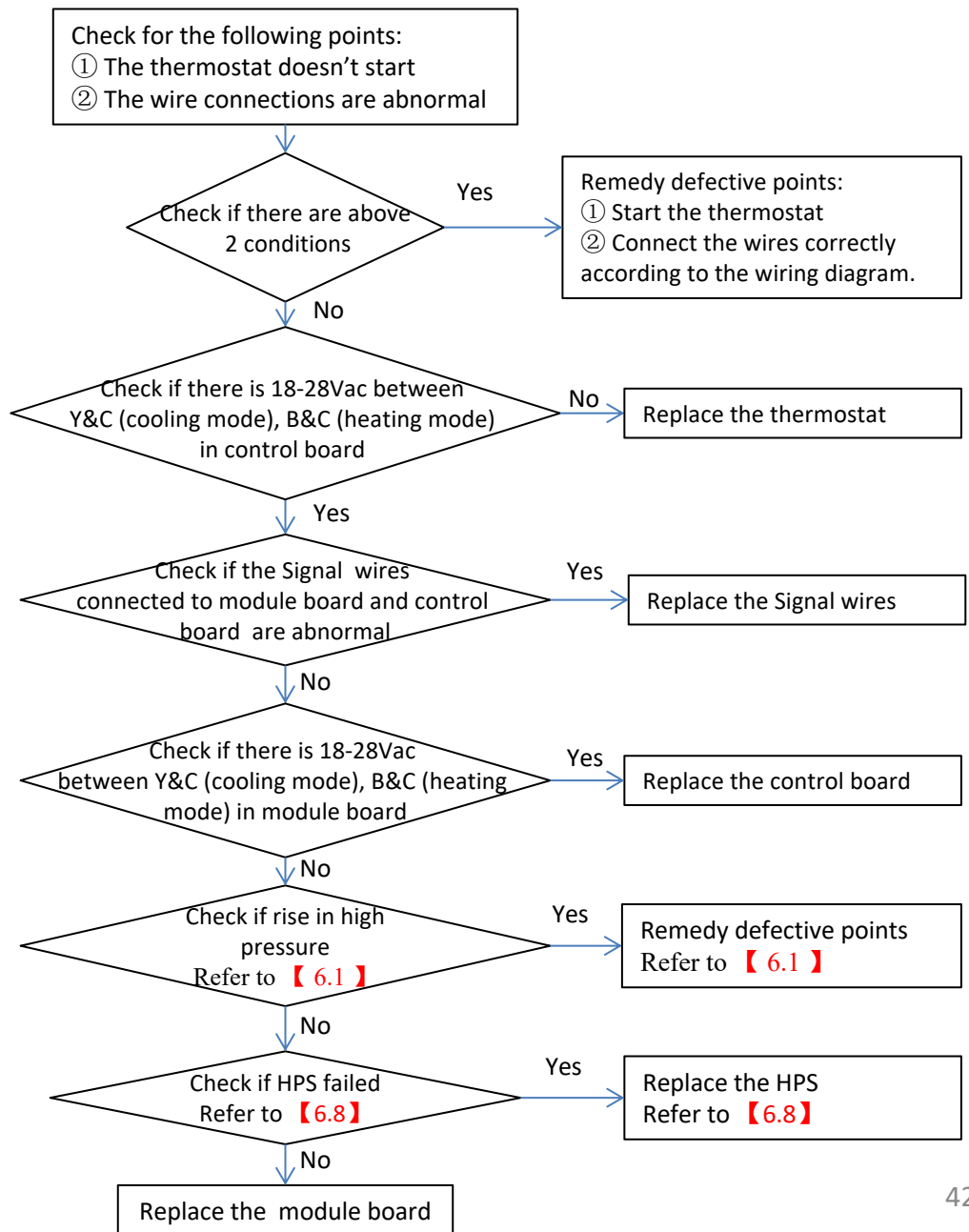

5.2 Symptom-based Troubleshooting

5.2.3 Capacity is low

Issue	Capacity is low
Model	All
Name	/
Classify	System fault
Possible cause	<ul style="list-style-type: none"> • Poor heat dissipation in unit • Under charged • First start

Troubleshooting

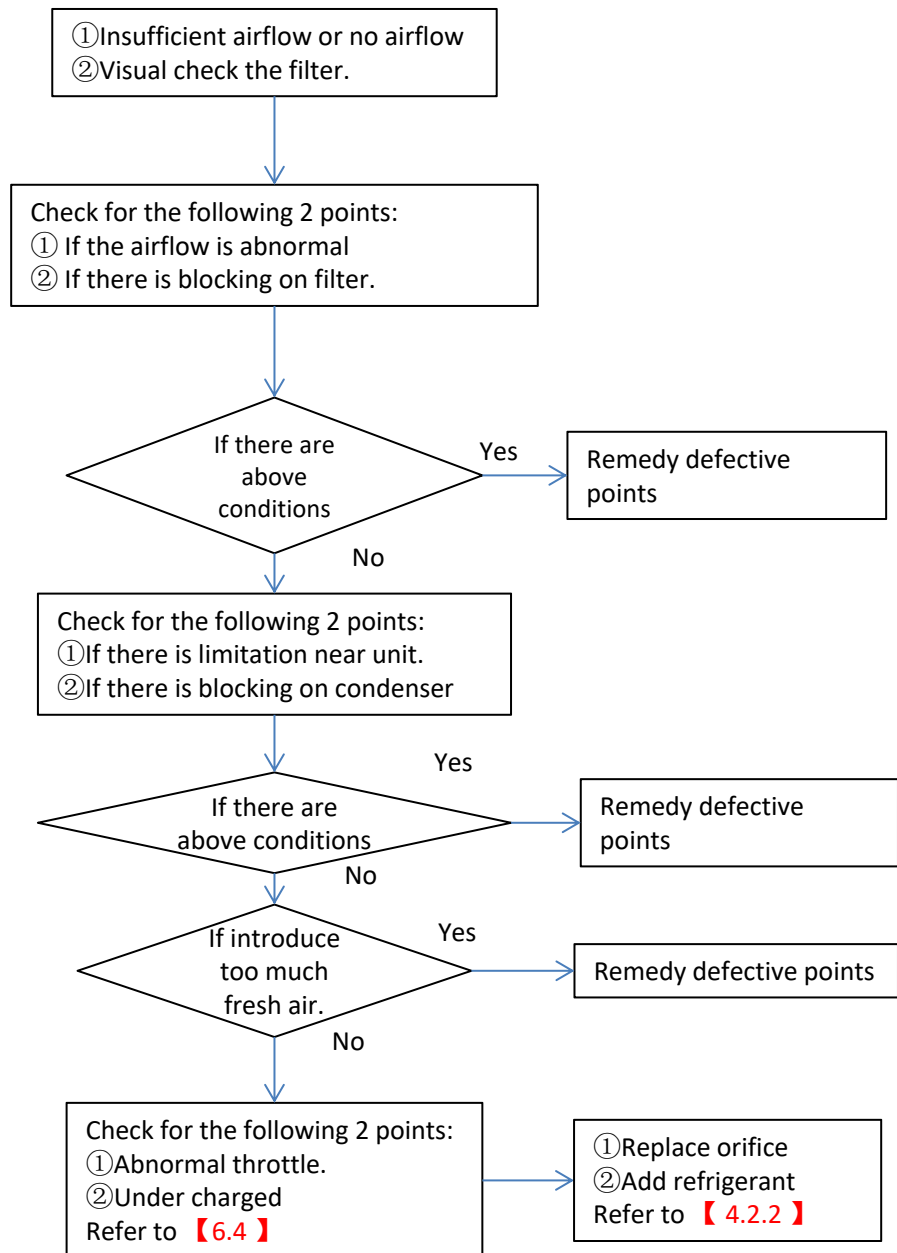

5.3 Troubleshooting by Module board Fault code

5.3.1 "E3" code

Faulty code	DSP shows "E3"
Model	All
Name	T3 sensor not reading correctly in cooling
Classify	System fault
Possible cause	<ul style="list-style-type: none">• Faulty T3 sensor

Troubleshooting

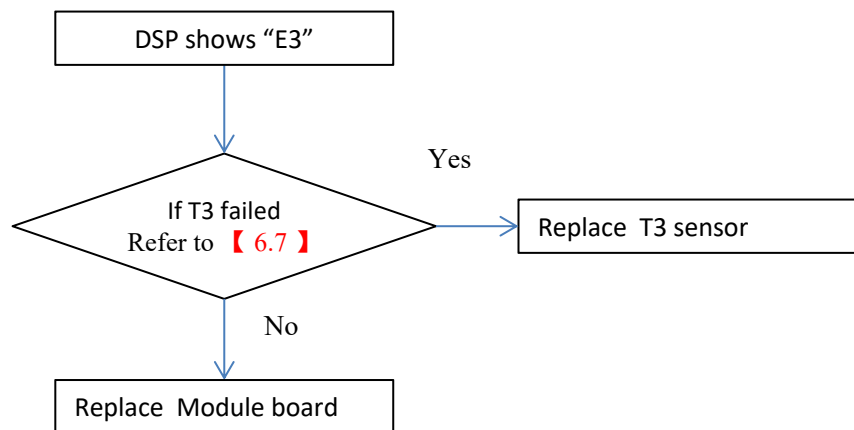

5.3 Troubleshooting by Module board Fault code

5.3.2 "E4" code

Faulty code	DSP shows "E4"
Model	All
Name	T4 sensor not reading correctly in cooling
Classify	System fault
Possible cause	<ul style="list-style-type: none">• Faulty T4 sensor

Troubleshooting

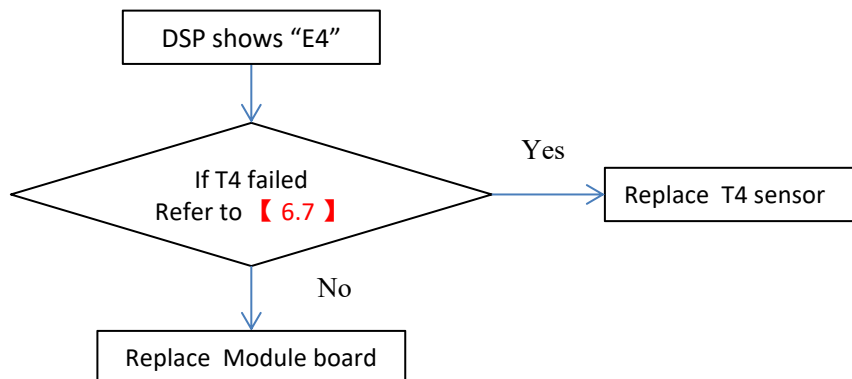

5.3 Troubleshooting by Module board Fault code

5.3.3 "P5" code

Faulty code	DSP shows "P5"
Model	All
Name	T3 sensor temperature is too high
Classify	System fault
Possible cause	<ul style="list-style-type: none"> • Wrong location of T3 sensor • Pipe bend or blocking • Multi-refrigerant • High ambient temp.

Troubleshooting

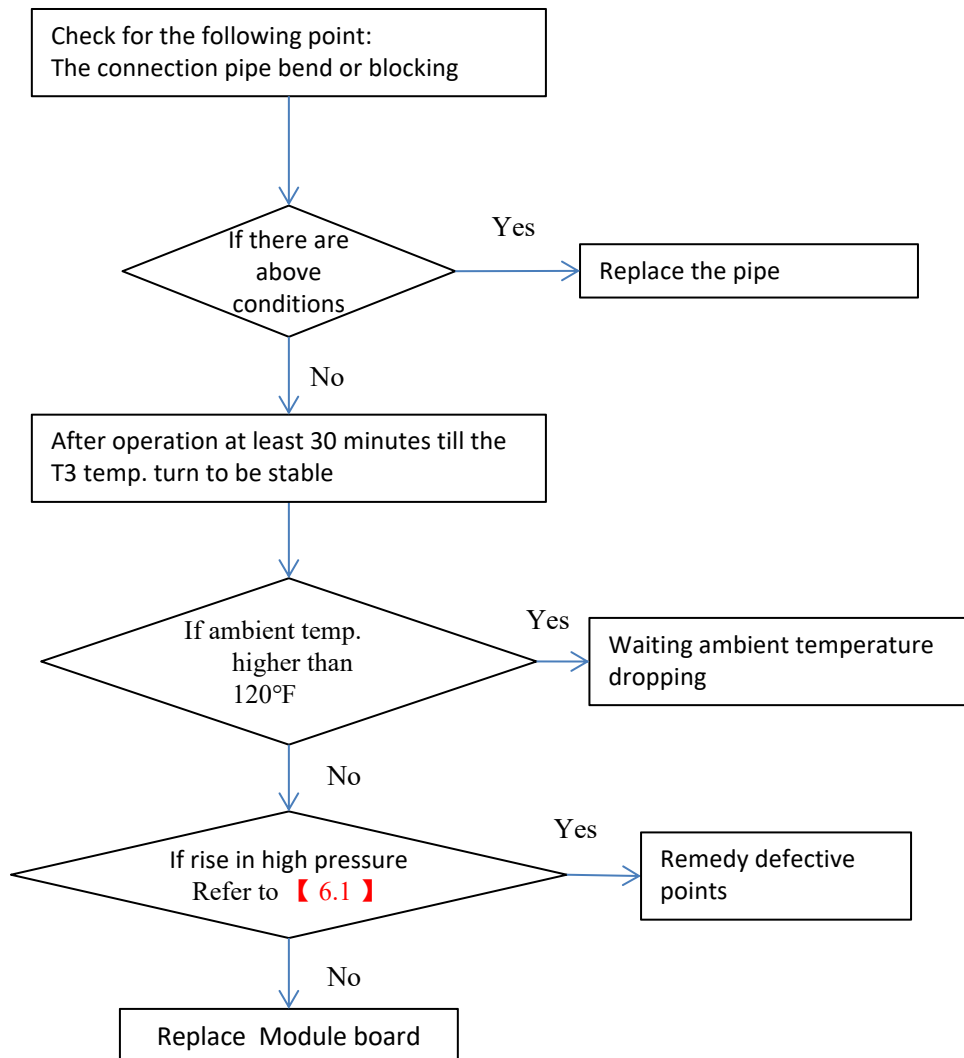

5.3 Troubleshooting by Module board Fault code

5.3.4 “AL” code

Faulty code	DSP shows “AL”
Model	All
Name	ambition temperature is beyond of the scope
Classify	System fault
Possible cause	<ul style="list-style-type: none"> • ambition temperature is beyond of the scope • Wrong location of T4 sensor

Troubleshooting

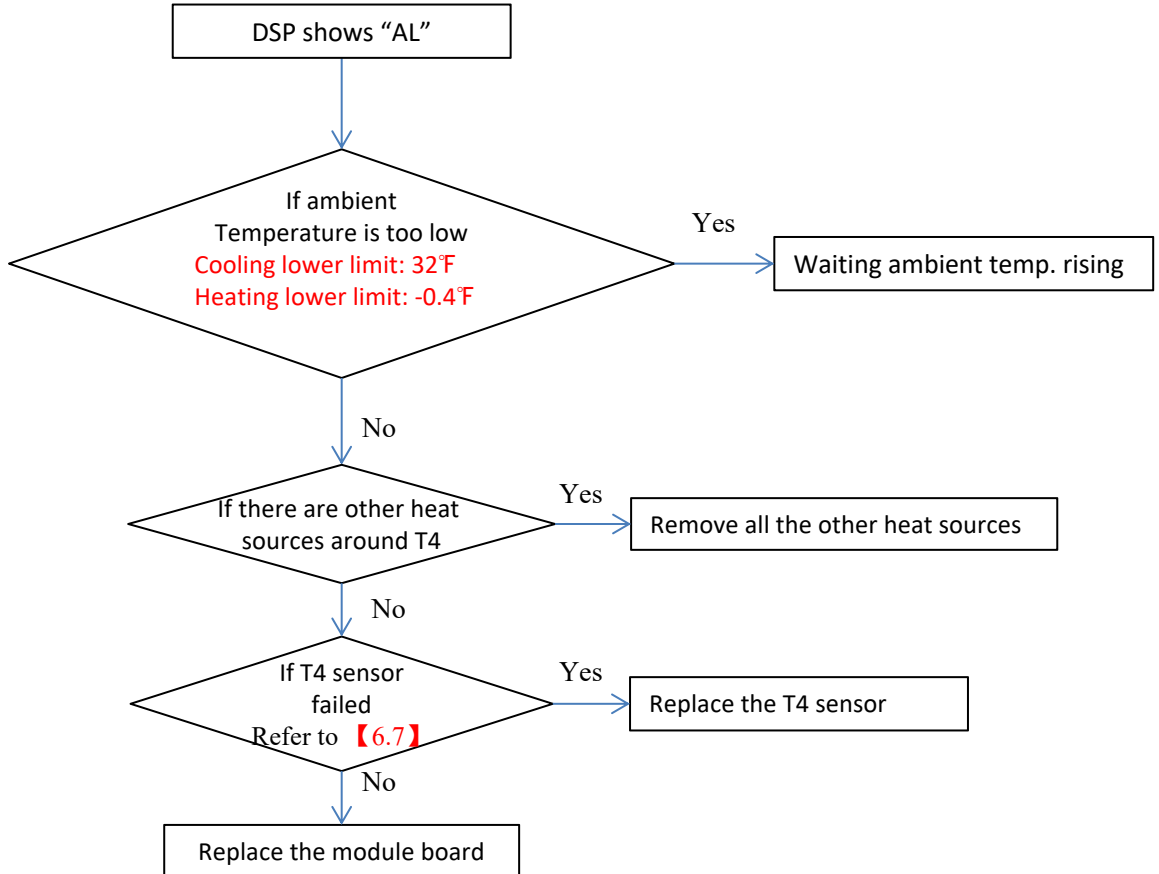

5.3 Troubleshooting by Module board Fault code

5.3.5 "P4" code

Faulty code	DSP shows "P4"
Model	All
Name	Compressor discharge temperature switch protection
Possible cause	<ul style="list-style-type: none"> • Filter blocked • Under charged • filter drier restriction • Indoor motor stopped abnormally • Poor heat exchange on indoor coil (heating mode) • Poor heat exchange on outdoor coil (cooling mode)

Troubleshooting

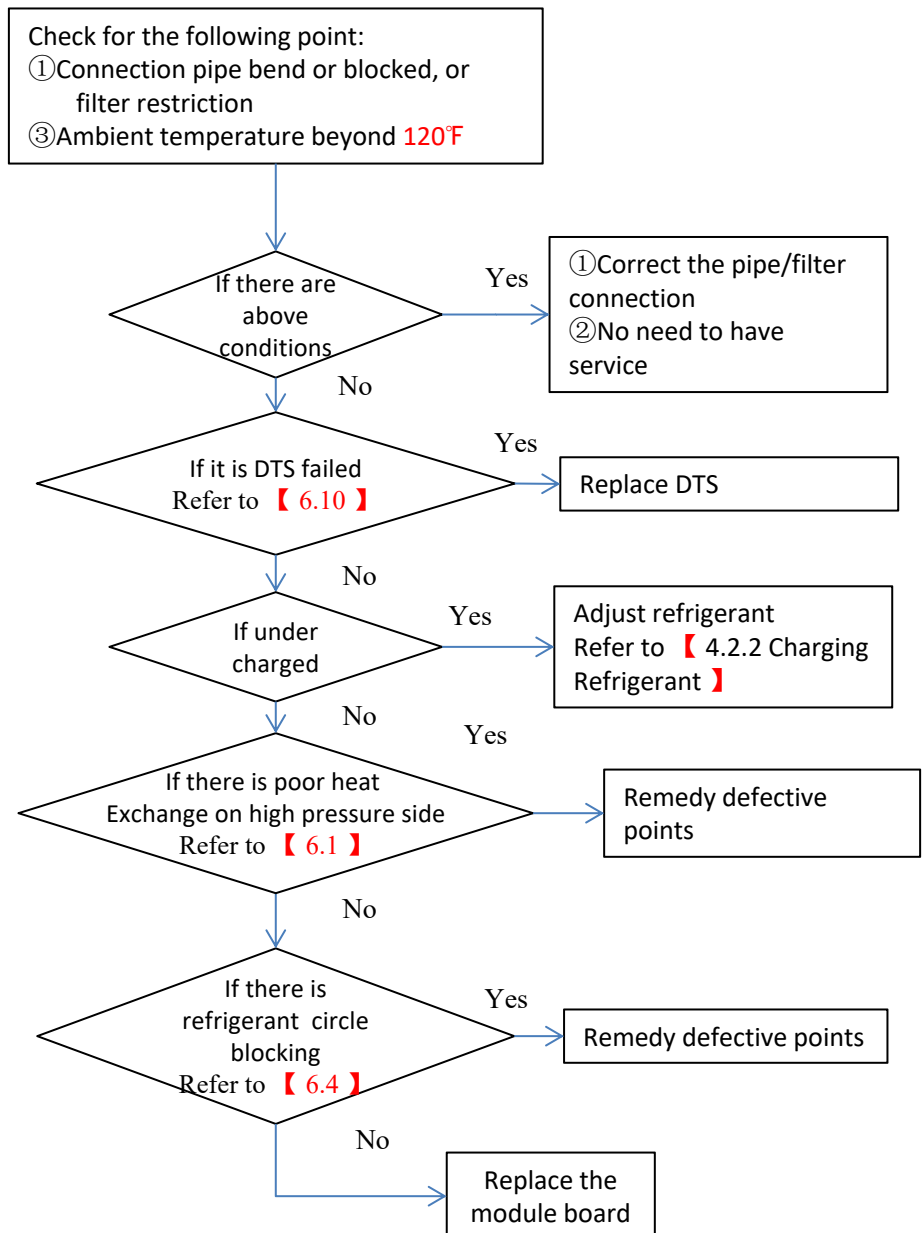

5.3 Troubleshooting by Module board Fault code

5.3.6 “P2” code

Faulty code	DSP shows “P2”
Model	All
Name	Low pressure protection
Classify	System fault
Possible cause	<ul style="list-style-type: none"> • Indoor motor stopped abnormally • Poor heat exchange on indoor coil (heating mode) • Poor heat exchange on outdoor coil (cooling mode) • Filter/orifice/coil blocked • Under charged

Troubleshooting

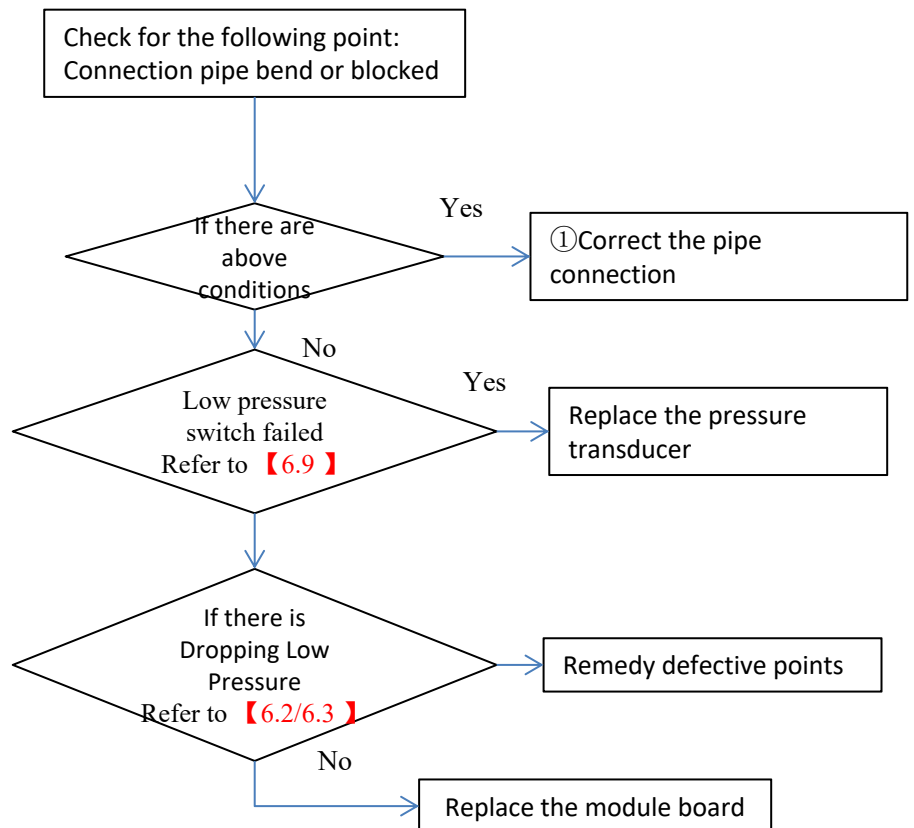

5.3 Troubleshooting by Module board Fault code

5.3.7 "E9" code

Faulty code	DSP shows "E9"
Model	All
Name	DC fan motor fault or Motor control failed
Classify	Electric issue
Possible cause	<ul style="list-style-type: none"> • Motor control failed • Motor failed

Troubleshooting

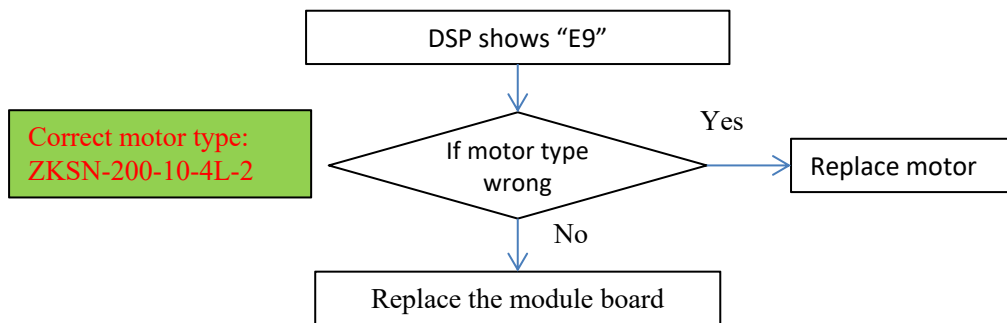

5.3 Troubleshooting by Module board Fault code

5.3.8 "H0" code

Faulty code	DSP shows "H0"
Model	All
Name	Communication fault between drive chip and main control chip
Classify	Electric issue
Possible cause	<ul style="list-style-type: none">•Program error•Module board is failure

Troubleshooting

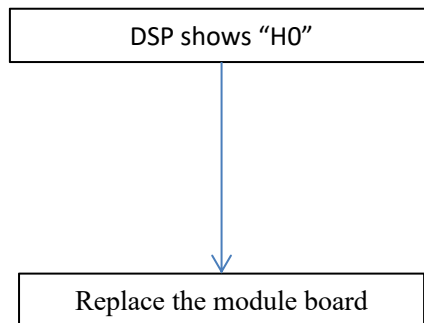

5.3 Troubleshooting by Module board Fault code

5.3.9 "E8" code

Faulty code	DSP shows "E8"
Model	All
Name	No machine type
Classify	Electric issue
Possible cause	<ul style="list-style-type: none">• Speed message isn't wrote in main board• Module board is failure

Troubleshooting

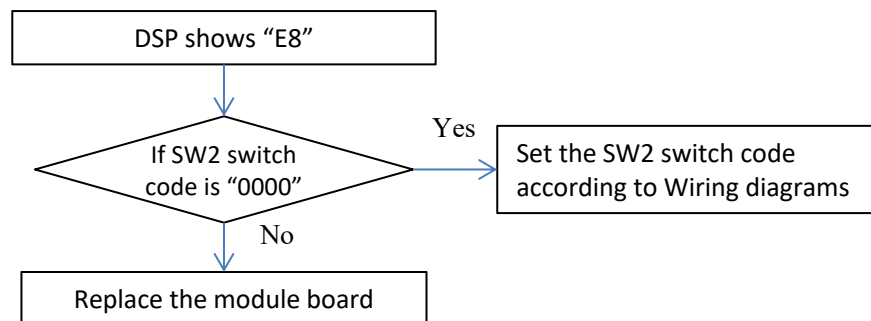

5.3 Troubleshooting by Module board Fault code

5.3.10 “n1X~n6X” code

Faulty code	DSP shows “n1X~n6X”
Model	All
Name	DC fan motor fault or Motor control failed
Classify	Electric issue
Possible cause	<ul style="list-style-type: none"> • Start electromagnetic interference • Motor failed • Motor control failed • Electric issue

Troubleshooting

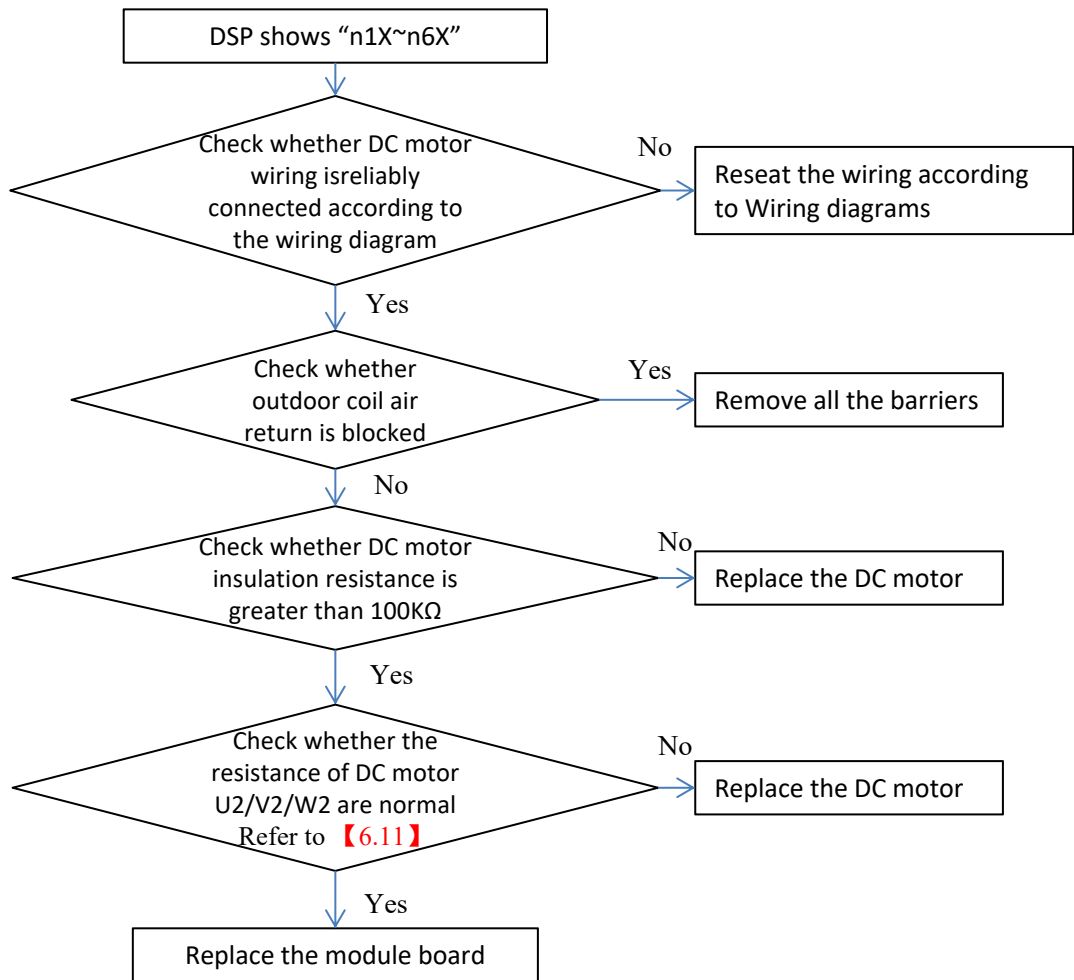
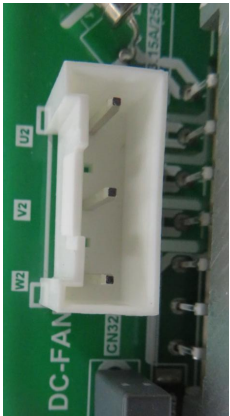

5.4 Troubleshooting by Control board Fault code

5.4.1 "Keep flashing" code

Faulty code	Keep flashing
Model	All
Name	Refrigerant leakage fault
Classify	Refrigerant leakage
Possible cause	<ul style="list-style-type: none"> • Refrigerant leakage

Troubleshooting

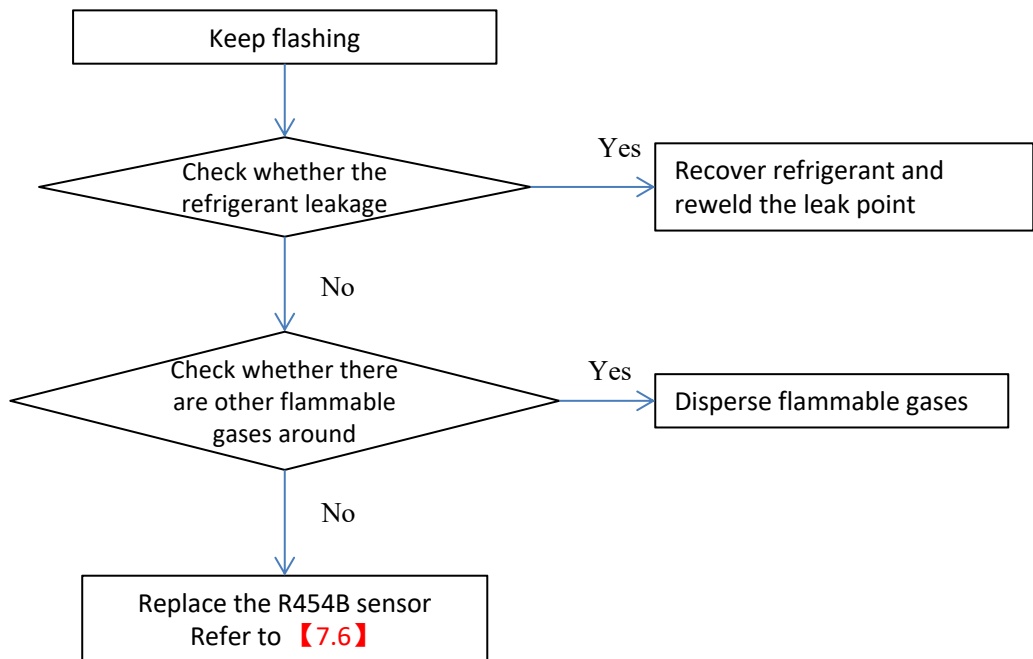

5.4 Troubleshooting by Control board Fault code

5.4.2 "3 flash/cycle" code

Faulty code	3 flash/cycle
Model	All
Name	R454B sensor fault
Classify	Sensor fault
Possible cause	<ul style="list-style-type: none">• Sensors failed• Beyond the normal operating temperature range

Troubleshooting

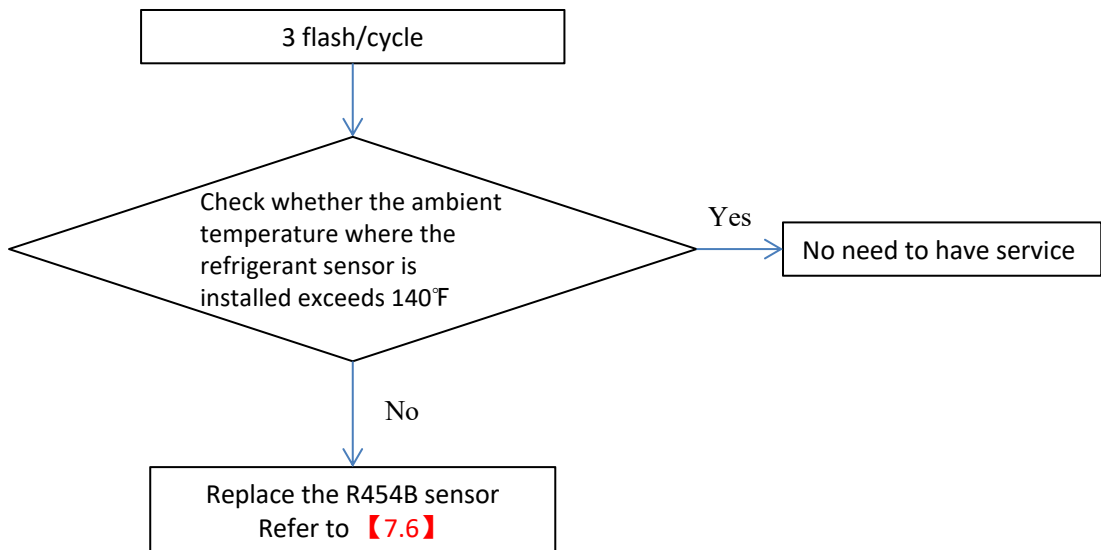

5.4 Troubleshooting by Control board Fault code

5.4.3 "4 flash/cycle" code

Faulty code	4 flash/cycle
Model	IDU
Name	R454B sensor communication fault
Classify	Electric issue
Possible cause	<ul style="list-style-type: none"> • Refrigerant sensor line connection abnormal: refrigerant sensor signal line is not properly plugged (CN26) • Refrigerant sensor abnormal: damaged

Troubleshooting

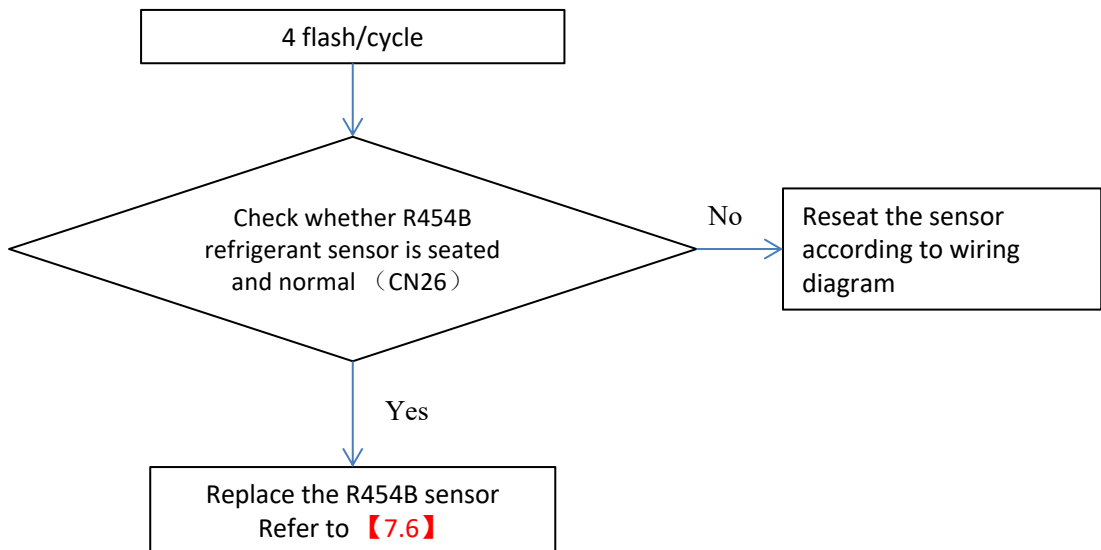

5.4 Troubleshooting by Control board Fault code

5.4.4 "8 flash/cycle" code

Faulty code	8 flash/cycle
Model	All
Name	R454B sensor over service life
Classify	Sensor fault
Possible cause	<ul style="list-style-type: none">• Over service

Troubleshooting

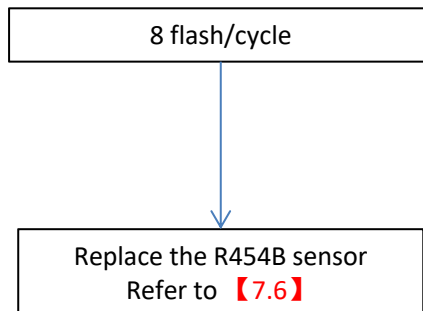

PART 6 Check	58
6.1 Check for Causes of Rise in High Pressure	59
6.2 Check for Causes of Dropping Low Pressure in Cooling	60
6.3 Check for Causes of Dropping Low Pressure in Heating	61
6.4 Check for Causes of Refrigeration cycling Blocked	62
6.5 Check for Module Board	63
6.6 Check for Control Board	65
6.7 Check for Temperature Sensor (T3/T4)	67
6.8 Check for High Pressure Switch (HPS)	68
6.9 Check for Low Pressure Switch (LPS)	69
6.10 Check for Discharge Temperature Switch (DTS)	70
6.11 Check for Outdoor Fan Motor	71
6.12 Check for Compressor Check	72
6.13 Check for indoor PSC unit status	73
6.14 Check for indoor ECM unit status	74
6.15 Check for Outdoor fan motor Speed	75
6.16 Check for FUSE	76

CHECK 1 6.1 Check for Causes of Rise in High Pressure

Note: 310-380PSIG head pressure is normal for heating in normal conditions operation. The pressure may be as high as 440PSIG at 40°F outdoor temperature or higher. Start-up or return oil stages during heating.

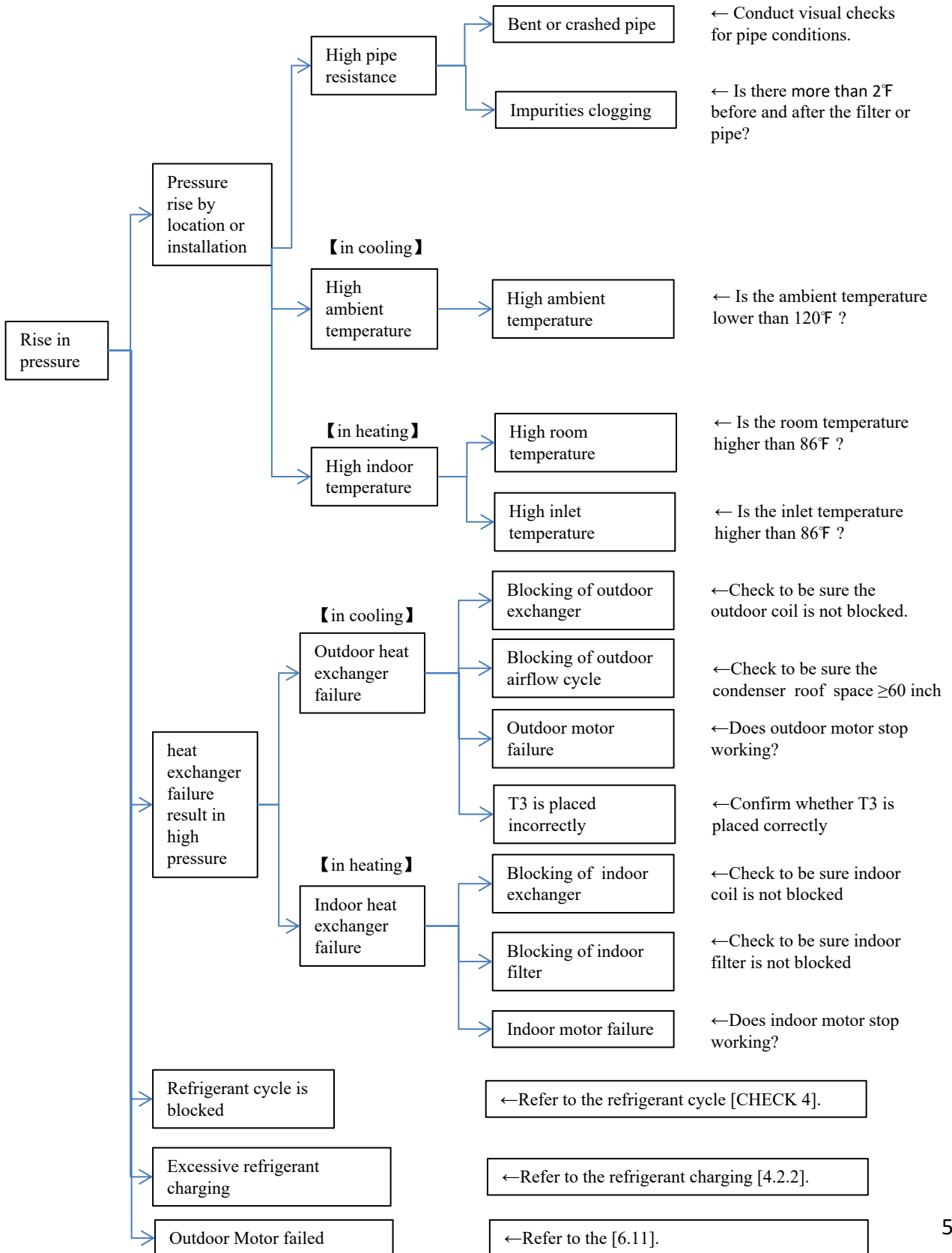

CHECK 2 6.2 Check for Causes of Dropping Low Pressure in cooling

Note: 110-140PSIG head pressure is normal in cooling conditions. The value may be lower/higher at maximum/minimum/limited frequency of compressor operation . Start-up or return oil stages.

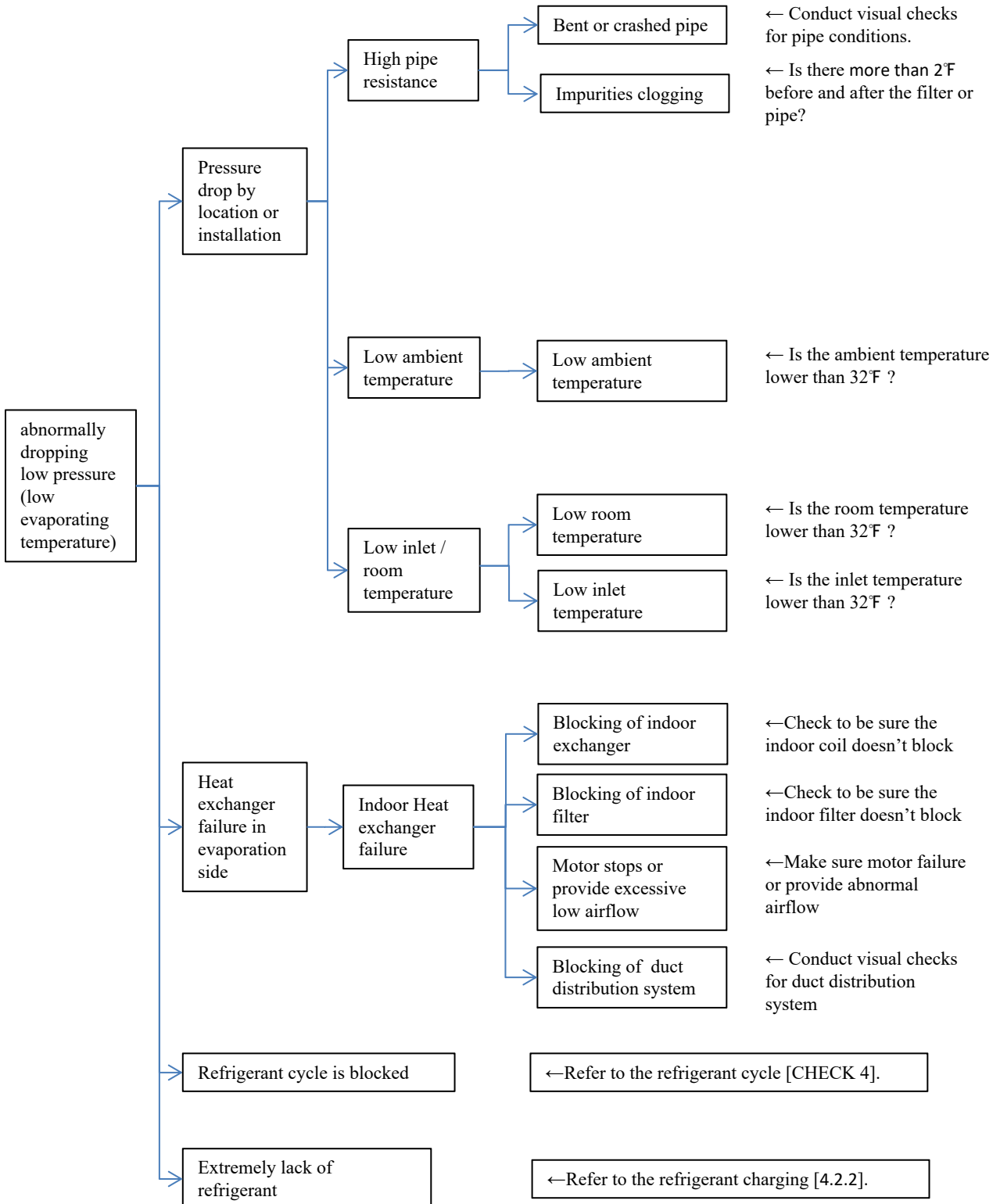

CHECK 3

6.3 Check for Causes of Dropping Low Pressure in heating

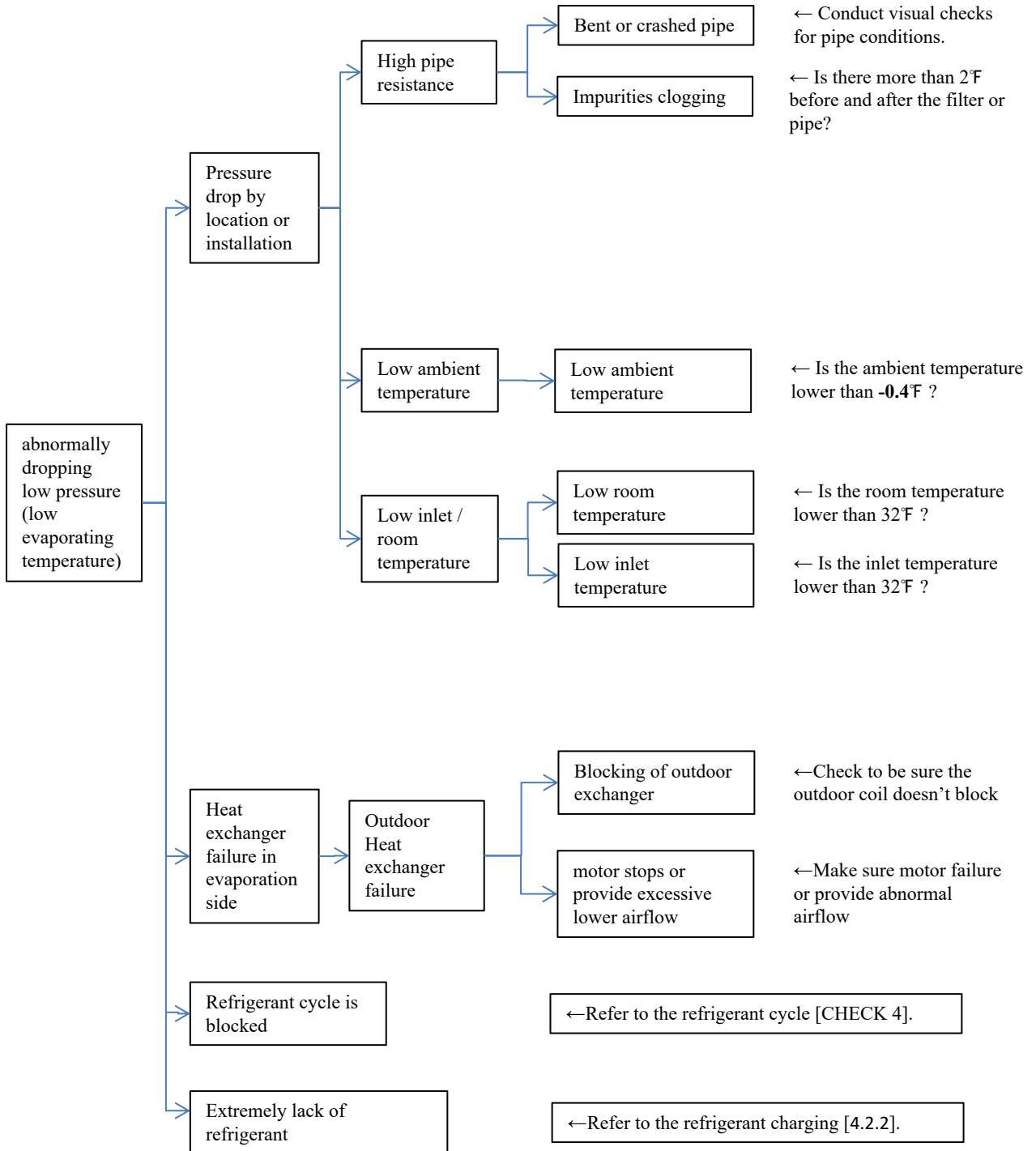

CHECK 4

6.4 Check for Causes of Refrigeration cycling blocked

Note: Check at normal and force mode operation, some problems will be more obvious.

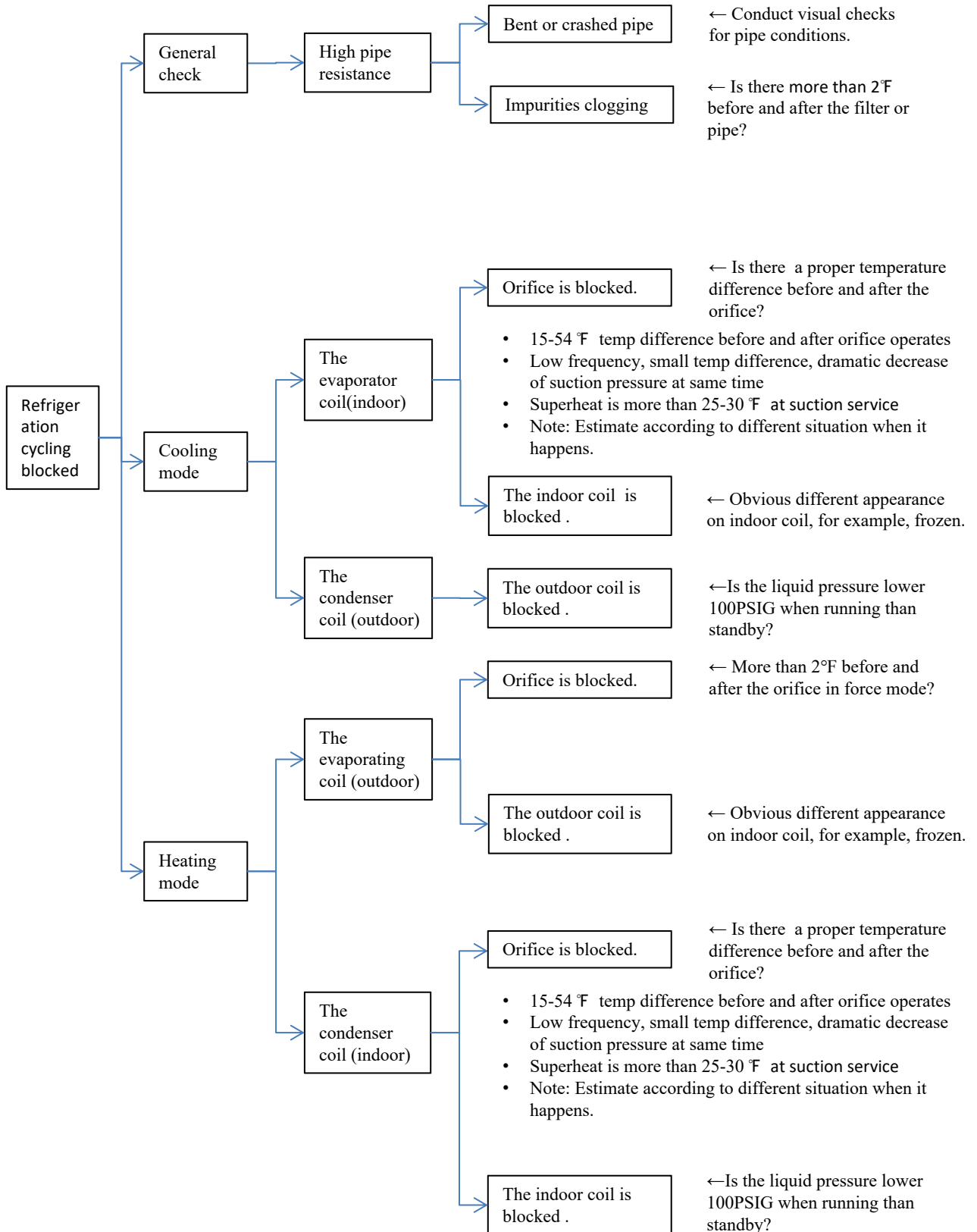

CHECK 5

6.5 Check for Module Board for 24K,30K,36K

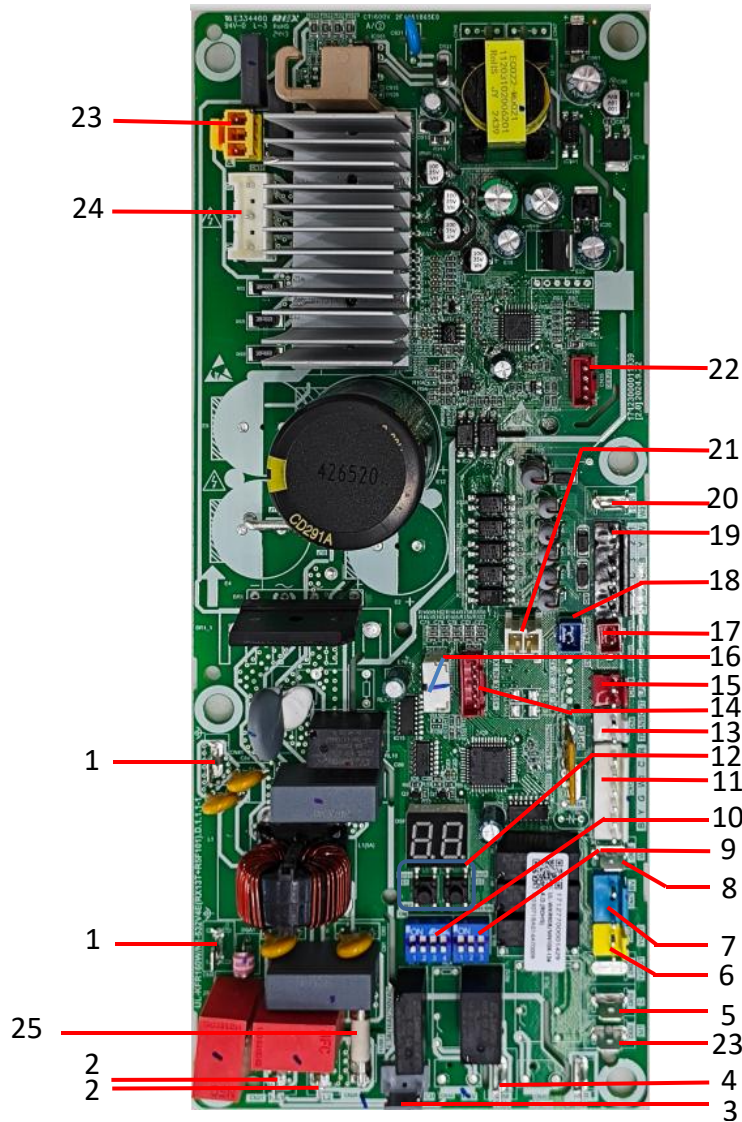

Label	Port Code	Content	Port Voltage
1	CN41/CN42	Earth port	0V
2	CN21/CN29	Power port	208/230V AC
3	CN45	Compressor crankcase heater port(Reserve)	0-24V AC
4	CN18	Indoor fan output port	208/230V AC
5	CN10	24VAC common port	0-24V AC
6	CN25	Compressor contactor control port	0-24V AC
7	CN47	Reversing Valve port	0-24V AC
8	CN23	W1 signal port	0-24V AC
9	SW1-3	SW1-3 dip switch : defrost logic setting	0-5V DC
10	SW2	Capacity setting	0-5V DC
11	CN12	Conventional 24VAC control wires port	0-24V AC
12	S1/S2	Force and check	0-5V DC
13	CN8	24 VAC input port	0-24V AC
14	CN34	Message port	0-5V DC
15	CN28	Low Pressure switch port	0-5V DC
16	CN38	Module board debug port	0-5V DC
17	CN39	T3 sensor port	0-5V DC
18	CN40	T4 sensor port	0-5V DC
19	CN7	Indoor fan motor control port	0-24V AC
20	CN31	W2 signal port	0-24V AC
21	CN5	Discharge temperature switch port	0-5V DC
22	CN35	Motor drive debug port	0-5V DC
23	CN44	Reserve	0-325V DC
24	CN37	DC motor port	0-325V DC
25	/	FUSE	208/230V AC

CHECK 5

6.5 Check for Module Board for 42K,48K,60K

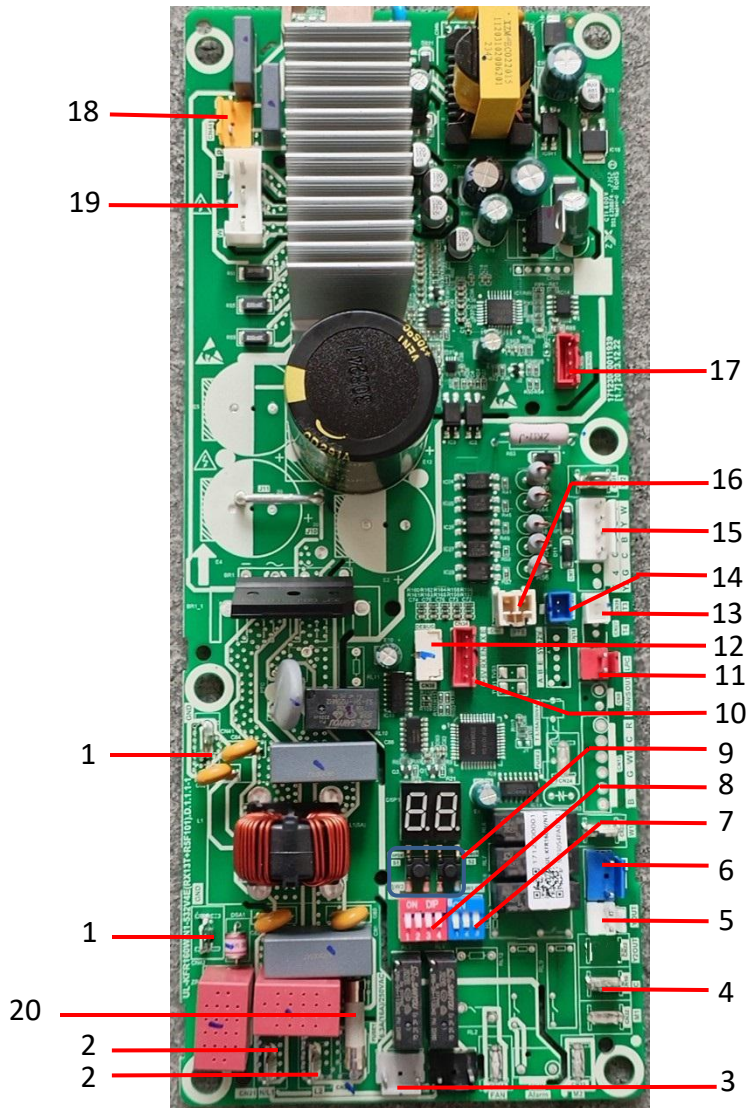

Label	Port Code	Content	Port Voltage
1	CN41/CN42	Earth port	0V
2	CN21/CN29	Power port	208/230V AC
3	CN45	Compressor crankcase heater port (Reserve)	0-24V AC
4	CN10	24VAC common port	0-24V AC
5	CN25	Compressor contactor control port	0-24V AC
6	CN47	Reversing Valve port	0-24V AC
7	SW1	SW1-3 dip switch : defrost logic setting	0-5V DC
8	SW2	Capacity setting	0-5V DC
9	S1/S2	Force and check	0-5V DC
10	CN34	Message port	0-5V DC
11	CN28	Low Pressure switch port	0-5V DC
12	CN38	Module board debug port	0-5V DC
13	CN39	T3 sensor port	0-5V DC
14	CN40	T4 sensor port	0-5V DC
15	CN7	Conventional 24VAC control wires port	0-24V AC
16	CN5	Discharge temperature switch port	0-5V DC
17	CN35	Motor drive debug port	0-5V DC
18	CN44	Reserve	0-325V DC
19	CN37	DC motor port	0-325V DC
20	/	FUSE	208/230V AC

CHECK 6

6.6 Check for Control Board

PCB Board for PSC motor (FOR 42/48K)

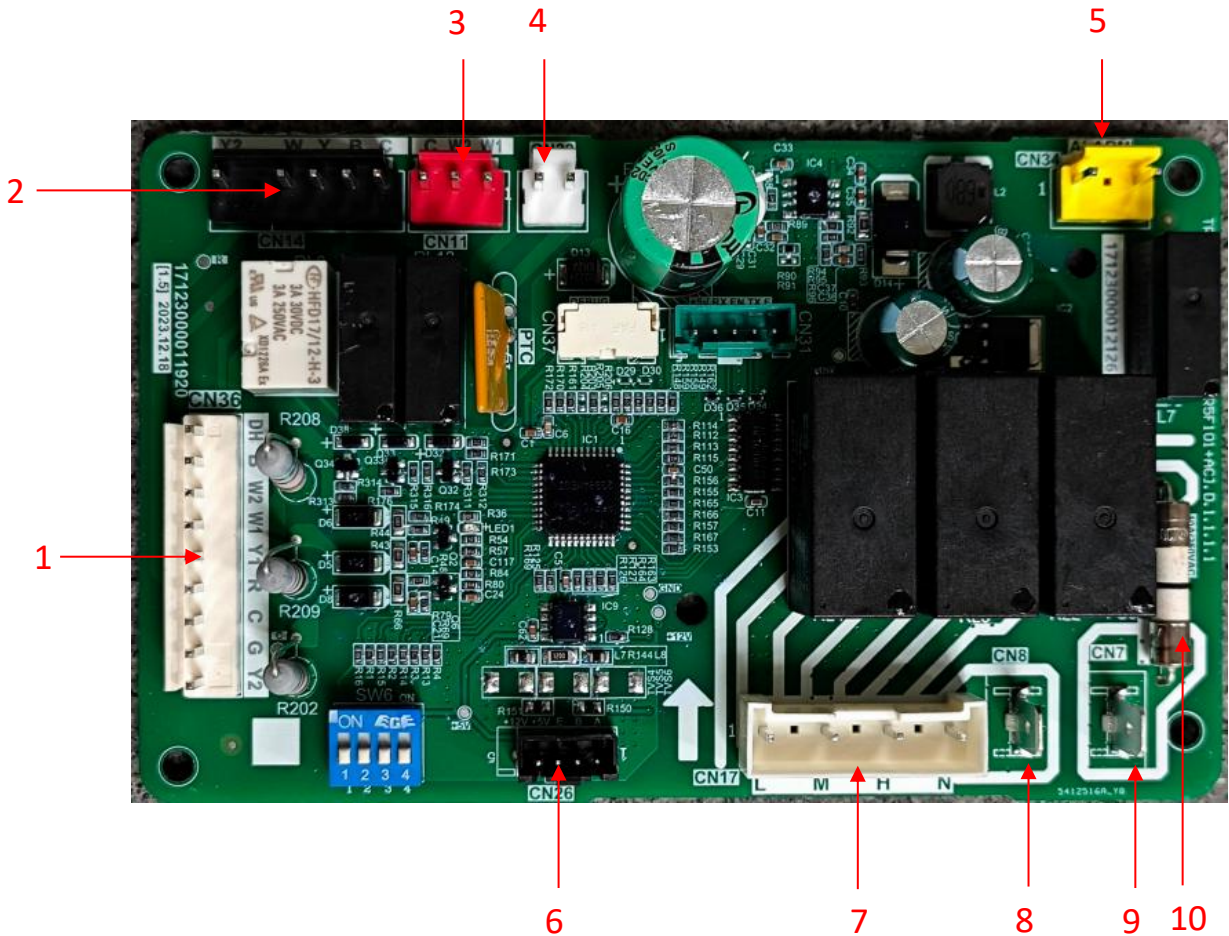

Label	Port Code	Content	Port Voltage
1	CN36	Thermostat wire connections	0-24V AC
2	CN14	Module board control port	0-24V AC
3	CN11	Heating kit control port	0-24V AC
4	CN33	Transformer output	0-24V AC
5	CN34	Alarm connection (Reserve)	0-12V AC
6	CN26	R454B refrigerant sensor port	0-5V AC
7	CN17	Indoor fan motor control port	208-230V AC
8	CN8	Power in (L2)	208-230V AC
9	CN7	Power in (L1)	208-230V AC
10	/	FUSE	208-230V AC

CHECK 6

6.6 Check for Control Board

PCB Board for ECM motor (For 60K)

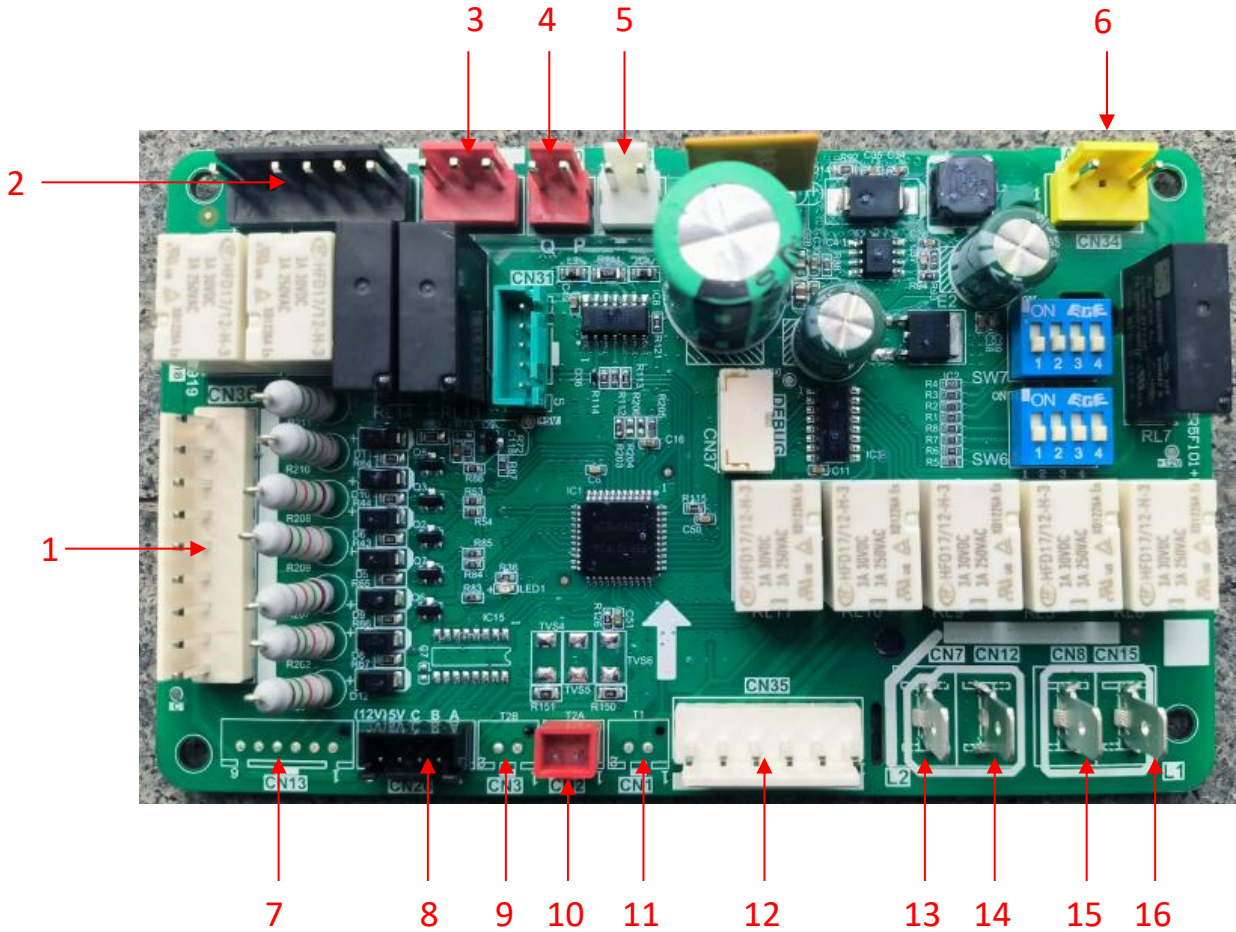

Label	Port Code	Content	Port Voltage
1	CN36	Thermostat wire connections	0-24V AC
2	CN14	Module board control port	0-24V AC
3	CN11	Heating kit control port	0-24V AC
4	CN30	Communication port (Reserve)	0-5V AC
5	CN33	Transformer output	0-24V AC
6	CN34	Alarm connection (Reserve)	0-12V AC
7	CN13	EEV port (Reserve)	0-12V AC
8	CN26	R454B refrigerant sensor port	0-5V AC
9	CN3	T2B sensor port (Reserve)	0-5V AC
10	CN2	T2 sensor port (Reserve)	0-5V AC
11	CN1	T1 sensor port (Reserve)	0-5V AC
12	CN35	Indoor fan motor control port	0-24V AC
13	CN7	Power in (L2)	208-230V AC
14	CN12	Power in (L2)	208-230V AC
15	CN8	Power in (L1)	208-230V AC
16	CN15	Power in (L1)	208-230V AC

CHECK 7 6.7 Check for Temperature Sensor (T3/T4)

Check temp transducer (T3/T4) :

Compare the temperature checked (T3/T4), it's normal if the temperature difference was within 15°F when standby.

T3/T4: 77 °F --10KΩ

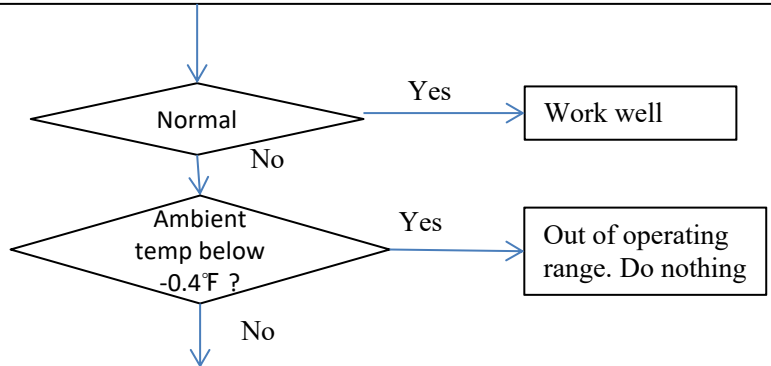

When power off and sensor unplugged

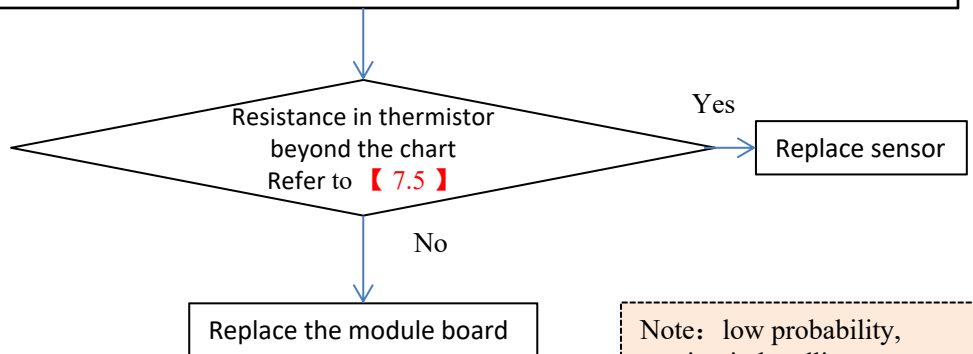
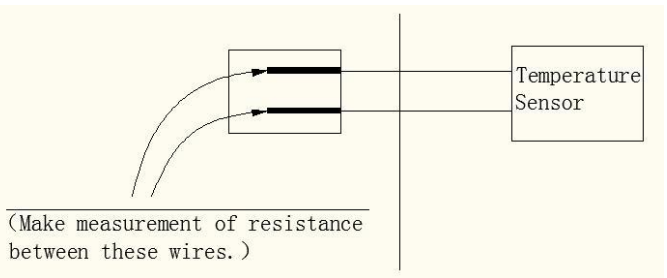

Note: low probability, caution in handling

CHECK 8

6.8 Check for High Pressure Switch (HPS)

High Pressure Switch :
Whether the switch can start normally when start the machine

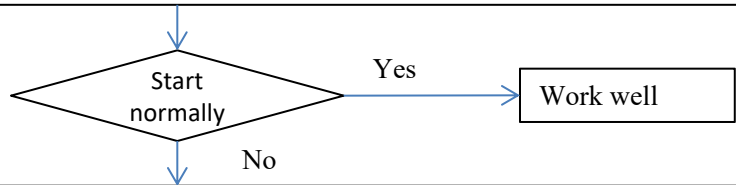

When power off and pull up

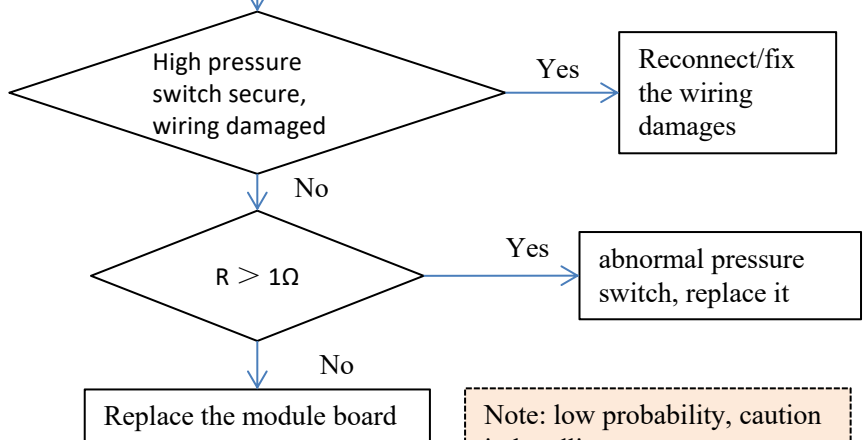
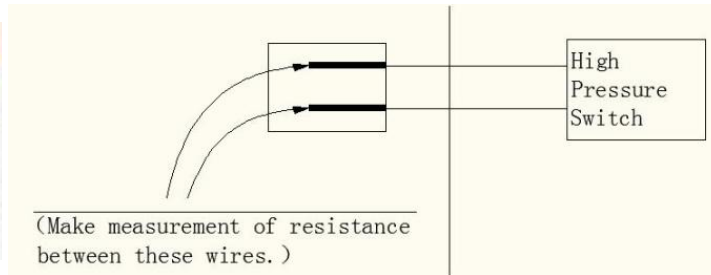

Note:
Normal high pressure switch opens above 580PSIG, resets below 435PSIG.

Note: low probability, caution in handling

CHECK 9

6.9 Check for Low Pressure Switch (LPS)

Low Pressure Switch :
Whether the switch can start normally when start the machine

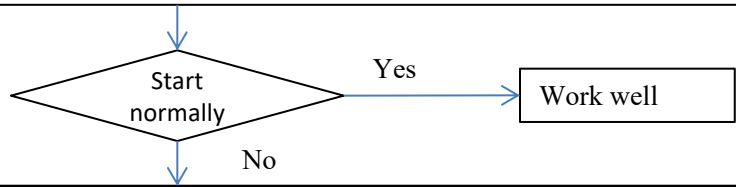

When power off and pull up

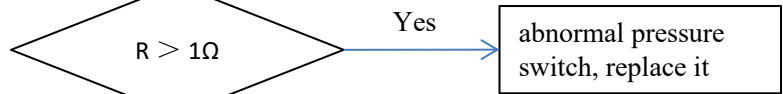
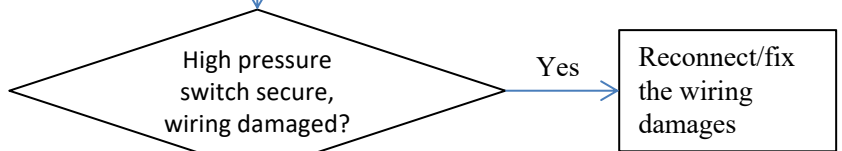
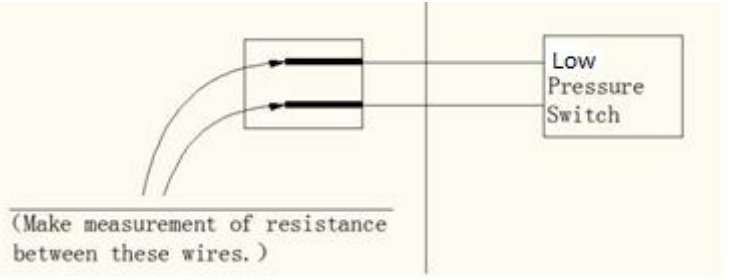

Replace the module board

Note: low probability, caution in handling

Note:
Normal high pressure switch opens below 14.5PSIG, resets above 31.9PSIG.

CHECK 10

6.10 Check for Discharge Temperature Switch (DTS)

Discharge Temperature Switch :
Whether the switch can start normally when start the machine

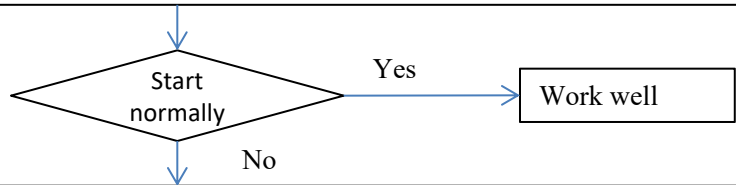

When power off and pull up

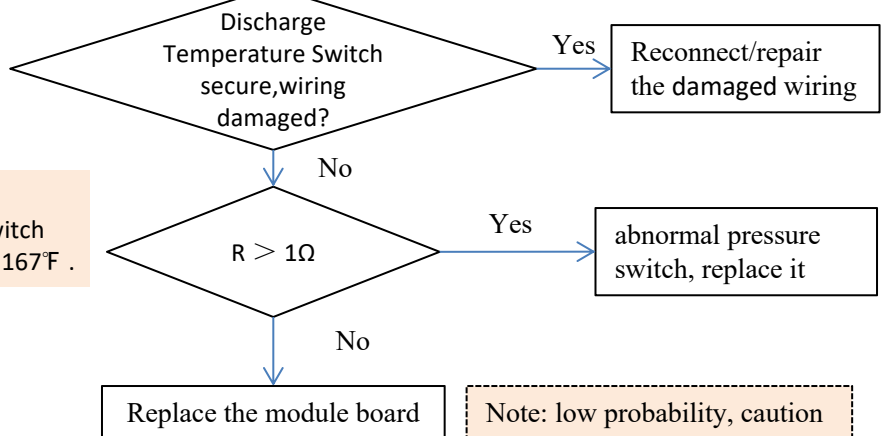
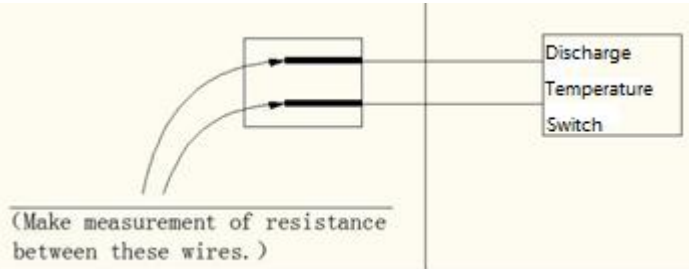

Note:
Normal discharge temperature switch opens above 239°F , resets below 167°F .

Note: low probability, caution in handling

CHECK 11

6.11 Check for Outdoor fan motor

Outdoor fan motor:
Whether fan can start normally

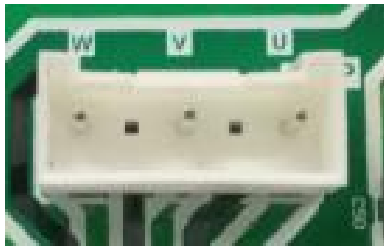

Resistance (Ω)	100W/200W
Between U and V	<36
Between V and W	<36
Between W and U	<36
Between U/V/W and ground	>10M

If the current is pulsating violently or abnormally beyond the "B" value

Motor output (W)	B(A)
200	<2.2

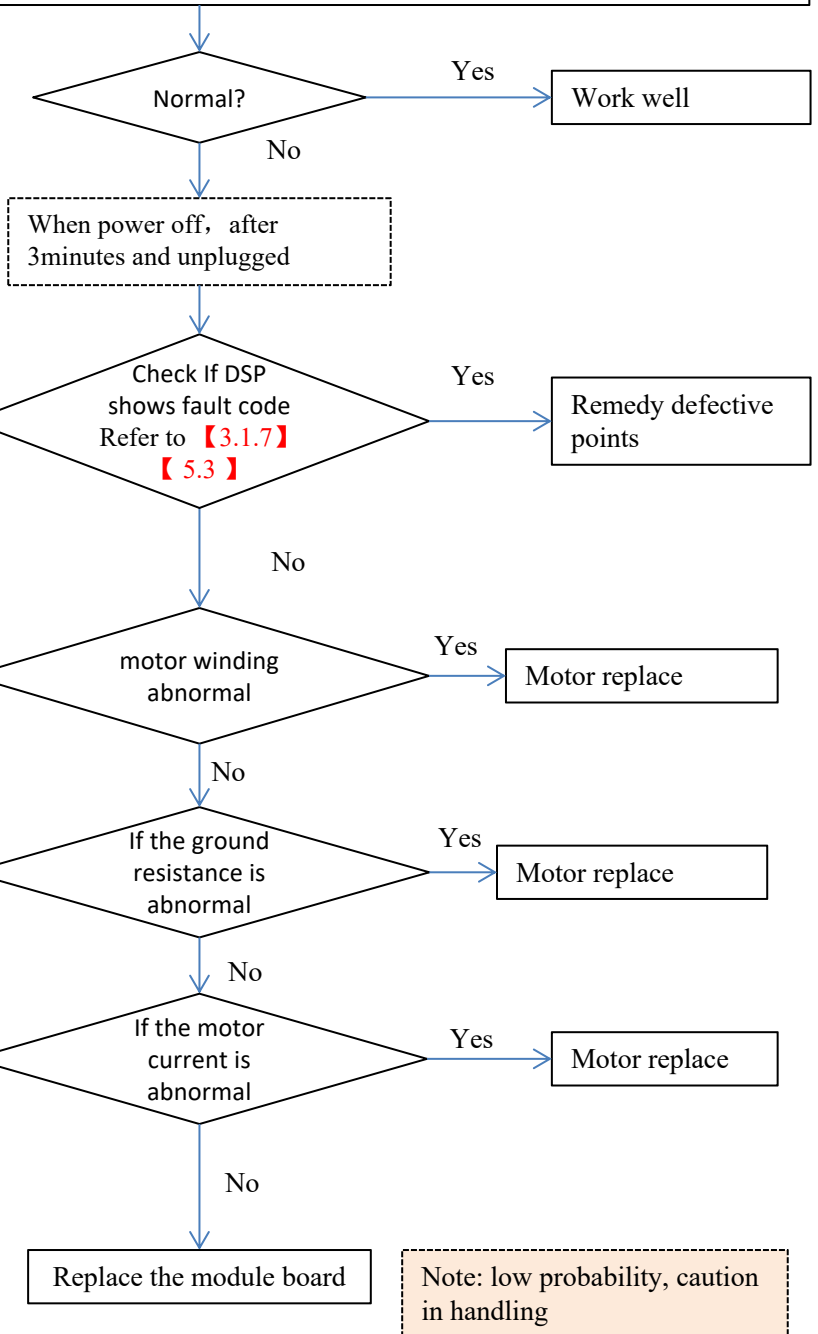

CHECK 12

6.12 Check for Compressor

Compressor:
Whether compressor can start normally

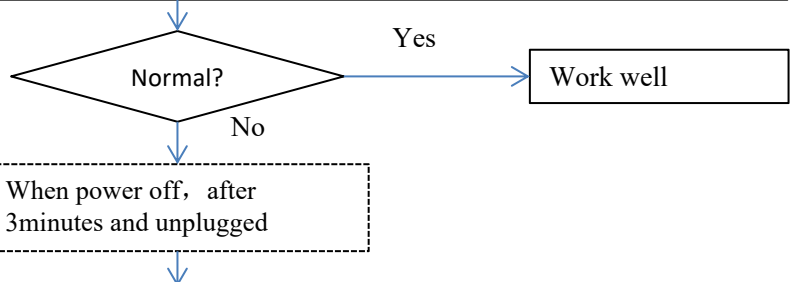

For Scroll compressor, supply wiring is unitary, you can check it with colour (Red for L1, Black for L2, White for S)

Resistance (Ω)	Rotary	Scroll
Between R and C (L1 and L2)	<2	<2
Between C and S (L1 and S)	<2	<1
Between R and S (L2 and S)	<4	<1
Between U/V/W and ground	>10M	>10M

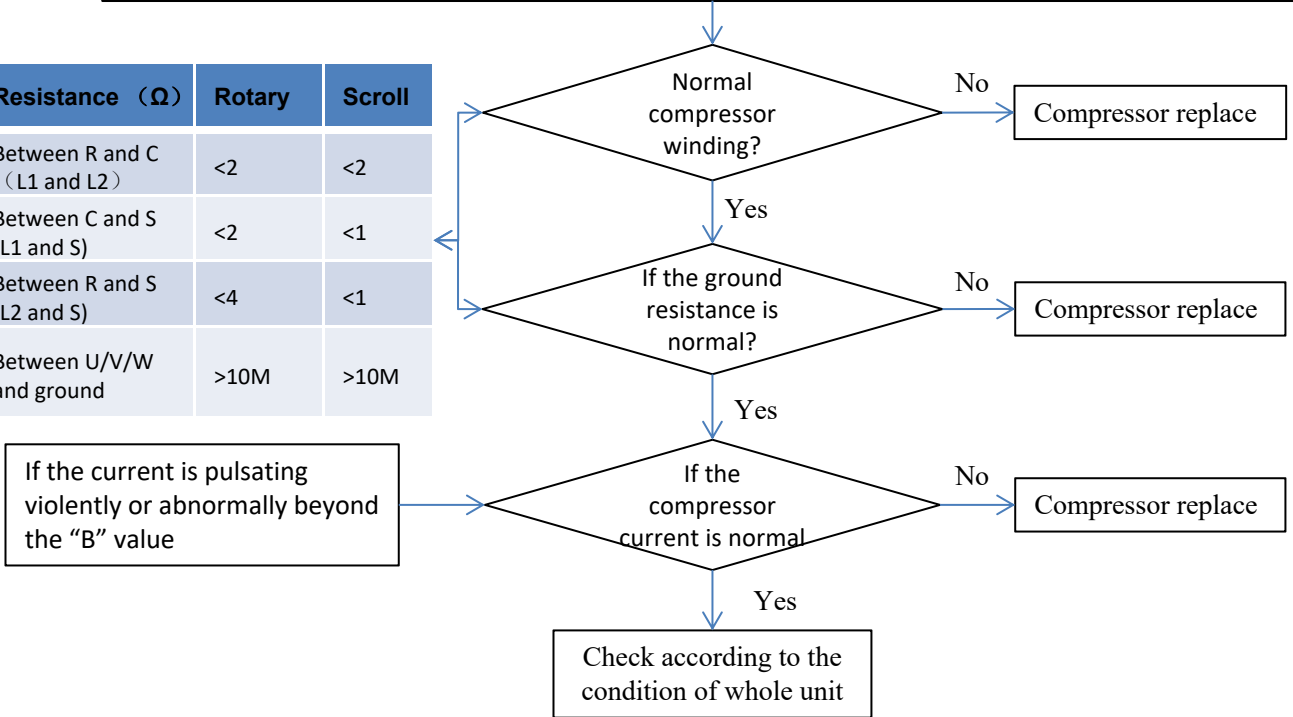

Model	2Ton	2.5Ton	3Ton	3.5Ton	4Ton	5Ton
B(A)	12	16	18	20	24	32

CHECK 13

6.13 Check for PSC indoor fan motor status

Indoor air flow is normal/Check the capacity by $BTU = \Delta T * CFM * 1.5$ in force mode

If It is normal
Yes → Work normally

If there is blockage of the indoor duct
Yes → Clean the blockage

Check if there is 187-253V power supply
No → Correct the power supply

Check if there is 18-28Vac between Transformer output
No → Replace the transformer

If LED light flash
Yes → Refer to **【 3.1.9/5.4 】**

If there is 18-28Vac between R&C terminal
No → Replace the control board

If there is 18-28Vac between G&C terminal
No → Check if the thermostat not calling or replace the thermostat

If there is 187-253Vac between N & FAN speed
No → Replace the control board

Yes → Replace the motor

Measure the power supply (L1&L2, red and black wire)



Red and Black wire of signal

Green and Black wire of signal

Fan speed according to the following chart

SW6-1/2	ON	OFF	1	2	Fan Speed
			Green	White	L
			White	Green	L
			Green	Green	M
			White	Green	H

CHECK 14

6.14 Check for ECM indoor fan motor status

Indoor air flow is normal/Check the capacity by $BTU = \Delta T * CFM * 1.5$ in force mode

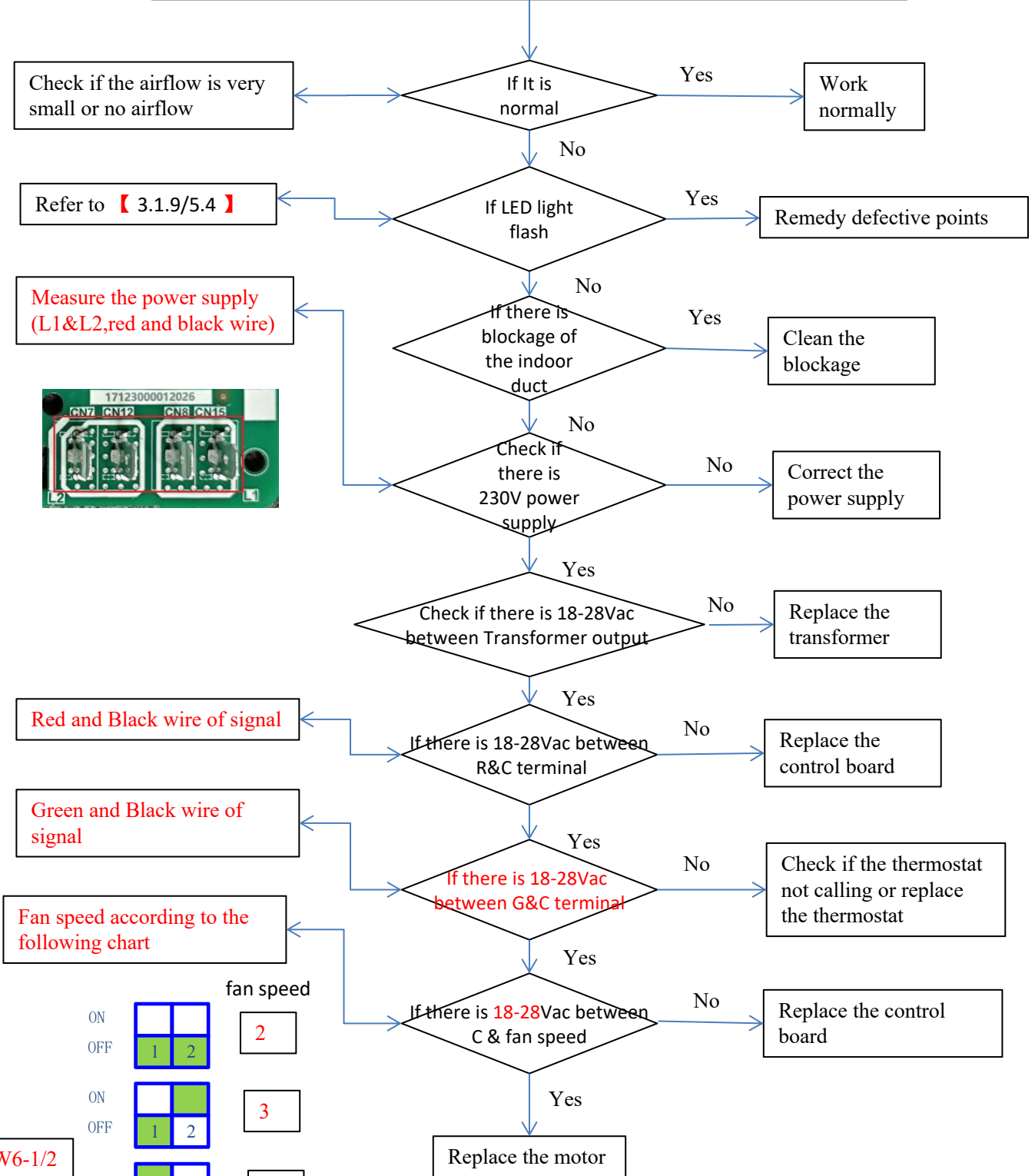

Check if the airflow is very small or no airflow

Refer to **【 3.1.9/5.4 】**

Measure the power supply (L1&L2,red and black wire)



Red and Black wire of signal

Green and Black wire of signal

Fan speed according to the following chart

		fan speed		
ON				2
OFF		1	2	
ON				3
OFF		1	2	
ON				4
OFF		1	2	
ON				5
OFF		1	2	

SW6-1/2

CHECK 15

6.15 Check for Outdoor fan motor Speed

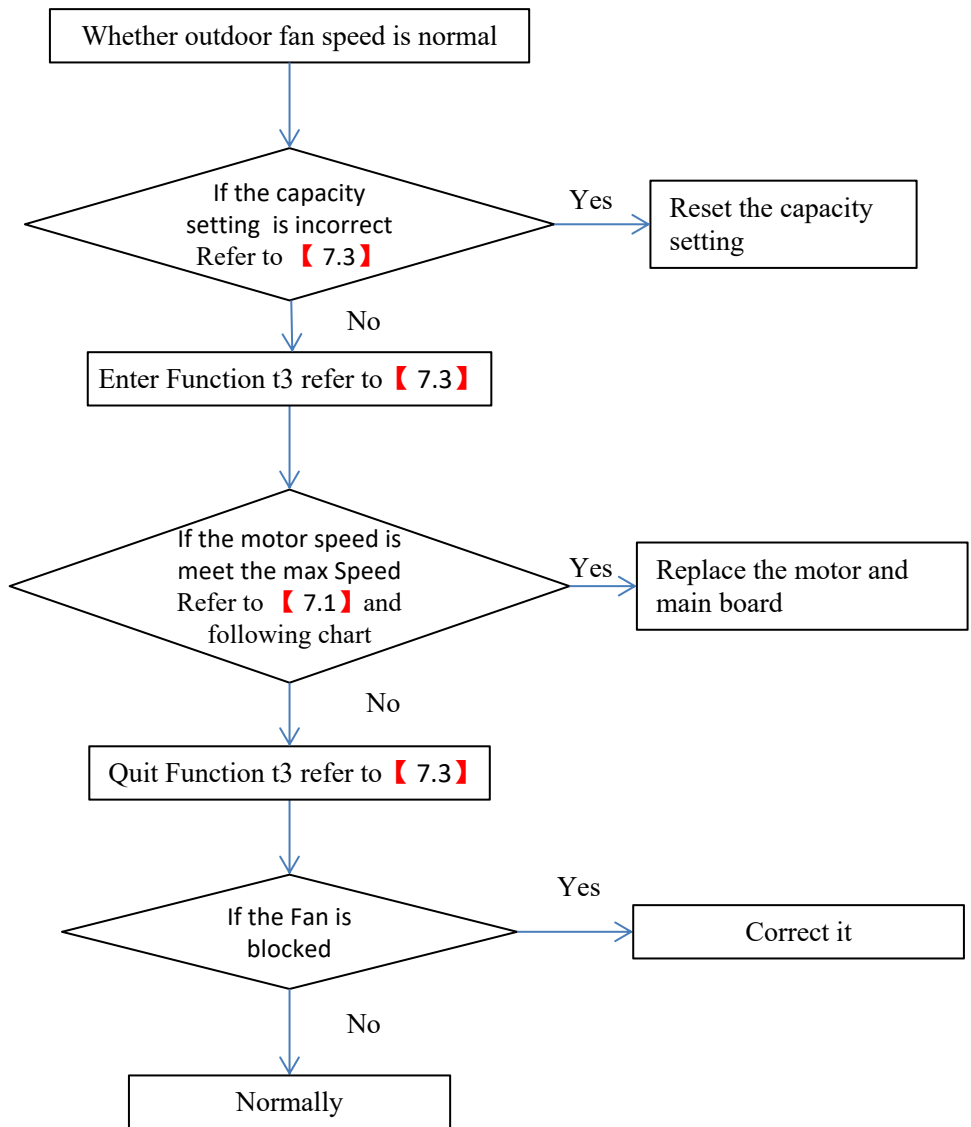

CAPACITY SETTING	MODEL	24 kBtu/h 2 TON	30 kBtu/h 2.5 TON	36 kBtu/h 3 TON
	13.4 HP	001,1	010,1	010,1
		42 kBtu/h 3.5 TON	48 kBtu/h 4 TON	60 kBtu/h 5 TON
		100,1	100,1	100,1

Capacity setting	0010	0101	1001
Max Speed	850	930	1050

CHECK 16

6.16 Check for FUSE

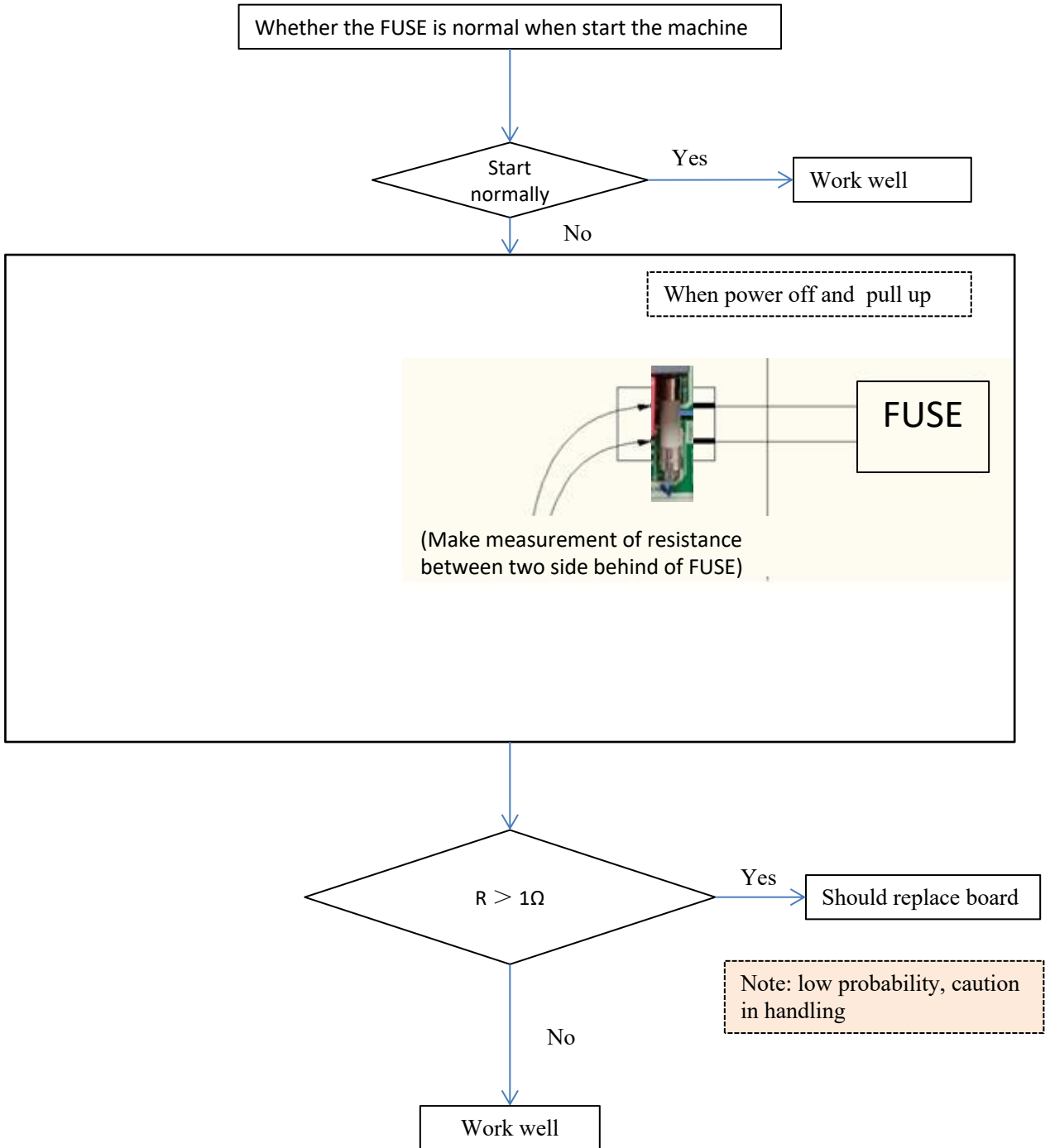

PART 7 Appendix	77
7.1 Wiring Diagrams	78
7.2 Main board replacement procedure	81
7.3 Menu button Function	84
7.4 Troubleshooting Guide	85
7.5 Temperature and Resistance Relationship Tables	86
7.6 Refrigerant sensor repair and replacement guidelines separately .	87
7.7 Wind pressure switch maintenance and replacement	88

HP System Wiring Diagram (24/30/36K)

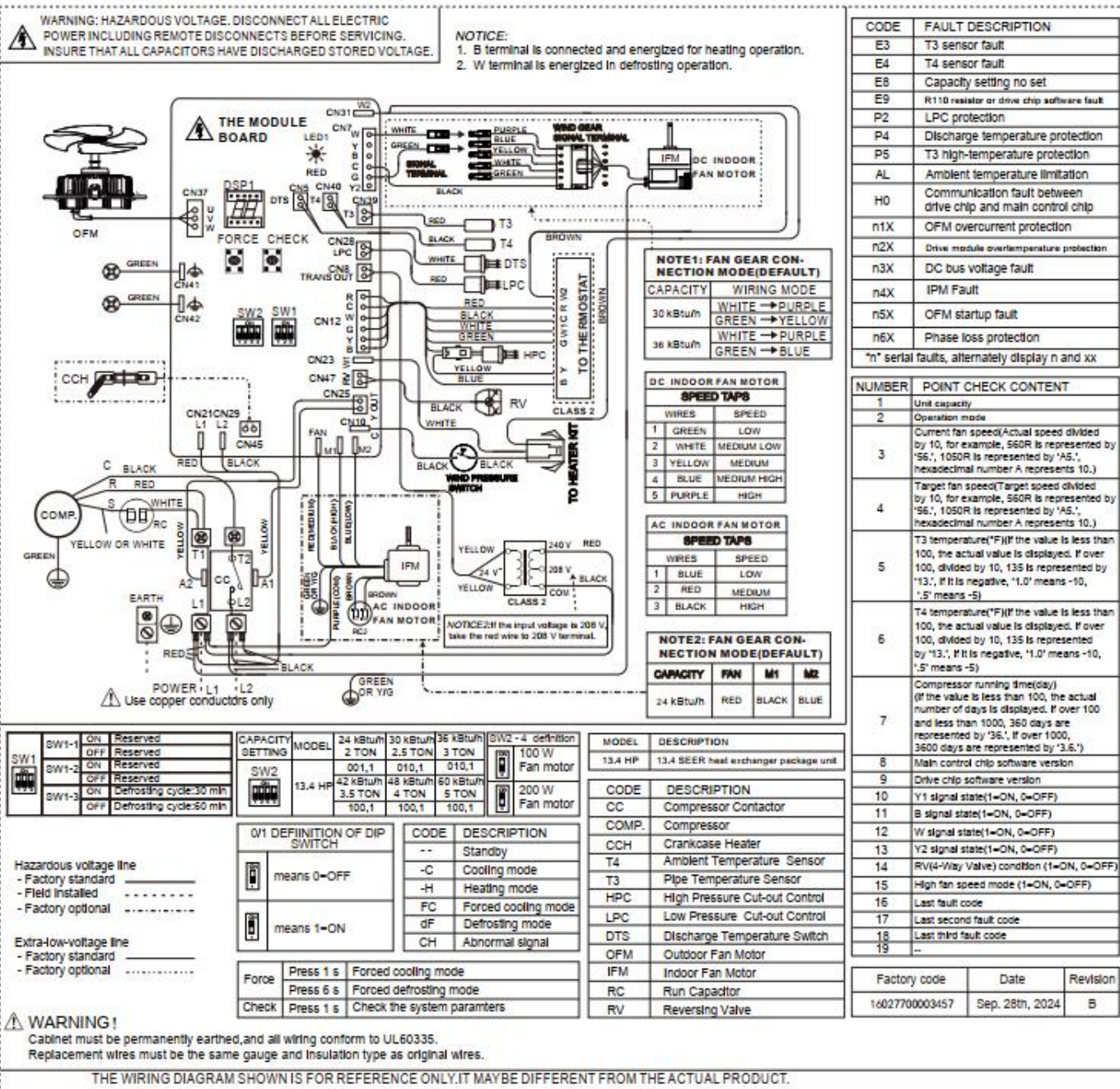

HP System Wiring Diagram (42/48K)

WARNING: HAZARDOUS VOLTAGE. DISCONNECT ALL ELECTRIC POWER INCLUDING REMOTE DISCONNECTS BEFORE SERVICING. INSURE THAT ALL CAPACITORS HAVE DISCHARGED STORED VOLTAGE.

FOR REFRIGERANT LEAK PROTECTION (LEAK ALARM DEVICE)

NOTICE 1:
1. B terminal is connected and energized for heating operation.
2. W terminal is energized in defrosting operation.

NOTICES:

- If connected to the 1-Stage controller, please short the signals Y1 and Y2.
- Connect R to R, G to G, Y to Y, etc. See outdoor instruction for details.
- If some signal lines of CN36 are not used, please wrap them up separately with CAP.

CAUTION:

- Use copper wire (75 C min.) only between disconnect switch and unit.
- To be wired in accordance with NEC and local codes.
- If any of the original wires, as supplied, must be replaced. Use the same or equivalent type wires.
- If the input voltage is 208 V, please change the transformer tap by taking the red wire to 208 V terminal.
- The rated output operating condition of CN 34 is 24 V AC/1A or 30 V DC/1A or 250 V AC/1A. Please refer to the manual for wiring methods.

WARNING!
Cabinet must be permanently earthed, and all wiring conform to UL60335. Replacement wires must be the same gauge and insulation type as original wires.

CODE	DESCRIPTION	CODE	DESCRIPTION
--	Standby	CC	Compressor Contactor
-C	Cooling mode	COMP.	Compressor
-H	Heating mode	CCH	Crankcase Heater
FC	Forced cooling mode	T4	Ambient Temperature Sensor
dF	Defrosting mode	T3	Pipe Temperature Sensor
CH	Abnormal signal	HPC	High Pressure Cut-out Control
		LPC	Low Pressure Cut-out Control
		DTS	Discharge Temperature Switch
		OFM	Outdoor Fan Motor
		RC	Run Capacitor
		RV	Reversing Valve
		IFM	Indoor Fan Motor

Force	Press 1 s	Forced cooling mode
	Press 6 s	Forced defrosting mode
Check	Press 1 s	Check the system parameters

SETTING INSTRUCTIONS

DIP SWITCH	G	WW1/W2
SW6-1,2	L	H
	L	H
	M	H
	H	H
SW6-3	0 S OFF-DELAY	
	90S OFF-DELAY (FACTORY DEFAULT)	
SW6-4	NOT USED	
	FACTORY DEFAULT	

CAPACITY SETTING	MODEL	24 kBTU/h ± 10%	30 kBTU/h ± 10%	36 kBTU/h ± 10%
SW7	13.4 HP	001,1	010,1	010,1
		3.5 TON	4 TON	5 TON
		100,1	100,1	100,1

SW2 - 4 defritition	100 W Fan motor	200 W Fan motor
SW1-1	ON Reserved	
	OFF Reserved	
SW1-2	ON Reserved	
	OFF Reserved	
SW1-3	ON Defrosting cycle:30 min	
	OFF Defrosting cycle:60 min	

MODEL	DESCRIPTION
13.4 HP	13.4 SEER heat exchanger package unit

CODE	FAULT DESCRIPTION
E3	T3 sensor fault
E4	T4 sensor fault
E8	Capacity setting no set
E9	R110 resistor or drive chip software fault
P2	LPC protection
P4	Discharge temperature protection
P5	T3 high-temperature protection
AL	Ambient temperature limitation
H0	Communication fault between drive chip and main control chip
n1X	OFM overcurrent protection
n2X	Drive module overtemperature protection
n3X	DC bus voltage fault
n4X	IPM Fault
n5X	OFM startup fault
n6X	Phase loss protection

*"n" serial faults, alternately display n and xx

NUMBER	POINT CHECK CONTENT
1	Unit capacity
2	Operation mode
3	Current fan speed(Actual speed divided by 10, for example, 560R is represented by '56.', 1050R is represented by '105.', hexadecimal number A represents 10.)
4	Target fan speed(Target speed divided by 10, for example, 560R is represented by '56.', 1050R is represented by '105.', hexadecimal number A represents 10.)
5	T3 temperature(*F)(If the value is less than 100, the actual value is displayed. If over 100, divided by 10, 135 is represented by '13.'. If it is negative, '1.0' means -10, '1.5' means -5)
6	T4 temperature(*F)(If the value is less than 100, the actual value is displayed. If over 100, divided by 10, 135 is represented by '13.'. If it is negative, '1.0' means -10, '1.5' means -5)
7	Compressor running time(day)(If the value is less than 100, the actual number of days is displayed. If over 100 and less than 1000, 360 days are represented by '36.'. If over 1000, 3600 days are represented by '3.6'.)
8	Main control chip software version
9	Drive chip software version
10	Y1 signal state(1=ON, 0=OFF)
11	B signal state(1=ON, 0=OFF)
12	W signal state(1=ON, 0=OFF)
13	Y2 signal state(1=ON, 0=OFF)
14	RV(4-Way Valve) condition (1=ON, 0=OFF)
15	High fan speed mode (1=ON, 0=OFF)
16	Last fault code
17	Last second fault code
18	Last third fault code
19	--

Factory code	Date	Revision
1602770003456	Sep. 28th, 2024	B

THE WIRING DIAGRAM SHOWN IS FOR REFERENCE ONLY. IT MAYBE DIFFERENT FROM THE ACTUAL PRODUCT.

HP System Wiring Diagram (60K)

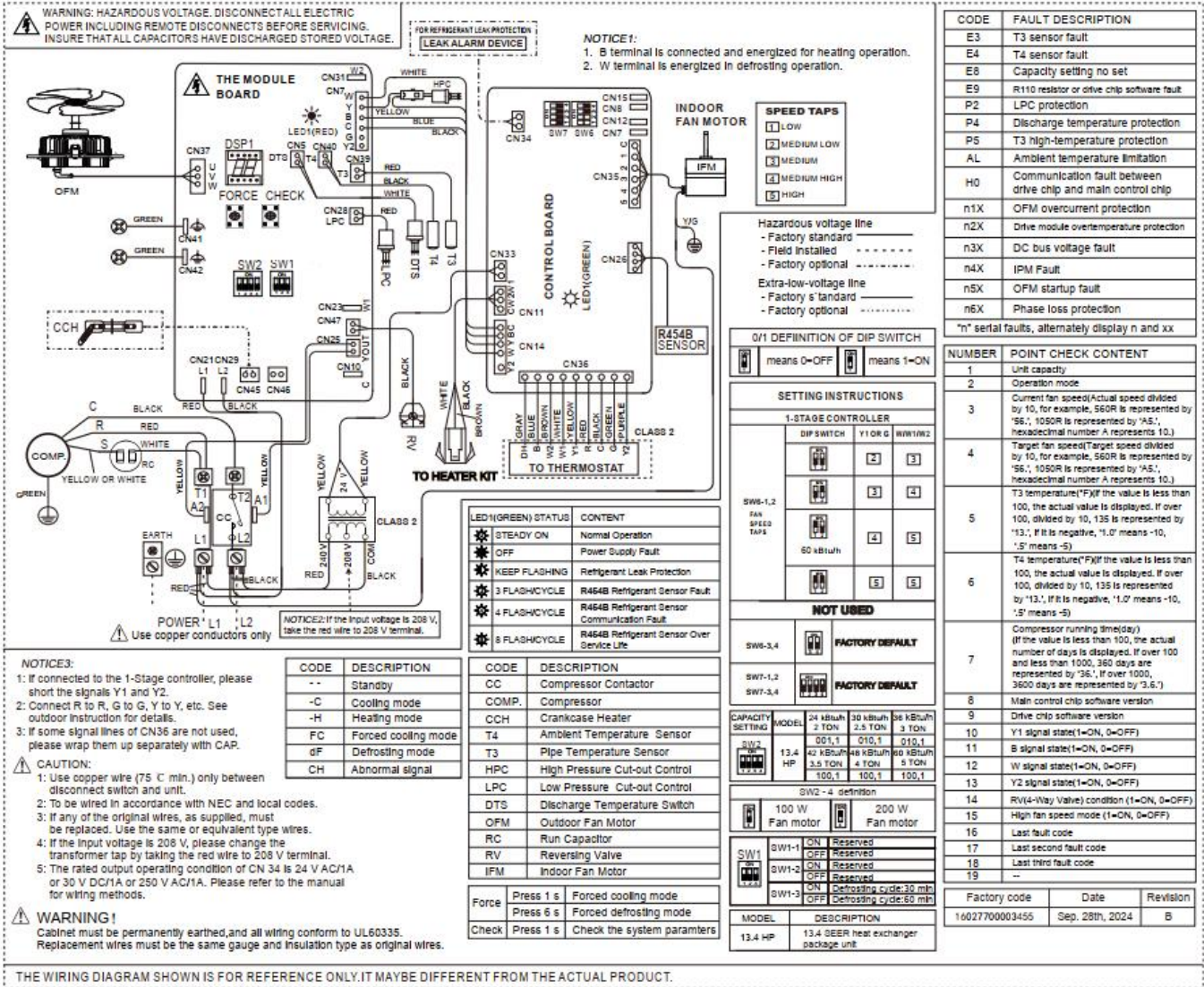

Appendix 2 7.2 Main board replacement procedure

**WARNING:**

- ▶ Improper servicing could result in dangerous operation, injury or property damage. The operations described below must be performed by qualified personnel.

**NOTICE:**

- ▶ Do not directly touch the components on the control board to avoid static electricity damage.

Board Replacement Procedure

1. Turn off power to the unit and wait AT LEAST 3 minutes before removing the outdoor unit's control board access panel.

**WARNING: ELECTRICAL HAZARD 325 VOLTS DC**

- ▶ Wait 3 minutes after disconnecting power, then verify DC voltage is less than 42.4 VDC at port CN44 (P-N). Components may store a dangerous electrical potential of 325 Volts DC. Failure to follow these instructions could result in personal injury or death.

**NOTICE:**

- ▶ Take a photo before removing any screws or wiring to use as reference when installing the new board.
- ▶ Use a screwdriver instead of an electric screwdriver/drill, otherwise the control board may be damaged.
- ▶ There is no need to disconnect the field supplied thermostat wires; directly remove the thermostat wire plug on the control board.

2. Remove all wires and plugs from the control board.
3. Remove the 6 screws on the control board and separate the board from the unit (Refer to Figure 1: items circled in yellow.)

**NOTICE:**

- ▶ Hold the control board before removing the last screw, otherwise the control board may be damaged because of falling.

**THE MODULE BOARD**

*The photo shown is for reference only, the actual product may vary.

Figure 1

Appendix 2 7.2 Main board replacement procedure



The control board for 60K



The control board for 42K,48K

*The photo shown is for reference only, the actual product may vary.

4. Install the 6 pairs separation pillars removed from the old control board on the new control board (Refer to Figure 2: items circled in red.)



SEPARATION PILLAR

*The photo shown is for reference only, the actual product may vary.

Figure 2

5. Install the new board on the unit and fasten all screws removed from the old board (Refer to Figure 1 for screw location.)

6. Reconnect the wires according to the wiring diagram (Or refer to the photo before disassembly.)
(Note: CN34, CN35, CN38, CN44 do not have any wire connections.)
7. Set and check SW2 switch code. Refer to Table 1 or the wiring diagram for information (Refer to Figure 3: SW2 circled in blue.)

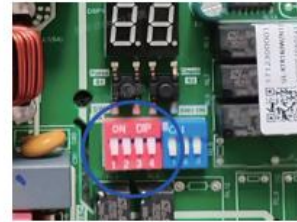

SW2 SWITCH

Figure 3

SW2 - 4 definition			
	100 W Fan motor		200 W Fan motor

CAPACITY SETTING	MODEL	24 kbtu/h 2 TON	30 kbtu/h 2.5 TON	36 kbtu/h 3 TON
	13.4 HP	001,1	010,1	010,1
		42 kbtu/h 3.5 TON	48 kbtu/h 4 TON	60 kbtu/h 5 TON
		100,1	100,1	100,1

8. SW1 switch is set for the defrost control mode.

	SW1-1	ON	13.4HP package (only used for replacing board)
		OFF	Reserved
	SW1-2	ON	Reserved
		OFF	Reserved
	SW1-3	ON	Defrosting cycle:30 min
		OFF	Defrosting cycle:60 min

9. Double check all wire connections and screw positions before powering on.

Appendix 2 7.2 Main board replacement procedure

10. If the machine is 42K, 48K or 60K ,Carefully remove the control board from the support (note to use both hands when disassembling)

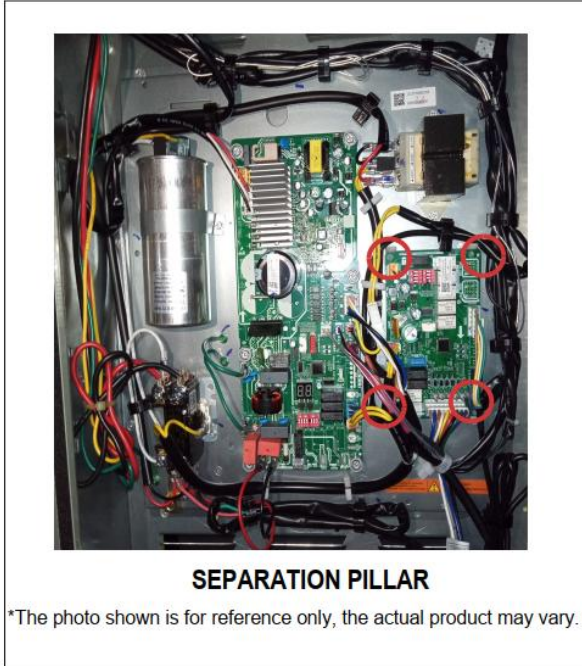

Figure 5

11. Install the new board on the unit removed from the old board (Refer to Figure 1 for screw location.)
12. Reconnect the wires according to the wiring diagram (Or refer to the photo before disassembly.)
13. Set and check SW6 switch code. Refer to Table 1 or the wiring diagram for information (Refer to Figure 6, SW6 and circled in red or blue.)

SETTING INSTRUCTIONS		
DIP SWITCH	0	1
DW6-1,2	L	H
FAN SPEED TAP	L	H
	M	H
	H	H
SW6-3	0 S OFF-DELAY	
	90S OFF-DELAY (FACTORY DEFAULT)	
NOT USED		
SW6-4	FACTORY DEFAULT	

SETTING INSTRUCTIONS		
DIP SWITCH	0	1
DW6-1,2	L	H
FAN SPEED TAP	L	H
	M	H
	H	H
SW6-3	0 S OFF-DELAY	
	90S OFF-DELAY (FACTORY DEFAULT)	
NOT USED		
SW6-4	FACTORY DEFAULT	

SW6 SWITCHE

14. Double check all wire connections and screw positions before powering on.

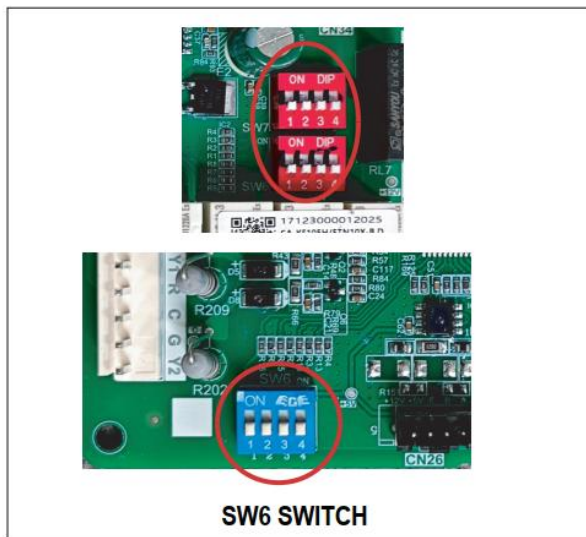
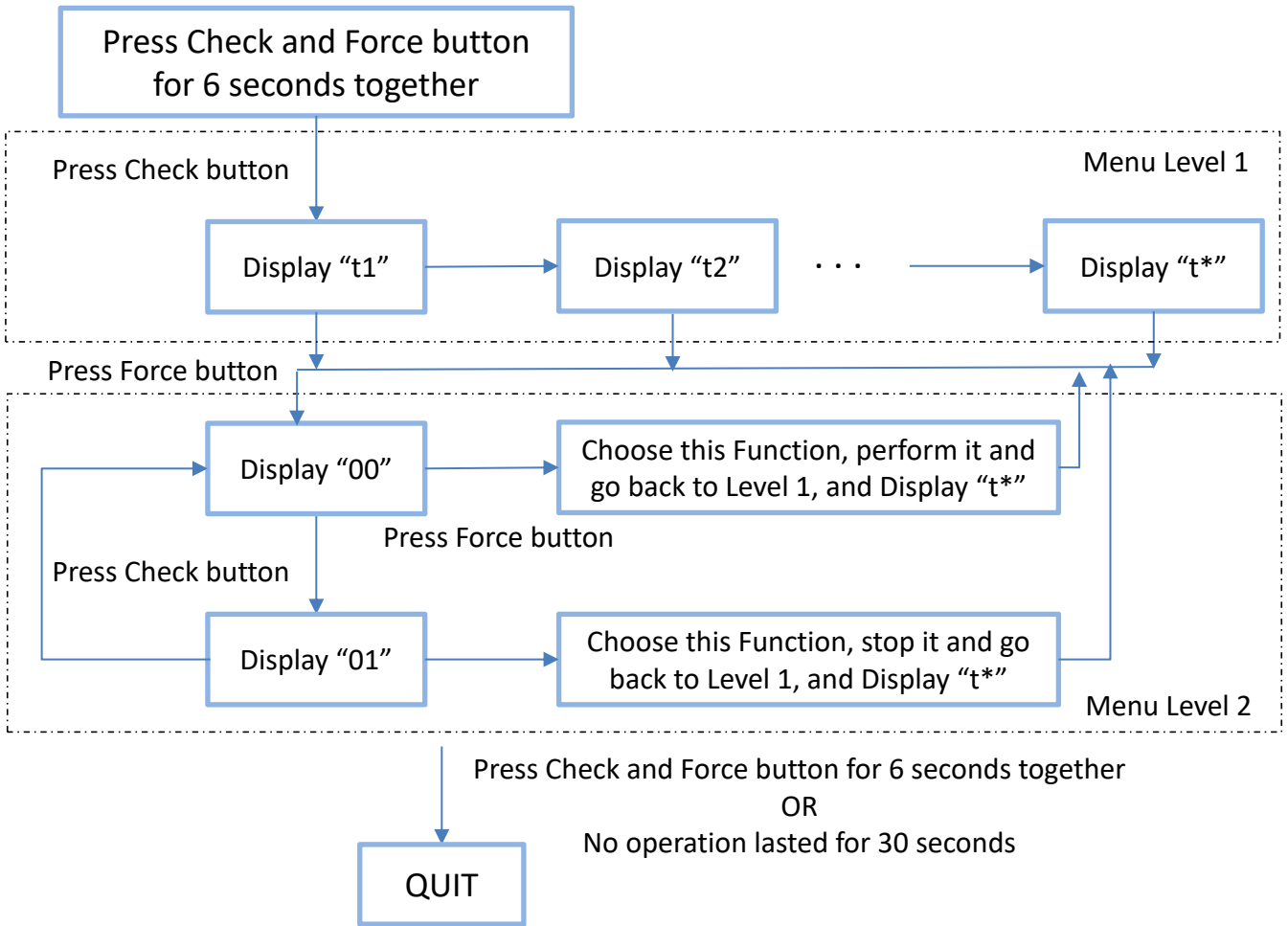

Figure 6

Appendix 3 7.3 Menu button Function



Display	Function Mode	Choose "00"	Choose "01"
t1	Motor self-test	Disable	Enable
t2	Compressor self-test	Disable	Enable
t3	Permanent full-speed of motor	Disable	Enable
t4	Clean history fault code	Quit	Enter
t5	Clean Compressor total operation time	Quit	Enter
t6	Reserved	Quit	Enter

Temperature °F	Resistance kΩ	Temperature °F	Resistance kΩ	Temperature °F	Resistance kΩ	Temperature °F	Resistance kΩ
-4	106.73	37	29.87	78	10	119	3.69
-3	103.25	38	29.22	79	9.5	120	3.61
-2	99.89	39	28.19	80	9.26	121	3.53
-1	96.65	40	27.39	81	9.03	122	3.45
0	93.53	41	26.81	82	8.81	123	3.38
1	90.53	42	25.85	83	8.59	124	3.3
2	87.62	43	25.12	84	8.38	125	3.23
3	84.83	44	24.42	85	8.17	126	3.16
4	82.13	45	23.73	86	7.97	127	3.1
5	79.52	46	23.07	87	7.78	128	3.03
6	77.01	47	22.42	88	7.59	129	2.96
7	74.58	48	21.8	89	7.4	130	2.9
8	72.24	49	21.2	90	7.22	131	2.84
9	69.98	50	20.61	91	7.05	132	2.78
10	67.8	51	20.04	92	6.88	133	2.72
11	65.69	52	19.49	93	6.72	134	2.67
12	63.65	53	18.96	94	6.56	135	2.61
13	61.68	54	18.44	95	6.4	136	2.56
14	59.78	55	17.94	96	6.25	137	2.5
15	57.95	56	17.45	97	6.1	138	2.45
16	56.17	57	16.98	98	5.96	139	2.4
17	54.46	58	16.52	99	5.82	140	2.35
18	52.8	59	16.08	100	5.68	141	2.3
19	51.2	60	15.65	101	5.55	142	2.25
20	49.65	61	15.23	102	5.42	143	2.21
21	48.16	62	14.83	103	5.3	144	2.16
22	46.71	63	14.43	104	5.18	145	2.12
23	45.31	64	14.05	105	5.06	146	2.08
24	43.95	65	13.68	106	4.94	147	2.03
25	42.64	66	13.32	107	4.83	148	1.99
26	41.38	67	12.97	108	4.72	149	1.95
27	40.15	68	12.64	109	4.61	150	1.91
28	38.97	69	12.31	110	4.51	151	1.88
29	37.82	70	11.99	111	4.41	152	1.84
30	36.71	71	11.68	112	4.31	153	1.8
31	35.64	72	11.38	113	4.21	154	1.77
32	34.6	73	11.09	114	4.12	155	1.73
33	33.59	74	10.8	115	4.03	156	1.7
34	32.61	75	10.53	116	3.94	157	1.66
35	31.67	76	10	117	3.85	158	1.63
36	30.76	77	10	118	3.77	159	1.6

- 1、 Before repairing and replacing refrigerant sensor, it is necessary to unplug the terminals(①) located at the electronic control board and cut off the zip ties at specific positions.
- 2、 Remove the screws(②) that fix the Refrigerant sensor and replace the Refrigerant sensor.
- 3、 Reuse screw to secure the Refrigerant sensor.
- 4、 Use zip ties to reattach the sensor wire body to the side of the Refrigerant sensor and the wire buckle.

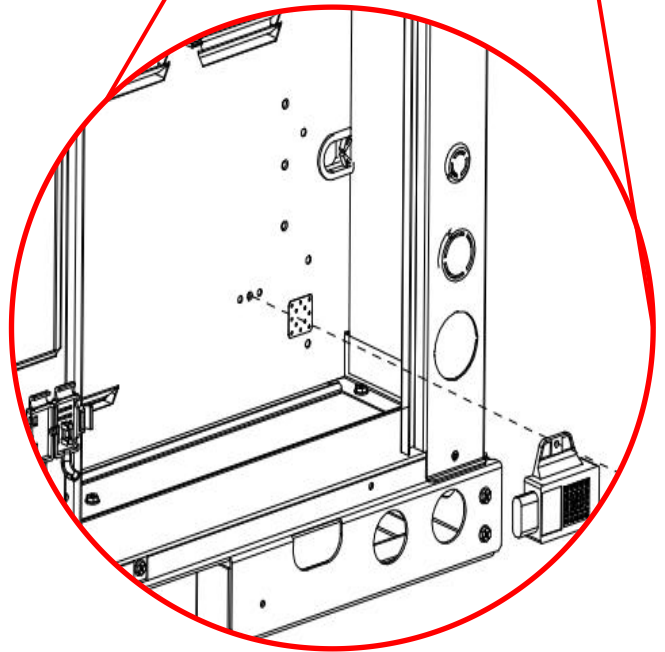
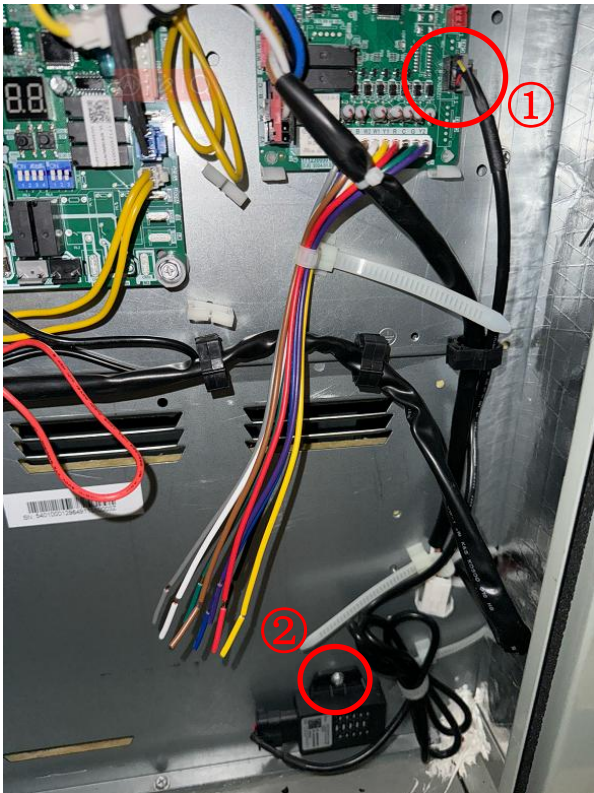
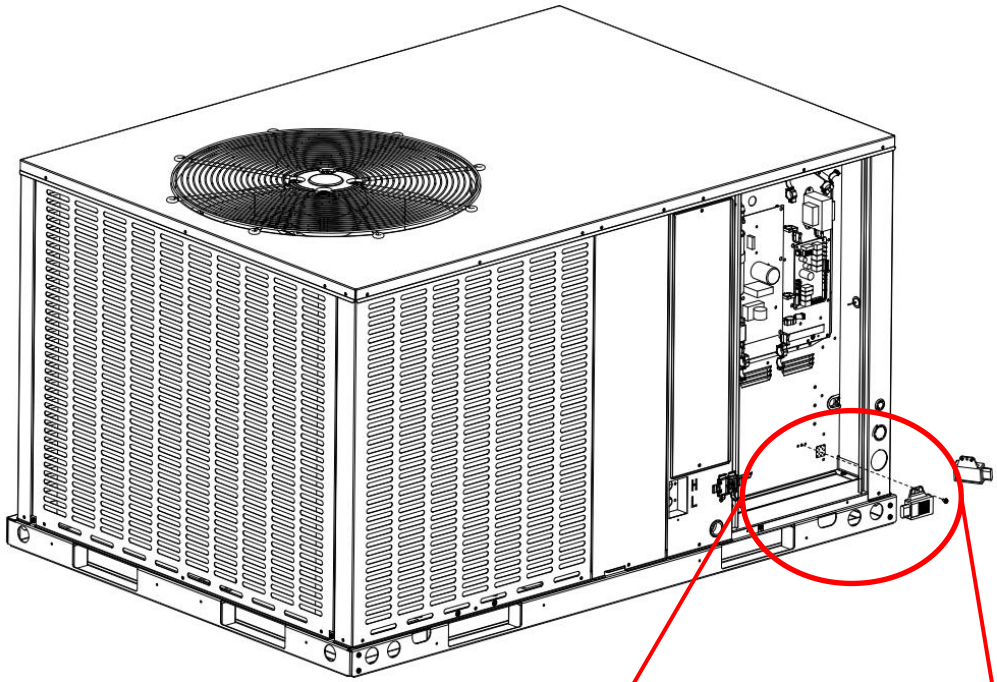

NOTE : The photo shown is for reference only,
the actual product may vary

- 1、 Remove the control wires(①) and the silicone tube(②),and then Remove the screws(③) on the back.
- 2、 Replace the wind pressure Switch and mounting screw.
- 3、 Mounting the silicone tube and the control wire.

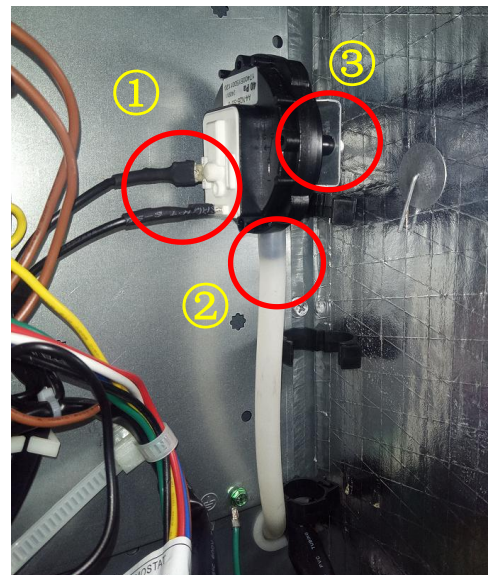
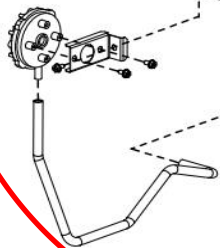
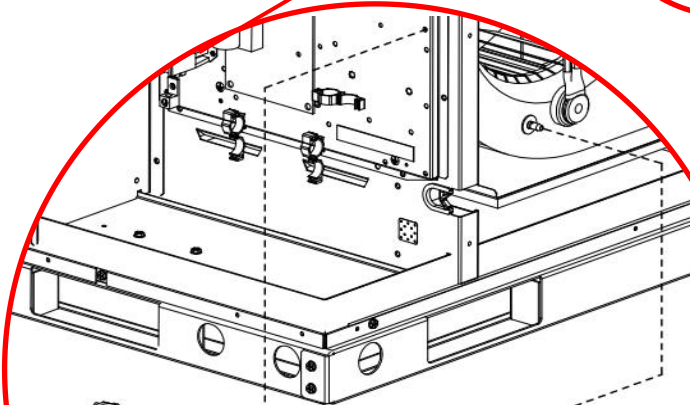
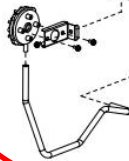
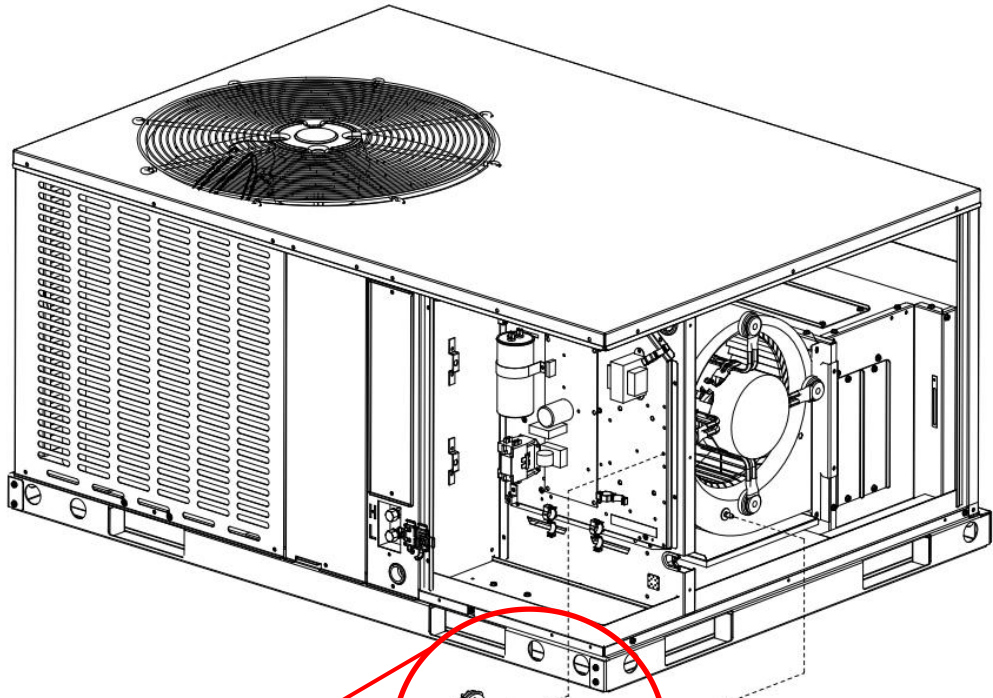

NOTE : The photo shown is for reference only, the actual product may vary