

ComfortStar®

Air Conditioning & Heating Products

INSTALLATION AND OPERATION MANUAL

PACKAGE HEAT PUMP
13.4 SEER2 SERIES - (2 Ton-5 Ton)
FEATURING R454B
CDP7 Series



Original instructions.
Please read this manual carefully and keep it for future reference.
All the pictures in this manual are for illustrations purpose only.





RECOGNIZE THIS SYMBOL AS AN INDICATION OF IMPORTANT SAFETY INFORMATION

⚠ WARNING

These instructions are intended as an aid to qualified, licensed service personnel for proper installation, adjustment and operation of this unit. Read these instructions thoroughly before attempting installation or operation. Failure to follow these instructions may result in improper installation, adjustment, service or maintenance possibly resulting in fire, electrical shock, property damage, personal injury or death.

CONTENTS

1 SAFETY

- 1.1 Safety Signs 01
- 1.2 Safety Precautions 02

2 INSTALLATION

- 2.1 Pre-Installation 08
- 2.2 Clearance 08
- 2.3 Rigging and Handling 08
- 2.4 Unit Dimensions 09
- 2.5 Roof Curb 14
- 2.6 Location Restrictions 15
- 2.7 Refrigerant Charge and Room Area Limitations 16
- 2.8 R454B Refrigerant Sensor 18

3 AIRFLOW PERFORMANCE

- 3.1 Airflow Performance Data 20

4 DUCTWORK 22

5 CONDENSATE DRAIN CONNECTION

- 5.1 Install Drain Pipe 23
- 5.2 Removal and Cleaning the Drain Pan 23

6 ABOUT THE AIR FILTER

- 6.1 Air Filter (Not Factory-Installed) 23

7 ELECTRICAL - LOW VOLTAGE

- 7.1 Low voltage wires maximum length 25
- 7.2 Low voltage wires connections 25

8 ELETRICAL – HIGH VOLTAGE

- 8.1 High Voltage Power Supply 28
- 8.2 High Voltage Wires Sizes, Disconnect Switch and Breaker 28
- 8.3 High Voltage Wires Connections 29

9 ELECTRIC HEATER KIT

- 9.1 Electric Heater Kit Breaker Information..... 30
- 9.2 Electric Heater Kit Install Information 30
- 9.3 Electric Heater Kit Electrical Data..... 31

10 SETTING

- 10.1 Setting the Indoor Unit..... 32
- 10.2 Setting the Outdoor Unit..... 32

11 START UP

- 11.1 System Start Up..... 33
- 11.2 External Static Pressure Setup..... 33

12 SYSTEM OPERATION

- 12.1 Compressor Crankcase Heater(Optional)..... 34
- 12.2 Reversing Valve Operation..... 34
- 12.3 Protection..... 34
- 12.4 Defrost Mode* (For HP System Only)..... 34
- 12.5 Thermostat Signals..... 35

13 SERVICE AND MAINTENANCE

- 13.1 Error Code and Troubleshooting..... 36
- 13.2 Illustration for Covering Side Openings for Downflow Application 37
- 13.3 Care and Maintenance 38

14 DISPOSAL..... 39

This document is customer property and is to remain with this unit.

These instructions do not cover all the different variations of systems nor does it provide for every possible contingency to be met in connection with installation.

All phases of this installation must comply with NATIONAL, STATE and LOCAL CODES. If additional information is required please contact your local distributor.

1 SAFETY

1.1 Safety Signs

DANGER

indicates a hazardous situation which, if not avoided, will result in death or serious injury

WARNING

indicates a hazardous situation which, if not avoided, could result in death or serious injury





CAUTION

indicates a hazardous situation which, if not avoided, could result in minor or moderate injury

NOTICE

is used to address practices not related to physical injury

Explanation of symbols displayed on the unit

	DANGER	This symbol shows that this appliance uses a mild flammable refrigerant. If the refrigerant is leaked and exposed to an external ignition source, there is a risk of fire.
	WARNING	This symbol shows that the appliance shall be installed, operated and stored in a room with a floor area not less than the minimum room area.
	CAUTION	This symbol shows that the operation manual should be read carefully.
	CAUTION	This symbol shows that a service personnel should be handling this equipment with reference to the installation manual.
	CAUTION	This symbol shows that information is available such as the operating manual or installation manual.

1.2 Safety Precautions

Please read before proceeding

⚠ WARNING

The manufacturer's warranty does not cover any damage or defect to the heat pump caused by the attachment or use of any components, accessories or devices (other than those authorized by the manufacturer) into, onto or in conjunction with the heat pump. You should be aware that the use of unauthorized components, accessories or devices may adversely affect the operation of the heat pump and may also endanger life and property. The manufacturer disclaims any responsibility for such loss or injury resulting from the use of such unauthorized components, accessories or devices.

⚠ DANGER

Disconnect all power to the unit before starting maintenance. Failure to do so can result in severe electrical shock or death.

WAIT FIVE (5) MINUTES after disconnecting power prior to touching electrical components as they may hold a dangerous charge of 380 VDC, then verify DC Voltage is less than 42VDC at inverter TEST POINTS P-N.

NOTICE

- This document is customer property and is to remain with this unit. Please return to service information pack upon completion of work.
- These instructions do not cover all variations in systems or provide for every possible contingency to be met in connection with the installation.
- Should further information be desired or should particular problems arise which are not covered sufficiently for the purchaser's purposes, the matter should be referred to your installing dealer or local distributor.

⚠ WARNING

Do not, under any circumstances, connect return ductwork to any other heat producing device such as a fireplace insert, stove, etc. Unauthorized use of such devices may result in fire, carbon monoxide poisoning, explosion, property damage, severe personal injury or death.

⚠ WARNING

The unit must be permanently grounded. A grounding lug is provided. Failure to ground this unit can result in fire or electrical shock causing property damage, severe personal injury or death.

⚠ WARNING

Only electric heater kits supplied by this manufacturer as described in this publication have been designed, tested, and evaluated by a nationally recognized safety testing agency for use with this unit. Use of any other manufactured electric heaters installed within this unit may cause hazardous conditions resulting in property damage, fire, body injury or death.

⚠ WARNING

This information is intended for use by individuals possessing adequate backgrounds of electrical and mechanical experience. Any attempt to repair air conditioning product may result in personal injury and/or property damage.

⚠ WARNING

HOT SURFACE

May cause minor to severe burning. Failure to follow this Caution could result in property damage or personal injury.
Do not touch the high-temperature components such as compressor .

⚠ WARNING

REFRIGERANT OIL

These units use R454B refrigerant. Use only R454B approved service equipment. These units use a POE oil (VG74 or equivalent)that readily absorbs moisture from the atmosphere. To limit this 'hygroscopic' action, the system should remain sealed whenever possible. If a system has been open to the atmosphere for more than 4 hours, the compressor oil must be replaced. Never break a vacuum with air and always change the driers when opening the system for component replacement.

⚠ CAUTION

CONTAINS REFRIGERANT

Failure to follow proper procedures can result in personal illness or injury or severe equipment damage. System contains oil and refrigerant under high pressure. Recover refrigerant to relieve pressure before opening system.

Flammable refrigerant used.

⚠ WARNING

This product can expose you to chemicals including Lead and Lead components, which are known to the State of California to cause cancer and birth defects or other reproductive harm. For more information go to www.P65Warnings.ca.gov.

⚠ CAUTION

EARTHING REQUIRED

Failure to inspect or use proper service tools may result in equipment damage or personal injury. All parts of this product that are capable of conducting electrical current are earthed. If earthing wires, screws, straps, clips, nuts, or washers used to complete a path to earth are removed for service, they must be returned to their original position and properly fastened.

⚠ WARNING

BRAZING REQUIRED

Failure to inspect lines or use proper service tools may result in equipment damage or personal injury. If using existing refrigerant lines make certain that all joints are brazed, not soldered.

If refrigerant gas leaks during installation, ventilate the area immediately.

Comply with national gas regulations.

⚠ WARNING

HIGH CURRENT LEAKAGE

Earthing is required before connecting electrical supply.

Failure to follow this warning could result in property damage, severe personal injury, or death.

⚠ WARNING

RISK OF FIRE

Mild flammable refrigerant used.

Follow handling instructions carefully in compliance with national regulations.

⚠ DANGER

FIRE, EXPLOSION

Store in a well ventilated room without continuously operating flames or other potential ignition.

⚠ WARNING

Do not use means to accelerate the defrosting process or to clean, other than those recommended by the manufacturer.

The appliance shall be stored in a room that does not have continuously operating ignition sources (for example: open flames, an operating gas appliance or an operating electric heater).

Do not pierce or burn the unit.

Be aware that refrigerants may not contain an odour.

⚠ WARNING

This appliance is not intended for use by persons (including children) with reduced physical, sensory or mental capabilities, or persons who lack experience and knowledge, unless they are supervised or have been given instructions concerning the use of the appliance by a person responsible for their safety.

Children should be supervised to ensure that they do not play with the appliance.

Any person who is involved with working on or opening a refrigerant circuit should hold a current valid certificate from an industry-accredited assessment authority, which authorizes their competence to handle refrigerants safely in accordance with an industry recognized assessment credential.

Servicing shall only be performed as recommended by the equipment manufacturer.

Maintenance and repair requiring the assistance of other skilled personnel shall be carried out under the supervision of a person competent in the use of flammable refrigerants.

Prior to beginning work on systems containing flammable refrigerants, safety checks are necessary to minimize the risk of ignition.

⚠ WARNING

When repairing the refrigerating system, comply with the following precautions prior to conducting work on the system:

- shall be undertaken according to controlled procedures so as to minimize the risk of the presence of flammable gases or vapors while the work is being performed.

- All maintenance staff and others working in the local area shall be instructed on the nature of work being carried out. Work in confined spaces shall be avoided.

- The area shall be checked with an appropriate refrigerant detector prior to and during work, to ensure the technician is aware of potentially toxic or flammable environment.

Ensure that the leak detection equipment being used is suitable for use with all applicable refrigerants, i.e. non-sparking, adequately sealed or intrinsically safe.

- If any hot work is to be conducted on the refrigerating equipment or any associated parts, appropriate fire extinguishing equipment shall be available and easily accessible. Have a dry powder or CO₂ fire extinguisher adjacent to the charging area.

- When carrying out work in relation to a refrigerating system that involves exposing any pipe work, no sources of ignition shall be used in such a manner that it may lead to the risk of fire or explosion.

All possible ignition sources, including cigarette smoking, should be kept sufficiently far away from the site of installation, repair, or removal and disposal of the unit, during which refrigerant can possibly be released into the surrounding space. Prior to beginning work, the area around the equipment is to be surveyed to make sure that there are no flammable hazards or ignition risks. "No Smoking" signs shall be clearly displayed.

Ensure that the area is in the open or that it is adequately ventilated before opening the system or conducting any hot work. A degree of ventilation shall continue during the period that the work is carried out. The ventilation should safely disperse any released refrigerant and preferably expel it externally into the surroundings.

Where electrical components are being changed, they shall be fit according to their purpose and to the correct specification. At all times the manufacturer's maintenance and service guidelines shall be followed. If in doubt, consult the manufacturer's technical department for assistance. The following checks shall be applied to installations using flammable refrigerants:

- The actual refrigerant charge is in accordance with the room size within which the refrigerant containing parts are installed.

- The ventilation machinery and outlets are operating adequately and are not obstructed.

- If an indirect refrigerating circuit is being used, the secondary circuit shall be checked for the presence of refrigerant.

- Equipment marking must remain visible and legible. Markings and signs that are illegible shall be corrected.

Refrigerating pipe or components are installed in a position where they are unlikely to be exposed to any substances which may corrode refrigerant containing components, unless the components are constructed of materials that are inherently resistant to corrosion or are suitably protected against corrosion.

Repair and maintenance of electrical components shall include initial safety checks and component inspection procedures. If a fault exists that could compromise safety, then no electrical supply shall be connected to the circuit until the fault has been dealt with satisfactorily.

If the fault cannot be corrected immediately but it is necessary to continue operation, an adequate temporary solution shall be used. This shall be reported to the owner of the equipment so that all parties are advised. Initial safety checks shall include:

- That capacitors are discharged: this shall be done in a safe manner to avoid the possibility of sparking.

- That no live electrical components and wiring are exposed while charging, recovering or purging the system.

- That there is continuity of earthing.

⚠ WARNING

Sealed electrical components shall be replaced.

Intrinsically safe components must be replaced.

Check that cabling will not be subject to wear, corrosion, excessive pressure, vibration, sharp edges or any other adverse environmental effects. The check shall also take into account the effects of aging or continual vibration from sources such as compressors or fans.

Under no circumstances shall potential sources of ignition be used while searching for or detection of refrigerant leaks. A halide torch (or any other detector using a naked flame) shall not be used.

Electronic leak detectors may be used to detect refrigerant leaks but, in the case of flammable refrigerants, the sensitivity may not be adequate, or may need re-calibration. (Detection equipment shall be calibrated in a refrigerant-free area.) Ensure that the detector is not a potential source of ignition and is suitable for the refrigerant used. Leak detection equipment shall be set at a percentage of the LFL of the refrigerant and shall be calibrated for the refrigerant employed, and the appropriate percentage of gas (25 % maximum) is confirmed.

If a leak is suspected, all naked flames shall be removed/extinguished.

If a leakage of refrigerant which requires brazing is found, all of the refrigerant shall be recovered from the system, or isolated (by means of shut off valves) in a part of the system remote from the leak.

Leak detection fluids are also suitable for use with most refrigerants but the use of detergents containing chlorine shall be avoided as the chlorine may react with the refrigerant and corrode the copper pipe-work.

NOTE: Examples of leak detection fluids are

- bubble method,
- fluorescent method agents.

When breaking into the refrigerant circuit to make repairs - or for any other purpose - conventional procedures shall be used. However, for flammable refrigerants it is important that best practice be followed, since flammability is a consideration. The following procedure shall be adhered to:

- safely remove refrigerant following local and national regulations.
- evacuate.
- purge the circuit with inert gas.
- evacuate.
- continuously flush or purge with inert gas when using flame to open circuit.
- open the circuit.

The refrigerant charge shall be recovered into the correct recovery cylinders if venting is not allowed by local and national codes. For appliances containing flammable refrigerants, the system shall be purged with oxygen-free nitrogen to render the appliance safe for flammable refrigerants. This process might need to be repeated several times. Compressed air or oxygen shall not be used for purging refrigerant systems.

For appliances containing flammable refrigerants, refrigerants purging shall be achieved by breaking the vacuum in the system with oxygen-free nitrogen and continuing to fill until the working pressure is achieved, then venting to atmosphere, and finally pulling down to a vacuum. This process shall be repeated until no refrigerant is within the system. When the final oxygen-free nitrogen charge is used, the system shall be vented down to atmospheric pressure to enable work to take place.

The outlet for the vacuum pump shall not be close to any potential ignition sources, and ventilation shall be available.

Ensure that contamination of different refrigerants does not occur when using charging equipment. Hoses or lines shall be as short as possible to minimise the amount of refrigerant they contain.

Cylinders shall be kept upright. Ensure that the refrigeration system is grounded prior to charging the system with refrigerant.

Label the system when charging is complete (if it is not already labeled).

Take extreme care not to overfill the refrigeration system.

Prior to recharging the system, it shall be pressure-tested with the appropriate purging gas. The system shall be leak-tested on completion of charging but prior to commissioning. A follow up leak test shall be carried out prior to leaving the site.

Before carrying out this procedure, it is essential that the technician is completely familiar with the equipment and all its detail. It is recommended that all refrigerants are recovered safely. Prior to the task being carried out, an oil and refrigerant sample shall be taken in case analysis is required prior to re-use of reclaimed refrigerant. It is essential that electrical power is available before the task is commenced.

- a) Become familiar with the equipment and its operation.
- b) Isolate system electrically.
- c) Before attempting the procedure ensure that:
 - mechanical handling equipment is available, if required, for handling refrigerant cylinders;
 - all personal protective equipment is available and being used correctly;
 - the recovery process is supervised at all times by a competent person;
 - recovery equipment and cylinders conform to the appropriate standards.
- d) Pump down refrigerant system, if possible.
- e) If a vacuum is not possible, make a manifold so that refrigerant can be removed from various parts of the system.
- f) Make sure that the cylinder is situated on the scales before recovery takes place.
- g) Start the recovery machine and operate it in accordance with the manufacturer's instructions.
- h) Do not overfill cylinders. (No more than 80 % volume liquid charge).
- i) Do not exceed the maximum working pressure of the cylinder, even temporarily.
- j) When the cylinders have been filled correctly and the process has been completed, make sure that the cylinders and the equipment are removed from site promptly and all isolation valves on the equipment are closed off.
- k) Recovered refrigerant shall not be charged into another refrigeration system unless it has been cleaned and checked.

Equipment shall be labeled stating that it has been de-commissioned and emptied of refrigerant. The label shall be dated and signed. Ensure that there are labels on the equipment stating the equipment contains flammable refrigerant.

When removing refrigerant from a system, either for servicing or decommissioning, it is recommended that all refrigerants are removed safely.

When transferring refrigerant into cylinders, ensure that only appropriate refrigerant recovery cylinders are employed. Ensure that the correct number of cylinders for holding the total system charge is available. All cylinders to be used are designated for the recovered refrigerant and labelled for that refrigerant (i.e. special cylinders for the recovery of refrigerant). Cylinders shall be complete with pressure-relief valve and associated shut-off valves in good working order. Empty recovery cylinders are evacuated and, if possible, cooled before recovery occurs.

The recovery equipment shall be in good working order with a set of instructions concerning the equipment that is at hand and shall be suitable for the recovery of the flammable refrigerant. If in doubt, the manufacturer should be consulted. In addition, a set of calibrated weighing scales shall be available and in good working order. Hoses shall be complete with leak-free disconnect couplings and in good condition.

The recovered refrigerant shall be processed according to local legislation in the correct recovery cylinder, and the relevant waste transfer note arranged. Do not mix refrigerants in recovery units and especially not in cylinders.

If compressors or compressor oils are to be removed, ensure that they have been evacuated to an acceptable level to make certain that flammable refrigerant does not remain within the lubricant. The compressor body shall not be heated by an open flame or other ignition sources to accelerate this process. When oil is drained from a system, it shall be carried out safely.

Do not use the air conditioner for other purposes.

In order to avoid any quality deterioration, do not use the unit for the cooling of precision instruments, food, plants, animals or works of art.

Before cleaning, be sure to stop the operation, turn the breaker off or unplug the supply cord. Otherwise, electric shock and injury may occur.

In order to avoid electric shock or fire, make sure that an earth leak detector is installed.

Never touch the air outlet or the horizontal blades while the swing flap is in operation. Your fingers may become caught or the unit may break down.

Never put any objects into the air inlet or outlet.

Objects touching the fan at high speed can be dangerous.

Never inspect or service the unit by yourself.

Ask a qualified service person to perform this task.

Do not dispose of this product as unsorted municipal waste. This waste should be collected separately for special treatment. Do not dispose of electrical appliances as unsorted municipal waste. Use separate collection facilities. Contact your local government for information regarding the connection systems available.

If electrical appliances are disposed of in landfills or dumps, hazardous substances can leak into the groundwater and get into the food chain, harming your health and well-being.

To prevent refrigerant leak, contact your dealer.

When the system is installed and operates in a small room, it is required to maintain the concentration of the refrigerant below the limit, in case a leak occurs. Otherwise, oxygen in the room may be affected, resulting in a serious accident.

The refrigerant in the air conditioner is safe and normally does not leak.

If the refrigerant leaks into the room and comes into contact with the fire of a burner, a heater or a cooker, a harmful gas could be released.

Turn off any combustible heating devices, ventilate the room, and contact the dealer where you purchased the unit.

Do not use the air conditioner until a service person confirms that the refrigerant leak is repaired.

Keep ventilation openings clear of obstruction.

CAUTION

Be sure the air conditioner is earthed. In order to avoid electric shock, make sure that the unit is earthed and that the earth wire is not connected to a gas or water pipe, lightning conductor or telephone earth wire.

Do not operate the air conditioner with a wet hands. An electric shock may happen.

Do not operate the air conditioner when using a room fumigation-type insecticide. Failure to observe this precaution could cause the chemicals to become deposited in the unit, which could endanger the health of those who are hypersensitive to chemicals. It may also cause the refrigerant sensor to alarm.

To avoid oxygen deficiency, ventilate the room sufficiently if equipment with a burner is used together with the air conditioner.

Arrange the drain hose to ensure smooth drainage. Incomplete drainage may cause wetting of the building, furniture, etc.

Never touch the internal parts of the controller. Do not remove the front panel. Some parts inside are dangerous to touch, and machine troubles may occur.

Attention is drawn to the fact that additional transportation regulations may exist with respect to equipment containing flammable gas. The maximum number of pieces of equipment or the configuration of the equipment permitted to be transported together will be determined by the applicable transport regulations.

Signs for similar appliances used in a work area are generally addressed by local regulations and give the minimum requirements for the provision of safety and/or health signs for a work location.

Storage package protection should be constructed such a way that mechanical damage to the equipment inside the package will not cause a leak of the REFRIGERANT CHARGE.

The maximum number of pieces of equipment permitted to be stored together will be determined by local regulations.

All required signs are to be maintained and employers should ensure that employees receive suitable and sufficient instruction and training on the meaning of appropriate safety signs and the actions that need to be taken in connection with these signs.

The effectiveness of signs should not be diminished by too many signs being placed together.

Any pictograms used should be as simple as possible and contain only essential details.

The storage of the appliance should be in accordance with the applicable regulations or instructions, whichever is more stringent.

Do not operate the air conditioner when using a room fumigation - type insecticide. Failure to observe this precaution could cause the chemicals to become deposited in the unit, which could endanger the health of those who are hypersensitive to chemicals.

Do not place appliances which produce open flame in places exposed to the air flow from the unit or under the indoor unit. It may cause incomplete combustion or deformation of the unit due to the heat.

Do not install the air conditioner in a location where flammable gas may leak out. If the gas leaks out and stays around the air conditioner, a fire may break out.

⚠ WARNING

The appliance uses R454B refrigerant.



⚠ WARNING

These instructions are exclusively intended for qualified contractors and authorized installers.

Work on the refrigerant circuit with mild flammable refrigerant in safety group A2L may only be carried out by authorized heating contractors. These heating contractors must be trained in accordance with UL 60335-2-40, Section HH. The certificate of competence from an industry accredited body is required.

Work on electrical equipment may only be carried out by a qualified electrician.

Before initial commissioning, all safety – related points must be checked by the particular certified heating contractors. The system must be commissioned by the system installer or a qualified person authorized by the installer.

⚠ CAUTION

Only use this unit in well-ventilated spaces and ensure that there are no obstructions that could impede the airflow into and out of the unit.

Do not use this unit in the following locations:

- Locations with mineral oil.
- Locations with saline atmospheres, such as seaside locations.
- Locations with sulphurous atmospheres, such as near natural hot springs.
- Where high voltage electricity is present, such as in certain industrial locations.
- On vehicles or vessels, such as trucks or ferry boats.
- Where exposure to oily or very humid air may occur, such as kitchens.
- In proximity to sources of electromagnetic radiation, such as high-frequency transmitters or other high strength radiation devices.

⚠ CAUTION

A manufactured (mobile) home installation must conform with the Manufactured Home Construction and Safety Standard, Title 24 CFR, Part 3280, or when this Standard is not applicable, the Standard for Manufactured Home Installations (Manufactured Home Sites, Communities and Set-Ups), ANSI/NCS A225.1, and/or MH Series Mobile Homes, CAN/CSA Z240.

⚠ CAUTION

This appliance is not intended for use by persons (including children) with reduced physical, sensory or mental capabilities, or lack of experience and knowledge, unless they have been given supervision or instruction concerning use of the appliance by a person responsible for their safety.

Children should be supervised to ensure that they do not play with the appliance.

2 INSTALLATION

⚠ WARNING

Ensure that apparatus is mounted securely.

⚠ WARNING

The pipe-work including piping material, pipe routing, and installation shall include protection from physical damage in operation and service, and be in compliance with national and local codes and standards, such as ASHRAE 15,ASHRAE 15.2, IAPMO Uniform Mechanical Code, ICC International Mechanical Code. Inspection prior to being covered or enclosed,or CSA B52. All field joints shall be accessible for inspection prior to being covered or enclosed.

2.1 Pre-Installation

⚠ WARNING

The appliance shall be stored so as to prevent mechanical damage from occurring.

Before installation, carefully check the following:

1. Unit should be installed in accordance with national and local safety codes, including but not limit to ANSI/NFPA No. 70 or Canadian Electrical Code Part 1, C22.1, local plumbing and wastewater codes and any other applicable codes.
2. For rooftop installation, be sure the structure has enough strength to support the weight of unit. Unit should be installed on roof curb and leveled.
3. For ground level installation, a level slab should be used.
4. Condenser airflow should not be restricted.
5. On applications when a roof curb is used, the unit must be positioned on the curb so the front of the unit is tight against the curb.

⚠ CAUTION

As soon as unit is received, it should be inspected and noted for possible shipping damage during transportation. It is carrier's responsibility to cover the cost of shipping damage. Manufacturer or distributor will not accept the claims from dealer for any transportation damage.

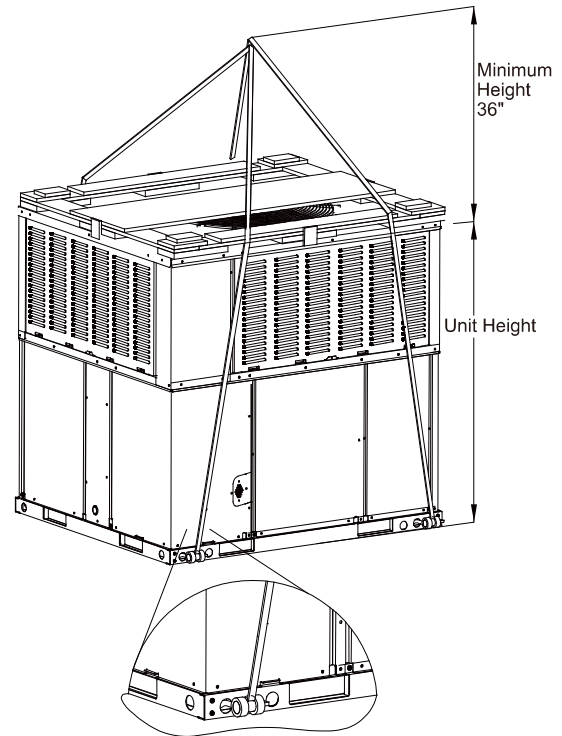

* The above figure for reference purpose only.

Fig. 2-1 Hoisting Diagram

2.2 Clearance

Refer to Fig. 2-3, 2-4, 2-6, 2-7 for unit physical data.

If components are to be added to a unit they must meet local codes, they are to be installed at the dealer's and/or the customer's expense.

Size of unit for proposed installation should be based on heat loss / heat gain calculations made in accordance with industry recognized procedures identified by the Air conditioning contractors of America.

2.3 Rigging and Handing

Exercise care when moving the unit. Do not remove any packaging until the unit is near the place of installation. Rig the unit by attaching chain or cable slings to the lifting holes provided in the base rails. Spreader bars, whose length exceeds the largest dimension across the unit, MUST be used across the top of the unit.

⚠ CAUTION

Before lifting, make sure the unit weight is distributed equally on the rigging cables so it will lift evenly.

Units may be moved or lifted with a forklift. Slotted openings in the base rails are provided for this purpose.

⚠ CAUTION

All panels must be secured in place when the unit is lifted.
The condenser coils should be protected from rigging cable damage with plywood or other suitable material.

⚠ WARNING

Check the electric wire, water and gas pipeline layout inside the wall, floor and ceiling before installation. Do not implement drilling unless confirm safety with the user, especially for the hidden power wire. An electroprobe can be used to test whether a wire is passing by at the drilling location, to prevent physical injury or death caused by insulation broken cords.

⚠ WARNING

Check the power supply before installation. Ensure that the power supply must be reliably grounded following local, state and National Electrical Codes. If not, for example, if the ground wire is detected charged, installation is prohibited before it is rectified. Otherwise, there is a risk of fire and electric shock, causing physical injury or death.

2.4 Unit Dimensions

Component Location-24K&30K&36K

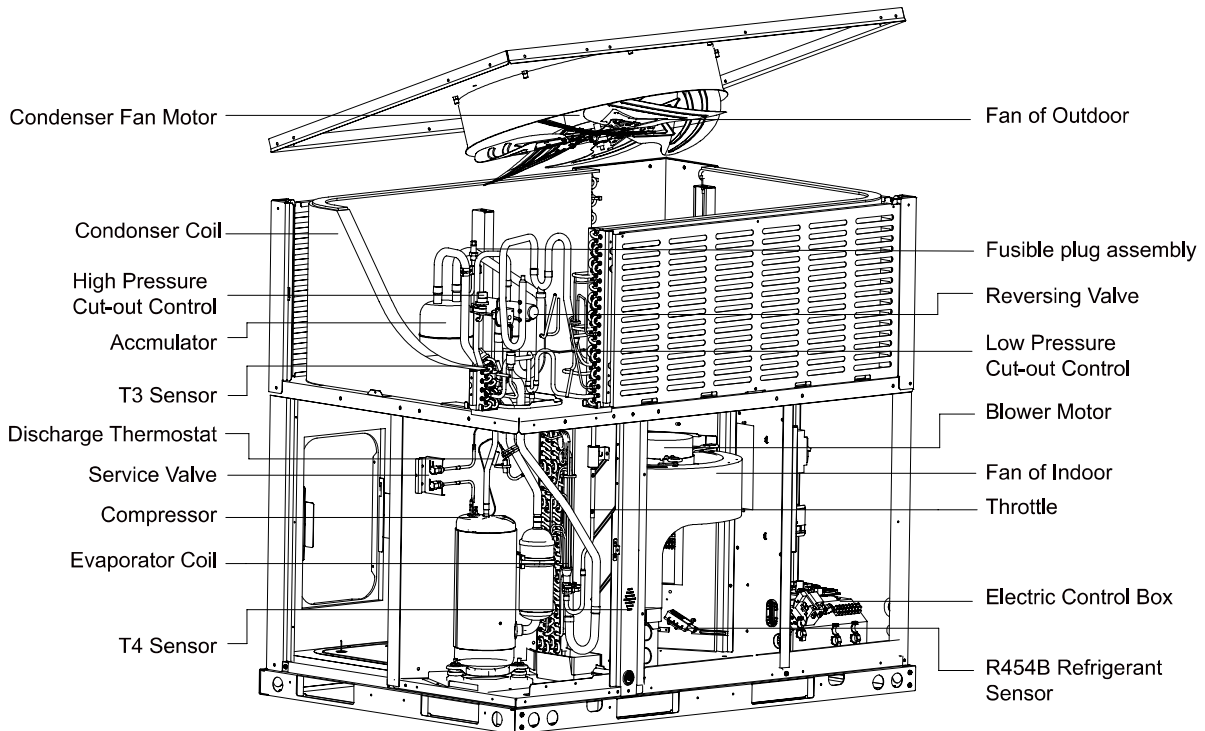

Fig. 2-2 Component Location

* The above figure for reference purpose only.

Unit Dimensions-24K&30K&36K

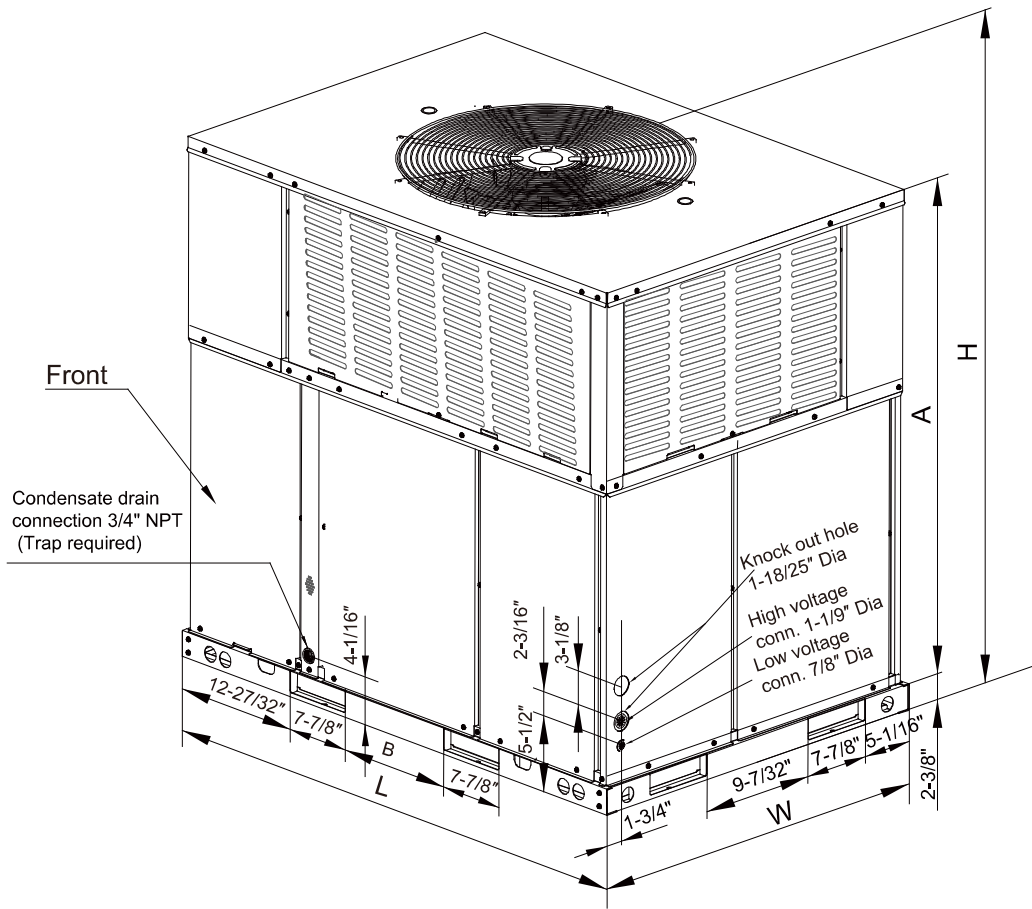

Fig. 2-3 Unit Dimensions

* The above figure for reference purpose only.

Model size	Dimensions				
Heat Pump	"L" in[mm]	"W" in[mm]	"H" in[mm]	"A" in[mm]	"B" in[mm]
24/30/36	50-11/16 [1287]	35-1/16 [891]	46-13/16 [1190]	44-1/16 [1120]	9-7/32 [234]

Table 2-1 Unit Dimensions

Dimensions Back and Bottom-24K&30K&36K

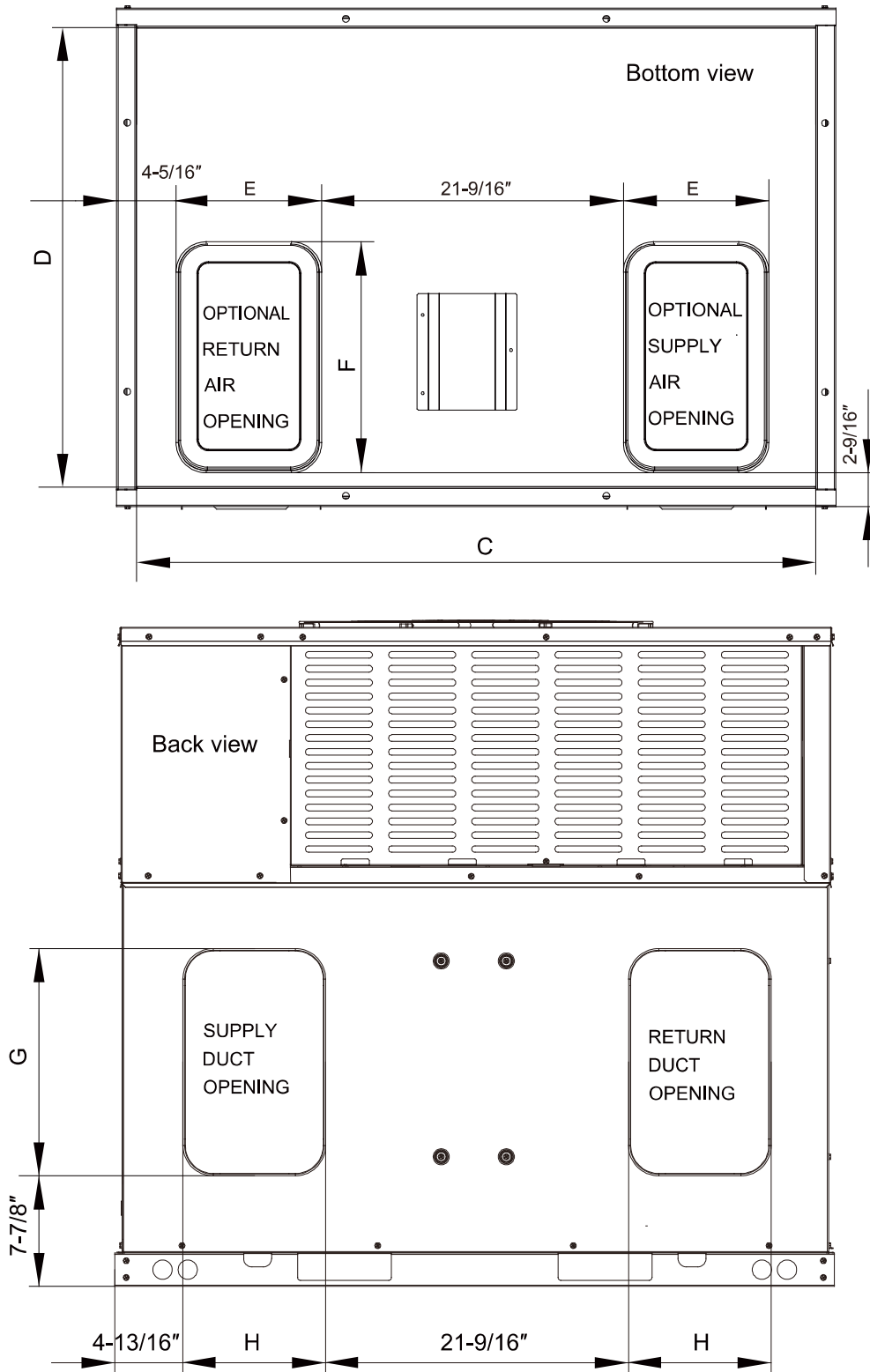

Fig. 2-4 Dimensions Back and Bottom

* The above figure for reference purpose only.

Model size	Dimensions					
Heat Pump	"C" in[mm]	"D" in[mm]	"E" in[mm]	"F" in[mm]	"G" in[mm]	"H" in[mm]
24/30/36	47-13/16 [1215]	32-1/4 [820]	9-15/16 [252]	15-7/8 [403]	15-3/4 [400]	9-3/4 [249]

Table 2-2 Unit Dimensions

Component Location-42K&48K&60K

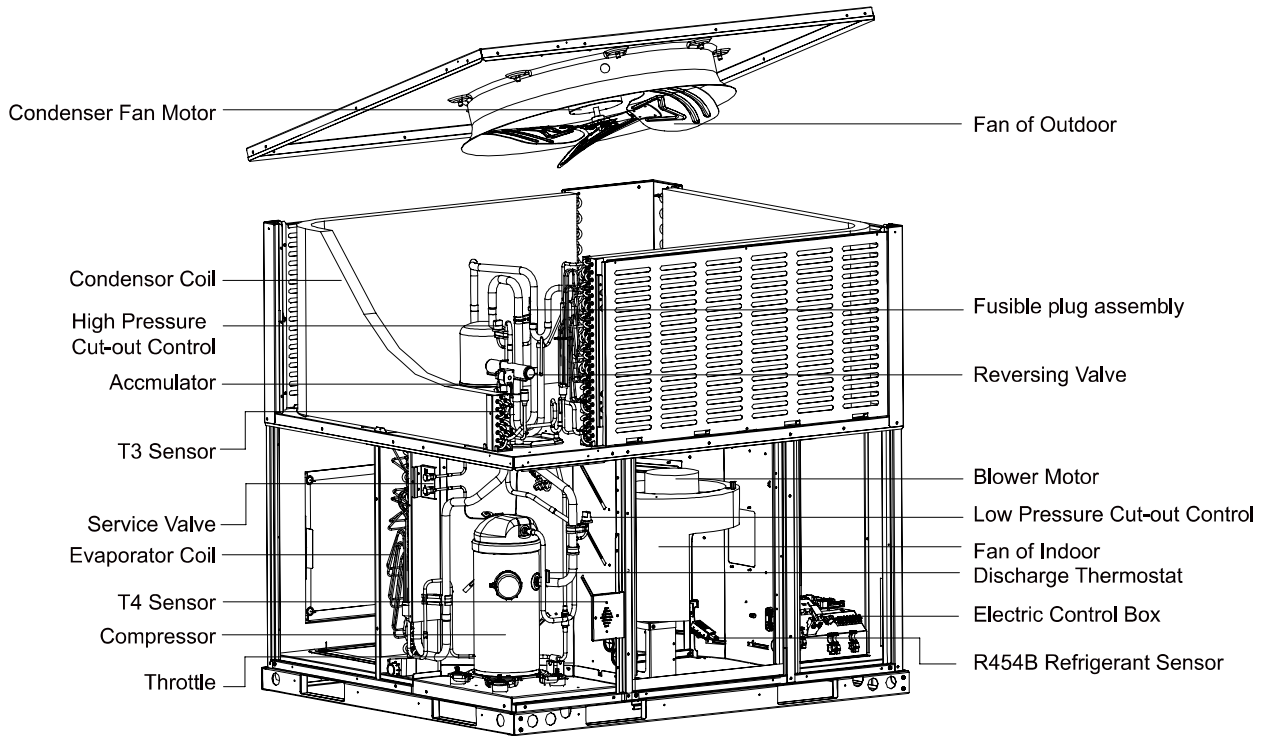

Fig. 2-5 Component Location

* The above figure for reference purpose only.

Unit Dimensions-42K&48K&60K

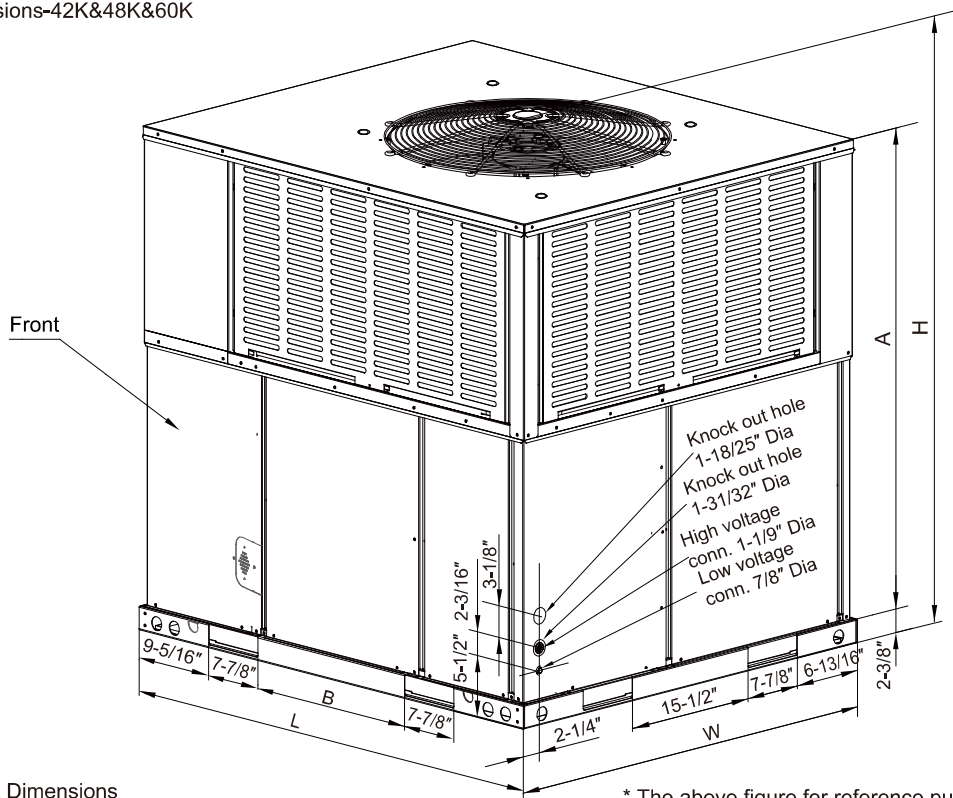

Fig. 2-6 Unit Dimensions

* The above figure for reference purpose only.

Model size	Dimensions				
Heat Pump	"L" in[mm]	"W" in[mm]	"H" in[mm]	"A" in[mm]	"B" in[mm]
42/48/60	51-9/16 [1310]	44-13/16 [1140]	51-7/16 [1306]	47-5/16 [1202]	17-5/32 [436]

Table 2-3 Unit Dimensions

Dimensions Back and Bottom-42K&48K&60k

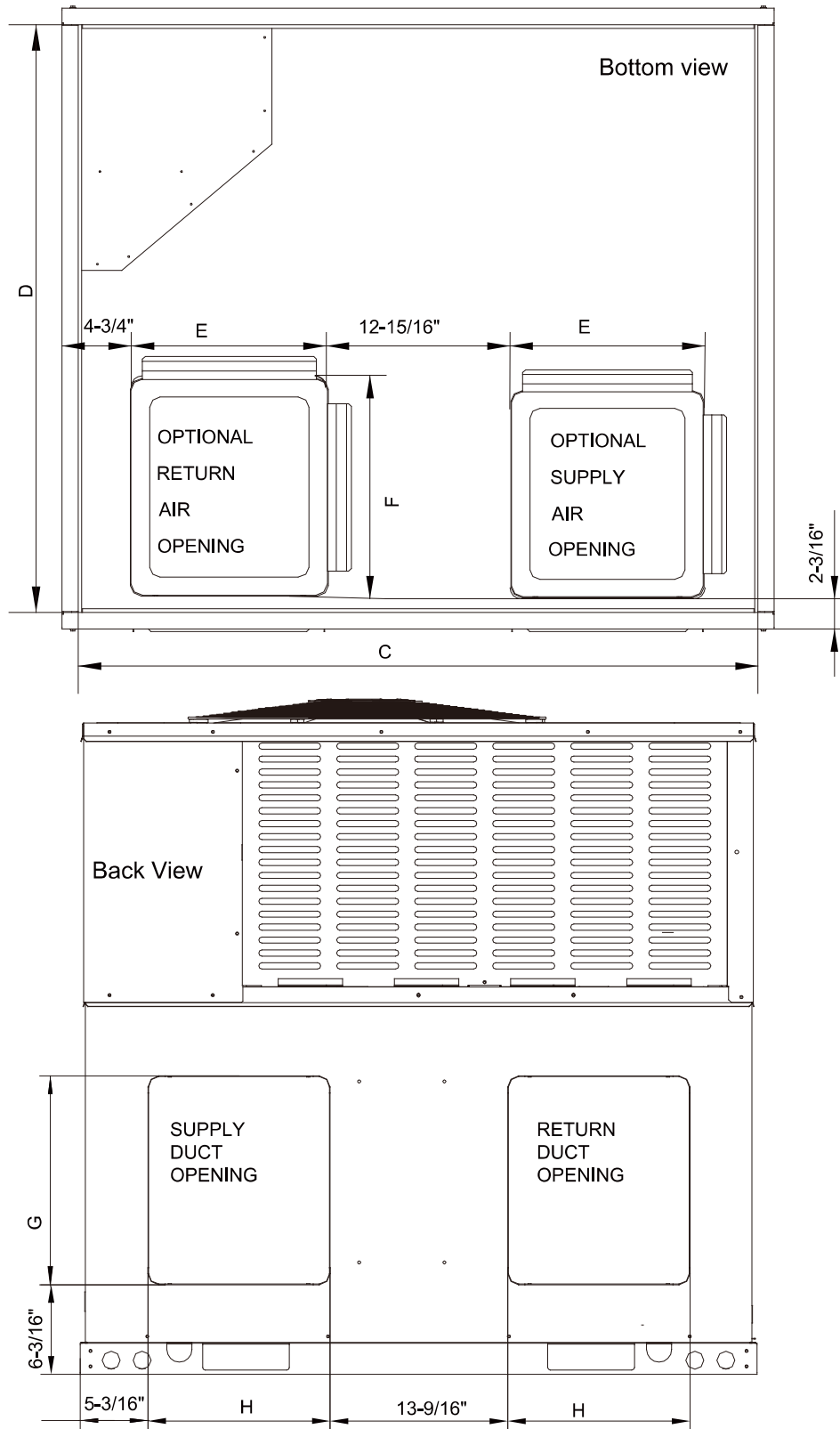

Fig. 2-7 Dimensions Back and Bottom

* The above figure for reference purpose only.

Model size	Dimensions					
Heat Pump	"C" in[mm]	"D" in[mm]	"E" in[mm]	"F" in[mm]	"G" in[mm]	"H" in[mm]
42/48/60	49-1/4 [1250]	42-1/2 [1080]	14-1/8 [358]	16-1/8 [409]	15-7/8 [403]	13-7/8 [352]

Table 2-4 Unit Dimensions

NOTICE

For units applied with a roof curb, the minimum clearance may be reduced from 1 inch to 1/2 inch between combustible roof curb material and this supply air duct.

2.5 Roof Curb

On applications when a roof curb is used, the unit must be positioned on the curb so the front of the unit is tight against the curb. (See Fig. 2-8 ROOF CURB DIMENSION)

NOTICE

For units applied with a roof curb, the minimum clearance may be reduced from 1 inch to 1/2 inch between combustible roof curb material and this supply air duct.

Roof Curb Dimension

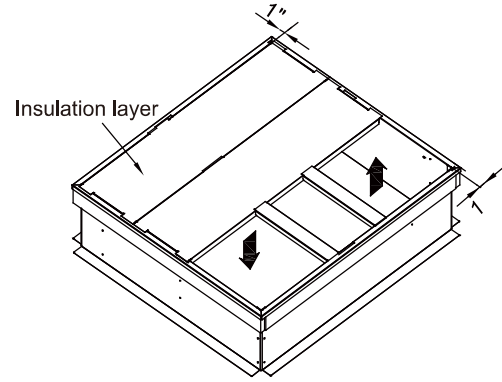

Supply and return air (including duct support rails) shown are typical for bottom duct applications. For location of horizontal duct applications (on back of unit), refer to unit dimension details.

Fig. 2-8

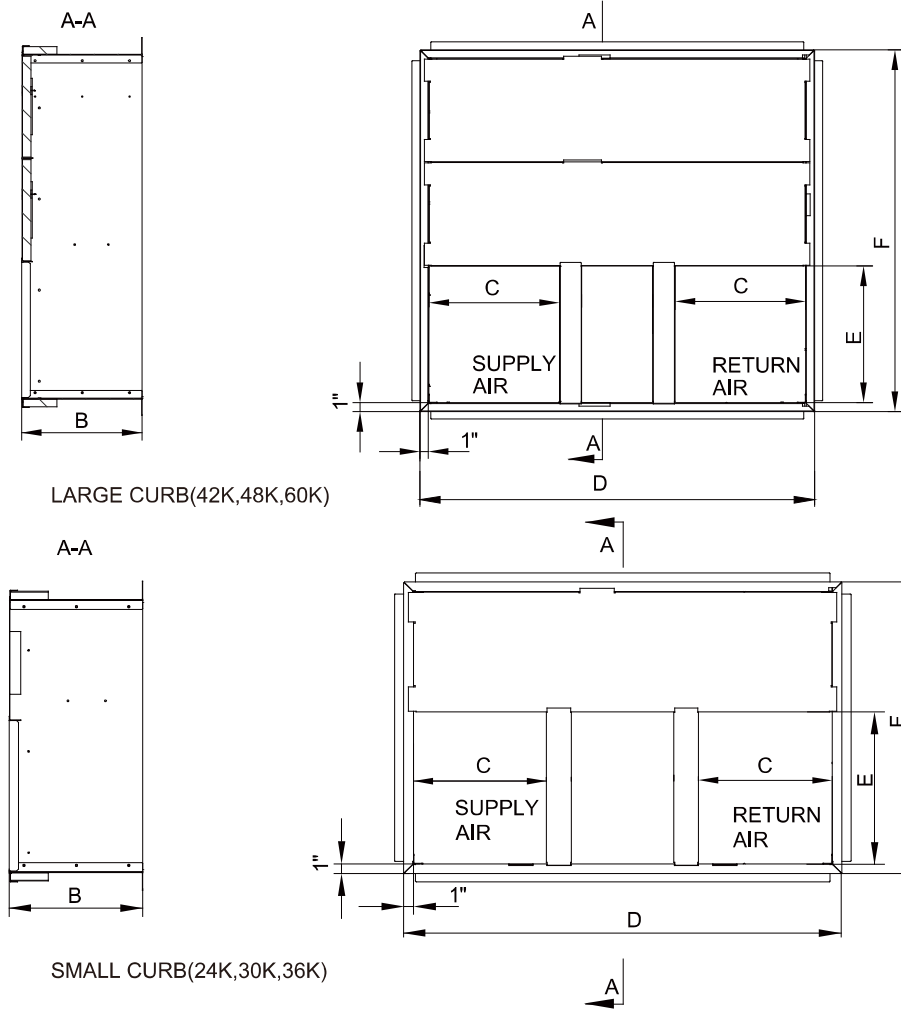

Fig. 2-9 Roof Curb Details

* The above figure for reference purpose only.

CURB	Dimensions(Inches)				
	"B" in[mm]	"C" in[mm]	"D" in[mm]	"E" in[mm]	"F" in[mm]
LARGE	14-1/4 [362]	15-1/4 [387]	46-1/16 [1170]	16 [406]	42-3/16 [1070]
SMALL	14-1/4 [362]	14 [356]	46-1/16 [1170]	16 [406]	30-5/8 [778]

Table 2-5 Unit Dimensions

NOTICE

All panels must be secured in place when the unit is lifted. The condenser coils should be protected from rigging cable damage with plywood or other suitable material.

2.6 Location Restrictions

Ensure the top discharge area is unrestricted for at least 60 inches above the unit.

Do not locate outdoor unit near bedrooms since normal operational sounds may be objectionable.

Position unit to allow adequate space for unobstructed airflow, wiring, refrigerant lines, and serviceability.

Allow a minimum of 12 in. clearance on one side of access panel to a wall and a minimum of 24 in. on the adjacent side of access panel.

Maintain a distance of 24 in. between units.

Position unit where water, snow, or ice from roof or overhang cannot fall directly on unit. (See Fig.2-11 and Fig.2-12.)

CAUTION:

Cold climate considerations (heat pump only)

NOTICE

Precautions must be taken for units being installed in areas where snow accumulation and prolonged below-freezing temperatures occur.

- Units should be elevated 3-12 inches above the pad or rooftop, depending on local weather. This additional height will allow drainage of snow and ice melted during defrost cycle prior to its refreezing. Ensure that drain holes in unit base pan are not obstructed, preventing drainage of defrost water (See Fig.2-13).
- If possible, avoid locations that are likely to accumulate snow drifts. If not possible, a snow drift barrier should be installed around the unit to prevent a build-up of snow on the sides of the unit.

NOTICE

Make sure that Condensate Drain side is not higher than the other side (Fig.2-10).

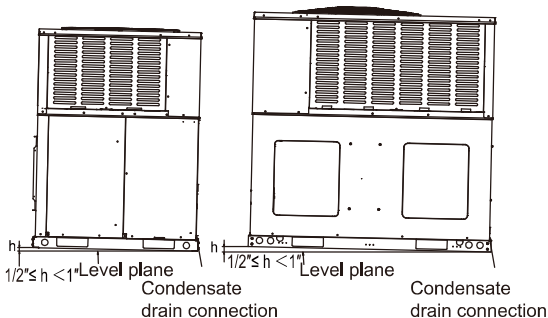

* The above figure for reference purpose only.

Fig. 2-10 Slab installation

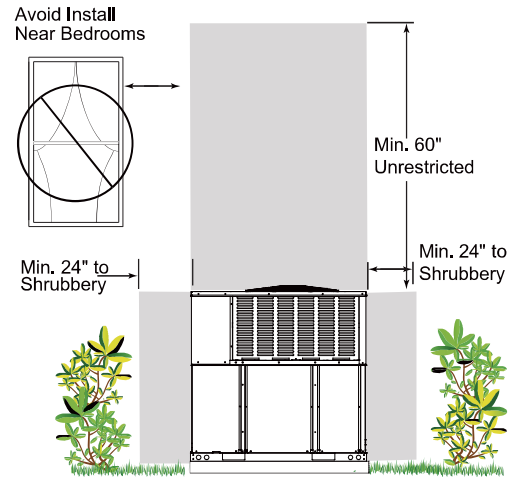

Fig. 2-11

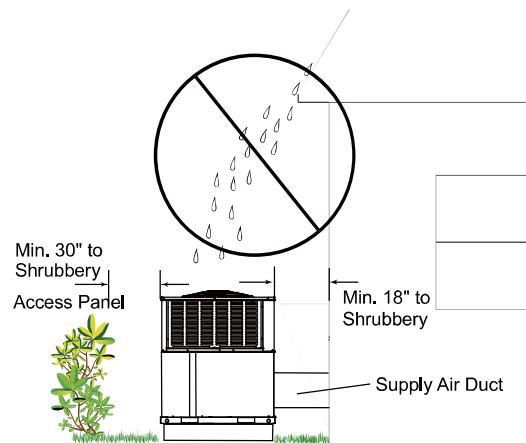

Fig. 2-12

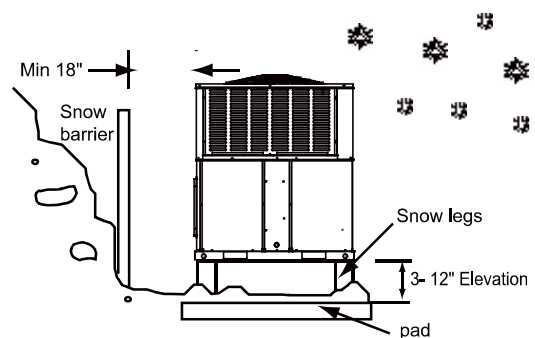

Fig. 2-13

2.7 Refrigerant Charge and Room Area Limitations

In UL/CSA 60335-2-40, R454B refrigerant is classified as class A2L, which is mildly flammable. Therefore, R454B refrigerant will limit the area of the rooms being served by the system.

Similarly, the total amount of refrigerant in the system shall be less than or equal to the allowable maximum refrigerant charge. The allowable maximum refrigerant charge depends on the area of the rooms being served by the system.

NOTICE

The abbreviations in this section are explained as follows:

m_c : The actual refrigerant charge in the system.
 A : the actual room area where the appliance is installed.

A_{min} : The required minimum room area.
 m_{max} : The allowable maximum refrigerant charge in a room.

Q_{min} : The minimum circulation airflow.

Anv_{min} : The minimum opening area for connected rooms.

TA_{min} : The required minimum total area of the conditioned space (For appliances serving two or more rooms with an air duct system).

TA : The total area of the conditioned space connected by air ducts. (For appliances serving two or more rooms with an air duct system).

2.7.1 The room area calculation requirements

CAUTION

The space considered shall be any space which contains refrigerant-containing parts or into which refrigerant could be released.

The height of the room where the air conditioning system is installed must be at least 86-39/64 in (2.2 m).

The room area (A) of the smallest, enclosed, occupied space shall be used in the determination of the refrigerant quantity limits.

For determination of room area (A) when used to calculate the refrigerant charge limit, the following shall apply.

The room area (A) shall be defined as the room area enclosed by the projection to the base of the walls, partitions and doors of the space in which the appliance is installed.

Spaces connected by only drop ceilings, ductwork, or similar connections shall not be considered a single space.

Units mounted higher than 70-55/64 inches and spaces divided by partition walls that are no higher than 62-63/64 inches shall be considered a single space.

Rooms on the same floor and connected by an open passageway between the spaces can be considered a single room when determining compliance to A_{min} , if the passageway complies with all of the following.

- 1) It is a permanent opening.
- 2) It extends to the floor.
- 3) It is intended for people to walk through.

The area of the connected rooms, on the same floor, connected by permanent opening in the walls and/or doors between occupied spaces, including gaps between the wall and the floor, can be considered a single room when determining compliance to A_{min} , provided all of the following conditions are met as Fig. 2-14.

1) Low level opening

- ① The opening shall not be less than Anv_{min} in Table 2-6.
- ② The area of any openings above 11-13/16 inches from the floor shall not be considered in determining compliance with Anv_{min} .
- ③ At least 50 % of the opening area of Anv_{min} shall be below 7-7/8 inches from the floor.
- ④ The bottom of the opening is not more than 3-15/16 inches from the floor.

⑤ The opening is a permanent opening that cannot be closed.

⑥ For openings extending to the floor the height shall not be less than 25/32 inches above the surface of the floor covering.

2) High level opening

- ① The opening shall not be less than 50 % of Anv_{min} in Table 2-6.
- ② The opening is a permanent opening that cannot be closed.
- ③ The opening shall be at least 59 inches above the floor.
- ④ The height of the opening is not less than 25/32 inches.

3) Room size requirement

- ① The room into which refrigerant can leak, plus the connected adjacent room(s) shall have a total area not less than A_{min} . A_{min} is shown in Table 2-8.
- ② The room area in which the unit is installed shall be not less than 20 % A_{min} . A_{min} is shown in Table 2-8.

NOTICE

The requirement for the second opening can be met by drop ceilings, ventilation ducts, or similar arrangements that provide an airflow path between the connected rooms.

The minimum opening for natural ventilation (Anv_{min}) in connected rooms is related to the room area (A), the actual refrigerant charge of refrigerant in the system (m_c), and the allowable MAXIMUM REFRIGERANT CHARGE in the system (m_{max}), Anv_{min} can be determined according to Table 2-6.

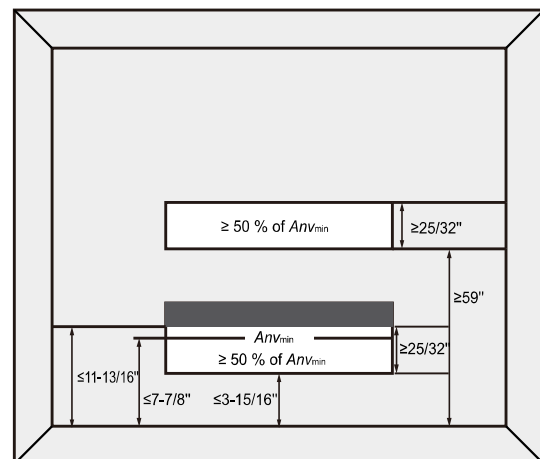

Fig. 2-14 Opening conditions for connected rooms

The minimum opening area for connected rooms

A		m _c		m _{max}		Anv _{min}	
ft ²	m ²	lb-oz	kg	lb-oz	kg	ft ²	m ²
100	9.30	17-3	7.8	6-10	3.0	1.3	0.12
110	10.30	17-3	7.8	7-5	3.3	1.2	0.11
120	11.20	17-3	7.8	8-0	3.6	1.1	0.10
130	12.10	17-3	7.8	8-10	3.9	1.0	0.10
140	13.10	17-3	7.8	9-5	4.2	1.0	0.09
150	14.00	17-3	7.8	10-0	4.5	0.9	0.08
160	14.90	17-3	7.8	10-10	4.8	0.8	0.07
170	15.80	17-3	7.8	11-5	5.1	0.7	0.07
180	16.80	17-3	7.8	12-0	5.4	0.6	0.06
190	17.70	17-3	7.8	12-10	5.7	0.5	0.05
200	18.60	17-3	7.8	13-5	6.0	0.5	0.04
210	19.60	17-3	7.8	14-0	6.3	0.4	0.04
220	20.50	17-3	7.8	14-10	6.6	0.3	0.03
230	21.40	17-3	7.8	15-5	6.9	0.2	0.02
240	22.30	17-3	7.8	16-0	7.2	0.1	0.01
250	23.30	17-3	7.8	16-10	7.5	0.1	0.01
260	24.20	17-3	7.8	17-5	7.8	0.0	0.00

Table 2-6

Note: Take the m_c=17 lb 3 oz as an example.

For appliances serving two or more rooms with an air duct system, The room area calculation shall be determined based on the total area of the conditioned space (TA) connected by ducts taking into consideration that the circulating airflow distributed to all the rooms by the appliance integral indoor fan will mix and dilute the leaking refrigerant before entering any room.

2.7.2. The allowed maximum refrigerant charge and required minimum room area

If the fan incorporated to an appliance is continuously operated or operation is initiated by a REFRIGERANT DETECTION SYSTEM with a sufficient CIRCULATION AIRFLOW rate, the allowable maximum refrigerant charge (m_{max}) and the required minimum room area (A_{min}/TA_{min}) is shown in Table 2-7 and Table 2-8.

The allowable maximum refrigerant charge

A/TA		m _{max}		A/TA		m _{max}	
ft ²	m ²	lb-oz	kg	ft ²	m ²	lb-oz	kg
60	5.6	4-0	1.8	170	15.8	11-5	5.1
70	6.5	4-10	2.1	180	16.8	12-0	5.4
80	7.5	5-5	2.4	190	17.7	12-10	5.7
90	8.4	6-0	2.7	200	18.6	13-5	6.0
100	9.3	6-10	3.0	210	19.6	14-0	6.3
110	10.3	7-5	3.3	220	20.5	14-10	6.6
120	11.2	8-0	3.6	230	21.4	15-5	6.9
130	12.1	8-10	3.9	240	22.3	16-0	7.2
140	13.1	9-5	4.2	250	23.3	16-10	7.5
150	14.0	10-0	4.5	260	24.2	17-5	7.8
160	14.9	10-10	4.8				

Table 2-7

The required minimum room area

m _c		A _{min} /TA _{min}		m _c		A _{min} /TA _{min}	
lb-oz	kg	ft ²	m ²	lb-oz	kg	ft ²	m ²
3-15	1.8	59.5	5.6	11-0	5.0	165.3	15.4
4-6	2.0	66.1	6.2	11-7	5.2	171.9	16.0
4-13	2.2	72.7	6.8	11-14	5.4	178.5	16.6
5-4	2.4	79.3	7.4	12-5	5.6	185.1	17.2
5-11	2.6	86.0	8.0	12-12	5.8	191.7	17.9
6-2	2.8	92.6	8.7	13-3	6.0	198.4	18.5
6-9	3.0	99.2	9.3	13-10	6.2	205.0	19.1
7-0	3.2	105.8	9.9	14-1	6.4	211.6	19.7
7-7	3.4	112.4	10.5	14-8	6.6	218.2	20.3
7-15	3.6	119.0	11.1	14-15	6.8	224.8	20.9
8-6	3.8	125.6	11.7	15-6	7.0	231.4	21.5
8-13	4.0	132.2	12.3	15-14	7.2	238.0	22.2
9-4	4.2	138.8	12.9	16-5	7.4	244.6	22.8
9-11	4.4	145.5	13.6	16-12	7.6	251.2	23.4
10-2	4.6	152.1	14.2	17-3	7.8	257.9	24.0
10-9	4.8	158.7	14.8				

Table 2-8

The minimum circulation airflow

m _c		Q _{min}		m _c		Q _{min}	
lb-oz	kg	CFM	m ³ /h	lb-oz	kg	CFM	m ³ /h
3-15	1.8	107	182	11-0	5.0	298	506
4-6	2.0	119	202	11-7	5.2	310	527
4-13	2.2	131	223	11-14	5.4	322	547
5-4	2.4	143	243	12-5	5.6	334	567
5-11	2.6	155	263	12-12	5.8	346	588
6-2	2.8	167	284	13-3	6.0	358	608
6-9	3.0	179	304	13-10	6.2	370	629
7-0	3.2	191	325	14-1	6.4	382	649
7-7	3.4	203	345	14-8	6.6	394	669
7-15	3.6	215	365	14-15	6.8	406	690
8-6	3.8	227	386	15-6	7.0	418	710
8-13	4.0	239	406	15-14	7.2	430	731
9-4	4.2	251	426	16-5	7.4	442	751
9-11	4.4	263	447	16-12	7.6	454	771
10-2	4.6	275	467	17-3	7.8	466	792
10-9	4.8	287	488				

Table 2-9

⚠ CAUTION

The allowable maximum refrigerant charge of the Table 2-7 or the required minimum room area of the Table 2-8 is available only if the following conditions are met:

Minimum velocity of 3.28 ft/s, which is calculated as the indoor unit airflow divided by the nominal face area of the outlet. And the grill area shall not be deducted.

Minimum airflow rate must meet the corresponding values in Table 2-9, which is related to the actual refrigerant charge of the system (m_c).

NOTICE

The maximum refrigerant limit described above applies to unventilated areas. If adding additional measures, such as areas with mechanical ventilation or natural ventilation, The maximum refrigerant charge can be increased or the minimum room area can be reduced.

CAUTION

If the actual room area, air outlet height, and refrigerant charge amount are not reflected in the above table, more severe cases need to be considered according to the data in the Tables 2-6, 2-7, 2-8, 2-9.

● Installation scheme flow chart

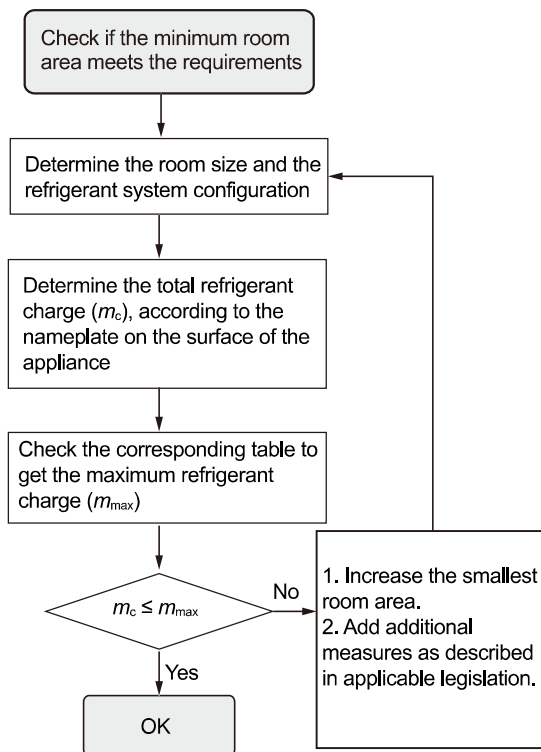

Fig. 2-15

2.8 R454B Refrigerant Sensor

R454B refrigerant leakage sensor is configured for the all units.

Failure to install R454B refrigerant leakage sensor will result in potentially hazardous conditions and improper equipment operation, and void all system warranties and liabilities. All units are shipped with the R454B Refrigerant Sensor located on the back side of the slope coil (Fig. 2-16).

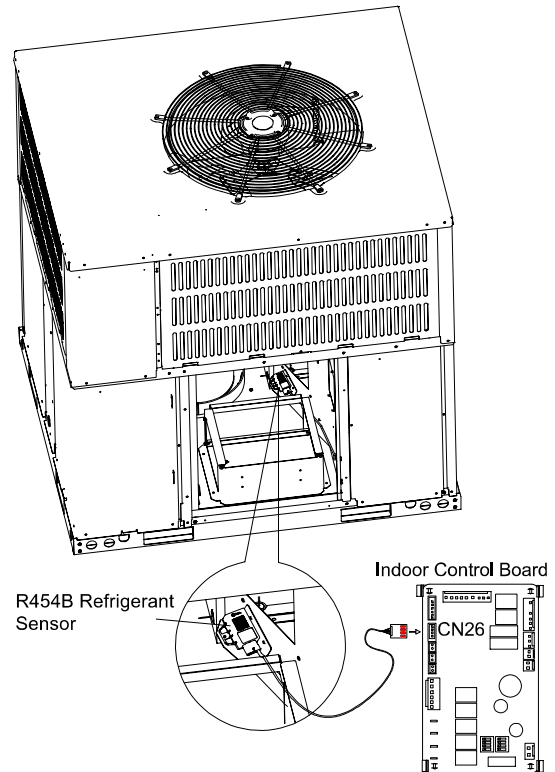

Fig. 2-16

The R454B Refrigerant Sensor is attached to a wiring harness that connects the sensor to the control board. Refer to Chapter 7 for low voltage field connections between the control board and the thermostat. All control wires are labeled with the wire function and landing point.

Power on the unit and verify proper functioning of equipment. The green LED on the indoor control board should be steady. If flash codes are present, see Table 13-1.

⚠ CAUTION

The R454B refrigerant sensor can only use the factory model or the specified model indicated in the corresponding manual.

The R454B refrigerant sensor must be used to activate the refrigerant shut-off device, the alarm device, incorporated circulation airflow or other emergency controls, which shall give an electrical signal at a predetermined alarm set point in response to leaked refrigerant.

The installation of the R454B refrigerant sensor shall allow access for checking, repair or replacement by an authorized person.

The R454B refrigerant sensor shall be installed so its function can be verified easily.

The R454B refrigerant sensor shall be protected to prevent tampering or unauthorized resetting of the pre-set value.

To be effective, the R454B refrigerant sensor must be electrically powered at all times after installation, other than when servicing.

If the R454B refrigerant sensor detects a refrigerant leak, the fan will be turned on to the maximum, and the compressor will stop running. You should immediately leave the leak area and notify a professional for handling.

The service life of the R454B refrigerant sensor is 15 years, and it should be replaced after the service life.

To ensure the detection accuracy of the R454B refrigerant sensor, it is recommended to blow dust off the surface of the R454B refrigerant sensor after it is used for a long time.

⚠ WARNING

LEAK DETECTION SYSTEM installed on the unit. Unit must be powered except for service.

NOTICE

R454B refrigerant leakage sensor is configured for the unit, the operation of fan can be initiated by R454B refrigerant sensor. Meets the incorporated circulation airflow requirements. The allowed maximum refrigerant charge (m_{max}) and the required minimum room area (A_{min}) can be determined according to Table 2-7 and Table 2-8.

3 AIRFLOW PERFORMANCE

Airflow performance data is based on cooling performance with a coil and no filter in place. Use this performance table for appropriate unit size, external static applied to unit and allow operation within the minimum and maximum limits shown in table below for both cooling and electric heat operation.

3.1 Airflow Performance Data

Model Number	Motor Speed		External Static Pressure-Inches W.C.[kPa]									
			0[0]	0.1[.02]	0.2[.05]	0.3[.07]	0.4[.10]	0.5[.12]	0.58	0.6[.15]	0.7[.17]	0.8[.20]
24	Low	SCFM	972.2	890.7	829	765.6	700.7	597.1	533.2	527.1	472.3	411.7
		Current/A	1.02	0.99	0.97	0.95	0.93	0.9	0.89	0.88	0.85	0.83
		Power/W	235	229	224	219	214	207	204	202	194	188
	Middle-Factory	SCFM	1192.8	1121.8	1058.6	992.5	920.5	849.5	788.8	773.2	638.3	565
		Current/A	1.38	1.35	1.32	1.29	1.26	1.23	1.21	1.2	1.16	1.12
		Power/W	316	309	303	295	286	278	271	269	258	245
	High	SCFM	1331.3	1259.4	1185.9	1113.4	1035.4	961.3	900.1	884.2	796	640.8
		Current/A	1.63	1.6	1.57	1.54	1.5	1.47	1.44	1.44	1.4	1.35
		Power/W	367	358	350	341	331	321	314	312	301	290
30	Low (Tap2)	CFM	1145.1	1088	1001.4	952.5	897.7	840.7	779.9	761.3	686.4	619
		Current/A	1.86	1.9	1.95	1.98	2.02	2.05	2.1	2.1	2.14	2.19
		Power/W	190	200	200	210	211	220	229	230	232	240
	Middle (Tap3)-Factory	CFM	1279.3	1233.8	1142	1095.8	1054.2	1006.1	969.8	959.6	887.5	821
		Current/A	2.28	2.33	2.39	2.43	2.46	2.51	2.54	2.55	2.62	2.67
		Power/W	258	260	270	280	281	290	298	300	310	317
	High (Tap4)	CFM	1458.9	1420.2	1376.1	1287.4	1250.4	1212.5	1179.1	1171.5	1132.4	1090.5
		Current/A	3.03	3.1	3.15	3.23	3.28	3.33	3.37	3.37	3.43	3.48
		Power/W	370	380	390	400	410	415	420	420	430	440
36	Low (Tap3)	CFM	1279.3	1233.8	1142	1095.8	1054.2	1006.1	969.8	959.6	887.5	821
		Current/A	2.28	2.33	2.39	2.43	2.46	2.51	2.54	2.55	2.62	2.67
		Power/W	258	260	270	280	281	290	298	300	310	317
	Middle (Tap4)	CFM	1458.9	1420.2	1376.1	1287.4	1250.4	1212.5	1179.1	1171.5	1132.4	1090.5
		Current/A	3.03	3.1	3.15	3.23	3.28	3.33	3.37	3.37	3.43	3.48
		Power/W	370	380	390	400	410	415	420	420	430	440
	High (Tap5)-Factory	CFM	1516.3	1477.6	1436.4	1344.6	1308	1270.3	1239	1230.7	1194.1	1154.8
		Current/A	3.3	3.37	3.43	3.52	3.56	3.61	3.65	3.66	3.71	3.76
		Power/W	410	420	430	445	450	460	462	464	470	480
42	Low (Tap2)	CFM	1425.7	1365.3	1297.9	1230.9	1161.2	1097.1	1043	1027	952.8	876.1
		Current/A	1.99	2.05	2.11	2.17	2.23	2.3	2.37	2.38	2.46	2.53
		Power/W	210	220	230	240	250	260	270	270	280	290
	Middle (Tap3)-Factory	CFM	1604.2	1550.3	1493.9	1431.4	1371.7	1311.9	1252.6	1253.4	1189.8	1126.2
		Current/A	2.52	2.58	2.66	2.73	2.8	2.87	2.93	2.95	3.03	3.11
		Power/W	290	300	310	320	330	341	350	355	370	380
	High (Tap4)	CFM	1934.1	1992.4	1884.3	1797	1742.7	1690.4	1653.4	1643.3	1590.5	1540.7
		Current/A	3.38	3.93	4.01	4.09	4.18	4.27	4.33	4.34	4.43	4.52
		Power/W	490	500	511	529	540	551	560	562	580	590
48	Low-Factory	CFM	2058.5	2017.5	1975.1	1923.7	1856.0	1778.7	1705.2	1688.2	1585.0	1467.7
		Current/A	3.47	3.39	3.31	3.23	3.12	3.04	1.32	2.88	2.75	2.62
		Power/W	804	784	766	746	720	691	665	659	623	588
	Middle	CFM	2192.0	2145.0	2092.0	2033.7	1962.6	1873.8	1798.0	1778.4	1659.7	1537.7
		Current/A	3.81	3.72	3.63	3.53	3.43	3.31	3.21	3.18	3.04	2.9
		Power/W	881	860	838	813	786	755	728	721	682	643
	High	CFM	2320.9	2262.0	2200.0	2133.0	2051.4	1950.8	1872.0	1848.7	1730.0	1603.7
		Current/A	4.18	4.08	3.98	3.88	3.77	3.64	3.54	3.52	3.37	3.24
		Power/W	963	937	912	885	857	823	796	788	749	710
60 (208/230 V~ 60 Hz)	Low (Tap3)	CFM	1604.2	1550.3	1493.9	1431.4	1371.7	1311.9	1252.6	1253.4	1189.8	1126.2
		Current/A	2.52	2.58	2.66	2.73	2.8	2.87	2.93	2.95	3.03	3.11
		Power/W	290	300	310	320	330	341	350	355	370	380
	Middle (Tap4)	CFM	1934.1	1992.4	1884.3	1797	1742.7	1690.4	1653.4	1643.3	1590.5	1540.7
		Current/A	3.38	3.93	4.01	4.09	4.18	4.27	4.33	4.34	4.43	4.52
		Power/W	490	500	511	529	540	551	560	562	580	590
	High (Tap5)-Factory	CFM	2033.1	1984.5	1939	1891.9	1837.6	1788	1748.9	1739.8	1687.2	1640.2
		Current/A	4.35	4.42	4.48	4.56	4.65	4.73	4.8	4.81	4.9	4.99
		Power/W	567	575	586	599	610	620	630	634	650	660

Model Number	Motor Speed		External Static Pressure-Inches W.C.[kPa]									
			0[0]	0.1[.02]	0.2[.05]	0.3[.07]	0.4[.10]	0.5[.12]	0.58	0.6[.15]	0.7[.17]	0.8[.20]
60 (208/230 V 3~ 60 Hz)	Low (Tap3)	SCFM	1604.2	1550.3	1493.9	1431.4	1371.7	1311.9	1252.6	1253.4	1189.8	1126.2
		Current/A	2.52	2.58	2.66	2.73	2.8	2.87	2.93	2.95	3.03	3.11
		Power/W	290	300	310	320	330	341	350	355	370	380
	Middle (Tap4)	SCFM	1934.1	1992.4	1884.3	1797	1742.7	1690.4	1653.4	1643.3	1590.5	1540.7
		Current/A	3.38	3.93	4.01	4.09	4.18	4.27	4.33	4.34	4.43	4.52
		Power/W	490	500	511	529	540	551	560	562	580	590
	High (Tap5)- Factory	SCFM	2033.1	1984.5	1939	1891.9	1837.6	1788	1748.9	1739.8	1687.2	1640.2
		Current/A	4.35	4.42	4.48	4.56	4.65	4.73	4.8	4.81	4.9	4.99
		Power/W	567	575	586	599	610	620	630	634	650	660

Table 3-1

- The air distribution system has the greatest effect on airflow. The duct system is totally controlled by the contractor. For this reason, the contractor should use only industry-recognized procedures.
- Heat pump systems require a specified airflow. Each ton of cooling requires between 350 and 450 cubic feet of air per minute (CFM), or 400 CFM nominally.
- Duct design and construction should be carefully done. System performance can be lowered dramatically through bad planning or workmanship.
- Air supply diffusers must be selected and located carefully. They must be sized and positioned to deliver treated air along the perimeter of the space. If they are too small for their intended airflow, they become noisy. If they are not located properly, they cause drafts. Return air grilles must be properly sized to carry air back to the blower. If they are too small, they also cause noise.
- The installers should balance the air distribution system to ensure proper quiet airflow to all rooms in the home. This ensures a comfortable living space.
- An air velocity meter or airflow hood can give a reading of system CFM.
- When installation, installer should select the air speed according to the actual setting static pressure. Please refer to the Table 3-1 AIRFLOW PERFORMANCE DATA.

4 DUCTWORK

Ductwork should be sized and installed by the installing contractor in accordance with the Manual D from the Air Conditioning Contractors of America, and all national, state and local codes.

⚠ WARNING

If appliances connected via an air duct system to one or more rooms are installed in a room with an area less than shown in section "Refrigerant Charge and Room Area Limitations" Table 2-8, that room shall be without continuously operating open flames (e.g. an operating gas appliance) or other potential ignition sources (for e.g. an operating electric heater, hot surfaces). A flame-producing device may be installed in the same space if the device is provided with an effective flame arrest.

For appliances connected via an air duct system to one or more rooms, auxiliary devices which may be a potential ignition source shall not be installed in the duct work. Examples of such potential ignition sources are hot surfaces with a temperature exceeding 700 °C and electric switching devices.

For appliances connected via an air duct system to one or more rooms, only auxiliary devices approved by the appliance manufacturer or declared suitable with the refrigerant shall be installed in connecting ductwork.

NOTICE

On ductwork exposed to outside air space, use at least 2" of insulation and a vapor barrier. Flexible joint may be used to reduce noise.

A closed return duct system shall be used. This shall not preclude use of economizers or ventilation air intake. Flexible joints may be used in the supply and return duct work to minimize the transmission of noise.

⚠ CAUTION

When fastening duct work to the side duct flanges on the unit, insert the screws through the duct flanges only. DO NOT insert the screws through the casing. Outdoor duct work must be insulated and waterproofed.

NOTICE

Be sure to note supply and return openings. Refer to Fig. 4-2 for information concerning supply and return air duct openings.

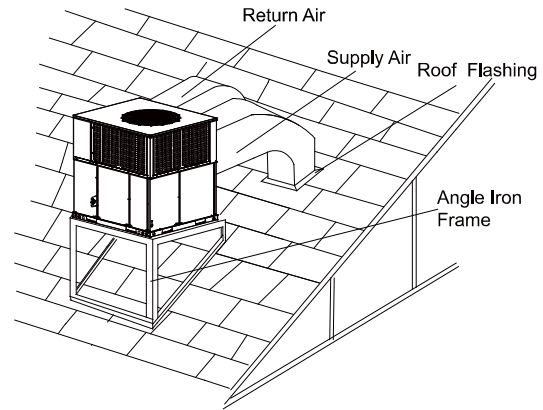

Fig. 4-1 Rooftop Installation—Frame Mounting

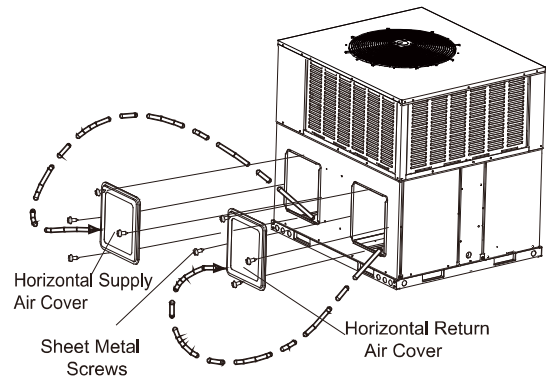

Fig. 4-2

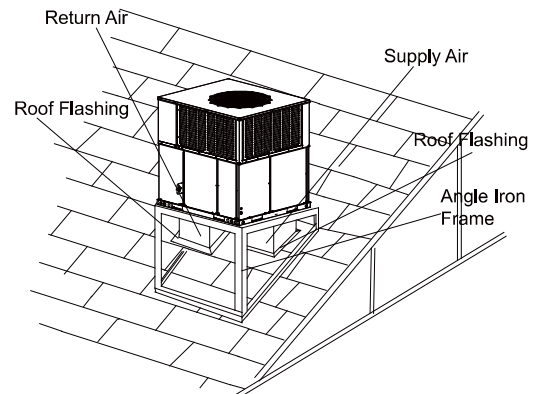

Fig. 4-3 Typical Rooftop Down Airflow Application with Frame

After the unit is installed, there should be no open passages through the supporting structure that would permit flame or hot gases from a fire originating in the space below the supporting structure to travel to the space above that structure.

NOTICE

A unit with electric heaters with an inlet or outlet duct that penetrates the building structure supporting the unit shall be provided with a mounting base of noncombustible material so designed that, after the unit is installed, there will be no open passages through the supporting structure that would permit flame or hot gases from a fire originating in the space below the supporting structure to travel to the space above that structure. If the unit is intended to be installed on a supporting structure of combustible material, the base shall be so designed that the required clearance will be maintained between the supporting unit mounting base, and shall extend not less than 76 mm (3 in) below the upper surface of the supporting structure, except that, in a unit designed for use only in a mobile home, the distance shall be not less than 19 mm (3/4 in).

5 CONDENSATE DRAIN CONNECTION

Consult local codes for special requirements. To provide extra protection from water damage, install an additional drain pan, provided by installer, under the entire unit with a separate drain line. Manufacturer will not be responsible for any damages due to the failure to follow these requirements.

5.1 Install Drain Pipe

1. Use the provided female NPT threaded fitting for outside connection and make sure that drain holes are not blocked.
2. Insulation may be needed for drain line to prevent sweating.
3. Use a sealing compound on male pipe threads. Install the condensate drain line (NPT) to spill into an open drain.
4. Ensure a trap is included in the condensate drain line.
5. Make sure that the outlet of the trap is at least 1 in. (25 mm) lower than the drain pan condensate connection to prevent the pan from overflowing (See Fig. 5-1).
6. Unit must be slightly inclined toward drain connection.(See Fig. 2-10).

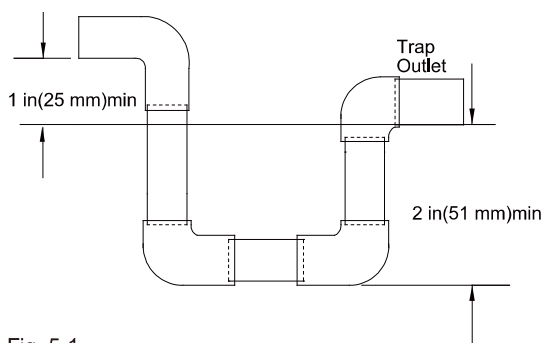

Fig. 5-1

5.2 Removal and Clean The Drain Pan

See above Fig.5-1, disconnect the Connective Tube and Drain Commutator, screw off the two fixed screws of Drain Pan, and then along with the rail pull out the Drain Pan and Connective Tube from the bottom of evaporator. Using a wet cloth or water to wash out the drain pan carefully.

6 ABOUT THE AIR FILTER

6.1 Air Filter (Not Factory-Installed)

Regular cleaning is required for air filters according to the manufacturer's specifications.

External filter or other means of filtration is required. Units should be sized for a maximum of 300 feet/min air velocity or what is recommended for the type of filter installed.

Filter application and placement are critical to airflow, which may affect the heating and cooling system performance. Reduced airflow can shorten the life of the system's major components, such as motor, limits, elements, heat relays, evaporator coil or compressor. Consequently, we recommend that the return air duct system have only one filter location. For systems with a return air filter grill or multiple filter grills, can have a filter installed at each of the return air openings.

If adding high efficiency filters or electronic air filtration systems, it is very important that the air flow is not reduced. If air flow is reduced the overall performance and efficiency of the unit will be reduced. It is strongly recommended that a professional installation technician is contacted to ensure installation of these such filtration systems are installed correctly.

IMPORTANT: Do not double filter the return air duct system. Do not filter the supply air duct system. This will change the performance of the unit and reduce airflow.

⚠ WARNING

Do not operate the system without filters. A portion of the dust entrained in the air may temporarily lodge in the duct and run at the supply registers. Any circulated dust particles could be heated and charred by contact with the air handler elements. This residue could soil ceilings, walls, drapes, carpets and other articles in the house. Soot damage may occur with filters in place, when certain types of candles, oil lamps or standing pilots are burned.

NOTICE

The air filter must conform with the UL 900 Standard.

AIR FILTER REMOVAL

1. Remove bolts manually, remove air filter recover.
2. Hold the edge of the air filter and extract out.
3. Clean the air filter.
4. Install new filter so that the arrow on the filter is in the same direction as airflow.

Units are shipped without a filter or filter racks. It is the responsibility of the installer to secure a filter in the return air ductwork or install a filter/frame Kit.

Filter must always be used and must be kept clean.

When filter become dirt laden, insufficient air will be delivered by the blower, decreasing your units efficiency and increasing operation costs and wear-and tear on the unit and controls.

Filters should be checked monthly; this is especially important since this unit is used for both heating and cooling.

7 ELECTRICAL - LOW VOLTAGE

In the U.S.A., wiring must conform with current local codes and the current National Electric Code (NEC). In Canada, wiring must conform with current local codes and the current Canadian Electrical Code (CEC).

⚠ WARNING

Installation and servicing of air conditioning equipment can be hazardous due to internal refrigerant pressure and live electrical components.

Only trained and qualified service personnel should install or service this equipment. Installation and service performed by unqualified persons can result in property damage, personal injury, or death.

Risk of electrical shock. Disconnect all remote power supplies before installing or servicing any portion of the system. Failure to disconnect power supplies can result in property damage, personal injury, or death.

⚠ CAUTION

The connectors of conventional 24VAC non-communicating control wires must be connected reliably and protected by insulation. The wires unused should be insulated, and the copper wires should not be exposed. Sharp metal edges can cause injury. When installing the unit, use care to avoid sharp edges. Avoid sharp metal edges for wires to prevent wear, or it may lead to short circuit or electric leakage and cause danger.

NOTICE

Electrostatic discharge can affect electronic components. Take care during unit installation and service to protect the unit's electronic controls. Precautions will help to avoid control exposure to electrostatic discharge by putting the unit, the control and the technician at the same electrostatic potential. Touch hand and all tools on an unpainted unit surface before performing any service procedure to neutralize electrostatic charge.

Do not connect the power cords (high voltage) to conventional 24VAC non-communicating control wires (low voltage), otherwise it will damage the control board.

Tighten the zip tie after connecting the wires to prevent small animals from entering the electric control box and causing damage.

The conventional 24VAC non-communicating control wires should be fixed well. Otherwise, the connectors may be loose or the terminal may be damaged when they are pulled.

Before proceeding with electrical connections, make certain that voltage, frequency, and phase correspond to that specified on rating plate. Also, check to be sure that the service provided by utility is sufficient to handle additional load imposed by this equipment.

Please connect the wire following the wiring diagram. The rating power of the transformer is limited. If you connect some additional loads/parts such as zoning panel to it, it may cause component damage. Consult with a professional service people when connecting additional loads/parts to transformer.

All units shipped from factory are wired for 240VAC transformer operation. If the input voltage is 208 V, please change the transformer tap by taking the red wire to 208VAC terminal.

The holes on the side of the machine from top to bottom correspond to electric auxiliary heating entry, power entry, and control entry, respectively.

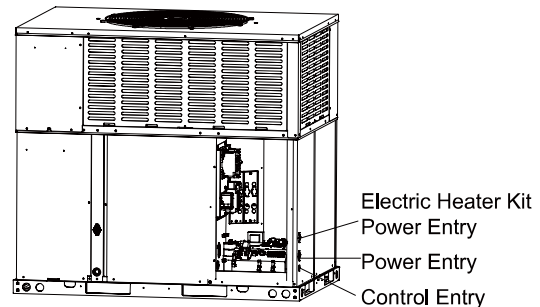

Fig. 7-1

7.1 Low voltage wires maximum length

Table 7-1 defines the maximum total length of low voltage wires from the outdoor unit to the indoor unit and the indoor unit to the thermostat.

Conventional 24VAC Non-communicating Control Wires	
Wires Size	Max Wires Length
18 AWG	150 ft.
16 AWG	225 ft.

Table 7-1

7.2 Low voltage wires connections

The following are guidelines for connecting a 24V conventional non-communication thermostat to an appliance.

1. Remove the electrical control box panel.

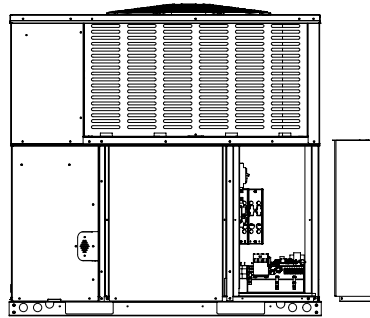

Fig. 7-2

2. Conventional 24 VAC non-communicating thermostat control wires connections.

2.1 Thread the signal wires of the thermostat through the bottom hole and connect the signal wires one by one to the terminal block

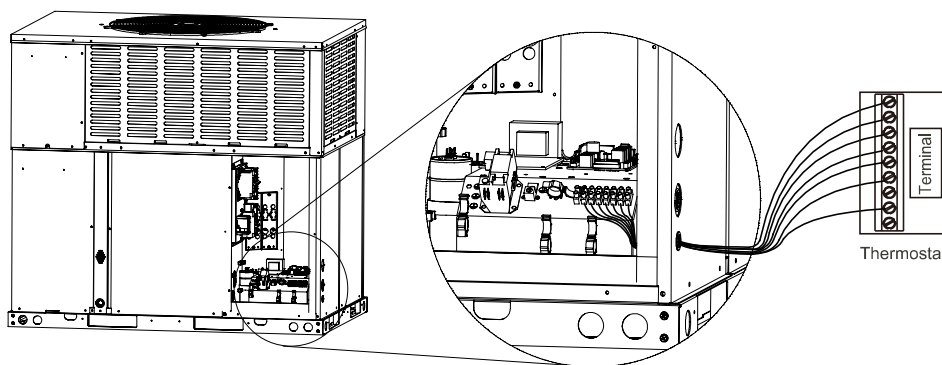

Fig. 7-3

2.2 Confirm that each signal wires is properly connected and tighten the wire socket screws

2.3 Wiring diagram for conventional 24 VAC non-communicating control.

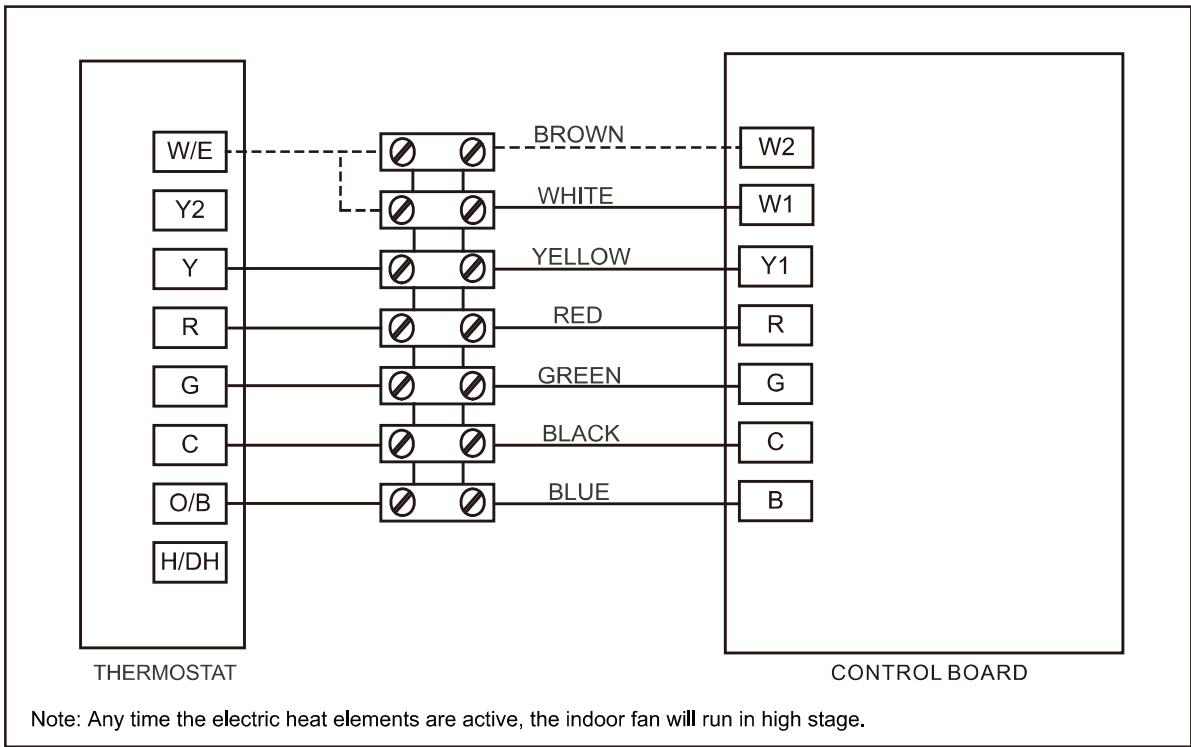

Fig. 7-4 2H and 1C Thermostat Non-communicating Control Mode Setup

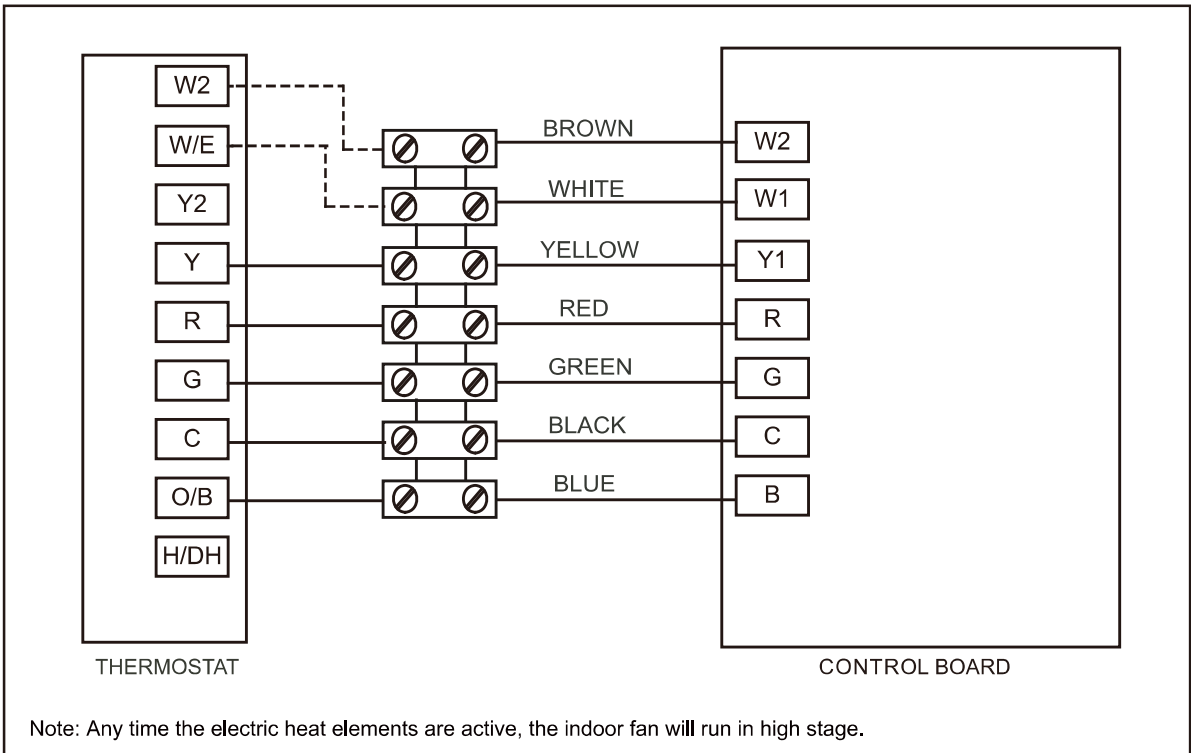

Fig. 7-5 3H and 1C Thermostat Non-communicating Control Mode Setup

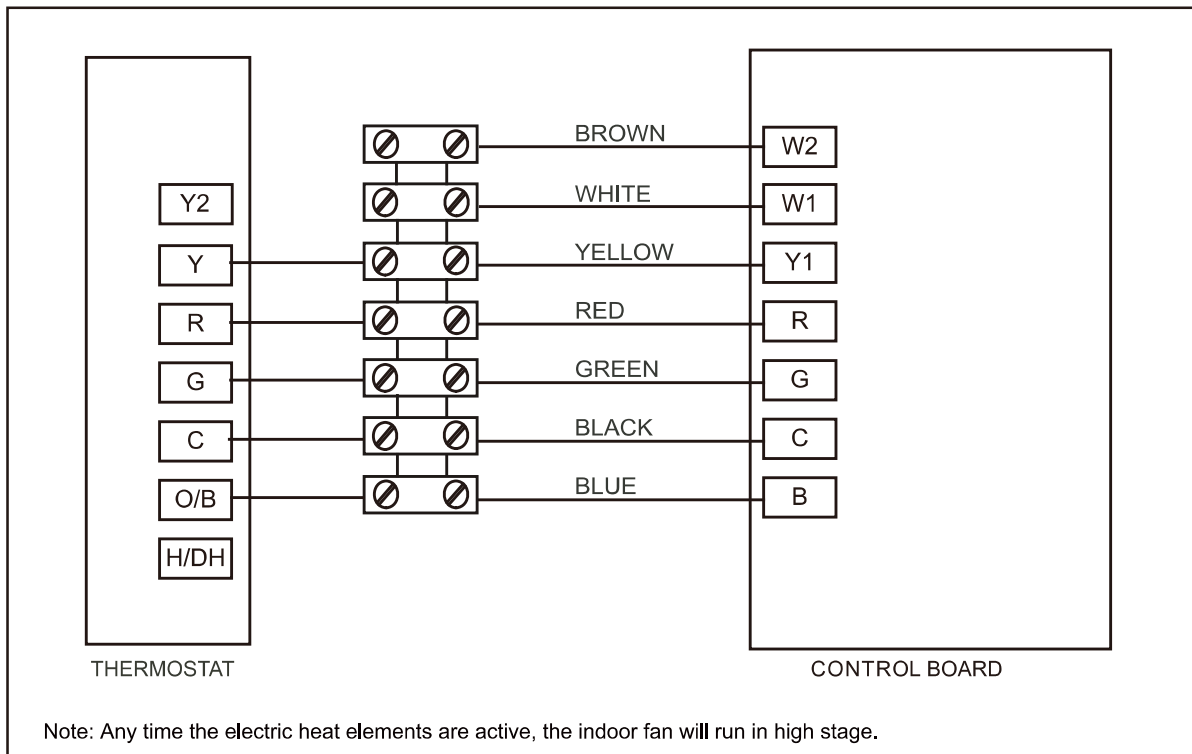

Fig. 7-6 1H and 1C Thermostat Non-communicating Control Mode Setup

NOTICE

Do not interconnect different communication wires or conventional 24VAC non-communicating control wires (CBYW, etc.), otherwise it will damage the control board.

The above pictures are for indication, the actual object may be different.

8 ELECTRICAL – HIGH VOLTAGE

In the U.S.A., wiring must conform with current local codes and the current National Electric Code (NEC). In Canada, wiring must conform with current local codes and the current Canadian Electrical Code (CEC).

⚠ WARNING

Installation and servicing of air conditioning equipment can be hazardous due to internal refrigerant pressure and live electrical components. Only trained and qualified service personnel should install or service this equipment. Installation and service performed by unqualified persons can result in property damage, personal injury, or death.

Risk of electrical shock. Disconnect all remote power supplies before installing or servicing any portion of the system. Failure to disconnect power supplies can result in property damage, personal injury, or death.

Fire Hazard. Use of aluminum wire with this product may result in a fire, causing property damage, severe injury or death. Use copper wire only with this product.

Can cause injury or death. Unit must be properly earthed in accordance with national and local codes.

Natural earthing poles embedded in the earth can be used, but do not connect the earth wire to the following locations:

- (a) Pipes of flammable or explosive gases, which may lead to an explosion or fire.
- (b) Insulated plastic pipes, otherwise there is no earthing effect.
- (c) Telephone line or lightning rod, otherwise it will be dangerous for increasing the earth potential during lightning strikes.

During installation, testing, servicing, and troubleshooting of this product, it may be necessary to work with live electrical components. Failure to follow all electrical safety precautions when exposed to live electrical components could result in death or serious injury.

⚠ CAUTION

Sharp metal edges can cause injury. When installing the unit, use care to avoid sharp edges.

Avoid sharp metal edges for wires to prevent wear, or it may lead to short circuit or electric leakage and cause danger.

Wires should be fixed well. Otherwise, the connectors may be loose or the terminal may be damaged when they are pulled.

NOTICE

Electrostatic discharge can affect electronic components. Take care during unit installation and service to protect the unit's electronic controls. Precautions will help to avoid control exposure to electrostatic discharge by putting the unit, the control and the technician at the same electrostatic potential. Touch hand and all tools on an unpainted unit surface before performing any service procedure to neutralize electrostatic charge.

Do not add phase junction capacitors, otherwise it may cause serious damage to the product.

Do not start the unit before installing pipes. Otherwise, the compressor will be damaged.

The holes on the side of the machine from top to bottom correspond to electric auxiliary heating entry, power entry, and control entry, respectively.

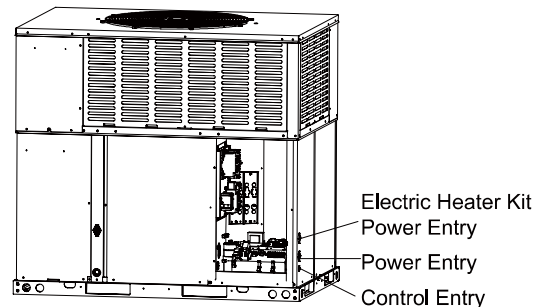

Fig. 8-1

8.1 High Voltage Power Supply

The high voltage power supply must match the equipment nameplate.

Single phase power supply(208/230 V~, 1 PH, 60 Hz)

Three phase power supply(208-230 V~, 3 PH, 60 Hz).

8.2 High Voltage Wires Sizes, Disconnect Switch and Breaker

Refer to the unit nameplate for minimum circuit ampacity, and maximum fuse or circuit breaker (HACR TYPE per NEC). Install power cords and properly sized disconnect switch and breaker.

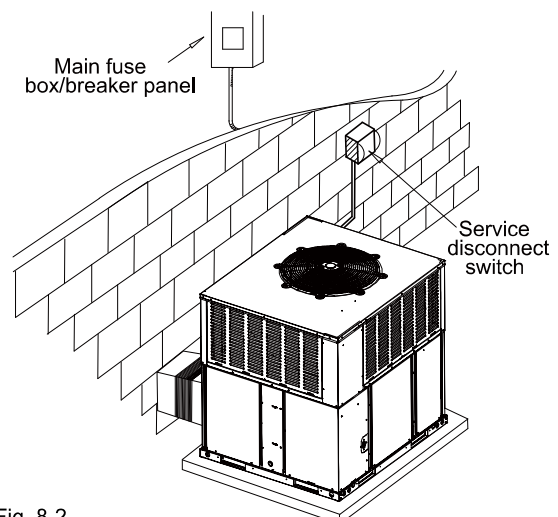

Fig. 8-2

8.3 High Voltage Wires Connections

1. Remove the electrical control box panel. Refer to Fig. 8-3.

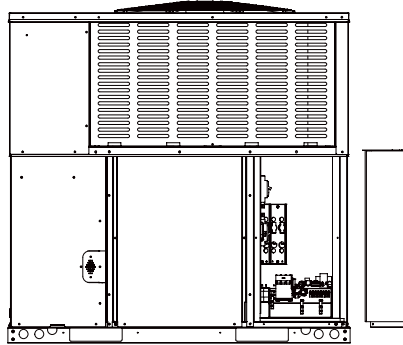

Fig. 8-3

2. Confirm that the hole position of the sheet metal opening corresponds to the wiring function harness.

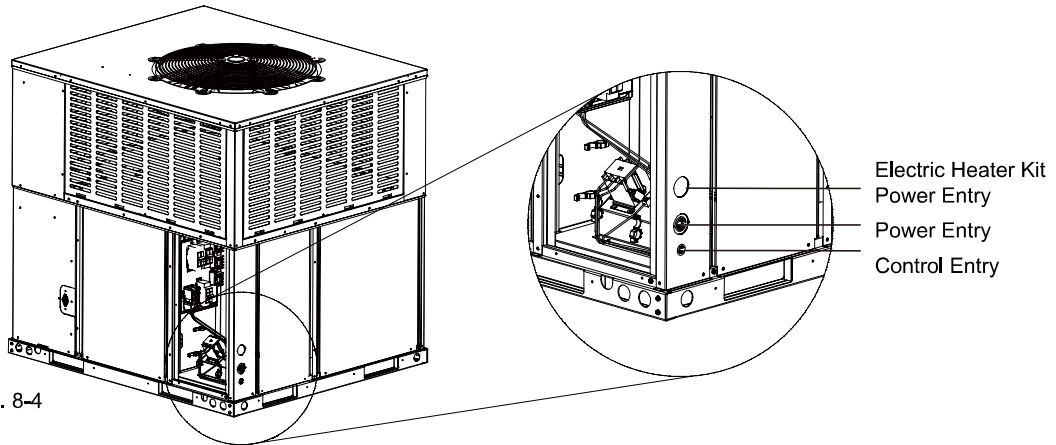

Fig. 8-4

3. Firstly thread the power cords (L1, L2 or L1,L2,L3) and earth wire through the power cords hole. Secondly connect power cords and earth wire to terminals of the power socket properly one by one. Finally fasten the pipe of the power cords and earth wire.

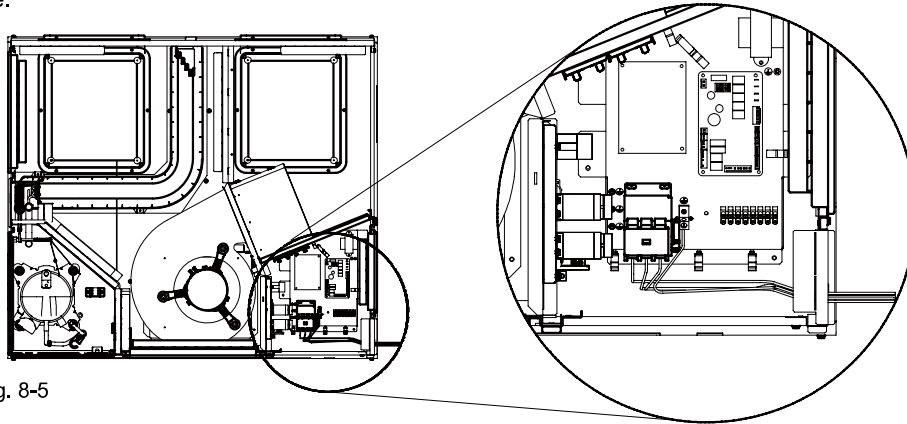

Fig. 8-5

4. Ensure the fasteners are appropriately tightened. Table 8-1 shows torque values for fasteners.

Fastener	Torque
Sheet Metal Screws	10 in · lb
Power Cords Terminal Block Screws	17 in · lb

Table 8-1

NOTICE

Refer to the unit wiring diagram located on the inside of the electrical control box panel.

During installation, the earth wire should be longer than the power cords to ensure that the earth wire can be earthed reliably when the fixed device is loose.

The above pictures are for indication, the actual object may be different.

9 ELECTRIC HEATER KIT

9.1 Electric Heater Kit Breaker Information

NO.	Kit	Description	Breaker	Ref. Air Handler Use
1	EHK-05*	5 kW Heater	30 A	24,30,36,42,48,60
2	EHK-08*	7.5 kW Heater	50 A	24,30,36,42,48,60
3	EHK-10*	10 kW Heater	60 A	24,30,36,42,48,60
4	EHK-15*	15 kW Heater, double Breaker panel	60 A + 30 A	36,42,48,60
5	EHK-20*	20 kW Heater, double Breaker panel	60 A + 60 A	42,48,60

Table 9-1

Note: Heater model number digits "*" : J.

9.2 Electric Heater Kit Install Information

Requirements

Installation of electric heat sections must conform with standard in National Fire Protection Association (NFPA) Standard for Installation of Air Conditioning and Ventilation Systems NFPA No. 90 A, Standard for the Installation of Residence Type Warm Air Heating and Air Conditioning System NFPA No. 90 B, manufacturer's installation instructions and local municipal building codes. Heaters are approved for clearance to combustibles as listed on heater rating plate. Accessibility and service clearances must take precedence over fire protection clearances. All wiring must conform with local codes and the National Electric Code (NEC), ANSI-C1-1978.

⚠ CAUTION

As with any mechanical equipment, contact with sharp sheet metal edges can result in personal injury. Take care while handling this equipment and wear gloves and protective clothing.

The circuit breaker of electric heater kit in indoor unit cannot be used as air switch for power cables and cannot be operated by users. Maintenance personnel need to disconnect the main switch before servicing.

If install a third-party electric heater kit, ensure that all components used of the electric heater kit meet the A2L class flammable refrigerant regulations.

Installation

⚠ WARNING

Supply circuit power wiring must be 167 °F (75 °C) minimum copper conductors only. See Table 9-2 for Electrical Data in this section for ampacity, wire size and circuit protector requirement. Supply circuit protective devices may be either fuses or "HACR" type circuit breakers.

Finished view (for reference only).

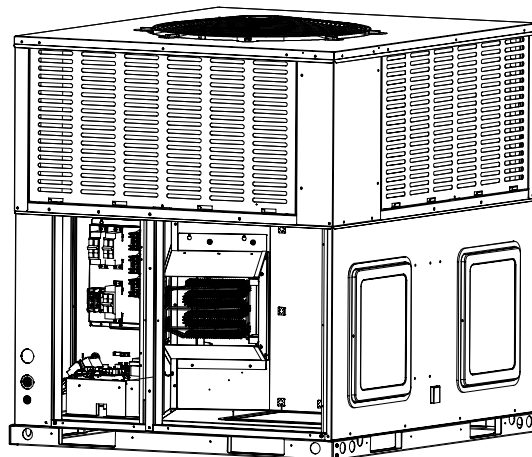

Fig. 9-1

Please refer to the manual of electric heater kit for detailed installation and wiring instructions.

9.3 Electric Heater Kit Electrical Data

Heater Kit Model Used	Air Handler Model	Electric Heat (kW)	Min. Circuit Ampacity		Max. Fuse or Breaker (HACR) Ampacity		Minimum Heating Blower Speed		
			240 V	208 V	240 V	208 V	Low	Middle	High
EHK-05*	24	5	26	23	30	25	●	●	●
EHK-08*		7.5	40	34	40	35	X	●	●
EHK-10*		10	53	46	60	50	X	●	●
EHK-05*	30	5	26	23	30	25	●	●	●
EHK-08*		7.5	40	34	40	35	●	●	●
EHK-10*		10	53	46	60	50	X	●	●
EHK-15*	36	15	79	68	80	70	X	●	●
EHK-05*		5	26	23	30	25	●	●	●
EHK-08*		7.5	40	34	40	35	●	●	●
EHK-10*	42	10	53	46	60	50	X	●	●
EHK-15*		15	79	68	80	70	X	●	●
EHK-20*		20	105	91	110	100	X	X	●
EHK-05*	48	5	26	23	30	25	●	●	●
EHK-08*		7.5	40	34	40	35	●	●	●
EHK-10*		10	53	46	60	50	●	●	●
EHK-15*	60 (208/230 V~ 60 Hz)	15	79	68	80	70	X	●	●
EHK-20*		20	105	91	110	100	X	X	●
EHK-05*		5	26	23	30	25	●	●	●
EHK-08*	60 (208/230 V 3~ 60 Hz)	7.5	40	34	40	35	●	●	●
EHK-10*		10	53	46	60	50	●	●	●
EHK-15*		15	79	68	80	70	X	●	●
EHK-20*	60 (208/230 V 3~ 60 Hz)	20	105	91	110	100	X	X	●
EHK-05*		5	26	23	30	25	●	●	●
EHK-08*		7.5	40	34	40	35	●	●	●
EHK-10*	60 (208/230 V 3~ 60 Hz)	10	53	46	60	50	●	●	●
EHK-15*		15	79	68	80	70	X	●	●
EHK-20*		20	105	91	110	100	X	X	●

Table 9-2

Note: Heater model number digits "***" : J.

10 SETTING

10.1 Setting the Indoor Unit

Check whether the DIP switch is correct according to the wiring nameplate after the electrical wiring is complete. SW6-1,2 is used to set the blower speed. The factory default settings of different models as shown in the Table 10-1 and 10-2.

Table 10-1 applies to 2.5 Ton/3 Ton/3.5 Ton/5 Ton models, and Table 10-2 applies to 2 Ton/4 Ton models. The DIP switch can be adjusted according to different speed requirements. The blower speed of cooling operation and heating operation is same. When there is G or Y1 signal, the blower running at lower speed, when there is W/W1/W2 signal, running at high speed.







	DIP Switch	Y1 or G	W/W1/W2
SW6-1,2 Fan Speed Taps		2	3
	 30K/42K	3	4
		4	5
	 36K/60K	5	5
SW6-3	ON	Anti-cool air	
	OFF	Non-anti-cool air*	
Reserved			
SW6-4		The Factory Default*	
SW7-1,2 SW7-3,4		The Factory Default*	

Table 10-1





	Model	DIP Switch	G	W/W1/W2
SW6-1,2 Fan Speed Taps	48K		L	H
			L	H
	24K		M	H
			H	H
Reserved				
SW6-3,4			Factory default	

Table 10-2

Note: * means the factory default.

10.2 Setting the Outdoor Unit

Check whether the DIP switch is correct according to the wiring nameplate after the electrical wiring is complete. SW3-1 is used to set the manual defrost, When SW3-1 is switched from OFF to ON, the appliance will automatically enter defrosting; SW3-2 is used to set the defrosting action, When SW3-2 is dialled to the ON position, the defrosting process compressor will stop. When SW3-2 is dialled to the OFF position, the defrosting process compressor will not stop (5Ton three-phase model SW3-2=ON, other models SW3-2=OFF).

SW3-3 is used to set the defrosting period. When SW3-3 is dialled to the ON position, the defrosting period is 30min. When SW3-3 is dialled to the OFF position, the defrosting period is 60min. Table 10-3 shows the specific DIP switch Settings.

SW3-1	ON	Manual Defrost
	OFF	Automatic Defrost*
SW3-2	ON	Single-phase Unit
	OFF	Three-phase Unit
SW3-3	ON	Defrosting Cycle: 30min
	OFF	Defrosting Cycle: 60min*

Table 10-3

Note: * means the factory default. The SW3-2 factory default dip switch is set to ON for single-phase models and OFF for three-phase models.

11 START UP

11.1 System Start Up

1. Ensure Sections 2, 3, 4, 5, 6, 7, 8, 9 have been completed. Check the electrical wiring again, and check whether the DIP switch meets the requirements according to the wiring diagram on the electrical control box panel.
2. Set System Thermostat to OFF.



Fig. 11-1

3. Check voltage supply at the disconnect switch. The voltage must be within the range listed on the unit nameplate. If not, do not start appliance until the power company has been consulted and the voltage condition corrected. Turn on disconnect to apply power to the indoor and outdoor units.

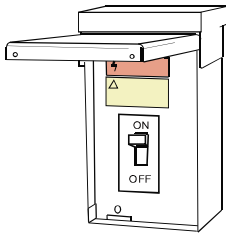

Fig. 11-2

4. Upon initial unit installation, wait one (1) hour before starting the unit if compressor crankcase heater is used and the outdoor ambient temperature is below 70 °F.



Fig. 11-3

5. Set system thermostat to ON.



Fig. 11-4

6. Recheck unit voltage with unit running. Power must be within range shown on unit nameplate.

7. OPERATION CHECK-UP

• Cooling Startup

Set system thermostat to COOL and thermostat temperature setting below room temperature. Unit should run in COOLING mode.

• Heating Startup

After normal cooling run.

1. Turn thermostat switch to HEAT. After unit stops, wait about 5 minutes.
2. Turn thermostat setting above room temperature. Unit should run in HEATING mode.

After unit has run for a while, check the following:

1. Are fans running properly?
2. Is compressor running correctly?
3. Check refrigerant charge.
4. Check duct connection for leaks.
5. Check for tubing and sheet metal rattles.

11.2 External Static Pressure Setup

To measure external static pressure:

1. Measure the supply air static pressure and record this positive number.
2. Measure the return air static pressure and record this negative number.
3. Treat the negative number as a positive and add the two numbers together. This is total system static.

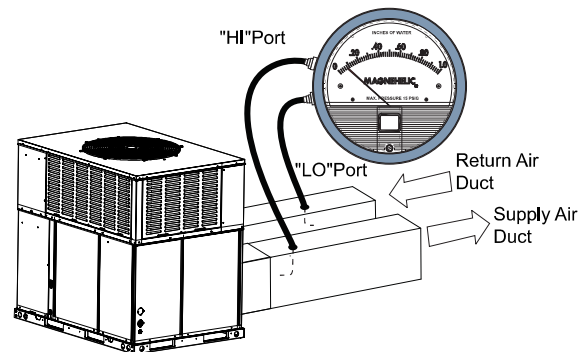

Fig. 11-5 Measuring External Static Pressure

12 SYSTEM OPERATION

12.1 Compressor Crankcase Heater (Optional)

Refrigerant migration during the off cycle can result in a noisy start up. Add a crankcase heater to minimize refrigeration migration, and to help eliminate any start up noise or bearing “wash out”.

All heaters are located on the lower half of the compressor shell. Its purpose is to drive refrigerant from the compressor shell during long off cycles, thus preventing damage to the compressor during start-up.

At initial start-up or after extended shutdown periods, make sure the heater is energized for at least 12 hours before the compressor is started. (Disconnect switch on and wall thermostat off.)

The crankcase heater will start up or shut down according to the following logic:

The crankcase heater will start up when the compressor is off and $T4 < 41\text{ }^{\circ}\text{F}$.

The crankcase heater will shut down when $T4 \geq 44.6\text{ }^{\circ}\text{F}$.

In any condition, the crankcase heater will shut down when the compressor is on

12.2 Reversing Valve Operation

Reversing valve energizes during heat mode and de-energizes in cooling mode. The input voltage is 24 V.

12.3 Protection

12.3.1 Protection for HP system If sensors (T3&T4)

Discharge temperature protection

If discharge temp. is $> 257\text{ }^{\circ}\text{F}(4T\setminus 5T)$, the compressor will shut down. If discharge temp. is $< 203\text{ }^{\circ}\text{F}(4T\setminus 5T)$, the compressor will resume operation.

If discharge temp. is $> 239\text{ }^{\circ}\text{F}(2T\setminus 2.5T\setminus 3T\setminus 3.5T)$, the compressor will shut down. If discharge temp. is $< 167\text{ }^{\circ}\text{F}(2T\setminus 2.5T\setminus 3T\setminus 3.5T)$, the compressor will resume operation.

High pressure protection

If high pressure is $> 580\text{ psig}$, the compressor and the outdoor fan motor will stop running.

If high pressure is $< 435\text{ psig}$, the compressor and the outdoor fan motor will resume running(3 minutes delay necessary).

Outdoor coil temperature protection (T3)

If $T3 > 150.8\text{ }^{\circ}\text{F}$, compressor is de-energized

If $T3 < 125.6\text{ }^{\circ}\text{F}$, compressor is energized.

Low pressure protection

When low pressure is $< 15\text{ psig}$, the compressor and the outdoor fan motor will stop running.

When low pressure is $> 32\text{ psig}$, the compressor and the outdoor fan motor will resume running(3 minutes delay necessary). In stand-by status, if low pressure protection was detected, the compressor will not start.

NOTICE

If protection cycles occur four times within 30 minutes, the compressor and outdoor fan will shut down. In this condition, the system needs to power on once more in order to keep on working.

T4 function

i. If $50\text{ }^{\circ}\text{F} \leq T4 < 125\text{ }^{\circ}\text{F}$, unit can operate in cooling

ii. If $5\text{ }^{\circ}\text{F} \leq T4 < 77\text{ }^{\circ}\text{F}$, unit can operate in heating

NOTICE

When $T4$ is $< 5\text{ }^{\circ}\text{F}$, the compressor may not start, if compressor not started and the electrical heater kit is installed in the indoor unit, the outdoor unit will send the "W" signal to the indoor unit in order to open the electrical heater. When $T4$ is $> 10.4\text{ }^{\circ}\text{F}$, the compressor will restart.

12.4 Defrost Mode* (For HP System Only)

Manual defrost mode

To manually cycle the defrost mode, set switch SW3-1 to the "ON" position(See Fig. 12-1). The system will engage a defrost cycle, and automatically exit defrost mode once the Shut-down conditions of defrost mode described below are met.

CAUTION: Once the manual defrost mode is finished, please set switch SW3-1 back to "OFF".

Start-up conditions of defrost mode:

When SW3-3 switch is set to "ON"(See Fig 12-1), the system will perform a defrost cycle in any of the following conditions:

1. If the compressor is operating and $T3 < 30.2\text{ }^{\circ}\text{F}$, the system will perform a defrost cycle every 30 minutes of operation.
2. When $T3 < 28.4\text{ }^{\circ}\text{F}$ and the compressor is operating for the first time after being connected power.
3. When $T3 < 28.4\text{ }^{\circ}\text{F}$ and The system has been in standby for two hours .



Fig.12-1 SW3 Switch Location in the main control Board (For reference only)

SW3	SW3-1	ON	Manual Defrost
		SW3-2	OFF
	SW3-2	ON	Single-phase Unit
	SW3-2	OFF	Three-phase Unit
	SW3-3	ON	Defrosting Cycle: 60min
	SW3-3	OFF	Defrosting Cycle: 30min

When SW3-3 switch is set to "OFF"(See in Fig. 12-1), the system will perform a defrost cycle in any of the following conditions:

1. If the compressor is operating and T3 is < 30.2 °F, the system will perform a defrost cycle every 60 minutes of operation.
2. When T3 is < 28.4 °F and the compressor is operating for the first time after being connected power.
3. When T3 is < 28.4 °F and the system has been in standby for two hours.

Shut-down conditions of defrost mode:

The mode will shut down in any of the following conditions:

1. The defrosted time lasting for 10 minutes;
2. T3 is ≥ 77 °F when T4 ≥ 28.4 °F;
3. Compressor stop operating;
4. T3 is ≥ 77 °F last for 60s when T4 < 28.4 °F.

12.5 Thermostat Signals

Table 12-1: Thermostat Signals

Signal	State	Board Function
G	ON	Blower instant ON
	OFF	Blower 90 s. delay OFF
G & W1	ON	Blower instant ON Heater bank 1 elec.onstant ON
	OFF	Heater bank 1 elec.instant OFF Blower 90 s. delay OFF
G & W & W2	ON	Blower instant ON Heater 1 instant ON Heater 2 instant ON
	OFF	Blower 90 s. delay OFF Heater 1 instant OFF Heater 2 instant OFF
G & Y	ON	Blower instant ON Compressor and outdoor fan instant ON
	OFF	Compressor and outdoor fan instant OFF Blower fan delay 90 s. OFF
G & B & Y	ON	Blower instant ON Compressor and outdoor fan instant ON 4-way valve instant ON
	OFF	Compressor and outdoor fan instant OFF Blower fan delay 90 s. OFF 4-way valve instant OFF
G & B & Y & W1	ON	Blower instant ON Compressor and outdoor fan instant ON 4-way valve instant ON Heater 1 instant ON
	OFF	Blower fan delay 90 s. OFF Compressor and outdoor fan instant OFF 4-way valve instant OFF Heater 1 instant OFF
G & B & Y & W1 & W2	ON	Blower instant ON Compressor and outdoor fan instant ON 4-way valve instant ON Heater 1 instant ON Heater 2 instant ON
	OFF	Blower fan delay 90 s. OFF Compressor and outdoor fan instant OFF 4-way valve instant OFF Heater 1 instant OFF Heater 2 instant OFF

13 SERVICE AND MAINTENANCE

13.1 Error Code and Troubleshooting

The unit has two main control boards for indoor unit and outdoor unit. The unit LED will flash when the unit is abnormal. Security consideration, the unit shutdown until the abnormal condition is corrected.

CONTROL BOARD 1		
LED Status	Description	Possible Reason
1Flash/Cycle	T3 sensor fault	T3 sensor is short circuit or open circuit
2Flash/Cycle	T4 sensor fault	T4 sensor is short circuit or open circuit/Poor heat exchange on condensing side/refrigerant over charge/throttle blocked
3Flash/Cycle	Low pressure cut-out protection	Poor heat exchange on evaporation side/Charging leakage (low refrigerant)/throttle blocked
4Flash/Cycle	Power phase fault	The phase sequence of the power cable is incorrect/wiring error
5Flash/Cycle	Condensor coil temperature protection in cooling(T3)	High temperature and overload/poor heat exchange on condensing side/T3 failure
6Flash/Cycle	Ambient temperature limited(T4)	Ambient temperature is out of the range/There are other heat sources around T4
CONTROL BOARD 2		
LED Status	Description	Possible Reason
3Flash/Cycle	R454B refrigerant sensor fault	R454B refrigerant sensor failure
4Flash/Cycle	R454B refrigerant sensor communication fault	Wiring error/ R454B refrigerant sensor failure
Keep Flashing	R454B refrigerant leakage protection in indoor unit	R454B refrigerant leakage/R454B refrigerant sensor failure
8Flash/Cycle	R454B refrigerant sensor over service life	R454B refrigerant sensor over service life/R454B refrigerant sensor failure

Table 13-1

NOTICE

The control board 1 flash interval is 3 seconds. For example, 3 Flash / Cycle is flash three times every 3 seconds. The control board 2 flash interval is 2 seconds. For example, 3 Flash / Cycle is flash three times every 2 seconds.

Within 10 seconds after power-on, the LED light flashes to display the software version number and then displays normally. The display mode of the software version is as follows:

1. The LED light is off within 2 seconds of power-on;
2. After the system is powered on for 2 seconds, the LED light flashes the units digit of the version number, then the tens digit, and pauses for 2 seconds between the units digit and the tens digit. (If the tens place is 0, the ones place is displayed and then extinguished);
3. The LED light displays normally 10 seconds after power-on.

When the outdoor temperature is between 50 °F and 67 °F, the compressor can only run for cooling within a short time, otherwise it may cause damage to compressor.

⚠ CAUTION

If the refrigerant sensor over service life, should be replaced by an authorized person.

If a leak is detected, follow safety procedures: Immediately evacuate all persons from the room or space, and contact the qualified licensed service personnel to advise them that the refrigerant R454B (A2L class flammable refrigerant) leak has occurred.

⚠ WARNING

Component trouble shooting requires opening control box with power on. Use extreme care while working on this condition. Check nameplate and this instruction when making wire connections.

13.2 Illustration for Covering Side Openings for Downflow Application

FOAM STICKED METHOD:

1. Use two covers from bottom openings to cover the side openings.
2. Use four sticking foam tapes provided in accessory bag and stick tapes on covers. See Fig.13-1 and Fig.13-2.
3. Place the covers on supply and return openings and use screws and washers provided to hold covers. See Fig.13-3.
4. Use silicon sealant to seal four sides of covers to prevent water from coming into equipment.

Foam tape

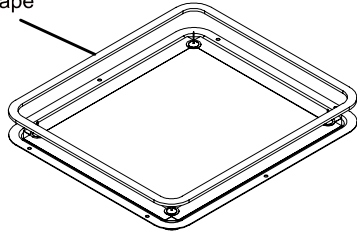

Fig.13-1

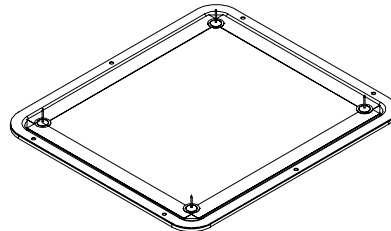

Fig.13-2

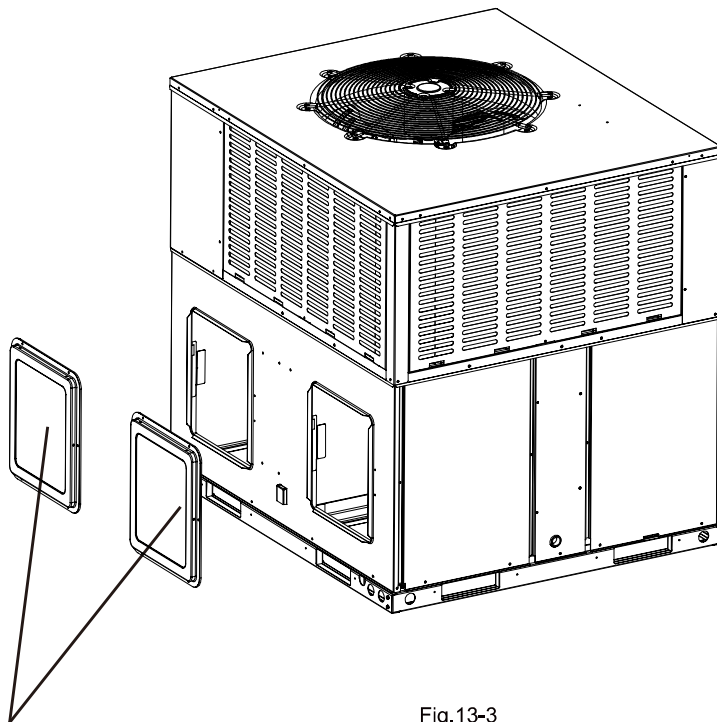

Fig.13-3

Return/Supply duct cover
(attach with 4 screws)

13.3 Care and Maintenance

13.3.1 Cleaning Precautions

⚠ CAUTION

- Any maintenance and cleaning of outdoor unit must be performed by qualified service personnel only.
- Any unit repairs must be performed by qualified service personnel only.

⚠ CAUTION

Always turn off our heat pump and disconnect its power supply before cleaning or maintenance.

- Do not use chemicals or chemically treated cloths to clean the unit.
- Do not use benzene, paint thinner, polishing powder or other solvents to clean the unit.

13.3.2 Changing Your Air Filter

⚠ CAUTION

- Before changing the filter or cleaning, turn off the unit and disconnect its power supply.
- When removing filter, do not touch metal parts in the unit. The sharp metal edges can cut you.

A clogged air conditioner can reduce the cooling efficiency of your unit, and can also be bad for your health. Make sure to change the filter every 3 months.

13.3.3 Maintenance – Long Periods of Non-Use

If you plan not to use your air conditioner for an extended period of time, do the following:

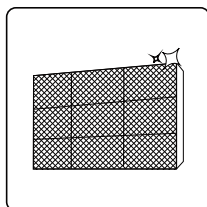

Change all filters

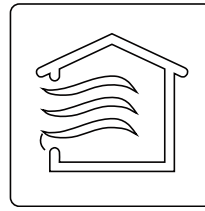

Turn on FAN function until unit dries out completely

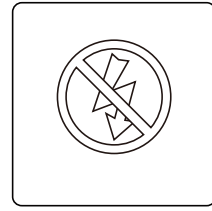

Turn off the unit and disconnect the power

Fig. 13-4

13.3.4 Maintenance – Pre-Season Inspection

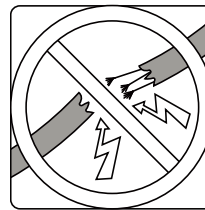

Check for damaged wires



Check for leaks

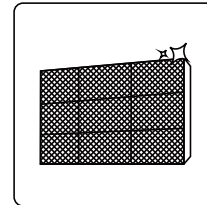

Verify all filters have been replaced and are new



Make sure nothing is blocking all air inlets and outlets

Fig. 13-5

14 DISPOSAL

Comply with national regulations.

Components and accessories from the units are not part of ordinary domestic waste.

Complete units, compressors, motors etc. are only to be disposed of via qualified disposal specialists.

This unit uses flammable refrigerant R454B. Please contact the dealer when you want to dispose of this unit. Law requires that the collection, transportation and disposal of refrigerants must conform with the regulations governing the collection and destruction of hydrofluorocarbons.

16127700A12565 V1.0