

# ComfortStar®

## INSTALLATION INSTRUCTIONS

### Air Handler Unit

Model Size:

LUC6-18-15(38Q)

LUC6-24-15(38R)

LUC6-30-15(38S)

LUC6-36-15(38T)

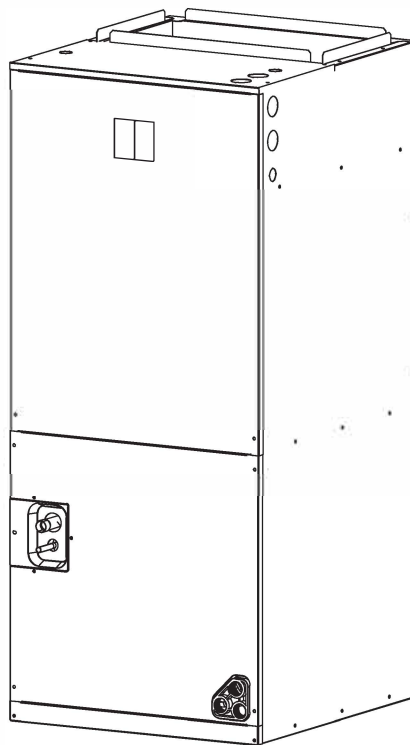

R454B



# CONTENTS





1. Symbol and Key to Safety Instructions.....	01
2. General.....	09
3. Application .....	13
4. Electrical Wiring.....	22
5. Airflow Performance .....	25
6. Ductwork .....	28
7. Refrigerant Pipe Connection .....	29
8. Air Filter (Not Factory Installed).....	32
9. Filter.....	33
10. Maintenance .....	34
11. Wiring Diagram .....	35

# 1. Symbol and Key to Safety Instructions

## 1.1 Symbol Keywords

	<b>WARNING</b>	The warnings in this document are identified by warning triangles printed on a black background. The keyword at the beginning of the warning indicates the type and severity of the risk if no measures are taken to prevent it.
---	----------------	--

The following keywords are defined and used in this document:

	<b>Dangerous</b>	Means a hazardous situation, which, if not avoided, will lead to death or serious injury.
	<b>Warning</b>	Indicates a hazardous situation, which may lead to death or serious injury if not avoided.
	<b>Caution</b>	Indicates a hazardous situation, which may cause mild to moderate injury if not avoided.
	<b>Note</b>	Used to deal with behaviors unrelated to personal injury.

### Important Information

	This symbol represents important information that is not harmful to people or property.
---	---

## 1.2 Safety

Please Read Before Continuing.

### Warning:

- The unit must be installed by qualified personnel with a capability certificated for handling R454B refrigerant. Refer to regulation and laws in use on installation location.
- This appliance is not intended for use by persons (including children) with reduced physical, sensory or mental capabilities, or lack of experience and knowledge, unless they have been given supervision or instruction concerning use of the appliance by a person responsible for their safety.
- The appliance shall be installed in accordance with national wiring regulations.
- Children should be supervised to ensure that they do not play with the appliance.
- The minimum clearance to combustible surfaces (curtains, blinds, etc.) from the appliance should be 300 mm.
- Maximum outlet air temperature with electric heater should be limited to 90°C(194°F).
- Leak detection system installed. Unit must be powered except for service
- Before accessing the connection terminals, all power circuits must be disconnected.
- Please read these instructions carefully before attempting to install or operate. Failure to follow these instructions may result in incorrect installation, adjustment, repair or maintenance, which may result in fire, electric shock, property damage, personal injury or death.
- Installation, service, maintenance and repair of this unit must be performed by a certified technician.
- Servicing shall be performed only as recommended by the manufacturer.
- Product uninstallation and recycling must be performed by a certified technician.
- keep any required ventilation openings clear of obstruction;
- The appliance shall be stored in a well-ventilated area where the room size corresponds to the room area as specified for operation
- The appliance shall be stored in a room without continuously operating open flames (for example an operating gas appliance) and ignition sources (for example an operating electric heater)



### QUALIFICATION OF WORKERS

The installation and servicing of this equipment must be performed by qualified, experienced technicians only. Professional installation personnel should have the following experience:

- Installing the electric heater
- Opening of sealed components
- Opening of ventilated enclosures
- Commissioning and troubleshooting
- Checking the electric control part and wiring
- Breaking into the refrigerant circuit and charging



This document is property of customer and should be kept together with this equipment.

These instructions do not cover all the different variations of the system, nor do they provide all the unexpected situations that may be encountered during the installation process.



The manufacturer recommends installing only approved matched indoor and outdoor systems. Some of the benefits of installing approved matched indoor and outdoor split systems are maximum efficiency, optimum performance and the best overall system reliability.

**Warning: Fire, electric shock, property damage, personal injury or death**



- The whole installation process must comply with NATIONAL, STATE AND LOCAL CODES. If you need more information, please contact your local dealer.
- Dispose of properly in accordance with federal or local regulations. Flammable refrigerant used.
- Risk of fire due to flammable refrigerant used. Follow handling instructions carefully in compliance with national regulations

**Warning: Risk of electric shock**



- Can cause injury or death. Disconnect all remote electric power supplies before servicing. More than one disconnect switch may be required to cut off the power of the equipment. Dangerous voltage can cause serious personal injury or death.

**Warning: Electric shock**



- If the fan assembly needs to be dismantled, all disconnect switches supplying power to the equipment must be powered off and locked (if the device cannot be seen), so that the field power cord can be safely dismantled from the fan assembly. Otherwise, it may cause electric shock, personal injury or death.

**Warning: Fire, electric shock, property damage, personal injury or death**







- Flammable refrigerant used. Consult repair manual/owner's guide before attempting to service this product. All safety precautions must be followed.
- Due to possible equipment damage or personal injury, installation, repair and maintenance should be carried out by trained qualified maintenance personnel. Consumers are advised to only clean/replace the filter screen. Do not operate the equipment with the access panel removed.

**Warning:**



- Do not use means to accelerate the defrosting process or to clean, other than those recommended by the manufacturer.
- The appliance shall be stored in a room without continuously operating ignition sources (for example: open flames, an operating gas appliance or an operating electric heater).
- Do not pierce or burn.
- Be aware that refrigerants may not contain an odour.

	<b>WARNING</b>	This symbol that this appliance used a flammable refrigerant. If the refrigerant is leaked and exposed to an external ignition source, there is a risk of fire.
	<b>CAUTION</b>	This symbol that the operation manual should be read carefully.
	<b>CAUTION</b>	This symbol that a service personnel should be handling this equipment with reference to the installation manual.
	<b>CAUTION</b>	This symbol that information is available such as the operating manual or installation manual.

**Warning:**

- This product may expose you to chemicals including lead and lead components, which are known to cause cancer, birth defects or other reproductive harm in California. For more information, please visit [www.P65Warnings.ca.gov](http://www.P65Warnings.ca.gov).

**Warning: Electric shock**

- The device must be permanently grounded. Otherwise, it will cause electric shock, personal injury or death.

**Note: Fire risk**

- The product is only used for one or two residences.
- The materials of pressure ventilation system and piping system must meet the latest NFPA 90B standard.

**Note:**

- Make sure the fan bracket is fastened (3 motor mounting bolts-Figure1). Then, before operating the device, check whether the wheels are firmly fixed on the motor shaft.

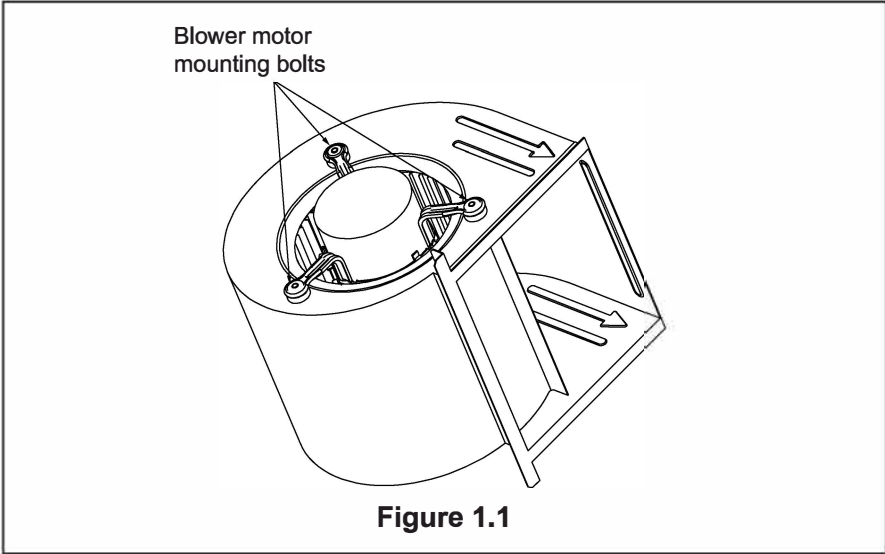

## 1.3 Safety Precautions for R454B Refrigerant



### Warning:

- Do not use means to accelerate the defrosting process or to clean, other than those recommended by the manufacturer.
- The appliance shall be stored in a room without continuously operating ignition sources (for example: open flames, an operating gas appliance or an operating electric heater).
- Do not pierce or burn.
- Be aware that refrigerants may not contain an odour.

### Equipment leak detection

Field-made refrigerant joints indoors shall be tightness tested. The test method shall have a sensitivity of 5 grams per year of refrigerant or better under a pressure of at least 0,25 times the maximum allowable pressure. No leak shall be detected.

### Qualification of workers

Every working procedure like maintenance, service and repair operations that affects safety means shall only be carried out by competent persons.

Examples for such working procedures are:

- breaking into the refrigerating circuit;
- opening of sealed components;
- opening of ventilated enclosures.

### Checks to the area

Prior to beginning work on systems containing FLAMMABLE REFRIGERANTS, safety checks are necessary to ensure that the risk of ignition is minimised.

### Work procedure

Work shall be undertaken under a controlled procedure so as to minimise the risk of a flammable gas or vapour being present while the work is being performed.

### General work area

All maintenance staff and others working in the local area shall be instructed on the nature of work being carried out. Work in confined spaces shall be avoided.

### Checking for presence of refrigerant

The area shall be checked with an appropriate refrigerant detector prior to and during work, to ensure the technician is aware of potentially toxic or flammable atmospheres. Ensure that the leak detection equipment being used is suitable for use with all applicable refrigerants, i.e. non-sparking, adequately sealed or intrinsically safe.

### Presence of fire extinguisher

If any hot work is to be conducted on the refrigerating equipment or any associated parts, appropriate fire extinguishing equipment shall be available to hand. Have a dry powder or CO<sub>2</sub> fire extinguisher adjacent to the charging area.

### No ignition sources

No person carrying out work in relation to a REFRIGERATING SYSTEM which involves exposing any pipe work shall use any sources of ignition in such a manner that it may lead to the risk of fire or explosion. All possible ignition sources, including cigarette smoking, should be kept sufficiently far away from

the site of installation, repairing, removing and disposal, during which refrigerant can possibly be released to the surrounding space. Prior to work taking place, the area around the equipment is to be surveyed to make sure that there are no flammable hazards or ignition risks. "No Smoking" signs shall be displayed.

### **Ventilated area**

Ensure that the area is in the open or that it is adequately ventilated before breaking into the system or conducting any hot work. A degree of ventilation shall continue during the period that the work is carried out. The ventilation should safely disperse any released refrigerant and preferably expel it externally into the atmosphere.

### **Checks to the refrigerating equipment**

Where electrical components are being changed, they shall be fit for the purpose and to the correct specification. At all times the manufacturer's maintenance and service guidelines shall be followed. If in doubt, consult the manufacturer's technical department for assistance.

The following checks shall be applied to installations using FLAMMABLE REFRIGERANTS:

- the actual REFRIGERANT CHARGE is in accordance with the room size within which the refrigerant containing parts are installed;
- the ventilation machinery and outlets are operating adequately and are not obstructed;
- if an indirect refrigerating circuit is being used, the secondary circuit shall be checked for the presence of refrigerant
- marking to the equipment continues to be visible and legible. Markings and signs that are illegible shall be corrected;
- refrigerating pipe or components are installed in a position where they are unlikely to be exposed to any substance which may corrode refrigerant containing components, unless the components are constructed of materials which are inherently resistant to being corroded or are suitably protected against being so corroded.

### **Checks to electrical devices**

Repair and maintenance to electrical components shall include initial safety checks and component inspection procedures. If a fault exists that could compromise safety, then no electrical supply shall be connected to the circuit until it is satisfactorily dealt with. If the fault cannot be corrected immediately but it is necessary to continue operation, an adequate temporary solution shall be used. This shall be reported to the owner of the equipment so all parties are advised. Initial safety checks shall include:

- that capacitors are discharged: this shall be done in a safe manner to avoid possibility of sparking;
- that no live electrical components and wiring are exposed while charging, recovering or purging the system;
- that there is continuity of earth bonding.

### **Repairs to sealed components**

Sealed electrical components shall be replaced.

### **Repair to intrinsically safe components**

Intrinsically safe components must be replaced.

### **Cabling**

Check that cabling will not be subject to wear, corrosion, excessive pressure, vibration, sharp edges or any other adverse environmental effects. The check shall also take into account the effects of aging or continual vibration from sources such as compressors or fans.

### **Detection of flammable refrigerants**

Under no circumstances shall potential sources of ignition be used in the searching for or detection of refrigerant leaks. A halide torch (or any other detector using a naked flame) shall not be used.

The following leak detection methods are deemed acceptable for all refrigerant systems.

Electronic leak detectors may be used to detect refrigerant leaks but, in the case of FLAMMABLE REFRIGERANTS, the sensitivity may not be adequate, or may need re-calibration. (Detection equipment shall be calibrated in a refrigerant-free area.) Ensure that the detector is not a potential source of ignition and is suitable for the refrigerant used. Leak detection equipment shall be set at a percentage of the LFL of the refrigerant and shall be calibrated to the refrigerant employed, and the appropriate percentage of gas (25 % maximum) is confirmed.

Leak detection fluids are also suitable for use with most refrigerants but the use of detergents containing chlorine shall be avoided as the chlorine may react with the refrigerant and corrode the copper pipe-work.

If a leak is suspected, all naked flames shall be removed/extinguished.

If a leakage of refrigerant is found which requires brazing, all of the refrigerant shall be recovered from the system, or isolated (by means of shut off valves) in a part of the system remote from the leak. Removal of refrigerant shall be according to Removal and evacuation.

### **Removal and evacuation**

When breaking into the refrigerant circuit to make repairs – or for any other purpose –conventional procedures shall be used. However, for flammable refrigerants it is important that best practice be followed, since flammability is a consideration. The following procedure shall be adhered to:

- safely remove refrigerant following local and national regulations;
- evacuate;
- purge the circuit with inert gas (optional for A2L);
- evacuate (optional for A2L);
- continuously flush or purge with inert gas when using flame to open circuit; and
- open the circuit.

The refrigerant charge shall be recovered into the correct recovery cylinders if venting is not allowed by local and national codes. For appliances containing flammable refrigerants, the system shall be purged with oxygen-free nitrogen to render the appliance safe for flammable refrigerants. This process might need to be repeated several times. Compressed air or oxygen shall not be used for purging refrigerant systems.

For appliances containing flammable refrigerants, refrigerants purging shall be achieved by breaking the vacuum in the system with oxygen-free nitrogen and continuing to fill until the working pressure is achieved, then venting to atmosphere, and finally pulling down to a vacuum (optional for A2L). This process shall be repeated until no refrigerant is within the system (optional for A2L). When the final oxygen-free nitrogen charge is used, the system shall be vented down to atmospheric pressure to enable work to take place.

The outlet for the vacuum pump shall not be close to any potential ignition sources, and ventilation shall be available.

### **Charging procedures**

In addition to conventional charging procedures, the following requirements shall be followed.

- Ensure that contamination of different refrigerants does not occur when using charging equipment. Hoses or lines shall be as short as possible to minimise the amount of refrigerant contained in them.
- Cylinders shall be kept in an appropriate position according to the instructions.
- Ensure that the REFRIGERATING SYSTEM is earthed prior to charging the system with refrigerant
- Label the system when charging is complete (if not already).
- Extreme care shall be taken not to overfill the REFRIGERATING SYSTEM. Prior to recharging the system, it shall be pressure-tested with the appropriate purging gas. The system shall be leak-tested on completion of charging but prior to commissioning. A follow up leak test shall be carried out prior to leaving the site.

## Decommissioning

Before carrying out this procedure, it is essential that the technician is completely familiar with the equipment and all its detail. It is recommended good practice that all refrigerants are recovered safely. Prior to the task being carried out, an oil and refrigerant sample shall be taken in case analysis is required prior to re-use of recovered refrigerant. It is essential that electrical power is available before the task is commenced.

- a) Become familiar with the equipment and its operation.
- b) Isolate system electrically.
- c) Before attempting the procedure, ensure that:
  - mechanical handling equipment is available, if required, for handling refrigerant cylinders;
  - all personal protective equipment is available and being used correctly;
  - the recovery process is supervised at all times by a competent person;
  - recovery equipment and cylinders conform to the appropriate standards.
- d) Pump down refrigerant system, if possible.
- e) If a vacuum is not possible, make a manifold so that refrigerant can be removed from various parts of the system.
- f) Make sure that cylinder is situated on the scales before recovery takes place.
- g) Start the recovery machine and operate in accordance with instructions.
- h) Do not overfill cylinders (no more than 80 % volume liquid charge).
- i) Do not exceed the maximum working pressure of the cylinder, even temporarily.
- j) When the cylinders have been filled correctly and the process completed, make sure that the cylinders and the equipment are removed from site promptly and all isolation valves on the equipment are closed off.
- k) Recovered refrigerant shall not be charged into another REFRIGERATING SYSTEM unless it has been cleaned and checked

## Labelling

Equipment shall be labelled stating that it has been de-commissioned and emptied of refrigerant. The label shall be dated and signed. For appliances containing FLAMMABLE REFRIGERANTS, ensure that there are labels on the equipment stating the equipment contains FLAMMABLE REFRIGERANT.

## Recovery

When removing refrigerant from a system, either for servicing or decommissioning, it is recommended good practice that all refrigerants are removed safely.

When transferring refrigerant into cylinders, ensure that only appropriate refrigerant recovery cylinders are employed. Ensure that the correct number of cylinders for holding the total system charge is available. All cylinders to be used are designated for the recovered refrigerant and labelled for that refrigerant (i.e. special cylinders for the recovery of refrigerant). Cylinders shall be complete with pressure-relief valve and associated shut-off valves in good working order. Empty recovery cylinders are evacuated and, if possible, cooled before recovery occurs.

The recovery equipment shall be in good working order with a set of instructions concerning the equipment that is at hand and shall be suitable for the recovery of the flammable refrigerant. If in doubt, the manufacturer should be consulted. In addition, a set of calibrated weighing scales shall be available and in good working order. Hoses shall be complete with leak-free disconnect couplings and in good condition.

The recovered refrigerant shall be processed according to local legislation in the correct recovery cylinder, and the relevant waste transfer note arranged. Do not mix refrigerants in recovery units and especially not in cylinders.

If compressors or compressor oils are to be removed, ensure that they have been evacuated to an acceptable level to make certain that flammable refrigerant does not remain within the lubricant. The compressor body shall not be heated by an open flame or other ignition sources to accelerate this process. When oil is drained from a system, it shall be carried out safely.

## 2. General

The device can return air at the bottom at the upward airflow position, return air from left to right at the horizontal position and return air at the top at the downward airflow position.

This air handler provides the flexibility to be installed in any upward, downward or horizontal airflow application. According to the airflow performance table in Section 5, adjust the fan speed through the DIP switch (located on the control panel of the air handler) to select the correct air volume. Please refer to the wiring diagram of Dip switch settings.

Please refer to section 4 for high and low voltage wiring.

To ensure proper installation, please choose a firm and flat site. Make sure enough clearance is reserved for installation and maintenance.

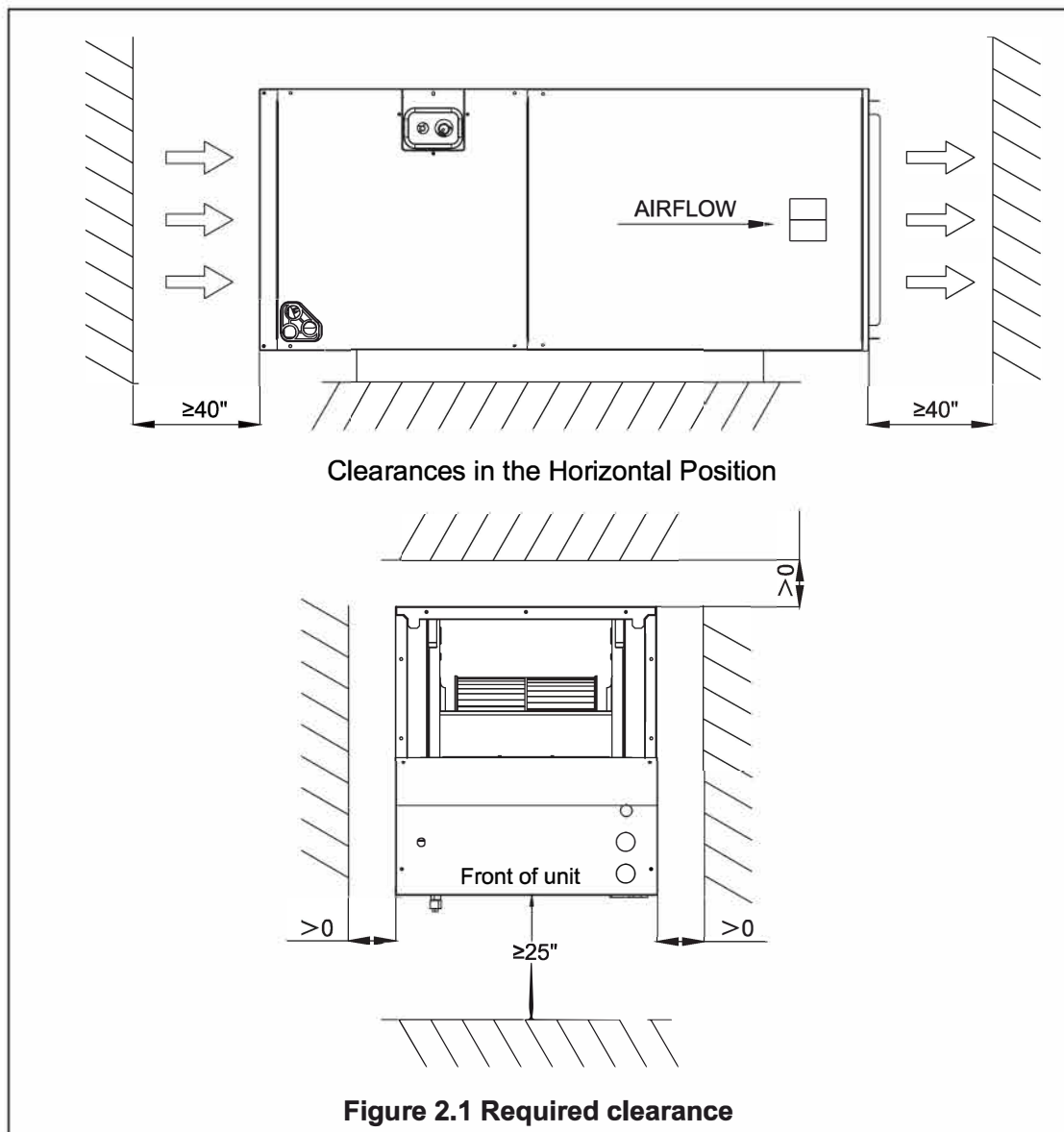



**Note:**

- As shown in Figure 2.1, the installed device must have the required clearance. Failure to follow these instructions may result in equipment damage and/or premature equipment failure.



**Warning: Fire risk**

- Keep flammable materials and vapors (such as gasoline) away from air handlers. Failure to follow these instructions may result in death, explosion or fire.

## 2.1 Installation in High Humidity Environment

When the unit is installed in a hot and humid place, if the temperature in the installation space exceeds 86 °F and the RH (relative humidity) exceeds 80%, it is recommended to insulate the outside of the cabinet. Use glass wool or polyethylene foam as insulation material; The thickness should be greater than 2 inches, and it must be suitable for the installation space opening.

Condensate may also be produced on the insulation surface. Ensure that insulation materials designed for HVAC systems are used. In the process of refrigeration, condensate may be produced on the surface. It is also recommended to use an auxiliary drain pan and fix the equipment firmly to prevent it from falling. See Figure 2.2, 2.3, 2.4 and 2.5.



For the use of auxiliary drainage tray, please refer to local regulations.

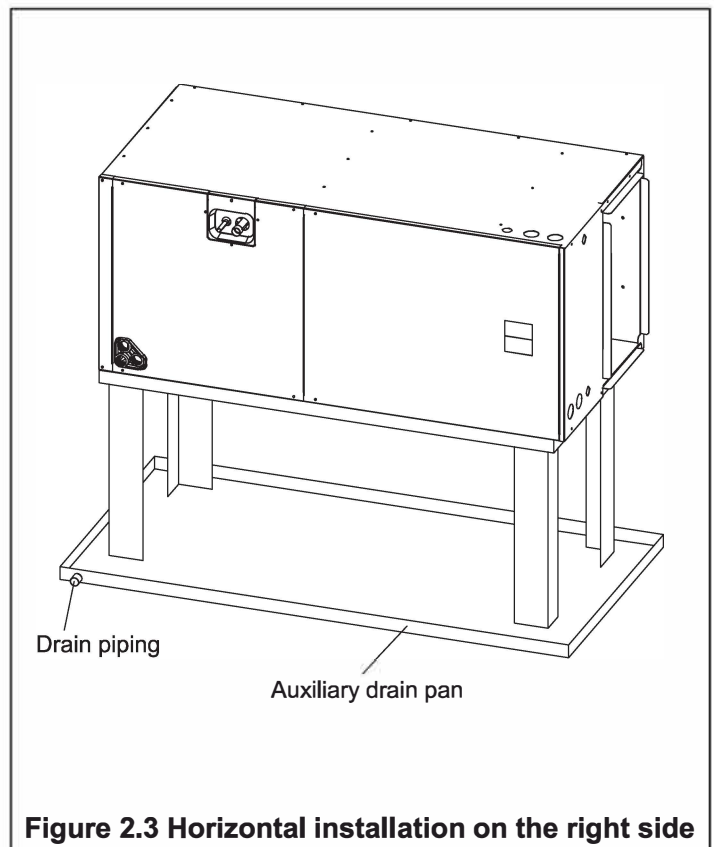
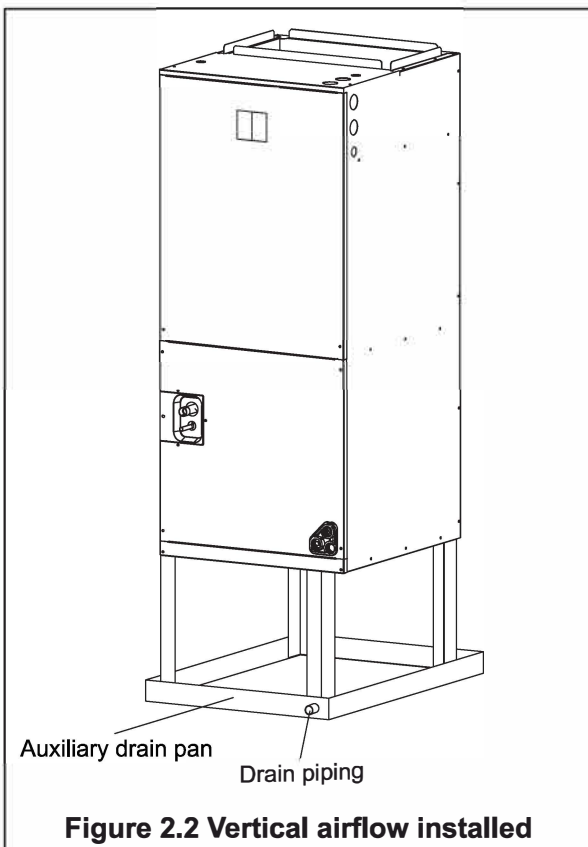

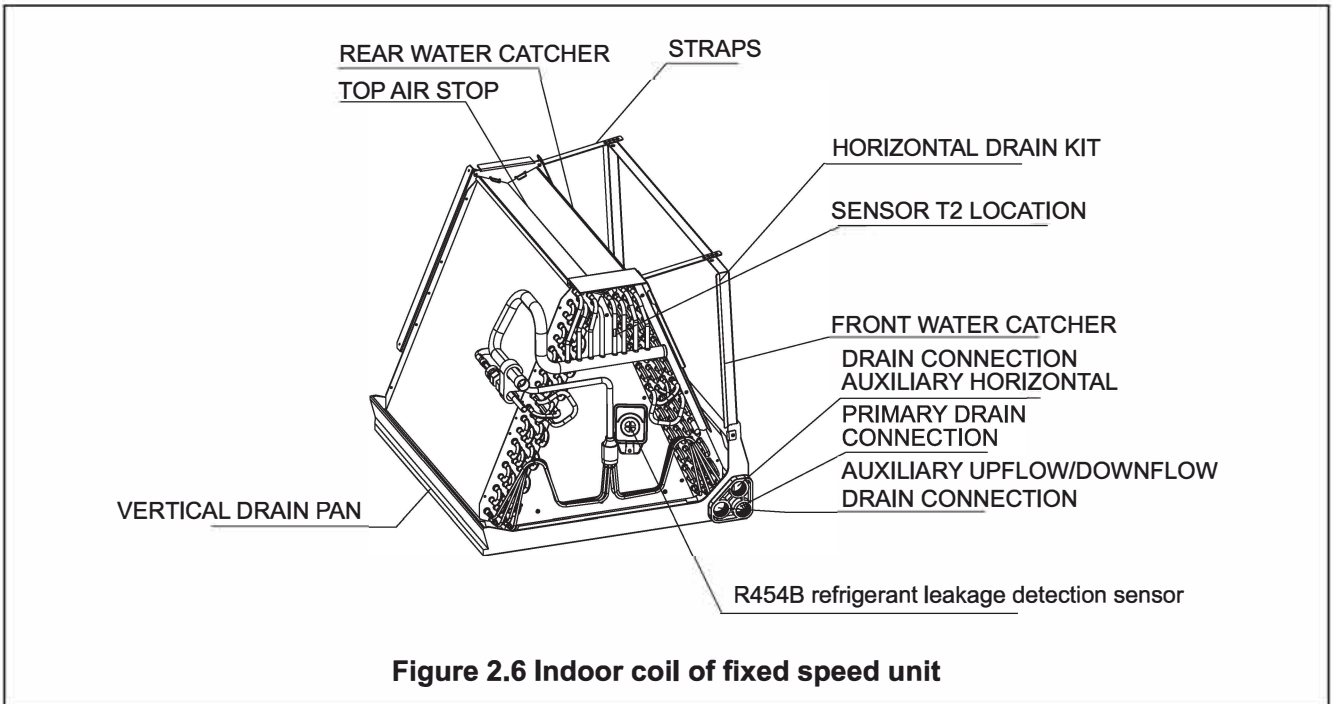
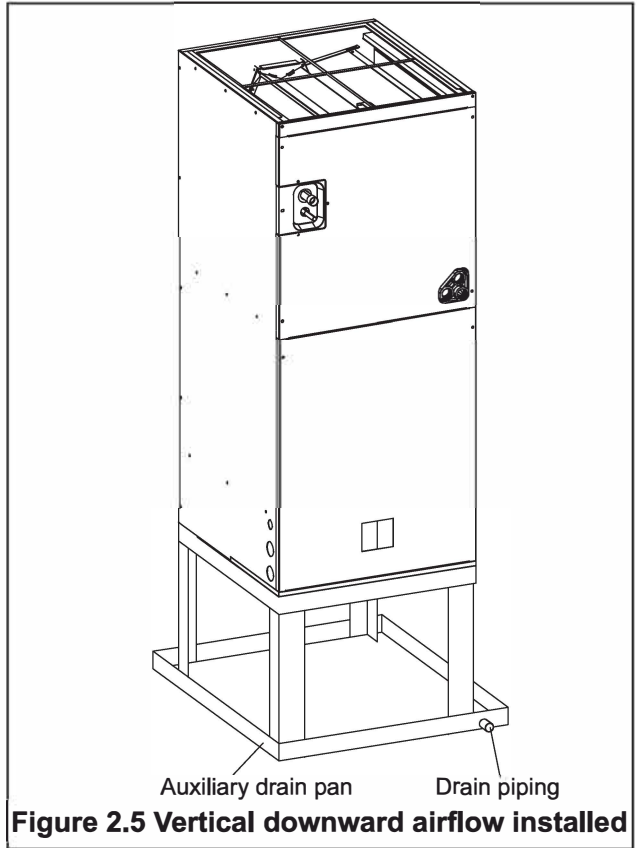
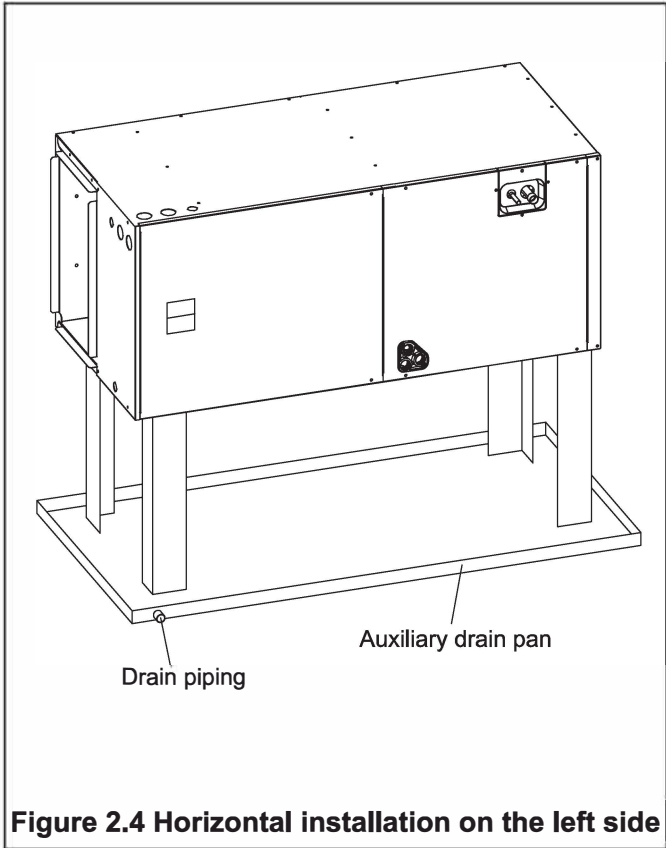

## 2.2 Unit Dimension



The front of the unit requires a clearance of 25 inches for the maintenance of filters and coils.

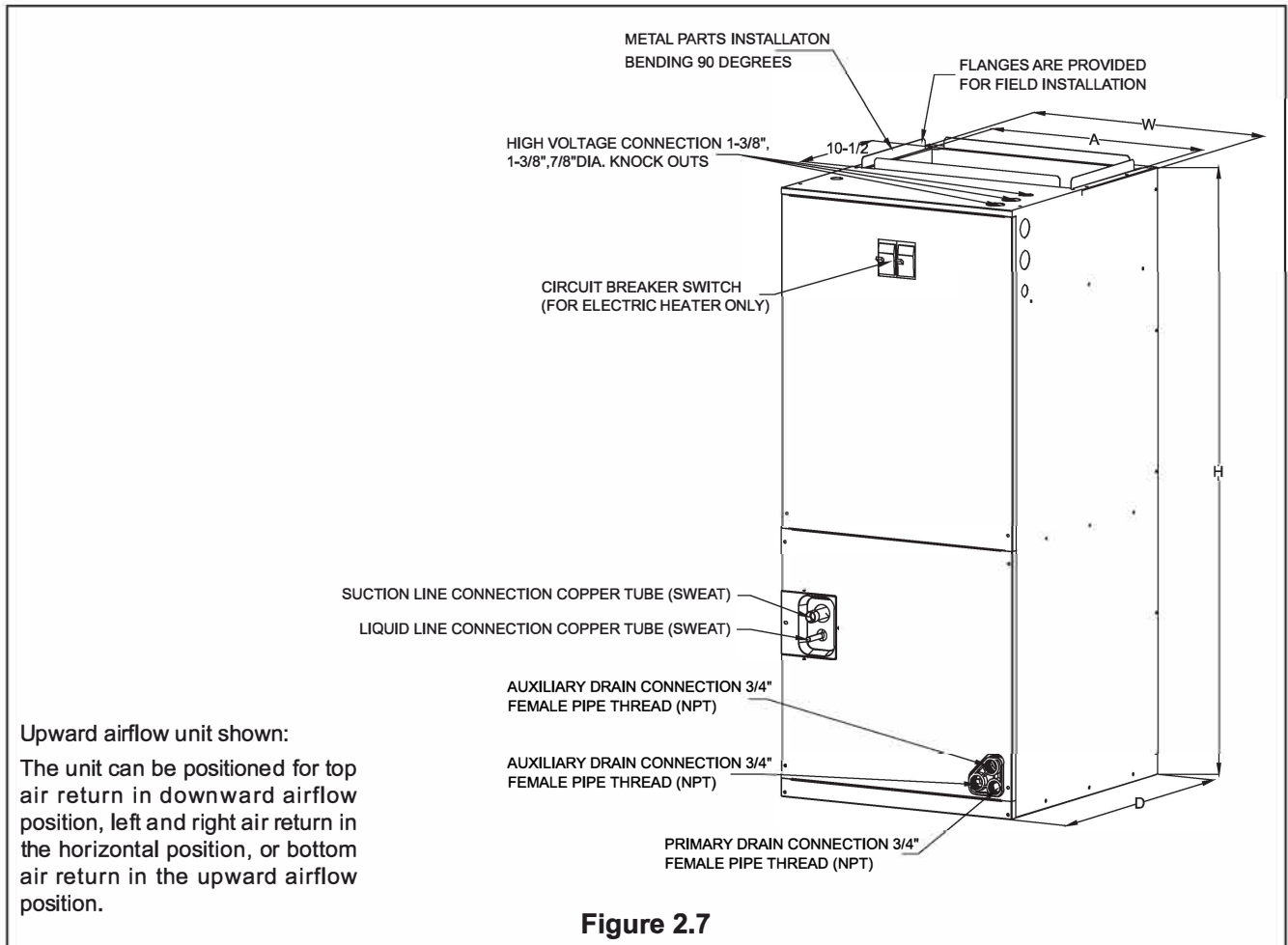

**Table 2.1 Unit Dimension**

Model	Dimension Inches [mm]				
	Height "H"	Width "W"	Dimension "D"	Air outlet "A"	Liquid Line / Vapor Line
18K	45-3/4 [1162]	19-5/8 [500]	22 [560]	17-7/8 [454]	3/8 / 3/4 [9.5]/[19]
24K	45-3/4 [1162]	19-5/8 [500]	22 [560]	17-7/8 [454]	3/8 / 3/4 [9.5]/[19]
30K	45-3/4 [1162]	19-5/8 [500]	22 [560]	17-7/8 [454]	3/8 / 3/4 [9.5]/[19]
36K	45-3/4 [1162]	19-5/8 [500]	22 [560]	17-7/8 [454]	3/8 / 3/4 [9.5]/[19]
42K	53-1/8 [1350]	22 [560]	24 -1/2[623]	19-1/2 [496]	3/8 / 7/8 [9.5]/[22]
48K	53-1/8 [1350]	22 [560]	24 -1/2[623]	19-1/2 [496]	3/8 / 7/8 [9.5]/[22]
60K	53-1/8 [1350]	22 [560]	24 -1/2[623]	19-1/2 [496]	3/8 / 7/8 [9.5]/[22]

## 3. Application

### 3.1 Vertical Upward Airflow

- The vertical upward airflow configuration is the factory default configuration of all models (see Figure 2.7).
- If the return air is to be ducted, the duct should be installed flush with the ground. Use 1/8 to 1/4 inch thick fireproof elastic gasket between ducts, unit and floor.



Torque applied to the drainage connection should not exceed 15 foot-pounds. For vertical upward air flow and horizontal right installation, dimensions of pipe and drain pipe can be found in Figure 3.1.

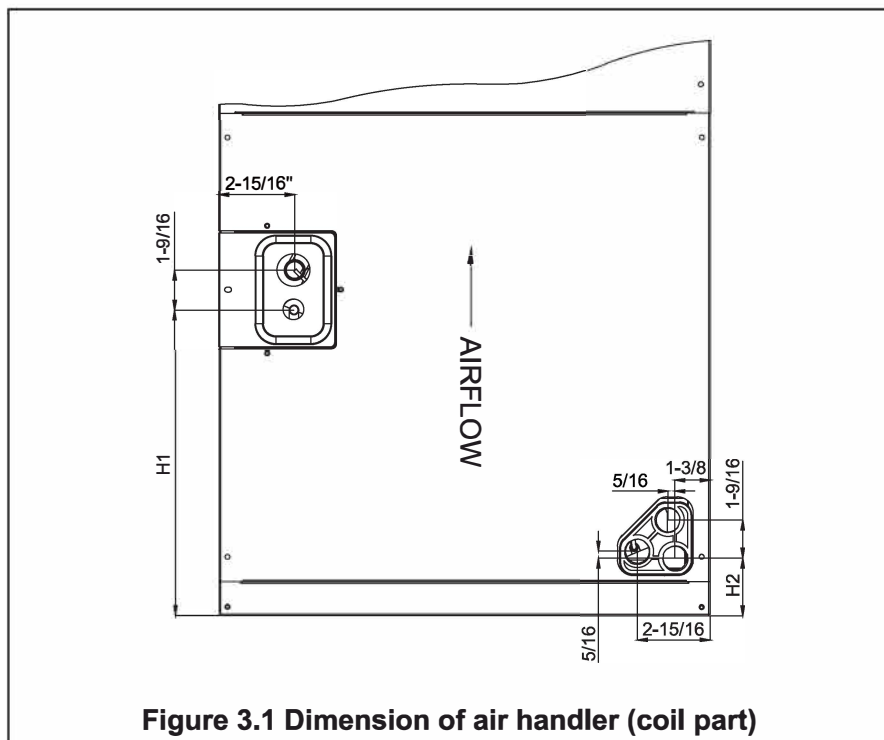

Figure 3.1 Dimension of air handler (coil part)

Table 3.1

Model	"H1" inch [mm]	"H2" inch [mm]
18K/24K/30K/36K	12-1/4 [311]	2-1/4[57]
42K/48K/60K	19[483]	1-25/32[45]

### 3.2 Vertical Downward Airflow

#### Convert to Vertical Downward airflow Position:

The vertical upward airflow position can be converted into the vertical downward airflow position. Remove the coil (evaporator) access panel and coil, and reinstall it by rotating 180° from the original position. See Figure 3.2 and 3.4.

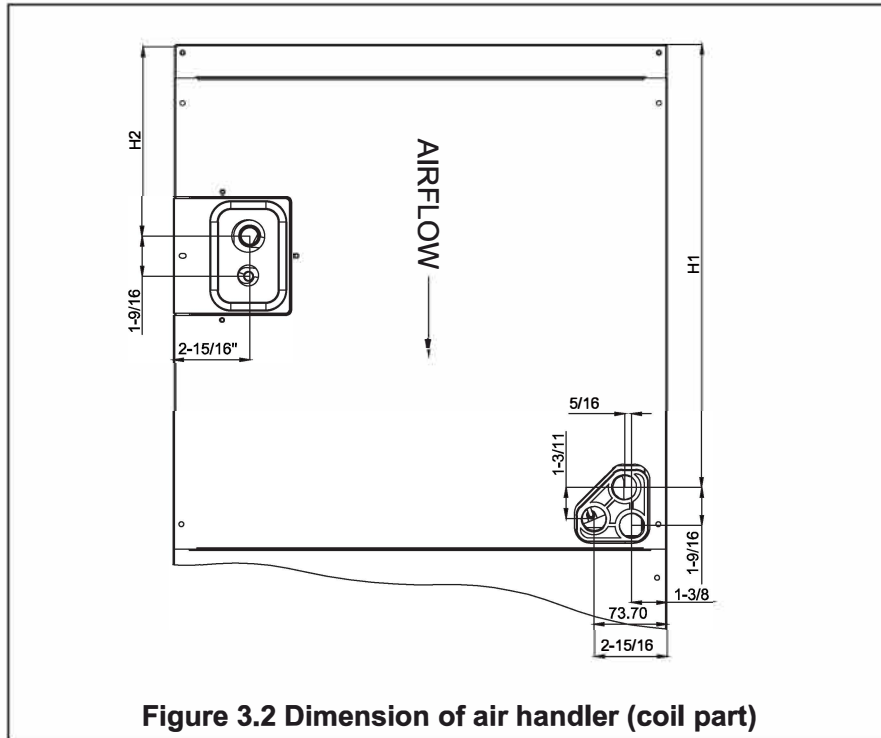

Figure 3.2 Dimension of air handler (coil part)

Table 3.2

Model	"H1" inch [mm]	"H2" inch [mm]
18K/24K/30K/36K	17-11/16 [449]	7-9/16 [192]
42K/48K/60K	21-11/16 [551]	4-13/32 [112]

### 3.3 Horizontal

Horizontal right installation is the default factory configuration for all models.

#### Switch to Horizontal Left Installation:

- By removing the indoor coil assembly and reinstalling the coil, the vertical upflow position can be converted into a horizontal left position, See Figure 3.3 and 3.4.
- Rotate the device by 90° to the horizontal left position, with the coil segment on the right and the blower segment on the left.
- Re-install the indoor coil by rotating 180° from the original position. Ensure that the fixing groove is fully engaged with the coil guide rail. See figs. 3.4.
- When configured to be placed horizontally above the ceiling and/or living space, it is recommended to use an additional field supplied drain pan.

**Steps to Change Cabinet Direction to Vertical Downward or Horizontal Left Direction**

1. Remove the screws and the front panel, and disconnect the plug of T2 sensor and R454B refrigerant leakage detection sensor wire from the circuit board (Figure 3.3, Step 1).
2. Pull out the coil with sensor wire (do not disconnect T2 sensor and R454B refrigerant leakage detection sensor from the coil). (Figure 3.3, Step 2)
3. Install the coil in the correct direction and fix it in place. Reinsert those sensor wire in PCBA through the gap on the cabinet cover (Figure 3.3, Step 3).

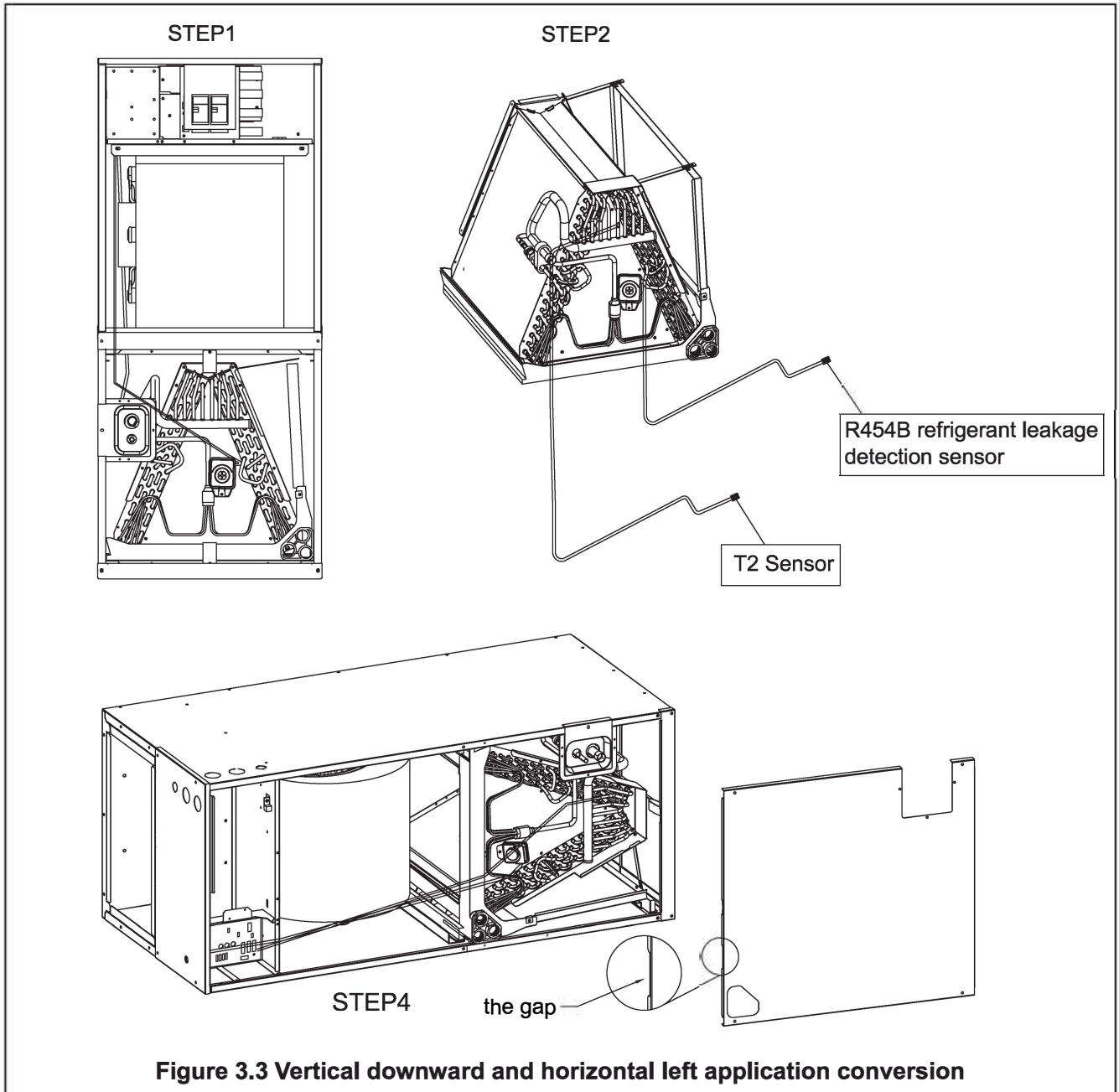

**Figure 3.3 Vertical downward and horizontal left application conversion**

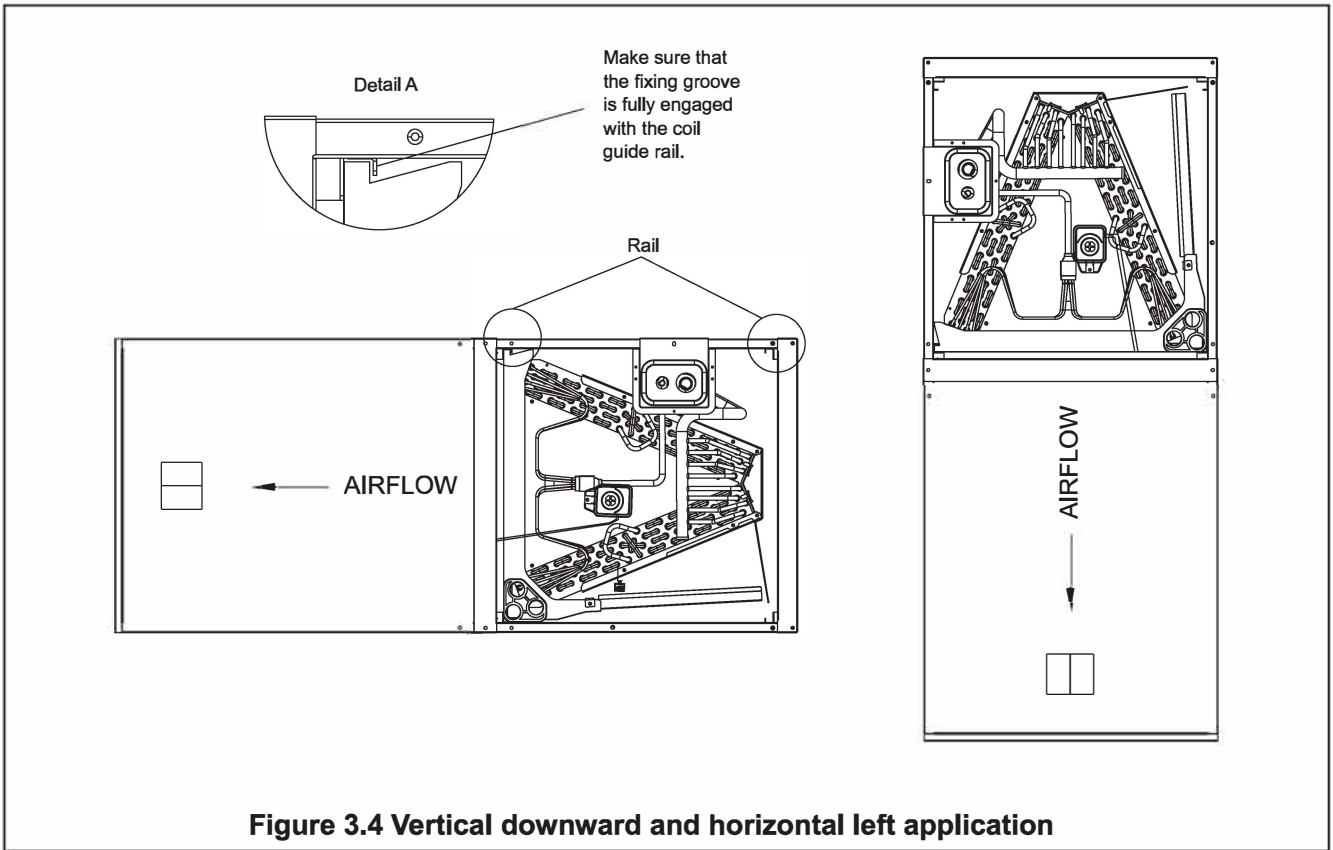

**Figure 3.4 Vertical downward and horizontal left application**

**Note:**



- Horizontal units must be configured for right hand air supply or left hand air supply. Horizontal drain pan must be located under indoor coil.
- Failure to use the drain pan will result in property damage.

**Horizontal Conversion:**

Remove the indoor coil and reinstall it by 180° from the original position. The horizontal right air outlet can be changed to the horizontal left air outlet.

**3.4 Install in Unconditioned Space**

**Note:**



- There are two pairs of coil guide rails in the air handler, which are used for upward and downward air supply applications. If the air handler is installed in an unconditioned space, two unused coil guide rails should be removed to minimize condensate on the surface of the air handler. Unscrew 6 mounting screws from both sides of the cabinet to easily remove the coil guide rail.

### 3.5 Steps to Replacing the R454B refrigerant leakage detection sensor

GENERAL SPECIFICATIONS of R454B refrigerant leakage detection sensor:

MODEL: RGD-02TL11 or AM4205H-LC-I

MINIMUM LIFETIME: 15 YEARS

It needs to be replaced with the same model. If in doubt, please consult the manufacturer for assistance.

1. Remove the screws and the front panel, and disconnect the plug of R454B refrigerant leakage detection sensor wire from the circuit board (Figure 3.5, Step 1).
2. Remove the screws and pull out the R454B refrigerant leakage detection sensor with the wire (Figure 3.5, Step 2).
3. Replace the new R454B refrigerant leakage detection sensor and screw it to the triangular plate, plug and tie the wires to the electronic control board in the same way as before. Install the access panels, make sure there is no outstanding gap to allow refrigerant escape in case of leakage.

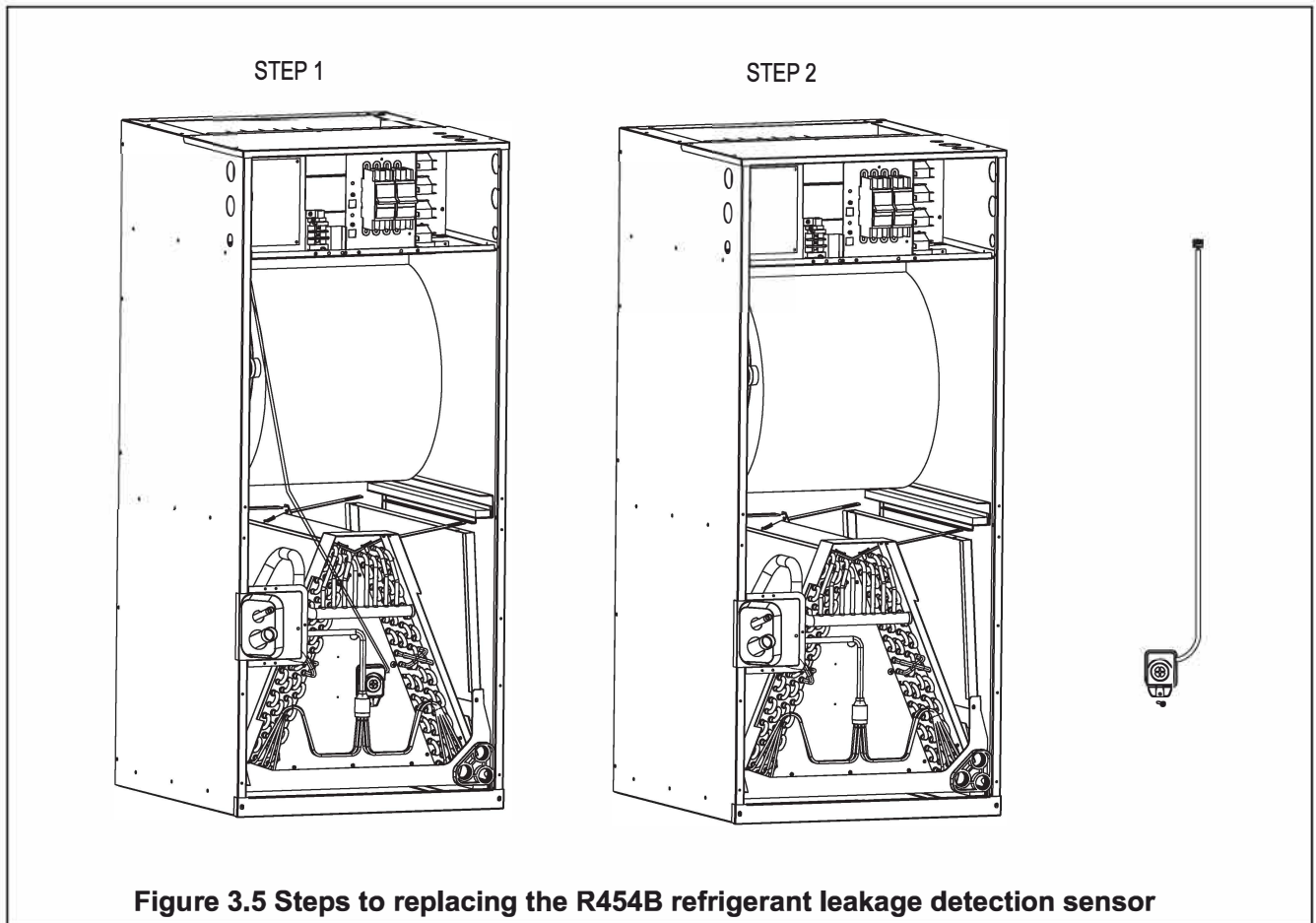

### 3.6 Precautions for Four-way Installation

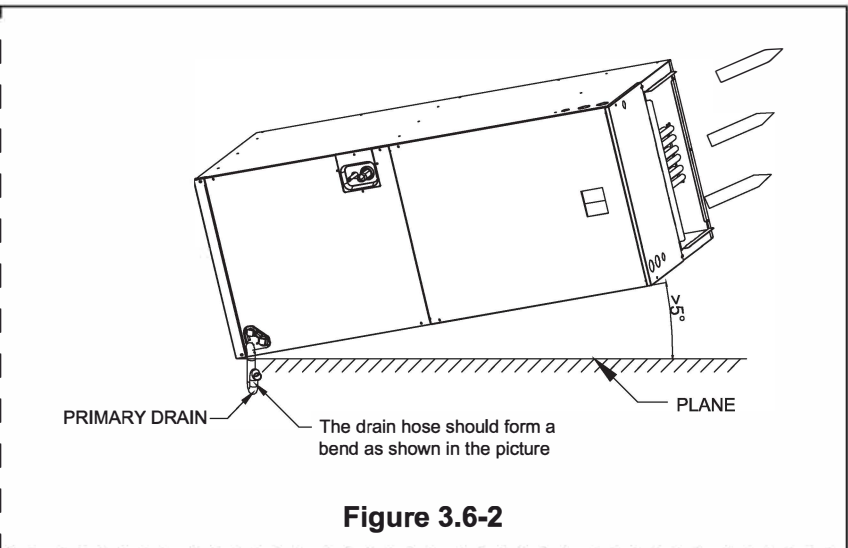
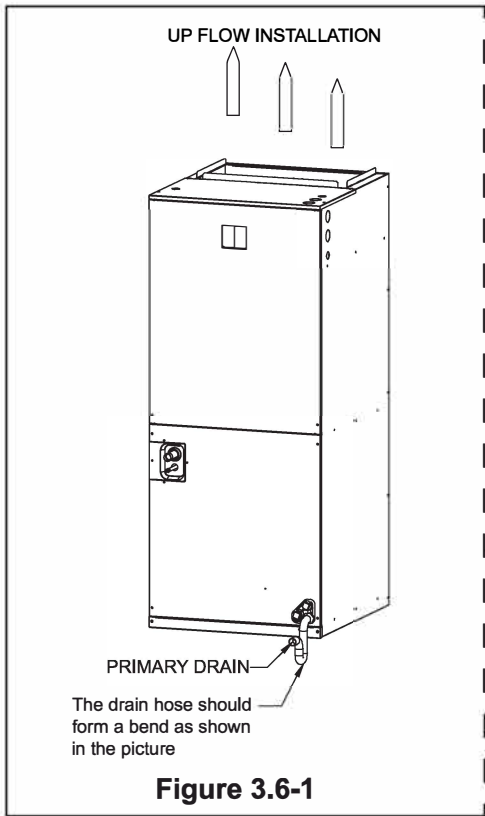

**INSTALLATION NOTES:**

1. Plug the unused drain holes with the plugs provided in the accessory bag comes with the unit.
2. The unit must be put the horizontal angel of the formation of greater than or equal to 5°.

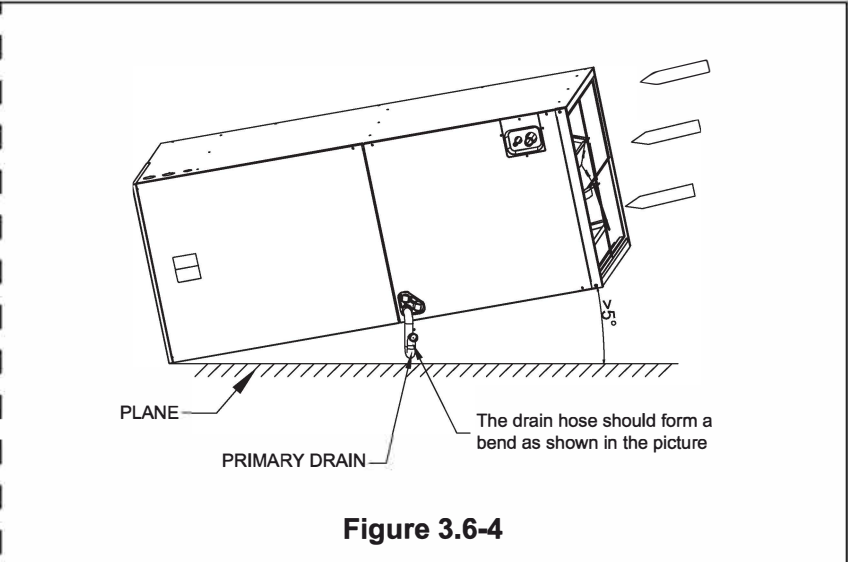
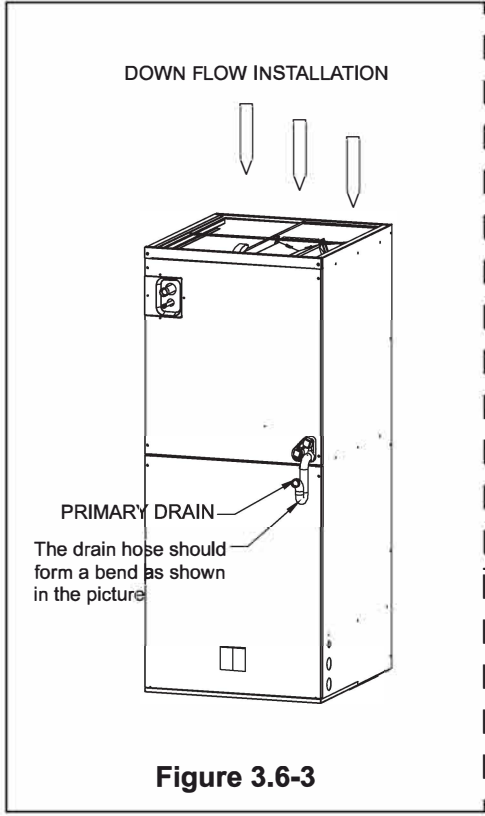

**INSTALLATION NOTES:**

1. Plug the unused drain holes with the plugs provided in the accessory bag comes with the unit.
2. The unit must be put the horizontal angel of the formation of greater than or equal to 5°.

### 3.7 Installation Room Size Rules

The installation mode needs to be performed in the following way.

Minimum room height, 2.2 m (7.22 ft) (if applicable).

Minimum room area (operating or storage), 20.76 m<sup>2</sup> (223.33 ft<sup>2</sup>).

Note: For minimum room areas at higher installation heights, see instructions (note is optional).

Installation method:

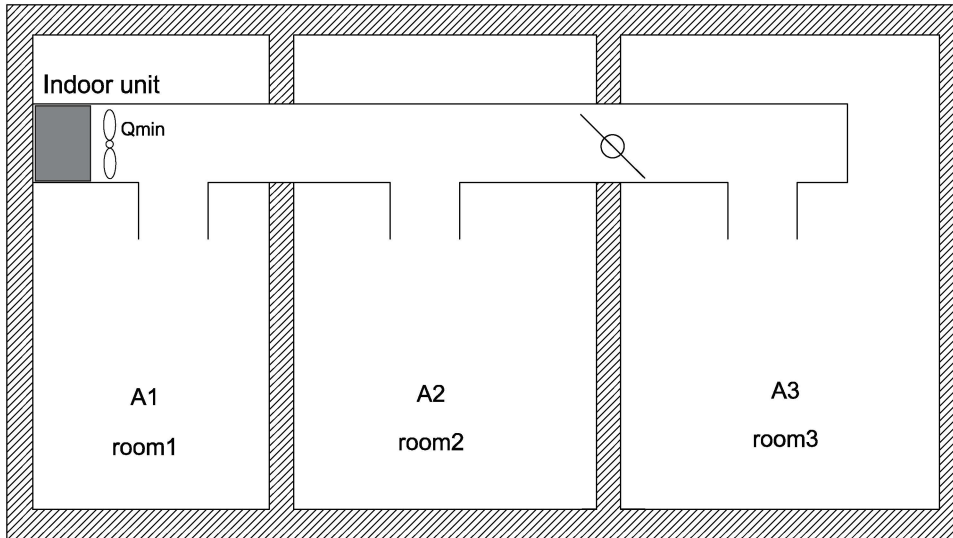

Make sure that the applied room space area TA is larger than the TA min.

**Table 3.3**

18K AC			18K HP		
Piping length (ft)/(m)	Refrigerant perfusion (oz)/(kg)	TA min (ft <sup>2</sup> )/(m <sup>2</sup> )	Piping length (ft)/(m)	Refrigerant perfusion (oz)/(kg)	TA min (ft <sup>2</sup> )/(m <sup>2</sup> )
15/(4.57)	64.55/(1.83)	60.5/(5.62)	15/(4.57)	75.13/(2.13)	70.42/(6.54)
50/(15.24)	83.37/(2.36)	78.13/(7.26)	50/(15.24)	93.95/(2.66)	88.05/(8.18)
75/(22.86)	96.81/(2.74)	90.73/(8.43)	75/(22.86)	107.39/(3.04)	100.65/(9.35)
100/(30.48)	110.25/(3.13)	103.32/(9.6)	100/(30.48)	120.83/(3.43)	113.24/(10.52)
131/(39.93)	126.92/(3.60)	118.95/(11.05)	131/(39.93)	137.5/(3.90)	128.86/(11.97)
24K AC			24K HP		
Piping length (ft)/(m)	Refrigerant perfusion (oz)/(kg)	TA min (ft <sup>2</sup> )/(m <sup>2</sup> )	Piping length (ft)/(m)	Refrigerant perfusion (oz)/(kg)	TA min (ft <sup>2</sup> )/(m <sup>2</sup> )
15/(4.57)	66.32/(1.88)	62.15/(5.77)	15/(4.57)	75.13/(2.13)	70.42/(6.54)
50/(15.24)	85.13/(2.41)	79.79/(7.41)	50/(15.24)	93.95/(2.66)	88.05/(8.18)
75/(22.86)	98.57/(2.79)	92.38/(8.58)	75/(22.86)	107.39/(3.04)	100.65/(9.35)
100/(30.48)	112.01/(3.18)	104.98/(9.75)	100/(30.48)	120.83/(3.43)	113.24/(10.52)
131/(39.93)	128.68/(3.65)	120.6/(11.2)	131/(39.93)	137.5/(3.90)	128.86/(11.97)

30K AC			30K HP		
Piping length (ft)/(m)	Refrigerant perfusion (oz)/(kg)	TA min (ft <sup>2</sup> )/(m <sup>2</sup> )	Piping length (ft)/(m)	Refrigerant perfusion (oz)/(kg)	TA min (ft <sup>2</sup> )/(m <sup>2</sup> )
15/(4.57)	75.13/(2.13)	70.42/(6.54)	15/(4.57)	99.83/(2.83)	93.56/(8.69)
50/(15.24)	93.95/(2.66)	88.05/(8.18)	50/(15.24)	118.64/(3.36)	111.19/(10.33)
75/(22.86)	107.39/(3.04)	100.65/(9.35)	75/(22.86)	132.08/(3.74)	123.79/(11.5)
100/(30.48)	120.83/(3.43)	113.24/(10.52)	100/(30.48)	145.52/(4.13)	136.38/(12.67)
131/(39.93)	137.5/(3.90)	128.86/(11.97)	131/(39.93)	162.19/(4.60)	152/(14.12)
36K AC			36K HP		
Piping length (ft)/(m)	Refrigerant perfusion (oz)/(kg)	TA min (ft <sup>2</sup> )/(m <sup>2</sup> )	Piping length (ft)/(m)	Refrigerant perfusion (oz)/(kg)	TA min (ft <sup>2</sup> )/(m <sup>2</sup> )
15/(4.57)	91.01/(2.58)	85.29/(7.92)	15/(4.57)	110.41/(3.13)	103.47/(9.61)
50/(15.24)	109.83/(3.11)	102.93/(9.56)	50/(15.24)	129.23/(3.66)	121.11/(11.25)
75/(22.86)	123.26/(3.49)	115.52/(10.73)	75/(22.86)	142.67/(4.04)	133.71/(12.42)
100/(30.48)	136.7/(3.88)	128.12/(11.9)	100/(30.48)	156.1/(4.43)	146.3/(13.59)
131/(39.93)	153.37/(4.35)	143.74/(13.35)	131/(39.93)	172.77/(4.90)	161.92/(15.04)
42K AC			42K HP		
Piping length (ft)/(m)	Refrigerant perfusion (oz)/(kg)	TA min (ft <sup>2</sup> )/(m <sup>2</sup> )	Piping length (ft)/(m)	Refrigerant perfusion (oz)/(kg)	TA min (ft <sup>2</sup> )/(m <sup>2</sup> )
25/(7.62)	126.98/(3.60)	118.95/11.06	25/(7.62)	141.09/(4.00)	132.17/12.29
50/(15.24)	140.48/(3.98)	131.54/12.23	50/(15.24)	154.59/(4.38)	144.76/13.46
75/(22.86)	153.98/(4.36)	144.13/13.40	75/(22.86)	168.09/(4.76)	157.34/14.63
100/(30.48)	167.48/(4.74)	156.72/14.57	100/(30.48)	181.59/(5.14)	169.93/15.80
131/(39.93)	184.22/(5.22)	172.33/16.02	131/(39.93)	198.33/(5.62)	185.55/17.25
48K AC			48K HP		
Piping length (ft)/(m)	Refrigerant perfusion (oz)/(kg)	TA min (ft <sup>2</sup> )/(m <sup>2</sup> )	Piping length (ft)/(m)	Refrigerant perfusion (oz)/(kg)	TA min (ft <sup>2</sup> )/(m <sup>2</sup> )
25/(7.62)	134.04/(3.80)	125.56/11.67	25/(7.62)	137.57/(3.90)	128.86/11.98
50/(15.24)	147.54/(4.18)	138.15/12.84	50/(15.24)	151.07/(4.28)	141.45/13.15
75/(22.86)	161.04/(4.56)	150.74/14.01	75/(22.86)	164.57/(4.66)	154.04/14.32
100/(30.48)	174.54/(4.94)	163.33/15.18	100/(30.48)	178.07/(5.04)	166.63/15.49
131/(39.93)	191.28/(5.42)	178.94/16.63	131/(39.93)	194.81/(5.52)	182.24/16.94
147/(44.80)	199.92/(5.66)	186.98/17.38	147/(44.80)	203.45/(5.76)	190.29/17.69

60K AC			60K HP		
Piping length (ft)/(m)	Refrigerant perfusion (oz)/(kg)	TA min (ft <sup>2</sup> )/(m <sup>2</sup> )	Piping length (ft)/(m)	Refrigerant perfusion (oz)/(kg)	TA min (ft <sup>2</sup> )/(m <sup>2</sup> )
25/(7.62)	165.78/(4.70)	155.30/14.43	25/(7.62)	165.78/(4.70)	161.90/15.05
50/(15.24)	179.28/(5.08)	167.89/15.61	50/(15.24)	179.28/(5.08)	174.49/16.22
75/(22.86)	192.78/(5.46)	180.47/16.78	75/(22.86)	192.78/(5.46)	187.08/17.39
100/(30.48)	206.28/(5.84)	193.06/17.95	100/(30.48)	206.28/(5.84)	199.67/18.56
131/(39.93)	223.02/(6.32)	208.68/19.40	131/(39.93)	230.08/(6.52)	215.28/20.01
147/(44.80)	231.66/(6.56)	216.72/20.14	147/(44.80)	231.66/(6.56)	223.33/20.76

Note: TA=A1+A2+A3+...+An (If there is a damper in the duct. When damper is open, the room area TA is the sum of all room area connected by ductwork. If it is closed, TA is the sum of the room areas before the damper.)

Table: Minimum room area/zone de chambre minimale (e.g.: 36K AC Installation connection piping length of 15 feet and refrigerant charge of 91.01oz results in an installation room area of not less than 83.32 sq. ft.)

**Table 3.4**

Model	Qmin [m <sup>3</sup> /h(SCFM)]	Qmin <sub>A</sub> [m <sup>3</sup> /h(SCFM)]
18K AC	451/(265)	315/(185)
18K HP	451/(265)	367/(216)
24K AC	451/(265)	324/(191)
24K HP	451/(265)	367/(216)
30K AC	667/(392)	367/(216)
30K HP	667/(392)	488/(287)
36K AC	667/(392)	445/(261)
36K HP	667/(392)	539/(317)
42K AC	1322 (778)	517 (304)
42K HP	1322 (778)	556 (327)
48K AC	1322 (778)	560 (330)
48K HP	1322 (778)	570 (335)
60K AC	1361 (801)	650 (382)
60K HP	1361 (801)	669 (394)

Note: Qmin refers to the Minimum airflow of the indoor unit (see Table 5.1 for details), which is not less than Qmin<sub>A</sub>.

## 4. Electrical Wiring

The wiring on site must comply with the National Electric Code (C.E.C. in Canada) and any applicable local regulations.



### Warning: Electric shock

- Before installation or maintenance, please disconnect all power supply of the device. More than one disconnect switch may be required to cut off the power of the equipment. Dangerous voltage can cause serious personal injury or death.

### 4.1 Power Supply Wiring

It is important to have a suitable power supply connected to the device being installed. For more detailed requirements, please refer to the device rating label, wiring diagram and electrical data in the installation instructions.

- If necessary, install a branch circuit breaker of sufficient size, which is located within sight and easy to install.



When installing an electric heater, the device may be equipped with one or two 30-60 amp circuit breakers. These circuit breakers protect internal lines and act as disconnecting devices when short circuit occurs. The circuit breaker installed in the device does not provide overcurrent protection for the power connection, so its size may be larger than that of the branch circuit protection.

- The power supply line of the circuit must be a minimum 221°F copper conductor. For current carrying capacity, wire size and circuit protector requirements, please refer to electrical data in this section. The power supply protection device can be a fuse or a "HACR" type circuit breaker.
- High-voltage wires can pass through the tapping holes on the right, left or top of the device.
- 7/8", 1-3/8" diameter tapped holes can be used to connect high-voltage wires to the device.
- The high-voltage wires must be connected to the red and black wires in the control part of the air handler.

### 4.2 Control Wiring



The low-voltage control line should not run in the conduit together with the high-voltage line. Keep the distance between the two catheters according to local codes.

- Scenes less than 100 feet in length should use 18 AWG colored low-voltage wires. 16 AWG wire should be used for scenes with a length of more than 100 feet.
- See Figure 2.7 for the connection position of low-voltage wires.
- For the correct wiring instructions, please refer to the wiring diagram located back side of the air handler blower access panel.
- After installation, make sure that the low-voltage and high-voltage wiring are kept separate.

### 4.3 Grounding



### Danger: Electric shock

- The device must be permanently grounded. Otherwise, it will cause electric shock, personal injury or death.

- When installed according to existing electrical codes, grounding can be through wires or metal conductors.
- Grounding can also be achieved by connecting the grounding wire to the ground lug (ground lug) on the machine.
- When multiple power supply circuits are used, each circuit needs to be grounded plate separately.
- The grounding plate is located at the upper right of the cabinet.

## 4.4 Electrical Data

**Table 4.1 Electrical Data**

Model	Voltage	Hertz	HP	Fan speed	Circuit AMPS	MCA(A)	MOP(A)
18K	208/230	60	1/3	5	1.1	4	6
24K	208/230	60	1/3	5	1.1	4	6
30K	208/230	60	1/2	5	2.0	5	6
36K	208/230	60	1/2	5	2.0	5	6
42K	208/230	60	3/4	5	3.5	7	10
48K	208/230	60	3/4	5	3.5	7	10
60K	208/230	60	3/4	5	4.3	7	10

## 4.5 MCA/MOP Data of Electric Heat Kit

**Table 4.2 Applicable Heat Kits for AHU Multi Position Installation**

Heat kit model	AHU model	electric heat(kW) 208/230VAC	Current (A) 208/230VAC	MCA (A) 208/230VAC	MAX.Fuse or Breaker (HACR) Ampacity		Fan speed				
					208 VAC	230 VAC	1	2	3	4	5
CHE6-05B	18K	3.8/5	19.66/21.74	25/29	30	35	●	●	●	●	●
CHE6-08B		5.6/7.5	29.50/32.61	37/43	40	45	x	x	●	●	●
CHE6-05B	24K	3.8/5	19.66/21.74	25/29	30	35	●	●	●	●	●
CHE6-08B		5.6/7.5	29.50/32.61	37/43	40	45	x	x	●	●	●
CHE6-10B		7.5/10	39.32/43.48	50/57	55	60	x	x	x	●	●
CHE6-05B	30K	3.8/5	19.66/21.74	25/29	30	35	●	●	●	●	●
CHE6-08B		5.6/7.5	29.50/32.61	37/43	40	45	x	●	●	●	●
CHE6-10B		7.5/10	39.32/43.48	50/57	55	60	x	x	●	●	●
CHE6-05B	36K	3.8/5	19.66/21.74	25/29	30	35	●	●	●	●	●
CHE6-08B		5.6/7.5	29.50/32.61	37/43	40	45	x	●	●	●	●
CHE6-10B		7.5/10	39.32/43.48	50/57	55	60	x	x	●	●	●
CHE6-15B		(5.6+5.6) /(7.5+7.5)	29.50+29.50/32.61+32.61	37+37/43+43	40/40	45/45	x	x	x	●	●

CHE6-05B	42K	3.8/5	19.66/21.74	25/29	30	35	●	●	●	●	●
CHE6-08B		5.6/7.5	29.50/32.61	37/43	40	45	●	●	●	●	●
CHE6-10B		7.5/10	39.32/43.48	50/57	55	60	×	●	●	●	●
CHE6-15B		(5.6+5.6) /(7.5+7.5)	29.50+29.50/32.61+32.61	37+37/43+43	40/40	45/45	×	×	●	●	●
CHE6-05B	48K	3.8/5	19.66/21.74	25/29	30	35	●	●	●	●	●
CHE6-08B		5.6/7.5	29.50/32.61	37/43	40	45	●	●	●	●	●
CHE6-10B		7.5/10	39.32/43.48	50/57	55	60	×	●	●	●	●
CHE6-15B		(5.6+5.6) /(7.5+7.5)	29.50+29.50/32.61+32.61	37+37/43+43	40/40	45/45	×	×	●	●	●
CHE6-20B		(7.5+7.5) /(10+10)	39.32+39.32/43.48+43.48	50+50/57+57	55/55	60/60	×	×	×	●	●
CHE6-05B	60K	3.8/5	19.66/21.74	25/29	30	35	●	●	●	●	●
CHE6-08B		5.6/7.5	29.50/32.61	37/43	40	45	●	●	●	●	●
CHE6-10B		7.5/10	39.32/43.48	50/57	55	60	×	●	●	●	●
CHE6-15B		(5.6+5.6) /(7.5+7.5)	29.50+29.50/32.61+32.61	37+37/43+43	40/40	45/45	×	×	●	●	●
CHE6-20B		(7.5+7.5) /(10+10)	39.32+39.32/43.48+43.48	50+50/57+57	55/55	60/60	×	×	×	●	●

- Heat kit applicable for AHU 4-way position installation.
- Ampacities for MCA and Fuse/breaker including the blower motor.
- The heat pump system needs specific airflow. Each ton of cooling requires 350 to 450 cubic feet of air per minute (CFM) , or nominally 400 CFM.

**Table 4.3 Heater Kit Accessories**

Heat kit model Market Model/ Factory Model	Description	18	24	30	36	42	48	60
CHE6-05B	5 kW heating kit, single-pole circuit breaker	●	●	●	●	●	●	●
CHE6-08B	7.5 kW heating kit, single-pole circuit breaker	●	●	●	●	●	●	●
CHE6-10B	10 kW heating kit, single/double pole circuit breaker	×	●	●	●	●	●	●
CHE6-15B	15 kW heating kit, double pole circuit breaker	×	×	×	●	●	●	●
CHE6-20B	20 kW heating kit, double pole circuit breaker	×	×	×	×	×	●	●

- indicates availability, and × indicates unavailability

**Warning:**



- This product is used with A2L type refrigerant, the electric heater must meet the requirements of the UL 60335-2-40 standard for A2L type refrigerant.
- The electric heating must be installed by qualified personnel. Refer to current regulations and laws for installation location.
- This appliance is not intended for use by persons (including children) with reduced physical, sensory or mental capabilities, or lack of experience and knowledge, unless they have been given supervision or instruction concerning use of the appliance by a person responsible for their safety. Children should be supervised to ensure that they do not play with the appliance.
- The appliance shall be installed in accordance with national wiring regulations.

## 5. Airflow Performance

The air flow data is based on the cooling performance of coil and without filter.

External static pressure ESP should be kept within the minimum and maximum limits shown in the following table to ensure the normal operation of cooling, heating and electric heating.

**Table 5.1 Air Flow Performance**

Model size of air processor	Motor speed		SCFM								
			External Static Pressure-Inch Water Column [kPa]								
			0[0]	0.1[.025]	0.2[.050]	0.3[.075]	0.4[.100]	0.5[.125]	0.6[.150]	0.7[.175]	0.8[.200]
18K	Tap (1)	SCFM	669.9	571.8	490.9	394.3	269.5	-	-	-	-
		Watts	41	47	52	57	61	-	-	-	-
	Tap (2)	SCFM	792.2	708.6	615.9	548.5	474.2	371.5	265.1	-	-
		Watts	59	67	73	77	83	88	93	-	-
	Tap (3)	SCFM	948.8	887.5	809.6	723.6	671.6	597.0	504.2	410.2	-
		Watts	96	102	109	115	129	126	132	141	-
	Tap (4)	SCFM	1020.9	966.5	887.1	798.4	738.8	697.9	672.3	572.8	490.1
		Watts	118	127	136	144	150	156	160	167	177
	Tap (5)	SCFM	1115.2	1059.2	995.0	906.5	842.5	791.4	727.2	707.0	652.5
		Watts	148	157	167	178	186	191	198	205	211
24K	Tap (1)	SCFM	669.9	571.8	490.9	394.3	269.5	-	-	-	-
		Watts	41	47	52	57	61	-	-	-	-
	Tap (2)	SCFM	792.2	708.6	615.9	548.5	474.2	371.5	265.1	-	-
		Watts	59	67	73	77	83	88	93	-	-
	Tap (3)	SCFM	948.8	887.5	809.6	723.6	671.6	597.0	504.2	410.2	-
		Watts	96	102	109	115	129	126	132	141	-
	Tap (4)	SCFM	1020.9	966.5	887.1	798.4	738.8	697.9	672.3	572.8	490.1
		Watts	118	127	136	144	150	156	160	167	177
	Tap (5)	SCFM	1115.2	1059.2	995.0	906.5	842.5	791.4	727.2	707.0	652.5
		Watts	148	157	167	178	186	191	198	205	211

30K	Tap (1)	SCFM	955.3	897.8	839.5	739.4	655.3	575.9	511.5	432.4	392.2
		Watts	91	96	102	110	115	121	127	138	140
	Tap (2)	SCFM	1080.7	1031.5	977.4	925.6	819.4	743.8	675.5	608.7	547.1
		Watts	125	131	137	143	153	160	166	173	179
	Tap (3)	SCFM	1182.2	1138.1	1089.0	1042.9	986.9	879.5	811.4	749.5	689.2
		Watts	158	165	172	177	185	197	203	212	221
	Tap (4)	SCFM	1305.6	1261.8	1220.9	1179.5	1132.2	1086.1	984.1	914.5	856.6
		Watts	207	214	221	228	236	244	257	266	273
	Tap (5)	SCFM	1386.7	1350.0	1309.4	1274.6	1233.1	1186.6	1137.8	1031.5	970.0
		Watts	245	253	262	270	277	285	295	309	318
36K	Tap (1)	SCFM	955.3	897.8	839.5	739.4	65.5	575.9	511.5	432.4	392.2
		Watts	91	96	102	110	115	121	127	138	140
	Tap (2)	SCFM	1080.7	1031.5	977.4	925.6	819.4	743.8	675.5	608.7	547.1
		Watts	125	131	137	143	153	160	166	173	179
	Tap (3)	SCFM	1182.2	1138.1	1089.0	1042.9	986.9	879.5	811.4	749.5	689.2
		Watts	158	165	172	177	185	197	203	212	221
	Tap (4)	SCFM	1305.6	1261.8	1220.9	1179.5	1132.2	1086.1	984.1	914.5	856.6
		Watts	207	214	221	228	236	244	257	266	273
	Tap (5)	SCFM	1386.7	1350.0	1309.4	1274.6	1233.1	1186.6	1137.8	1031.5	970.0
		Watts	245	253	262	270	277	285	295	309	318
42K	Tap (1)	SCFM	1343.9	1271.9	1208.5	1150.9	1085.5	1042.0	899.4	839.6	777.6
		Watts	141.9	150.5	159.2	168	175	185	196	202	210
	Tap (2)	SCFM	1513.9	1451.5	1392.2	1320.2	1266.8	1211.4	1148.5	1036.2	975.4
		Watts	194.2	203.9	214	220.2	228.8	238.7	247.9	264.2	271.9
	Tap (3)	SCFM	1672.5	1620.5	1562.0	1522.0	1470.6	1422.7	1371.1	1309.8	1204.8
		Watts	259	271	282	293	303	312	323	333	353
	Tap (4)	SCFM	1807.3	1781.4	1731.6	1686.0	1640.4	1595.5	1547.1	1509.5	1460.8
		Watts	328.4	343.6	357.5	370.6	385.6	395.2	407	418	430
	Tap (5)	SCFM	2048.0	2000.5	1950.9	1905.3	1861.4	1819.2	1776.4	1729.9	1684.1
		Watts	447	462	476	491	507	520	525.6	538	550
48K	Tap (1)	SCFM	1343.9	1271.9	1208.5	1150.9	1085.5	1042.0	899.4	839.6	777.6
		Watts	141.9	150.5	159.2	168	175	185	196	202	210
	Tap (2)	SCFM	1513.9	1451.5	1392.2	1320.2	1266.8	1211.4	1148.5	1036.2	975.4
		Watts	194.2	203.9	214	220.2	228.8	238.7	247.9	264.2	271.9
	Tap (3)	SCFM	1672.5	1620.5	1562.0	1522.0	1470.6	1422.7	1371.1	1309.8	1204.8
		Watts	259	271	282	293	303	312	323	333	353
	Tap (4)	SCFM	1807.3	1781.4	1731.6	1686.0	1640.4	1595.5	1547.1	1509.5	1460.8
		Watts	328.4	343.6	357.5	370.6	385.6	395.2	407	418	430
	Tap (5)	SCFM	2048.0	2000.5	1950.9	1905.3	1861.4	1819.2	1776.4	1729.9	1684.1
		Watts	447	462	476	491	507	520	525.6	538	550
60K	Tap (1)	SCFM	1275.4	1220.3	1165.5	1115.8	1051.6	974.7	913.6	859.1	800.6
		Watts	153	163	173	183	194	203	212	220	231
	Tap (2)	SCFM	1435.1	1381.7	1335.1	1289.5	1243.6	1186.2	1113.6	1075.9	1016.2
		Watts	210	220	232	243	254	266	276	287	297
	Tap (3)	SCFM	1610.6	1567.1	1528.1	1482.2	1440.8	1396.1	1350.6	1261.8	1219.6
		Watts	287	301	313	325	336	355	361	381	391
	Tap (4)	SCFM	1756.8	1718.5	1674.5	1633.8	1601.1	1557.2	1519.5	1475.1	1426.2
		Watts	366	376	392	405	415	431	444	459	472
	Tap (5)	SCFM	1917.1	1882.9	1842.6	1798.9	1772.9	1734.2	1700.6	1662.9	1622.4
		Watts	467	482	496	512	525	542	553	569	584

 The highlighted area indicates the airflow within the required range of 300-450cfm/ton.

Note:

1. The advanced airflow must be used as the rated airflow for the operation of the machine.
2. The rated airflow of a system without an electric heater kit requires 300 to 450 cubic feet of air per minute (CFM).
3. The rated airflow of a system with an electric heater kit requires 350 to 450 cubic feet of air per minute (CFM).
4. The air distribution system has the greatest influence on air flow. Therefore, the contractor should only use the procedures recognized by the industry.
5. The design and construction of air duct should be done carefully. Poor design or process will lead to a significant decline in system performance.
6. The air supply duct should be set along the periphery of the air-conditioned space with appropriate size. Improper location or insufficient airflow may lead to insufficient ventilation or noise in the ductwork.
7. The installer should balance the air distribution system to ensure that all rooms in the room have proper quiet airflow. The speedometer or airflow hood can be used to balance and verify the branch duct and system airflow (CFM).

## **5.1 Indoor Fan Function**

### **5.1.1. Indoor Coil Anti-Freezing Function**

The function utilizes the indoor coil sensor(T2) to determine whether the indoor coil is freezing or not. The feature prevents the unit running at low evaporating temperature as well as low suction superheat.

When all the following conditions are met, the Anti-Freezing Function will activate:

- A.  $T2 < 32^{\circ}\text{F}$
- B.  $32 - T2 \geq 5.4$

When the following conditions are met, the Anti-Freezing Function will deactivate:

- A.  $T2 \geq 42.8^{\circ}\text{F}$

When the feature is activated, the compressor will be turned off.

### **5.1.2. R454B Leakage Detection Function**

The function utilizes a R454B refrigerant sensor to detect the R454B concentration. Terminal F is reserved for connecting buzzer if needed.

When R454B leakage occur in the indoor coil and the concentration is above 10%, the unit will perform as the following:

- A. Cut off power to thermostat to stop compressor from continuing operation.
- B. Electric Heat kit will be turned off.
- C. High voltage will be output between terminal F and terminal L2 and the buzzer will be turned on.

## 6. Ductwork

On-site ductwork must comply with National Fire Protection Association NFPA 90A, NFPA 90B and any applicable local ordinance(s).



### Warning: Fire and carbon monoxide

- Under no circumstances should the return ductwork be connected to any other heat-producing equipment, such as mantelpiece, stove, etc. Unauthorized use of such equipment may cause fire, carbon monoxide poisoning, explosion, personal injury or property damage.

The metal ductwork operating in the air-conditioned space must be insulated and covered with a moisture-proof layer. If the construction and installation are carried out according to SMACNA glass fiber duct construction standard, the fiber duct system can be used. The ductwork must meet the U/L standard 181 test of Class I air duct by National Fire Protection Association of America. Check the local regulations of ductwork and insulation requirements.

- The duct system must be designed within the external static pressure range of the designed operation of the device. Adequate airflow in the system is very important. Ensure that the supply and return ductwork, grid, special filter screen, accessories, etc. are included in the total resistance. Please refer to the airflow performance table in Section 5 of this manual.
- Design the ductwork according to "ACCA" manual "D" residential air conditioning design and equipment selection in winter and summer. The latest version can be obtained from "ACCA" American Air Conditioning Contractors Association, 1513 16th Street NW, Washington, DC, 20036. If the ductwork contains flexible air pipes, make sure that the system takes into account the pressure drop information (straight line length plus all turns) shown in "ACCA" manual "D".
- The air duct connector should be connected to the 3/4 "flange on the equipment. Install a flange around the air outlet.



If the duct connector has an elbow, its size should not be smaller than that of the flange on the outlet of the device.



The front flange on the return duct (if connected to the fan casing) must not be screwed into the area where the power cord is located. Drill bits or sharp screw tips can damage the insulation of the internal wires of the equipment.

- Use appropriate fasteners suitable for the type of duct used, fix the outlet and return ducts to the flanges of the device, and connect the ducts to the device with adhesive tape as needed to prevent air leakage.

## 7. Refrigerant Pipe Connection

Before the refrigerant pipe connection is completed, keep the coil sealed. Please refer to the installation, operation and maintenance manual of the external machine for detailed information on refrigerant line size, duct installation and filling amount.

Pull out the rubber plugs and check whether there is nitrogen flowing out.



### Warning: Personal injury hazard

- Failure to follow this warning could result in personal injury.
- Wear eye protection.



### Note:

- Factory nitrogen charge may escape past rubber plugs during storage. This does not indicate a leaking coil nor warrant return of the coil.

Care should be taken to connect the refrigerant pipe so that it will not obstruct the maintenance channel in front of the equipment.

Before brazing, the metal 1 and 2 need to be uninstalled. See Figure 7.1.

Pull out the evaporator (6 inches) so that longer refrigerant line could be exposed for wet rag and brazing.

During brazing, nitrogen should flow through the refrigerant pipe. Use a brazing shield to protect the paint of the cabinet, and use a wet rag to protect the rubber gasket of the pipeline from being damaged by the torch flame. During the brazing process, protect the temperature sensing bulb of TXV with wet cloth or approved heating paste. See Figure 7.1.

After brazing, pull in the evaporator and put the metal 1 and 2 back to the cabinet.

After the refrigerant pipeline connection is completed, seal and fill the surrounding gaps with pressure-sensitive gaskets.

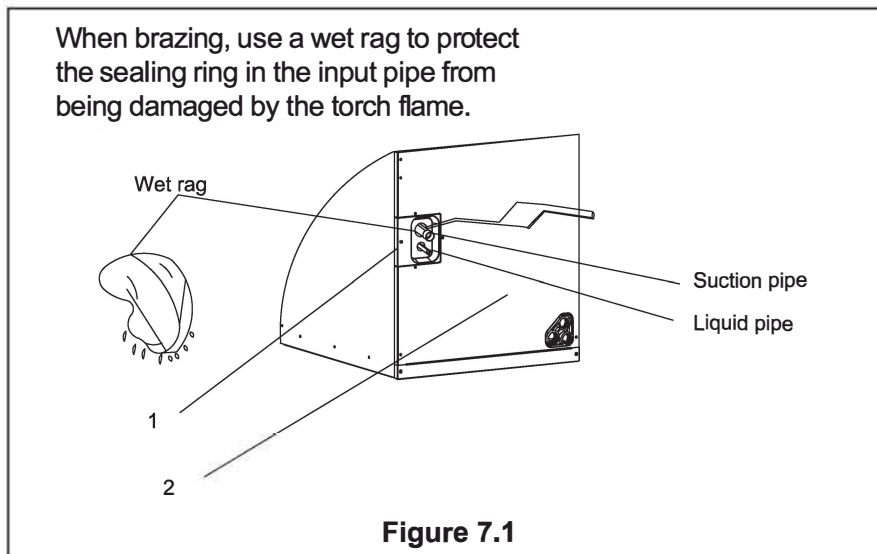



### Note: Maintain pressure with inert gas

- That after completion of field piping for split systems, the field pipework shall be pressure tested with an inert gas and then vacuum tested prior to refrigerant charging, The minimum test pressure for the system shall be the low side design pressure (See nameplate for detail).

After brazing, make sure that there is no refrigerant leakage. After checking the vapor leakage, make sure that the pipeline is insulated, as shown in Figure 7.2.

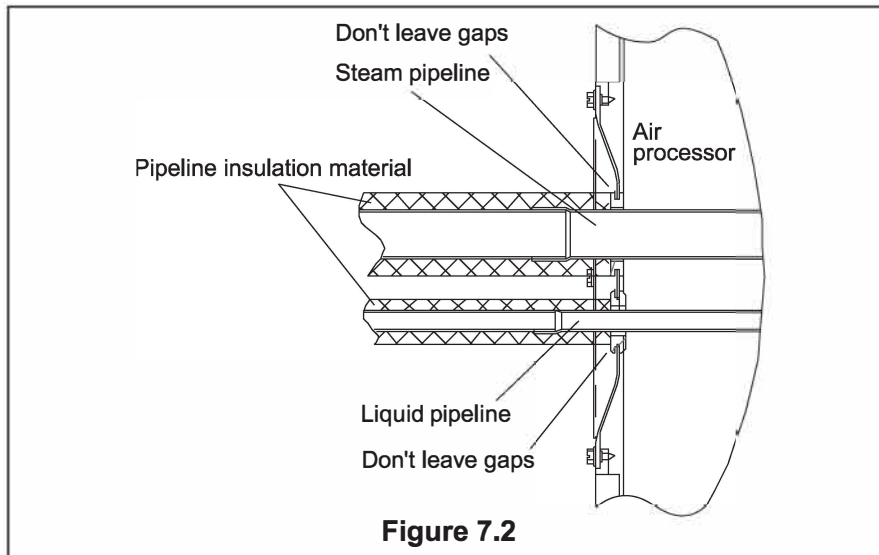
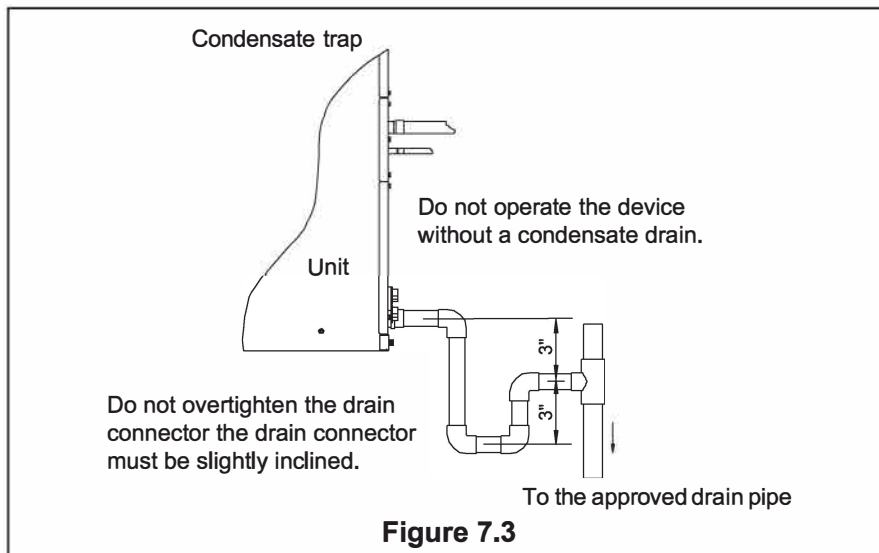

**Figure 7.2**

## 7.1 Condensate Drain Connection

For specific requirements, please consult local codes.

For the required condensate trap installation, please refer to Figure 7.3 and the following information.



**Figure 7.3**



1. When connecting the drain connector to the drain pan, use a thin layer of PTFE paste, silicone or PTEF, and tighten it by hand.
2. When connecting the drain connector to the drain pan, don't over tighten it. Tight fittings will crack the pipe connection on the drain pan.

- Make sure that the drainage pipe will not block the inlet in front of the device. The minimum clearance required for removal and maintenance of filter screen, coil or fan is 24 inches.
- Make sure that the machine is placed horizontally or slightly inclined to the main drain outlet, so that water can be completely drained from the machine.
- Do not reduce the drain pipe size to less than the connection size provided on the condensate drain pan.
- All horizontal drainage pipes must be inclined downward at a slope of at least 1/8 inch per foot to ensure proper drainage.
- Do not connect the condensate drain line to the closed or open sewage pipe. Drain the condensate to an open drainage pipe or to a safe outdoor area.
- Where necessary, the drainage pipeline should be insulated to prevent damage caused by condensation water formed on the outer surface of the pipeline.
- If necessary, be prepared to disconnect and clean the main drainage pipe. Install a 3-inch elbow on the main drainage pipe as close as possible to the unit. Make sure that the top of the elbow is lower than the joint of the drain pan to allow the drain pan to drain completely (see Figure 7.3).
- Auxiliary drainage pipes should be extended to places where condensate can be easily seen. If the condensed water starts to flow out from the auxiliary drain pipe, the homeowner should pay attention to the possible problems.
- Plug the unused drain connector with the plug in the parts package provided with the equipment. Use a thin layer of Teflon paste, silicone or Teflon tape to form a waterproof seal.
- After installation, test the condensate drain pan and drain pipe. Pour water into the drain pan, enough to fill the drain traps and pipes. Check to ensure that the drain pan completely drains water, no leakage is found in the drain pipe fittings, and water is discharged from the main drain pipe terminal.

## 8. Air Filter (Not Factory Installed)

The filter is not included in the device and must be provided on site.

The size of external filters or other filtering devices must meet the maximum flow rate of 300ft/min, or meet the recommended value of filter type.

The application and placement of filter is very important for airflow, which may affect the performance of heating and cooling system. Reduced airflow will shorten the life of the main components of the system, such as motors, components, thermal relays, evaporator coils or compressors. Therefore, we recommend that the return air duct system has only one filter position. For systems without return air filter grids, multiple filter grids can be installed at each return air opening.

If a high-efficiency filter screen or electronic air filtration system is used, it is very important that the air flow rate is not reduced. If the air flow decreases, the overall performance and efficiency of the device will decrease. It is strongly recommended to contact professional installation technicians to ensure the correct installation of such filtration systems.



Do not double filter the return air system. Do not filter the air supply duct system. This will change the performance of the device and reduce the airflow.



### Warning: Fire risk

- Do not operate the system without a filter. Part of the dust suspended in the air may temporarily stay on the duct and the air outlet of the room. Any circulating dust particles may be heated and burnt due to contact with AHU elements. This residue will stain the ceiling, walls, curtains, carpets and other items in the house. When some types of candles, oil lamps or igniters burn, soot may be generated in the filter.

## 9. Filter

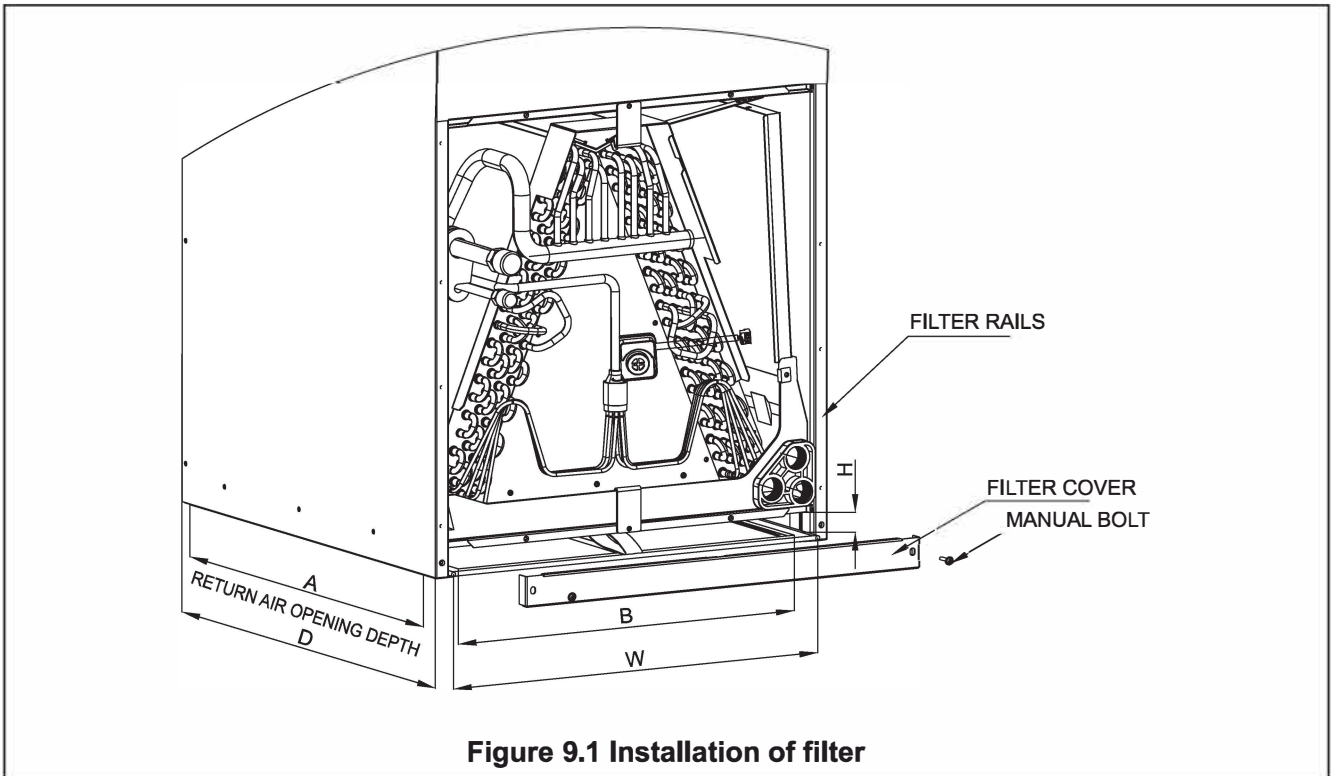

Filter is not included in the device and must be field supplied.



External filter or other means of filtration is required.

**Table 9.1 Size of Filter**

Model	Filter size inches [mm]	"W" Inch [mm]	"D" Inch [mm]	"H" Inch [mm]	Return Width "A" inch [mm]	Return Length "B" inch [mm]
18K/24K/30K/36K	18×20[457×508]	18.3 [466]	21.6 [548]	1 [25.4]	20.8 [528]	16.3 [414]
42K/48K/60K	20×22[508×559]	20.7 [526]	23.9 [608]	1 [25.4]	23 [584]	18.8 [478]

### Removal/Installation of Air Filter

- Manually remove the bolts and remove the filter cover, as shown in Figure 9.1.
- Hold the edge of the strainer and pull it out.
- Install a new filter so that the arrow on the filter screen is consistent with the airflow direction.
- If a reusable filter is used, please clean it according to the manufacturer's specifications before re-installing it.
- The filter needs to meet UL 900.

## 10. Maintenance



In order to keep high performance and minimize possible equipment failures, the equipment must be regularly maintained.

### 10.1 Cleaning Precautions



**Warning:**

- Any equipment maintenance can only be carried out by qualified maintenance personnel.



**Warning: Before cleaning and maintenance**

- Before cleaning or maintenance, be sure to turn off the equipment and disconnect its power supply.



**Be careful:**

- When removing the filter, do not touch the metal parts in the device. Sharp metal edges can cut you.



**Note:**

- Do not use chemicals or chemically treated cloth to clean the equipment.
- Do not use benzene, paint thinner, polishing powder or other solvents to clean this machine.
- Do not operate the system without a filter.

### 10.2 Routine Maintenance

Your equipment must be inspected regularly by qualified service technicians. Your annual system check must include:

1. Check the filter every 90 days, or at any time as needed. If it is blocked or block, please clean or replace it immediately.
2. Inspection and/or cleaning of impeller housing and motor.
3. Check and clean indoor and outdoor coils as needed.
4. Check and/or clean indoor coil drain pan and drain pipe and auxiliary drain pan and pipe.
5. Check all wires and connections. Refer to the wiring diagram and make corrections as needed.

## 11. Wiring Diagram



### Warning: Electric shock

- Before repairing or installing this device, please disconnect all power supplies. There may be multiple power sources. Otherwise, property damage, personal injury or death may result.



### Danger: Electric shock

- The device must be properly grounded and protected by a circuit breaker or fuse.



### Warning: Electric shock

- These devices must be wired and installed according to all national and local safety codes.

TERMINAL  
POWER OUT 230V/1ph/60Hz

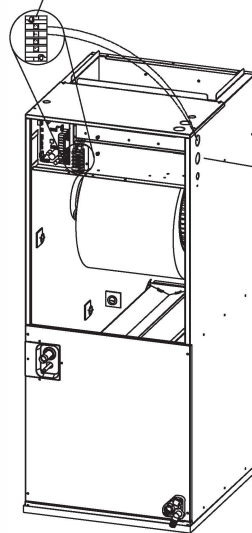

If you need to install the buzzer, please connect it according to the Figure 11.2. When the refrigerant leaks, the buzzer will receive the signal and respond in time. When the refrigerant concentration reaches the threshold, the indoor airflow will run at the highest gear and the outdoor unit will stop.

knockout hole

**Figure 11.1 Buzzer wiring diagram**

- To avoid electric shock, make sure:
  - 1) Equipment is properly grounded.
  - 2) The main power plug of the device has been connected to the ground wire (do not change it).
- Do not tighten the power cord.



The dotted line in the following thermostat wiring diagram indicates optional wiring (wiring for passive dehumidification function and/or electric heating). For the wiring of the thermostat, please refer to the user manual of the thermostat.

Wiring for 3H and 2C thermostat

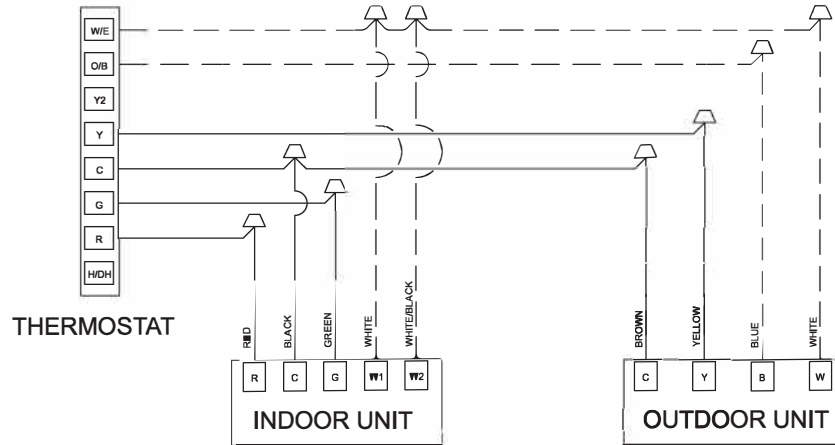

Figure 11.2 Control Wiring

Wiring for 4H and 2C thermostat

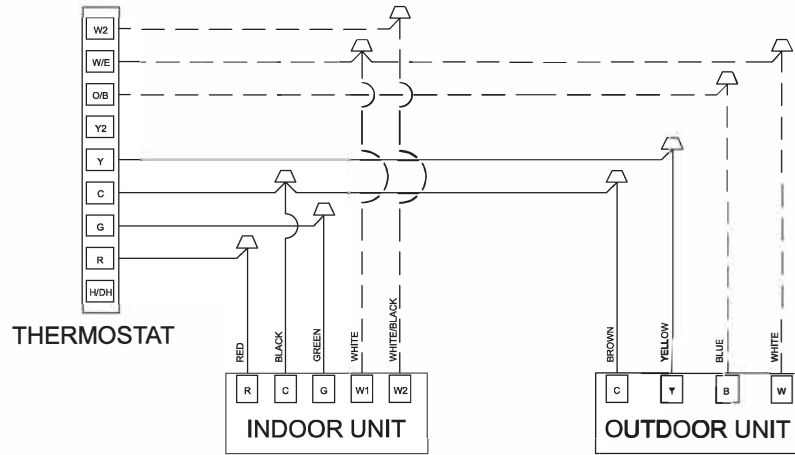

Figure 11.3 Control Wiring

Wiring for 3H and 1C thermostat

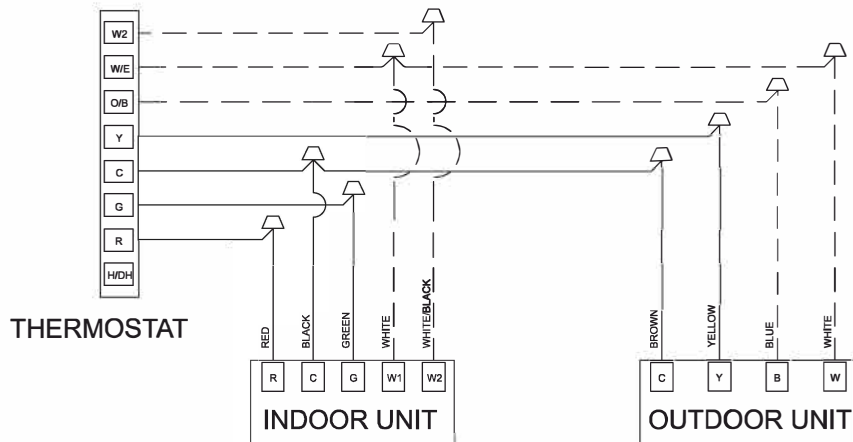

Figure 11.4 Control Wiring

Wiring for 2H and 2C thermostat

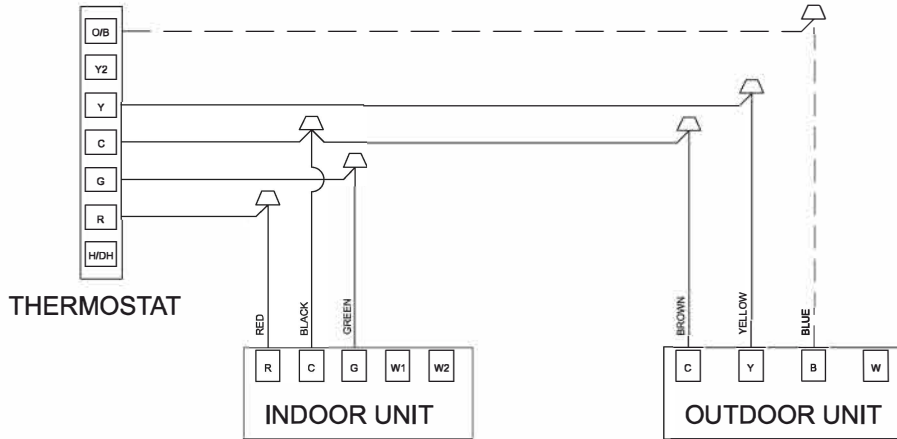

Figure 11.5 Control Wiring

Wiring for 1H and 1C thermostat

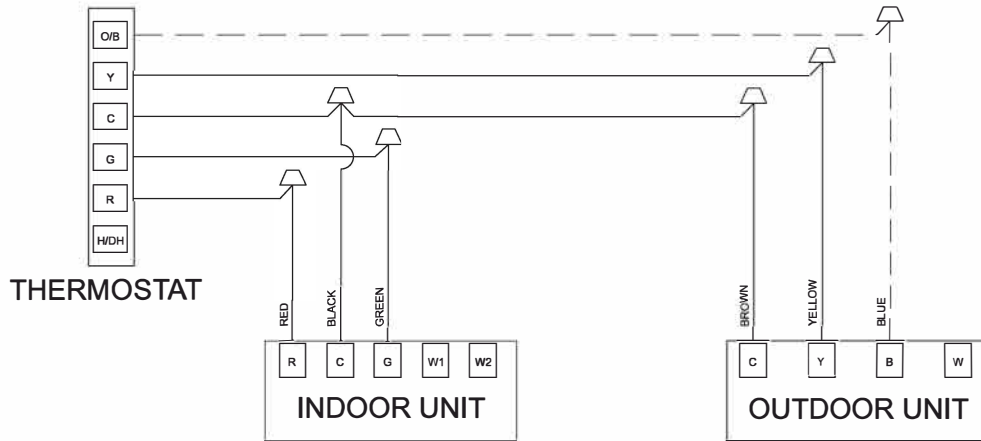

Figure 11.6 Control Wiring

Wiring for 2H and 1C thermostat

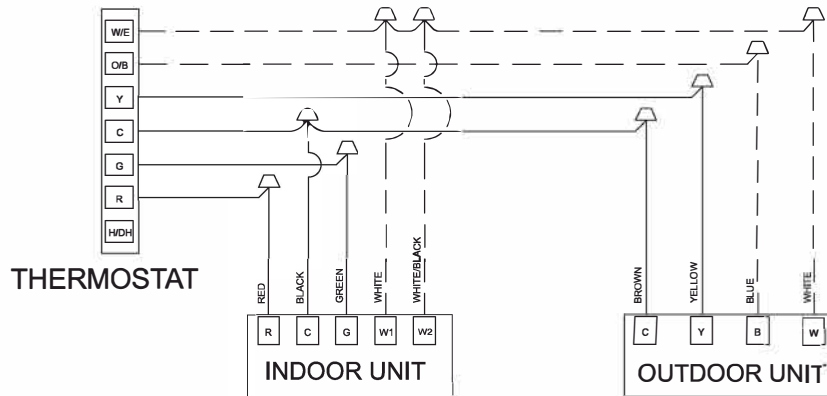

Figure 11.7 Control Wiring

**Table 11.1 LED Display Fault Code 18-36k**

	LED Status	System status
Model	LED light always on	Runing Mode
System warning	LED light 1 Flash/Cycle	R454B refrigerant leak Protection
	LED light 2 Flash/Cycle	Anti-freezed Protection
	LED light 3 Flash/Cycle	Evaporator Temperature Sensor Error
	LED light 4 Flash/Cycle	R454B refrigerant sensor Error
	LED light 5 Flash/Cycle	ECM motor Error

**Table 11.2 LED Display Fault Code 42-60k**

	LED Status	System status
Model	LED light always on	Runing Mode
	LED light 1 Flash/Cycle	Standby
System warning	LED light 2 Flash/Cycle	T1 sensor fault
	LED light 3 Flash/Cycle	T2 sensor fault
	LED light 4 Flash/Cycle	Refrigerant concentration sensor fault
	LED light 5 Flash/Cycle	Refrigerant leakage
	LED light 6 Flash/Cycle	Anti-freeze protection
	LED light 7 Flash/Cycle	Mainboard chip fault
	LED light 8 Flash/Cycle	Motor protection
	LED light 9 Flash/Cycle	IDU and ODU unit communication fault (RS485 communication mode)
	LED light 10 Flash/Cycle	Wire controller communication fault (RS485 communication mode)

**Table 11.3 Wire Gauge of High Voltage System**

Type (Btu/hour)		18K	24K	30K	36K	42K	48K	60K	
Power	Phase	Single							
	Voltage/frequency	208/230VAC, 60 Hz							
Wire gauge	Indoor unit power cord	Line quantity	3	3	3	3	3	3	3
		Wire diameter (AWG)	16	16	16	16	16	16	16
	Outdoor unit power cord	Line quantity	3	3	3	3	3	3	3
		Wire diameter (AWG)	14	14	12	12	10	10	10

Figure 11.8 wiring diagram 18-36k

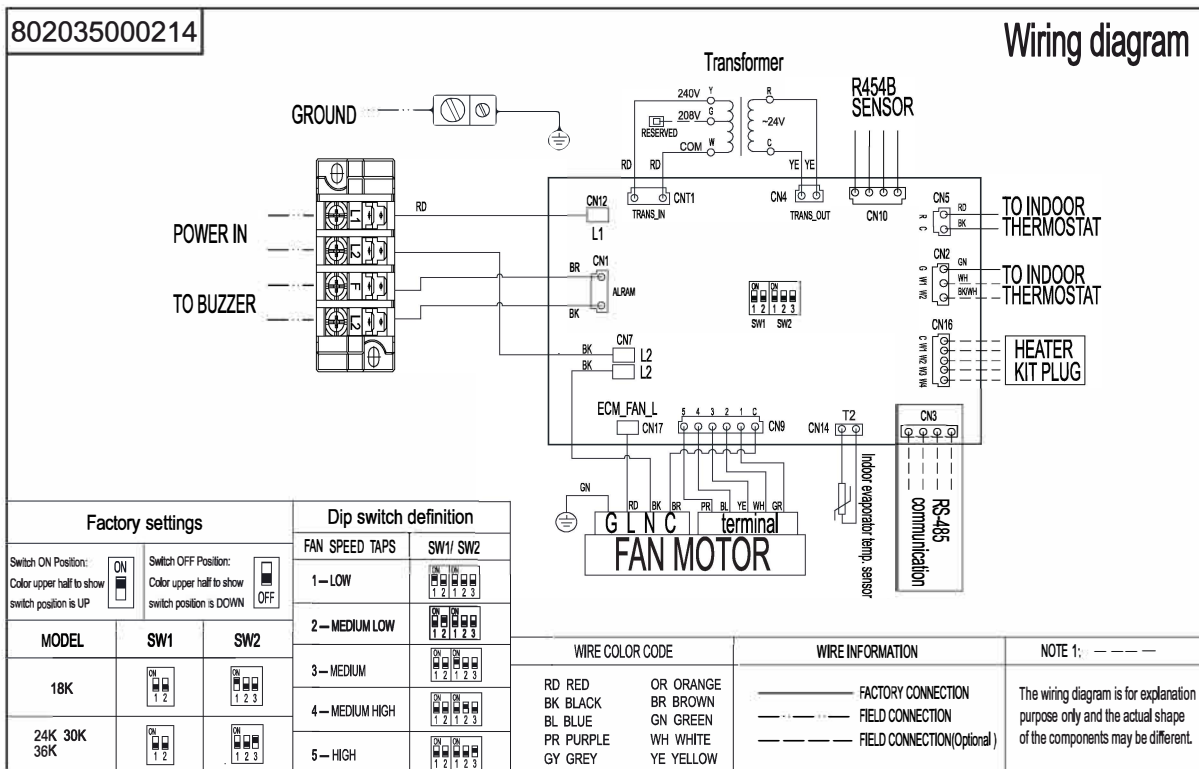

**NOTE:** Must set one of SW1 and SW2 Dip switch to ON. Please don't set all SW1 and SW2 Dip switch to OFF, otherwise, the Fan will not start on.  
For reference only, the actual wiring diagram shall prevail.

Figure 11.8 wiring diagram 42-60k

