

# ComfortStar®

Air Conditioning & Heating Products

## INSTALLATION INSTRUCTIONS

CPH7  
PACKAGED HEAT PUMP  
FEATURING R454B  
13.4 SEER2 (2-5 Tons)

CPH7-24-15 (30L)  
CPH7-30-15 (30M)  
CPH7-36-15 (30N)  
CPH7-42-15 (30P)  
CPH7-48-15 (30Q)  
CPH7-60-15 (30R)



Original instructions.  
Please read this manual carefully and keep it for future reference.  
All the pictures in this manual are for illustration purpose only.





Recognize this information symbol as an indication of important information.

## **⚠ WARNING**

These instructions are intended as an aid to qualified, licensed service personnel for proper installation, adjustment and operation of this unit. Read these instructions thoroughly before attempting installation or operation. Failure to follow these instructions may result in improper installation, adjustment, service or maintenance possibly resulting in fire, electrical shock, property damage, personal injury or death.

# **CONTENTS**

## **1 SAFETY**

- 1.1 Safety Signs ..... 01
- 1.2 Safety Precautions ..... 02

## **2 INSTALLATION**

- 2.1 Pre-Installation ..... 07
- 2.2 Clearance ..... 07
- 2.3 Rigging and Handling ..... 07
- 2.4 Location Restrictions ..... 13
- 2.5 Refrigerant Charge and Room Area Limitations ..... 14
- 2.6 Refrigerant Sensor ..... 17

## **3 AIRFLOW PERFORMANCE**

- 3.1 Airflow Performance Data ..... 18

## **4 DUCTWORK** ..... 21

## **5 CONDENSATE DRAIN CONNECTION**

- 5.1 Install Drain Pipe ..... 21

## **6 ABOUT THE AIR FILTER**

- 6.1 Air Filter (Not Factory-Installed) ..... 21

## **7 ELECTRICAL WIRING**

- 7.1 Power Wiring ..... 22
- 7.2 Grounding ..... 22
- 7.3 Control Wiring ..... 23

## **8 Electric Heater Kit**

- 8.1 Electric Heater Kit Electrical Data ..... 24
- 8.2 Electric Heater Kit Install Information ..... 25

## **9 SYSTEM OPERATION**

- 9.1 Compressor Crankcase Heater ..... 26
- 9.2 Reversing Valve ..... 26
- 9.3 Wind Pressure Switch ..... 26
- 9.4 Protection Function..... 26
- 9.5 LED Status ..... 27
- 9.6 Defrost Mode..... 27
- 9.7 Temperature Sensor Resistance Table..... 27
- 9.8 Thermostat Signals ..... 28

## **10 OPERATION CHECK-UP..... 28**

## **11 ERROR CODE AND TROUBLE SHOOTING**

- 11.1 Error Code of Module Board ..... 29
- 11.2 Error Code of Control Board(Only 42 K/48 K/60 K)..... 29
- 11.3 Troubleshooting Table ..... 30
- 11.4 Status Code..... 31
- 11.5 Parameter Point Check Table ..... 31

## **12 DISPOSAL ..... 35**

This document is customer property and is to remain with this unit.

These instructions do not cover all the different variations of systems nor does it provide for every possible contingency to be met in connection with installation.

All phases of this installation must comply with NATIONAL, STATE and LOCAL CODES. If additional information is required please contact your local distributor.

# 1 SAFETY

## 1.1 Safety Signs

### DANGER

indicates a hazardous situation which, if not avoided, will result in death or serious injury

### WARNING

indicates a hazardous situation which, if not avoided, could result in death or serious injury





### CAUTION

indicates a hazardous situation which, if not avoided, could result in minor or moderate injury

### NOTICE

is used to address practices not related to physical injury

## Explanation of symbols displayed on the unit

	<b>DANGER</b>	This symbol shows that this appliance uses a mild flammable refrigerant. If the refrigerant is leaked and exposed to an external ignition source, there is a risk of fire.
	<b>WARNING</b>	This symbol shows that the appliance shall be installed, operated and stored in a room with a floor area not less than the minimum room area.
	<b>CAUTION</b>	This symbol shows that the operation manual should be read carefully.
	<b>CAUTION</b>	This symbol shows that a service personnel should be handling this equipment with reference to the installation manual.
	<b>CAUTION</b>	This symbol shows that information is available such as the operating manual or installation manual.

## 1.2 Safety Precautions

### **⚠ WARNING**

These instructions are intended as an aid to qualified, licensed service personnel for proper installation, adjustment and operation of this unit. Read these instructions thoroughly before attempting installation or operation.

Failure to follow these instructions may result in improper installation, adjustment, service or maintenance possibly resulting in fire, electrical shock, property damage, personal injury or death.

### **⚠ WARNING**

The manufacturer's warranty does not cover any damage or defect to the heat pump caused by the attachment or use of any components, accessories or devices (other than those authorized by the manufacturer) into, onto or in conjunction with the heat pump. You should be aware that the use of unauthorized components, accessories or devices may adversely affect the operation of the heat pump and may also endanger life and property. The manufacturer disclaims any responsibility for such loss or injury resulting from the use of such unauthorized components, accessories or devices.

### **⚠ WARNING**

Disconnect all power to the unit before starting maintenance. Failure to do so can result in severe electrical shock or death.

### **⚠ WARNING**

Do not, under any circumstances, connect return ductwork to any other heat producing device such as a fireplace insert, stove, etc. Unauthorized use of such devices may result in fire, carbon monoxide poisoning, explosion, property damage, severe personal injury or death.

### **⚠ WARNING**

The unit must be permanently grounded. A grounding lug is provided. Failure to ground this unit can result in fire or electrical shock causing property damage, severe personal injury or death.

### **⚠ WARNING**

Only electric heater kits supplied by this manufacturer as described in this publication have been designed, tested, and evaluated by a nationally recognized safety testing agency for use with this unit. Use of any other manufactured electric heaters installed within this unit may cause hazardous conditions resulting in property damage, fire, body injury or death.

### **⚠ WARNING**

Proposition 65: This appliance contains fiberglass insulation. Respirable particles of fiberglass are known to the state of California to cause cancer.

### **⚠ WARNING**

Do not use means to accelerate the defrosting process or to clean, other than those recommended by the manufacturer.

The appliance shall be stored in a room that does not have continuously operating ignition sources (for example: open flames, an operating gas appliance or an operating electric heater).

Do not pierce/puncture refrigerant lines or bun the unit.

Be aware that refrigerants may not contain an odor.

### **⚠ WARNING**

Any person who is involved with working on or opening a refrigerant circuit should hold a current valid certificate from an industry-accredited assessment authority, which authorizes their competence to handle refrigerants safely in accordance with an industry recognized assessment credential.

Servicing shall only be performed as recommended by the equipment manufacturer.

Maintenance and repair requiring the assistance of other skilled personnel shall be carried out under the supervision of a person competent in the use of flammable refrigerants.

Prior to beginning work on systems containing flammable refrigerants, safety checks are necessary to minimize the risk of ignition.

### **⚠ WARNING**

#### **REFRIGERANT OIL**

These units use R454B refrigerant. Use only R454B approved service equipment. These units use a POE oil that readily absorbs moisture from the atmosphere. To limit this 'hygroscopic' action, the system should remain sealed whenever possible. If a system has been open to the atmosphere for more than 4 h, the compressor oil must be replaced. Never break a vacuum with air and always change the driers when opening the system for component replacement.

## **⚠ WARNING**

When repairing the refrigerating system, comply with the following precautions prior to conducting work on the system:

- shall be undertaken according to controlled procedures so as to minimize the risk of the presence of flammable gases or vapors while the work is being performed.

- All maintenance staff and others working in the local area shall be instructed on the nature of work being carried out. Work in confined spaces shall be avoided.

- The area shall be checked with an appropriate refrigerant detector prior to and during work, to ensure the technician is aware of potentially toxic or flammable environment.

Ensure that the leak detection equipment being used is suitable for use with all applicable refrigerants, i.e. non-sparking, adequately sealed or intrinsically safe.

- If any brazing/welding is to be conducted on the refrigerating equipment or any associated parts, appropriate fire extinguishing equipment shall be available and easily accessible. Have a dry powder or CO<sub>2</sub> fire extinguisher adjacent to the charging area.

- When carrying out work in relation to a refrigerating system that involves exposing any pipe work, no sources of ignition shall be used in such a manner that it may lead to the risk of fire or explosion.

All possible ignition sources, including cigarette smoking, should be kept sufficiently far away from the site of installation, repair, or removal and disposal of the unit, during which refrigerant can possibly be released into the surrounding space. Prior to beginning work, the area around the equipment is to be surveyed to make sure that there are no flammable hazards or ignition risks. "No Smoking" signs shall be clearly displayed.

Ensure that the area is in the open or that it is adequately ventilated before opening the system or conducting any hot work. A degree of ventilation shall continue during the period that the work is carried out. The ventilation should safely disperse any released refrigerant and preferably expel it externally into the surroundings.

Where electrical components are being changed, they shall be fit according to their purpose and to the correct specification. At all times the manufacturer's maintenance and service guidelines shall be followed. If in doubt, consult the manufacturer's technical department for assistance. The following checks shall be applied to installations using flammable refrigerants:

- The actual refrigerant charge is in accordance with the room size within which the refrigerant containing parts are installed.

- The ventilation machinery and outlets are operating adequately and are not obstructed.

- If an indirect refrigerating circuit is being used, the secondary circuit shall be checked for the presence of refrigerant.

- Equipment marking must remain visible and legible. Markings and signs that are illegible shall be corrected.

Refrigerating pipe or components are installed in a position where they are unlikely to be exposed to any substances which may corrode refrigerant containing components, unless the components are constructed of materials that are inherently resistant to corrosion or are suitably protected against corrosion.

Repair and maintenance of electrical components shall include initial safety checks and component inspection procedures. If a fault exists that could compromise safety, then no electrical supply shall be connected to the circuit until the fault has been dealt with satisfactorily.

If the fault cannot be corrected immediately but it is necessary to continue operation, an adequate temporary solution shall be used. This shall be reported to the owner of the equipment so that all parties are advised. Initial safety checks shall include:

- That capacitors are discharged: this shall be done in a safe manner to avoid the possibility of sparking.

- That no live electrical components and wiring are exposed while charging, recovering or purging the system.

- That there is continuity of proper grounding.

## **⚠ WARNING**

Sealed electrical components shall be replaced.

Intrinsically safe components must be replaced.

Check that cabling will not be subject to wear, corrosion, excessive pressure, vibration, sharp edges or any other adverse environmental effects. The check shall also take into account the effects of aging or continual vibration from sources such as compressors or fans.

Under no circumstances shall potential sources of ignition be used while searching for or detection of refrigerant leaks. A halide torch (or any other detector using a naked flame) shall not be used.

Electronic leak detectors may be used to detect refrigerant leaks but, in the case of flammable refrigerants, the sensitivity may not be adequate, or may need re-calibration. (Detection equipment shall be calibrated in a refrigerant-free area.) Ensure that the detector is not a potential source of ignition and is suitable for the refrigerant used. Leak detection equipment shall be set at a percentage of the LFL of the refrigerant and shall be calibrated for the refrigerant employed, and the appropriate percentage of gas (25 % maximum) is confirmed.

If a leak is suspected, all naked flames shall be removed/extinguished.

If a leakage of refrigerant which requires brazing is found, all of the refrigerant shall be recovered from the system, or isolated (by means of shut off valves) in a part of the system remote from the leak.

Leak detection fluids are also suitable for use with most refrigerants but the use of detergents containing chlorine shall be avoided as the chlorine may react with the refrigerant and corrode the copper pipe-work.

NOTE: Examples of leak detection fluids are

-bubble method,

When breaking into the refrigerant circuit to make repairs - or for any other purpose - conventional procedures shall be used. However, for flammable refrigerants it is important that best practices be followed, since flammability is a consideration. The following procedure shall be adhered to:

- safely remove refrigerant following local and national regulations.
- evacuate.
- purge the circuit with inert gas.
- evacuate.
- continuously flush or purge with inert gas when using flame to open circuit; and.
- open the circuit.

The refrigerant charge shall be recovered into the correct recovery cylinders if venting is not allowed by local and national codes. For appliances containing flammable refrigerants, the system shall be purged with oxygen-free nitrogen to render the appliance safe for flammable refrigerants. This process might need to be repeated several times. Compressed air or oxygen shall not be used for purging refrigerant systems.

For appliances containing flammable refrigerants, refrigerants purging shall be achieved by breaking the vacuum in the system with oxygen-free nitrogen and continuing to fill until the working pressure is achieved, then venting to atmosphere, and finally pulling down to a vacuum. This process shall be repeated until no refrigerant is within the system. When the final oxygen-free nitrogen charge is used, the system shall be vented down to atmospheric pressure to enable work to take place.

The outlet for the vacuum pump shall not be close to any potential ignition sources, and ventilation shall be available.

Ensure that contamination of different refrigerants does not occur when using charging equipment. Hoses or lines shall be as short as possible to minimise the amount of refrigerant they contain.

When use a refrigerant tank with siphon to add refrigerant, the refrigerant tank should be placed upright. When use a refrigerant tank without siphon to add refrigerant, the refrigerant tank should be placed upside down. Ensure that the refrigeration system is grounded prior to charging the system with refrigerant.

In general, R454B doesn't have a siphon tube or dip tube into tank. For this situation, they must be charged in liquid form to prevent fractionation of the blended refrigerant and that requires the jug to be inverted during charging.

Label the system when charging is complete (if it is not already labeled).

Take extreme care not to overfill the refrigeration system.

Prior to recharging the system, it shall be pressure-tested with the appropriate purging gas. The system shall be leak-tested on completion of charging but prior to commissioning. A follow up leak test shall be carried out prior to leaving the site.

Before carrying out this procedure, it is essential that the technician is completely familiar with the equipment and all its detail. It is recommended that all refrigerants are recovered safely. Prior to the task being carried out, an oil and refrigerant sample shall be taken in case analysis is required prior to re-use of reclaimed refrigerant. It is essential that electrical power is available before the task is commenced.

a) Become familiar with the equipment and its operation.

b) Isolate system electrically.

c) Before attempting the procedure ensure that:

– mechanical handling equipment is available, if required, for handling refrigerant cylinders;

– all personal protective equipment is available and being used correctly;

– the recovery process is supervised at all times by a competent person;

– recovery equipment and cylinders conform to the appropriate standards.

d) Pump down refrigerant system, if possible.

e) If a vacuum is not possible, make a manifold so that refrigerant can be removed from various parts of the system.

f) Make sure that the cylinder is situated on the scales before recovery takes place.

g) Start the recovery machine and operate it in accordance with the manufacturer's instructions.

h) Do not overfill cylinders. (No more than 80% volume liquid charge).

i) Do not exceed the maximum working pressure of the cylinder, even temporarily.

j) When the cylinders have been filled correctly and the process has been completed, make sure that the cylinders and the equipment are removed from site promptly and all isolation valves on the equipment are closed off.

k) Recovered refrigerant shall not be charged into another refrigeration system unless it has been cleaned and checked.

Equipment shall be labeled stating that it has been de-commissioned and emptied of refrigerant. The label shall be dated and signed. Ensure that there are labels on the equipment stating the equipment contains flammable refrigerant.

When removing refrigerant from a system, either for servicing or decommissioning, it is recommended that all refrigerants are removed safely.

When transferring refrigerant into cylinders, ensure that only appropriate refrigerant recovery cylinders are employed. Ensure that the correct number of cylinders for holding the total system charge is available. All cylinders to be used are designated for the recovered refrigerant and labelled for that refrigerant (i.e. special cylinders for the recovery of refrigerant). Cylinders shall be complete with pressure-relief valve and associated shut-off valves in good working order. Empty recovery cylinders are evacuated and, if possible, cooled before recovery occurs.

The recovery equipment shall be in good working order with a set of instructions concerning the equipment that is at hand and shall be suitable for the recovery of the flammable refrigerant. If in doubt, the manufacturer should be consulted. In addition, a set of calibrated weighing scales shall be available and in good working order. Hoses shall be complete with leak-free disconnect couplings and in good condition.

The recovered refrigerant shall be processed according to local legislation in the correct recovery cylinder, and the relevant waste transfer note arranged. Do not mix refrigerants in recovery units and especially not in cylinders.

If compressors or compressor oils are to be removed, ensure that they have been evacuated to an acceptable level to make certain that flammable refrigerant does not remain within the lubricant. The compressor body shall not be heated by an open flame or other ignition sources to accelerate this process. When oil is drained from a system, it shall be carried out safely.

Do not use the air conditioner for other purposes.

In order to avoid any quality deterioration, do not use the unit for the cooling of precision instruments, food, plants, animals or works of art.

Before cleaning, be sure to stop the operation, turn the breaker off or unplug the supply cord. Otherwise, electric shock and injury may occur.

In order to avoid electric shock or fire, make sure that an earth ground detector is installed.

Never touch the air outlet or the horizontal blades while the swing flap is in operation. Your fingers may become caught or the unit may break down.

Never put any objects into the air inlet or outlet.

Objects touching the fan at high speed can be dangerous.

Never inspect or service the unit by yourself.

Ask a qualified service person to perform this task.

Do not dispose of this product as unsorted municipal waste. This waste should be collected separately for special treatment.

Do not dispose of electrical appliances as unsorted municipal waste. Use separate collection facilities. Contact your local government for information regarding the connection systems available.

If electrical appliances are disposed of in landfills or dumps, hazardous substances can leak into the groundwater and get into the food chain, harming your health and well-being.

To prevent refrigerant leak, contact your dealer.

When the system is installed and operates in a small room, it is required to maintain the concentration of the refrigerant below the limit, in case a leak occurs. Otherwise, oxygen in the room may be affected, resulting in a serious accident.

The refrigerant in the air conditioner is safe and normally does not leak.

If the refrigerant leaks into the room and comes into contact with the fire of a burner, a heater or a cooker, a harmful gas could be released.

Turn off any combustible heating devices, ventilate the room, and contact the dealer where you purchased the unit.

Do not use the air conditioner until a service person confirms that the refrigerant leak is repaired.

Keep ventilation openings clear of obstruction.

## **⚠ CAUTION**

Be sure the air conditioner is grounded. In order to avoid electric shock, make sure that the unit is grounded and that the ground wire is not connected to a gas or water pipe, lightning conductor or telephone ground wire.

Do not operate the air conditioner with a wet hands. An electric shock may happen.

Do not operate the air conditioner when using a room fumigation-type insecticide. Failure to observe this precaution could cause the chemicals to become deposited in the unit, which could endanger the health of those who are hypersensitive to chemicals. It may also cause the refrigerant sensor to alarm.

To avoid oxygen deficiency, ventilate the room sufficiently if equipment with a burner is used together with the air conditioner.

Arrange the drain hose to ensure smooth drainage. Incomplete drainage may cause damage to the building, furniture, etc.

Never touch the internal parts of the controller. Do not remove the front panel. Some parts inside are dangerous to touch, and machine troubles may occur.

Attention is drawn to the fact that additional transportation regulations may exist with respect to equipment containing flammable gas. The maximum number of pieces of equipment or the configuration of the equipment permitted to be transported together will be determined by the applicable transport regulations.

Signs for similar appliances used in a work area are generally addressed by local regulations and give the minimum requirements for the provision of safety and/or health signs for a work location.

Storage package protection should be constructed such a way that mechanical damage to the equipment inside the package will not cause a leak of the refrigerant charge.

The maximum number of pieces of equipment permitted to be stored together will be determined by local regulations.

All required signs are to be maintained and employers should ensure that employees receive suitable and sufficient instruction and training on the meaning of appropriate safety signs and the actions that need to be taken in connection with these signs.

The effectiveness of signs should not be diminished by too many signs being placed together.

Any pictograms used should be as simple as possible and contain only essential details.

The storage of the appliance should be in accordance with the applicable regulations or instructions, whichever is more stringent.

Do not place appliances which produce open flame in places exposed to the air flow from the unit or under the indoor unit. It may cause incomplete combustion or deformation of the unit due to the heat.

Do not install the air conditioner in a location where flammable gas may leak out. If the gas leaks out and stays around the air conditioner, a fire may break out.

## ⚠ WARNING

The appliance uses R454B refrigerant.



## ⚠ WARNING

These instructions are exclusively intended for qualified contractors and authorized installers.

Work on the refrigerant circuit with mild flammable refrigerant in safety group A2L may only be carried out by authorized heating contractors. These heating contractors must be trained in accordance with UL 60335-2-40, Section HH. The certificate of competence from an industry accredited body is required.

Work on electrical equipment may only be carried out by a qualified electrician.

Before initial commissioning, all safety – related points must be checked by the particular certified heating contractors. The system must be commissioned by the system installer or a qualified person authorized by the installer.

## ⚠ CAUTION

Only use this unit in well-ventilated spaces and ensure that there are no obstructions that could impede the airflow into and out of the unit.

Do not use this unit in the following locations:

- Locations with mineral oil.
- Locations with saline atmospheres, such as seaside locations.
- Locations with sulphurous atmospheres, such as near natural hot springs.
- Where high voltage electricity is present, such as in certain industrial locations.
- On vehicles or vessels, such as trucks or ferry boats.
- Where exposure to oily or very humid air may occur, such as kitchens.
- In proximity to sources of electromagnetic radiation, such as high-frequency transmitters or other high strength radiation devices.

## ⚠ CAUTION

A manufactured (mobile) home installation must conform with the Manufactured Home Construction and Safety Standard, Title 24 CFR, Part 3280, or when this Standard is not applicable, the Standard for Manufactured Home Installations (Manufactured Home Sites, Communities and Set-Ups), ANSI/NCS A225.1, and/or MH Series Mobile Homes, CAN/CSA Z240.

## ⚠ CAUTION

This appliance is not intended for use by persons (including children) with reduced physical, sensory or mental capabilities, or lack of experience and knowledge, unless they have been given supervision or instruction concerning use of the appliance by a person responsible for their safety.

Children should be supervised to ensure that they do not play with the appliance.

## 2 INSTALLATION

### ⚠ WARNING

Ensure the unit is mounted securely.

### ⚠ WARNING

The pipe-work including piping material, pipe routing, and installation shall include protection from physical damage in operation and service, and be in compliance with national and local codes and standards, such as ASHRAE 15, ASHRAE 15.2, IAPMO Uniform Mechanical Code, ICC International Mechanical Code. Inspection prior to being covered or enclosed, or CSA B52. All field joints shall be accessible for inspection prior to being covered or enclosed.

### 2.1 Pre-Installation

#### ⚠ WARNING

The appliance shall be stored so as to prevent mechanical damage from occurring.

Before installation, carefully check the following:

1. Unit should be installed in accordance with national and local safety codes, including but not limit to ANSI/NFPA No. 70 or Canadian Electrical Code Part 1, C22.1, local plumbing and wastewater codes and any other applicable codes.
2. For rooftop installation, be sure the structure has enough strength to support the weight of unit. Unit should be installed on roof curb and leveled.
3. For ground level installation, a level slab should be used.
4. Condenser airflow should not be restricted.
5. On applications when a roof curb is used, the unit must be positioned on the curb so the front of the unit is tight against the curb.

#### ⚠ CAUTION

As soon as unit is received, it should be inspected and noted for possible shipping damage during transportation. It is carrier's responsibility to cover the cost of shipping damage. Manufacturer or distributor will not accept the claims from dealer for any transportation damage.

### 2.2 Clearance

All units require certain clearance for proper operation and service. Refer to Table 2-1 for the clearances required for construction, servicing and proper unit operation.

Refer to Fig. 2-3, 2-4, 2-5, 2-6 for unit physical data and to nameplate for electrical data. If components are to be added to a unit that must meet local codes, they are to be installed at the dealer's and /or the customer's expense.

Size of unit for proposed installation should be based on heat loss / heat gain calculations made in accordance with industry recognized procedures identified by the Air Conditioning Contractors of America.

### 2.3 Rigging and Handing

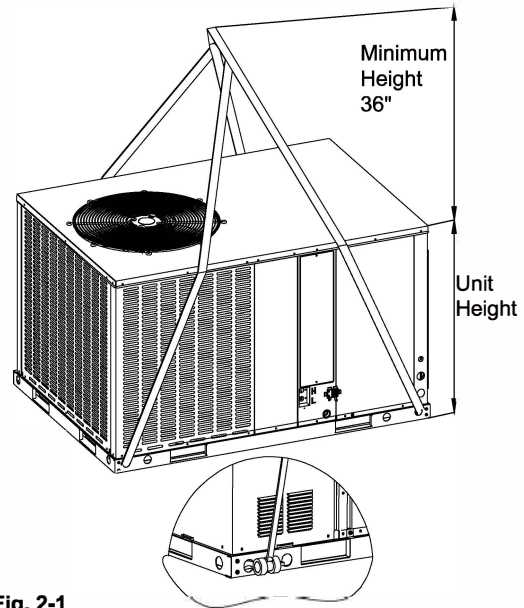

Fig. 2-1

Exercise care when moving the unit. Do not remove any packaging until the unit is near the place of installation. Rig the unit by attaching chain or cable slings to the lifting holes provided in the base rails. Spreader bars, whose length exceeds the largest dimension across the unit, MUST be used across the top of the unit.

#### ⚠ CAUTION

Before lifting, make sure the unit weight is distributed equally on the rigging cables so it will lift evenly.

Units may be moved or lifted with a forklift. Slotted openings in the base rails are provided for this purpose.

#### ⚠ CAUTION

All panels must be secured in place when the unit is lifted. The condenser coils should be protected from rigging cable damage with plywood or other suitable material.

#### ⚠ WARNING

Check the electric wire, water and gas pipeline layout inside the wall, floor and ceiling before installation. Do not implement drilling unless confirm safety with the user, especially for the hidden power wire. An electroprobe can be used to test whether a wire is passing by at the drilling location, to prevent physical injury or death caused by insulation broken cords.

#### ⚠ WARNING

Check the power supply before installation. Ensure that the power supply must be reliably grounded following local, state and National Electrical Codes. If not, for example, if the ground wire is detected charged, installation is prohibited before it is rectified. Otherwise, there is a risk of fire and electric shock, causing physical injury or death.

For 2 ton to 3 ton unit

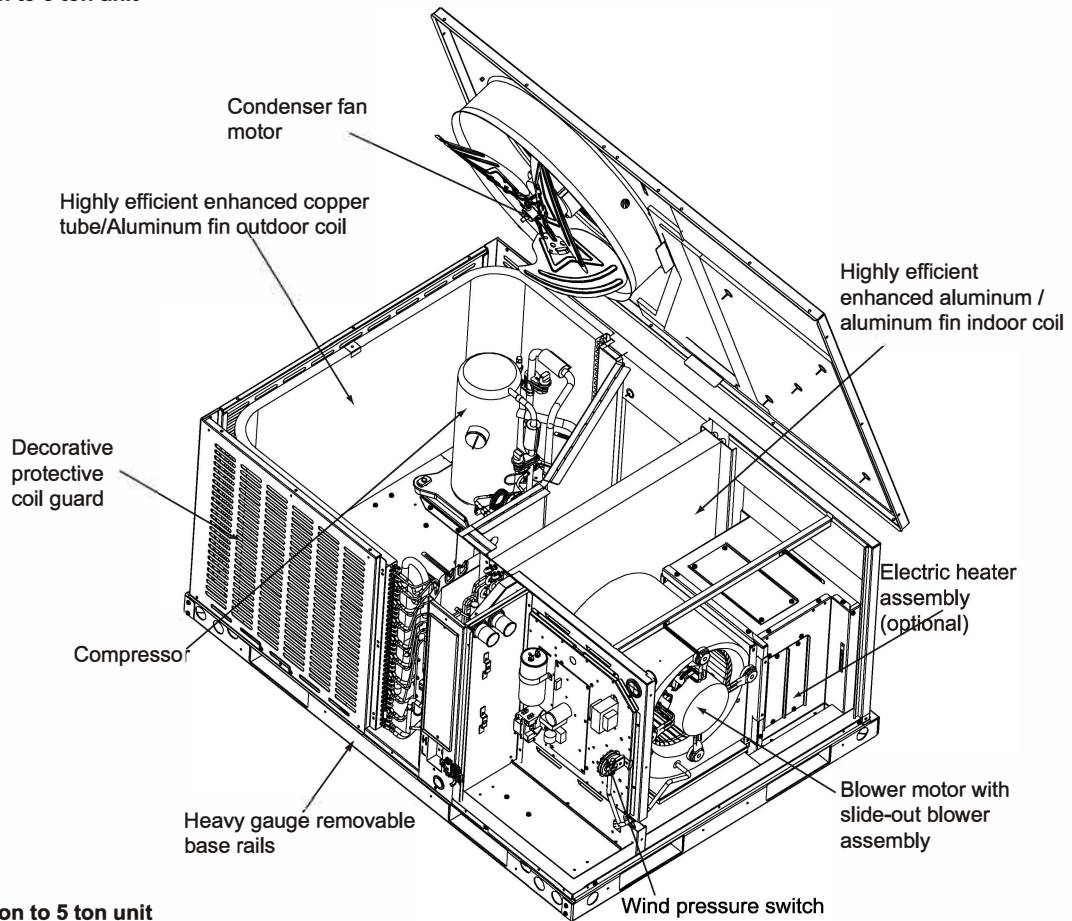

For 3.5 ton to 5 ton unit

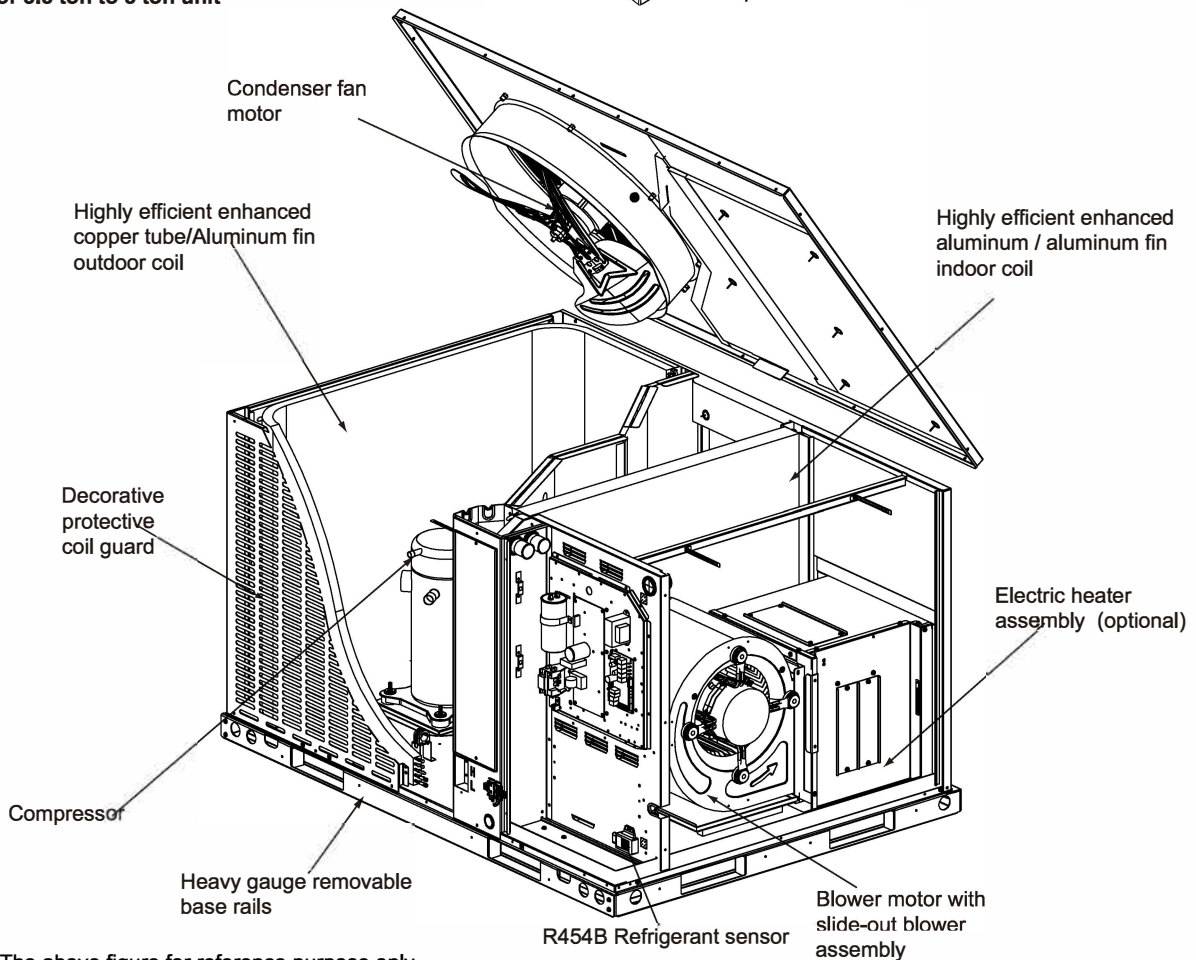

\* The above figure for reference purpose only.

Fig. 2-2 Component Location

For 2 ton to 3 ton unit

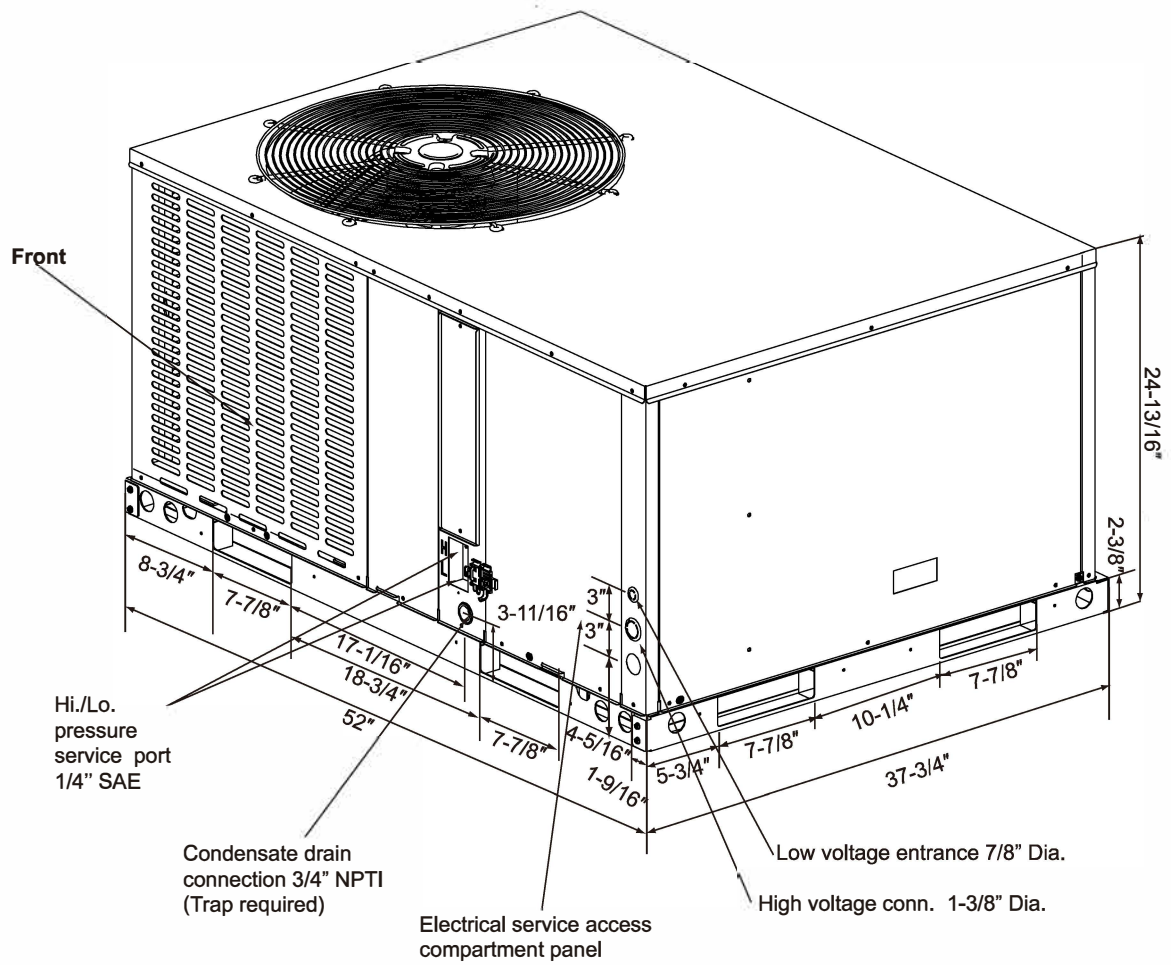

Fig. 2-3 Unit Dimensions

\* The above figure for reference purpose only.

For 2 ton to 3 ton unit

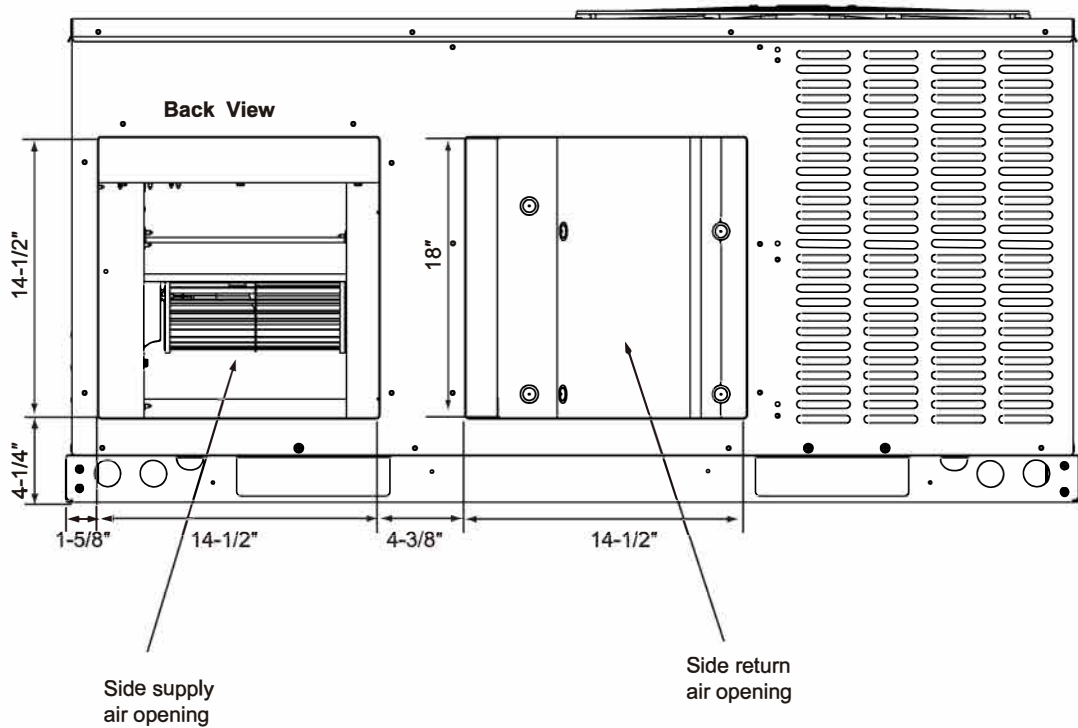
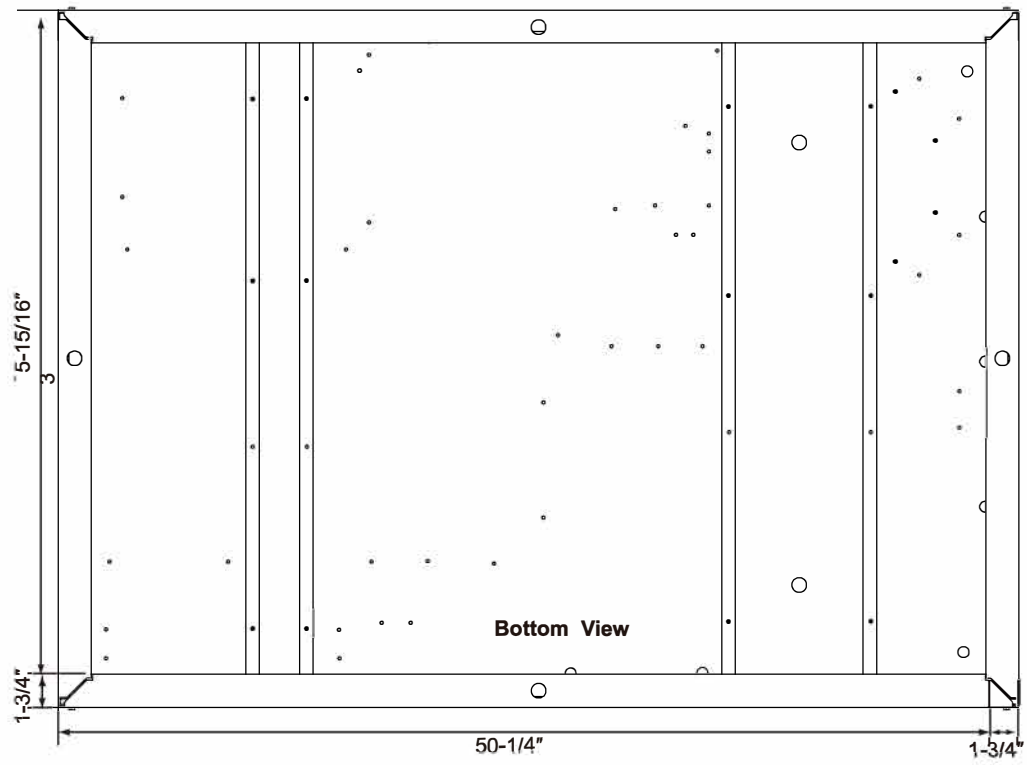

Fig. 2-4 Dimensions Back and Bottom

\* The above figure for reference purpose only.

For 3.5 ton to 5 ton unit

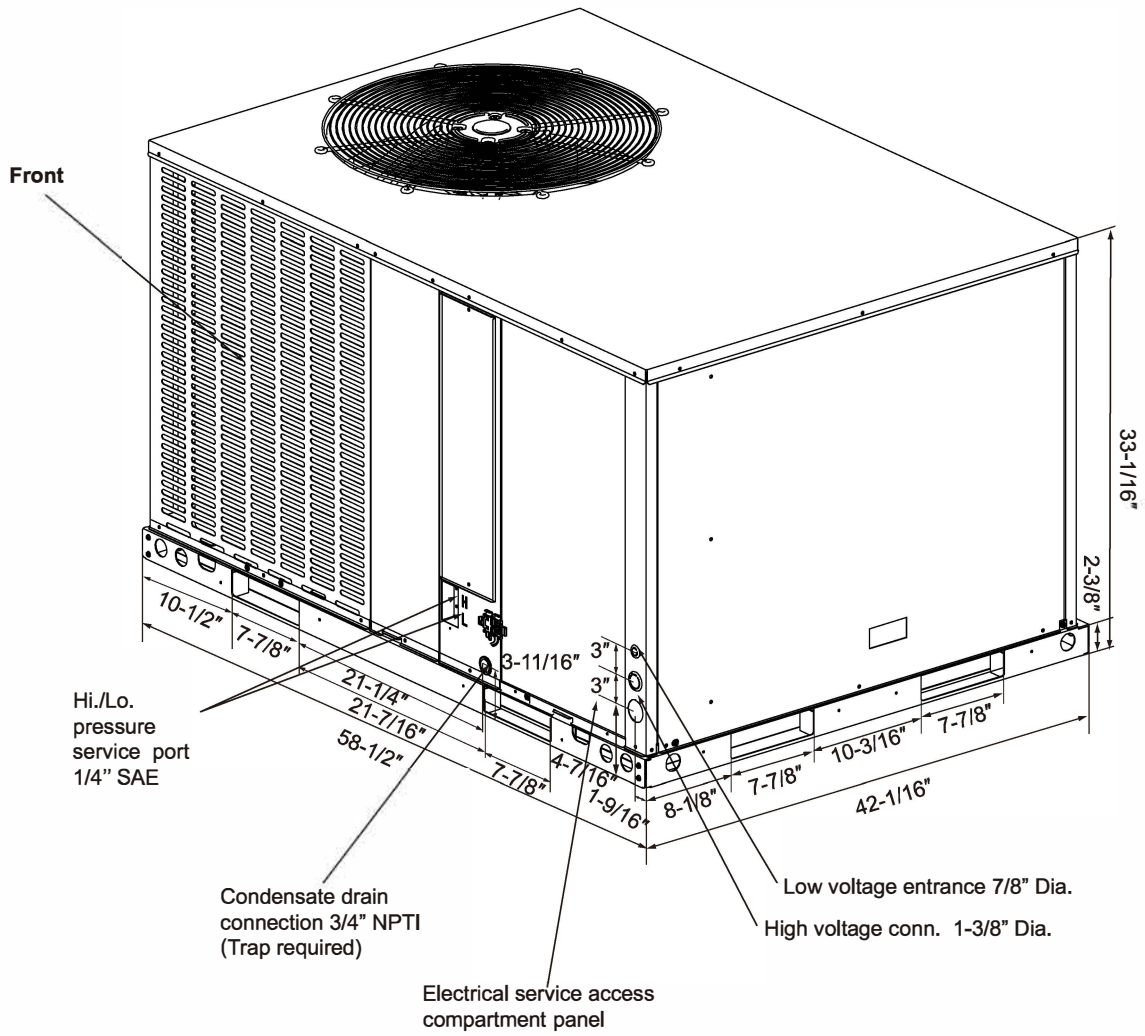

Fig. 2-5 Unit Dimensions

\* The above figure for reference purpose only.

For 3.5 ton to 5 ton unit

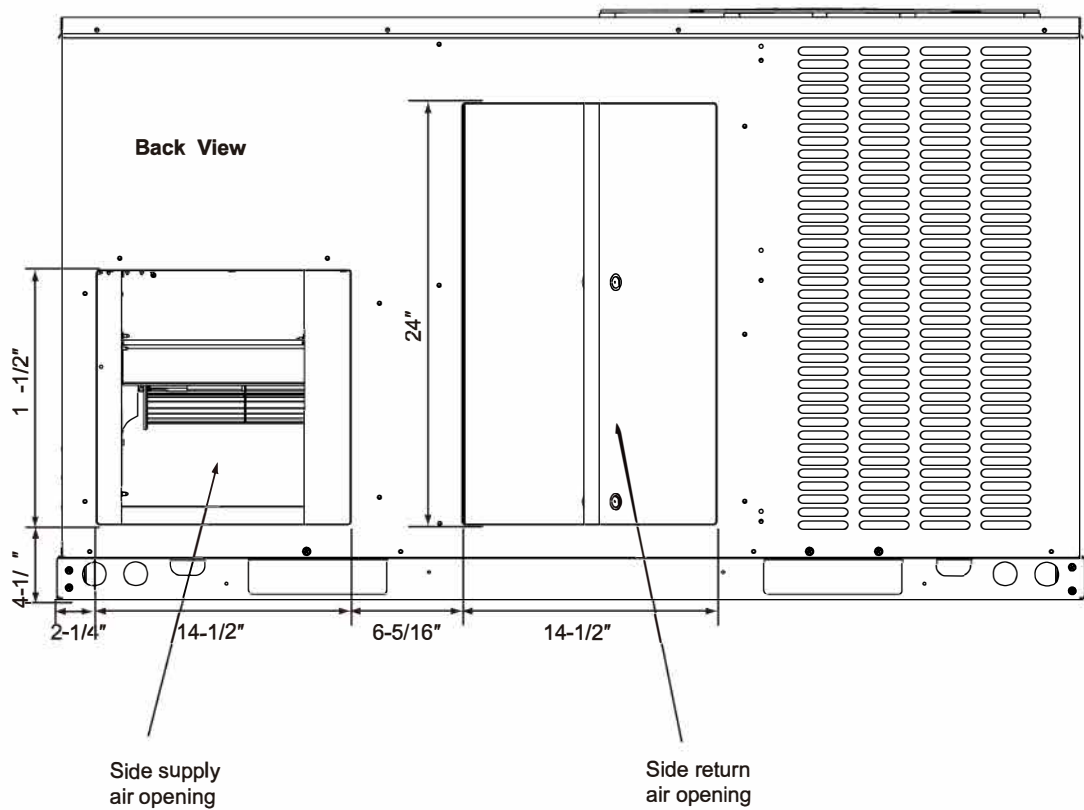
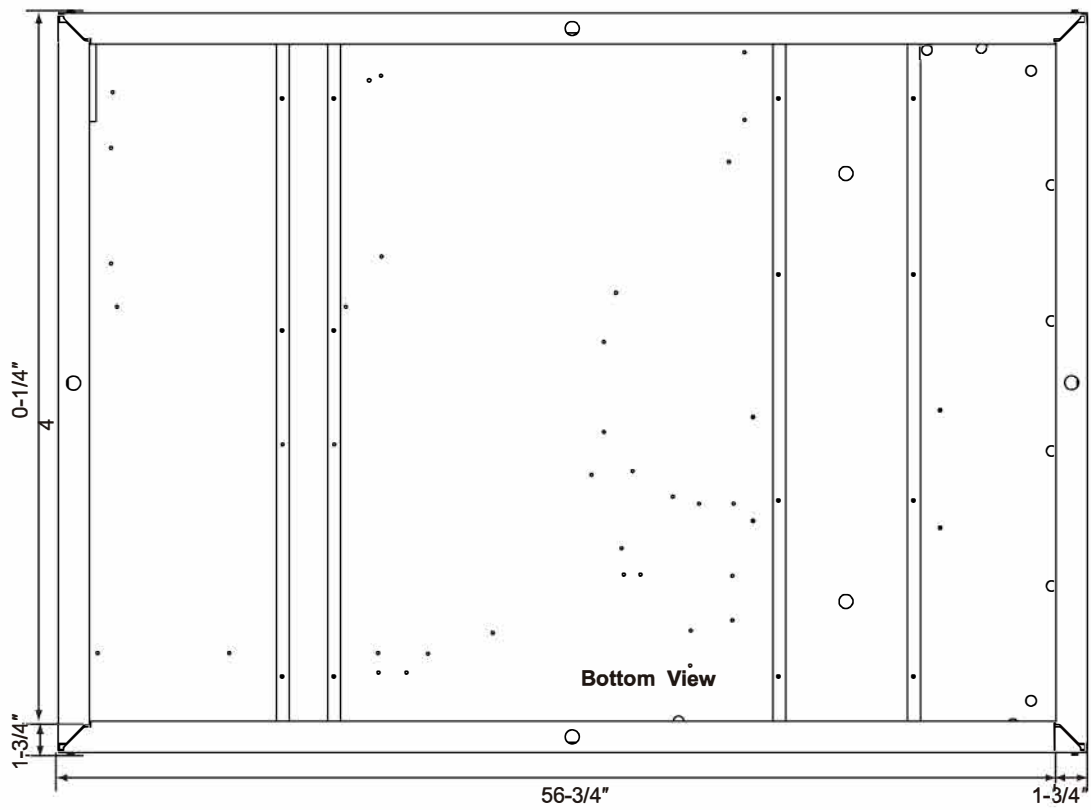

Fig. 2-6 Dimensions Back and Bottom

\* The above figure for reference purpose only.

Table 2-1: Unit Clearance

Direction	Distance (in.)	Direction	Distance (in.)
Top <sup>1</sup>	60	Right	30
Front	30	Left	24
Rear	18 <sup>2</sup>	Bottom <sup>3</sup>	0

Duct clearance: 1 inch clearance for all sides of air supply duct.

1. Units must be installed outdoors. Over hanging structure or shrubs should not obscure condenser air discharge outlet.
2. The minimum clearance without economizer/fresh air damper. For distance with economizer/fresh air damper, please refer to the installation instructions provided with the accessory.
3. Units may be installed on combustible floors made from wood or class A, B or C roof covering materials.

### NOTICE

For units applied with a roof curb, the minimum clearance may be reduced from 1 inch to 1/2 inch between combustible roof curb material and this supply air duct.

### NOTICE

A unit with electric heaters with an inlet or outlet duct that penetrates the building structure supporting the unit shall be provided with a mounting base of noncombustible material so designed that, after the unit is installed, there will be no open passages through the supporting structure that would permit flame or hot gases from a fire originating in the space below the supporting structure to travel to the space above that structure. If the unit is intended to be installed on a supporting structure of combustible material, the base shall be so designed that the required clearance will be maintained between the supporting structure and the unit, plenum, and attached duct. Spacers necessary to provide required clearances shall be attached to the unit mounting base, and shall extend not less than 76 mm (3 in.) below the upper surface of the supporting structure, except that, in a unit designed for use only in a mobile home, the distance shall be not less than 19 mm (3/4 in.).

### NOTICE

Make sure that Condensate Drain side is not higher than the other side.

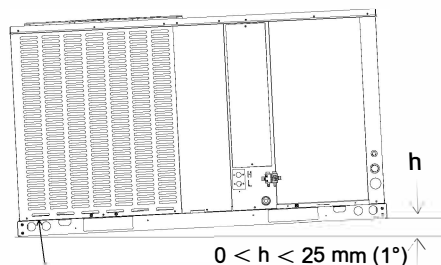

Condensate drain side

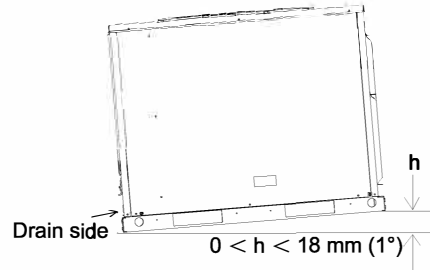

Fig. 2-7

## 2.4 Location Restrictions

Ensure the top discharge area is unrestricted for at least 60 inches above the unit.

Do not locate outdoor unit near bedrooms since normal operational sounds may be objectionable.

Position unit to allow adequate space for unobstructed airflow, wiring, refrigerant lines, and serviceability.

Allow a minimum of 12 in. clearance on one side of access panel to a wall and a minimum of 24 in. on the adjacent side of access panel.

Maintain a distance of 24 in. between units.

Position unit where water, snow, or ice from roof or overhang cannot fall directly on unit.

See Fig. 2-8 and Fig. 2-9.

Cold climate considerations

### NOTICE

Precautions must be taken for units being installed in areas where snow accumulation and prolonged below-freezing temperatures occur.

- Units should be elevated 3-12 inches above the pad or rooftop, depending on local weather. This additional height will allow drainage of snow and ice melted during defrost cycle prior to its refreezing. Ensure that drain holes in unit base pan are not obstructed, preventing drainage of defrost water (Fig. 2-9).
- If possible, avoid locations that are likely to accumulate snow drifts. If not possible, a snow drift barrier should be installed around the unit to prevent a build-up of snow on the sides of the unit.

Avoid Install Near Bedrooms

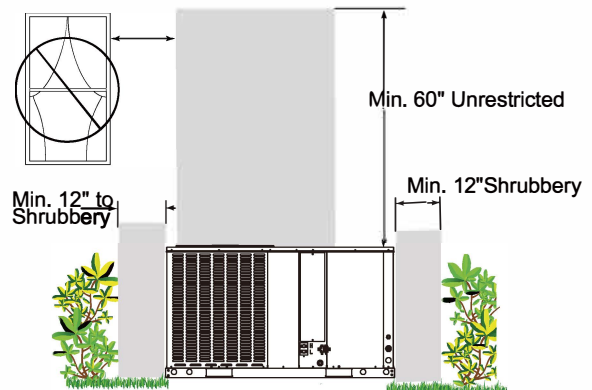

Fig. 2-8

## 2.5 Refrigerant Charge and Room Area Limitations

In UL/CSA 60335-2-40, R454B refrigerant is classified as class A2L, which is mildly flammable. Therefore, R454B refrigerant will limit the area of the rooms being served by the system.

Similarly, the total amount of refrigerant in the system shall be less than or equal to the allowable maximum refrigerant charge. The allowable maximum refrigerant charge depends on the area of the rooms being served by the system.

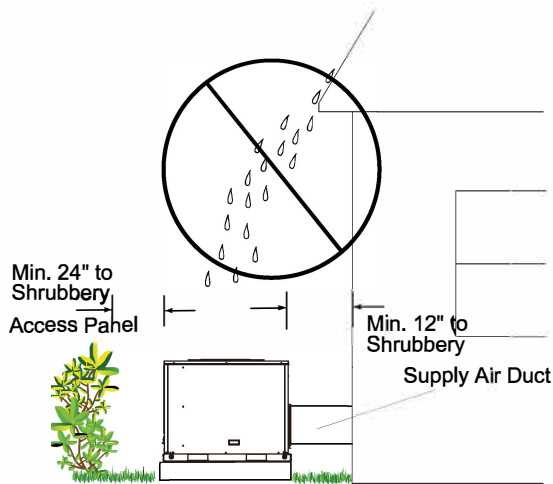

Fig. 2-9

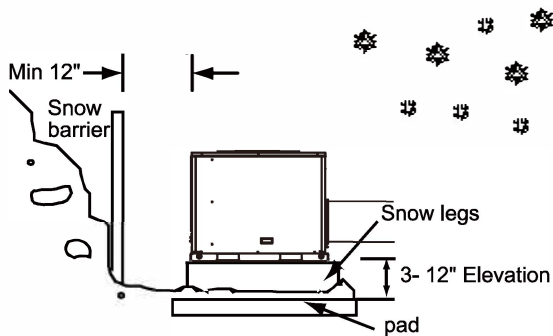

Fig. 2-10

### NOTICE

The abbreviations in this section are explained as follows:

$m_c$ : The actual refrigerant charge in the system.  
 $A$ : the actual room area where the appliance is installed.

$A_{min}$ : The required minimum room area.

$m_{max}$ : The allowable maximum refrigerant charge in a room.

$Q_{min}$ : The minimum circulation airflow.

$Anv_{min}$ : The minimum opening area for connected rooms.

$TA_{min}$ : The required minimum total area of the conditioned space (For appliances serving two or more rooms with an air duct system).

$TA$ : The total area of the conditioned space connected by air ducts. For appliances serving two or more rooms with an air duct system.

### 2.4.1 The room area calculation requirements

### CAUTION

The space considered shall be any space which contains refrigerant-containing parts or into which refrigerant could be released.

The room area ( $A$ ) of the smallest, enclosed, occupied space shall be used in the determination of the refrigerant quantity limits.

For determination of room area ( $A$ ) when used to calculate the refrigerant charge limit, the following shall apply.

The room area ( $A$ ) shall be defined as the room area enclosed by the projection to the base of the walls, partitions and doors of the space in which the appliance is installed.

Spaces connected by only drop ceilings, ductwork, or similar connections shall not be considered a single space.

Units mounted higher than 70-55/64 inches and spaces divided by partition walls that are no higher than 62-63/64 inches shall be considered a single space.

Rooms on the same floor and connected by an open passageway between the spaces can be considered a single room when determining compliance to  $A_{min}$ , if the passageway complies with all of the following.

- 1) It is a permanent opening.
- 2) It extends to the floor.
- 3) It is intended for people to walk through.

The area of the connected rooms, on the same floor, connected by permanent opening in the walls and/or doors between occupied spaces, including gaps between the wall and the floor, can be considered a single room when determining compliance to  $A_{min}$ , provided all of the following conditions are met as Fig. 2-11.

1) Low level opening

- ① The opening shall not be less than  $Anv_{min}$  in Table 2-2.
- ② The area of any openings above 11-13/16 inches from the floor shall not be considered in determining compliance with  $Anv_{min}$ .
- ③ At least 50 % of the opening area of  $Anv_{min}$  shall be below 7-7/8 inches from the floor.
- ④ The bottom of the opening is not more than 3-15/16 inches from the floor.

⑤ The opening is a permanent opening that cannot be closed.

⑥ For openings extending to the floor the height shall not be less than 25/32 inches above the surface of the floor covering.

2) High level opening

- ① The opening shall not be less than 50 % of  $Anv_{min}$  in Table 2-2.
- ② The opening is a permanent opening that cannot be closed.
- ③ The opening shall be at least 59 inches above the floor.
- ④ The height of the opening is not less than 25/32 inches.

3) Room size requirement

- ① The room into which refrigerant can leak, plus the connected adjacent room(s) shall have a total area not less than  $A_{min}$ .  $A_{min}$  is shown in Table 2-4.
- ② The room area in which the unit is installed shall be not less than 20 %  $A_{min}$ .  $A_{min}$  is shown in Table 2-4.

**NOTICE**

The requirement for the second opening can be met by drop ceilings, ventilation ducts, or similar arrangements that provide an airflow path between the connected rooms.

The minimum opening for natural ventilation ( $Anv_{min}$ ) in connected rooms is related to the room area ( $A$ ), the actual refrigerant charge of refrigerant in the system ( $m_c$ ), and the allowable MAXIMUM REFRIGERANT CHARGE in the system ( $m_{max}$ ).  $Anv_{min}$  can be determined according to Table 2-2.

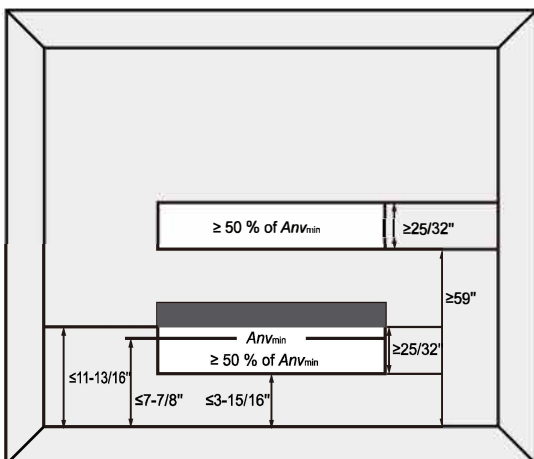

Fig. 2-11 Opening conditions for connected rooms

The minimum opening area for connected rooms

A		$m_c$		$m_{max}$		$Anv_{min}$	
ft <sup>2</sup>	m <sup>2</sup>	lb-oz	kg	lb-oz	kg	ft <sup>2</sup>	m <sup>2</sup>
100	10	17-3	7.8	6-10	3.0	1.3	0.13
110	11	17-3	7.8	7-5	3.3	1.2	0.12
120	12	17-3	7.8	8-0	3.6	1.1	0.11
130	13	17-3	7.8	8-10	3.9	1.0	0.10
140	14	17-3	7.8	9-5	4.2	1.0	0.10
150	14	17-3	7.8	10-0	4.5	0.9	0.09
160	15	17-3	7.8	10-10	4.8	0.8	0.08
170	16	17-3	7.8	11-5	5.1	0.7	0.07
180	17	17-3	7.8	12-0	5.4	0.6	0.06
190	18	17-3	7.8	12-10	5.7	0.5	0.05
200	19	17-3	7.8	13-5	6.0	0.5	0.05
210	20	17-3	7.8	14-0	6.3	0.4	0.04
220	21	17-3	7.8	14-10	6.6	0.3	0.03
230	22	17-3	7.8	15-5	6.9	0.2	0.02
240	23	17-3	7.8	16-0	7.2	0.1	0.01
250	24	17-3	7.8	16-10	7.5	0.1	0.01
260	25	17-3	7.8	17-5	7.8	0.0	0.00

Table 2-2

Note: Take the  $m_c=17$  lb 3 oz as an example.

For appliances serving two or more rooms with an air duct system, The room area calculation shall be determined based on the total area of the conditioned space ( $TA$ ) connected by ducts taking into consideration that the circulating airflow distributed to all the rooms by the appliance integral indoor fan will mix and dilute the leaking refrigerant before entering any room.

**2.4.2. The allowed maximum refrigerant charge and required minimum room area**

If the fan incorporated to an appliance is continuously operated or operation is initiated by a refrigerant detection system with a sufficient circulation airflow rate, the allowable maximum refrigerant charge ( $m_{max}$ ) and the required minimum room area ( $A_{min}/TA_{min}$ ) is shown in Table 2-3 and Table 2-4.

The allowable maximum refrigerant charge

A/TA		$m_{max}$		A/TA		$m_{max}$	
ft <sup>2</sup>	m <sup>2</sup>	lb-oz	kg	ft <sup>2</sup>	m <sup>2</sup>	lb-oz	kg
60	6	4-0	1.8	170	16	11-5	5.1
70	7	4-10	2.1	180	17	12-0	5.4
80	8	5-5	2.4	190	18	12-10	5.7
90	9	6-0	2.7	200	19	13-5	6.0
100	10	6-10	3.0	210	20	14-0	6.3
110	11	7-5	3.3	220	21	14-10	6.6
120	12	8-0	3.6	230	22	15-5	6.9
130	13	8-10	3.9	240	23	16-0	7.2
140	14	9-5	4.2	250	24	16-10	7.5
150	14	10-0	4.5	260	25	17-5	7.8
160	15	10-10	4.8				

Table 2-3

The required minimum room area

$m_c$		$A_{min}/TA_{min}$		$m_c$		$A_{min}/TA_{min}$	
lb-oz	kg	ft <sup>2</sup>	m <sup>2</sup>	lb-oz	kg	ft <sup>2</sup>	m <sup>2</sup>
3-15	1.8	59.5	5.6	11-0	5.0	165.3	15.4
4-6	2.0	66.1	6.2	11-7	5.2	171.9	16.0
4-13	2.2	72.7	6.8	11-14	5.4	178.5	16.6
5-4	2.4	79.3	7.4	12-5	5.6	185.1	17.2
5-11	2.6	86.0	8.0	12-12	5.8	191.7	17.9
6-2	2.8	92.6	8.7	13-3	6.0	198.4	18.5
6-9	3.0	99.2	9.3	13-10	6.2	205.0	19.1
7-0	3.2	105.8	9.9	14-1	6.4	211.6	19.7
7-7	3.4	112.4	10.5	14-8	6.6	218.2	20.3
7-15	3.6	119.0	11.1	14-15	6.8	224.8	20.9
8-6	3.8	125.6	11.7	15-6	7.0	231.4	21.5
8-13	4.0	132.2	12.3	15-14	7.2	238.0	22.2
9-4	4.2	138.8	12.9	16-5	7.4	244.6	22.8
9-11	4.4	145.5	13.6	16-12	7.6	251.2	23.4
10-2	4.6	152.1	14.2	17-3	7.8	257.9	24.0
10-9	4.8	158.7	14.8				

Table 2-4

The minimum circulation airflow

$m_c$		$Q_{min}$		$m_c$		$Q_{min}$	
lb-oz	kg	CFM	m <sup>3</sup> /h	lb-oz	kg	CFM	m <sup>3</sup> /h
3-15	1.8	107	182	11-0	5.0	298	506
4-6	2.0	119	202	11-7	5.2	310	527
4-13	2.2	131	223	11-14	5.4	322	547
5-4	2.4	143	243	12-5	5.6	334	567
5-11	2.6	155	263	12-12	5.8	346	588
6-2	2.8	167	284	13-3	6.0	358	608
6-9	3.0	179	304	13-10	6.2	370	629
7-0	3.2	191	325	14-1	6.4	382	649
7-7	3.4	203	345	14-8	6.6	394	669
7-15	3.6	215	365	14-15	6.8	406	690
8-6	3.8	227	386	15-6	7.0	418	710
8-13	4.0	239	406	15-14	7.2	430	731
9-4	4.2	251	426	16-5	7.4	442	751
9-11	4.4	263	447	16-12	7.6	454	771
10-2	4.6	275	467	17-3	7.8	466	792
10-9	4.8	287	488				

Table 2-5

**CAUTION**

The allowable maximum refrigerant charge of the Table 2-3 or the required minimum room area of the Table 2-4 is available only if the following conditions are met:

Minimum velocity of 3.28 ft/s, which is calculated as the indoor unit airflow divided by the nominal face area of the outlet. And the grill area shall not be deducted.

Minimum airflow rate must meet the corresponding values in Table 2-5, which is related to the actual refrigerant charge of the system ( $m_c$ ).

**NOTICE**

The maximum refrigerant limit described above applies to unventilated areas. If adding additional measures, such as areas with mechanical ventilation or natural ventilation, The maximum refrigerant charge can be increased or the minimum room area can be reduced.

**CAUTION**

If the actual room area, air outlet height, and refrigerant charge amount are not reflected in the above table, more severe cases need to be considered according to the data in the Tables 2-2, 2-3, 2-4, 2-5.

Installation scheme flow chart

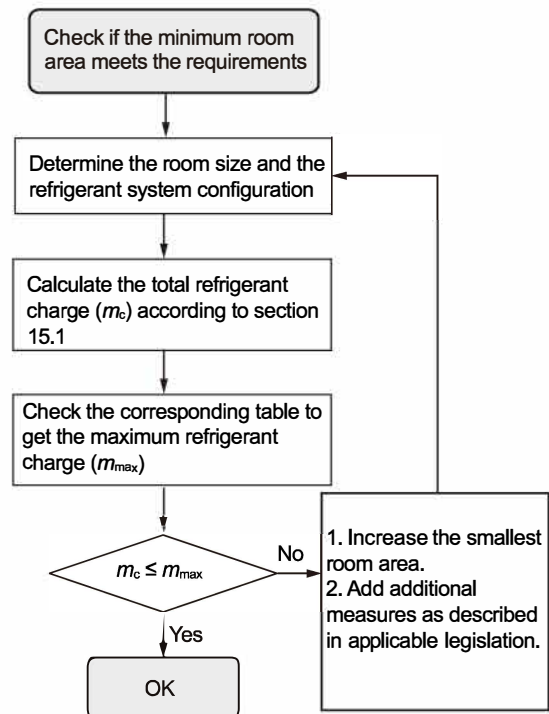

Fig. 2-12

## 2.6 Refrigerant Sensor

R454B refrigerant leakage sensor is configured for the 3.5 to 5 ton unit.

### **⚠ CAUTION**

The refrigerant leakage sensor can only use the factory model or the specified model indicated in the corresponding manual.

The R454B refrigerant leakage sensor must be used to activate the refrigerant shut-off device, the alarm device, incorporated circulation airflow or other emergency controls, which shall give an electrical signal at a predetermined alarm set point in response to leaked refrigerant.

The installation of the refrigerant leakage sensor shall allow access for checking, repair or replacement by an authorized person.

The refrigerant leakage sensor shall be installed so its function can be verified easily.

The refrigerant leakage sensor shall be protected to prevent tampering or unauthorized resetting of the pre-set value.

To be effective, the refrigerant leakage sensor must be electrically powered at all times after installation, other than when servicing.

If the refrigerant leakage sensor detects a refrigerant leak, the fan will be turned on to the maximum, and the compressor and electric heater will stop running. You should immediately leave the leak area and notify a professional for handling. System will return if refrigerant is no longer detected in 5 minutes.

The service life of the refrigerant sensor is 15 years, and it should be replaced after the service life.

To ensure the detection accuracy of the refrigerant sensor, it is recommended to blow dust off the surface of the refrigerant sensor after it is used for a long time.

### **⚠ WARNING**

LEAK DETECTION SYSTEM installed on the unit. Unit must be powered except for service.

### **NOTICE**

R454B refrigerant leakage sensor is configured for the unit, the operation of fan can initiated by R454B refrigerant sensor. Meets the incorporated circulation airflow requirements.

The allowed maximum refrigerant charge ( $m_{max}$ ) and the required minimum room area ( $A_{min}$ ) can be determined according to Table 2-3 and Table 2-4.

### 3 AIRFLOW PERFORMANCE

Airflow performance data is based on cooling performance with a coil and no filter in place. Use this performance table for appropriate unit size, external static applied to unit and allow operation within the minimum and maximum limits shown in table below for both cooling and electric heat operation.

#### 3.1 Airflow Performance Data

Table 3-1 Duct Application(208V)

Model Number	Motor Speed		SCFM								
			External Static Pressure in H <sub>2</sub> O[kPa]								
			0[0]	0.1[.02]	0.2[.05]	0.3[.07]	0.4[.10]	0.5[.12]	0.6[.15]	0.7[.17]	0.8[.20]
24	Low-Tap(1)	SCFM	787	744	691	643	/	/	/	/	/
		Watts	187	185	182	152	/	/	/	/	/
		Amps	0.98	0.77	0.75	0.73	/	/	/	/	/
	Mid-Tap(2) (Factory)	SCFM	/	/	/	882	828	751	698	/	/
		Watts	/	/	/	269	262	253	246	/	/
		Amps	/	/	/	1.37	1.34	1.31	1.27	/	/
	High-Tap(3)	SCFM	/	/	/	/	/	964	896	759	621
		Watts	/	/	/	/	/	360	330	307	276
		Amps	/	/	/	/	/	1.78	1.71	1.64	1.57
30	Low-Tap(1)	SCFM	911	869	828	782	723	/	/	/	/
		Amps	0.9	1.0	1.0	1.1	1.2	/	/	/	/
		Watts	103	113	122	131	141	/	/	/	/
	Mid-Tap(2)	SCFM	/	1031	995	961	927	876	829	782	740
		Amps	/	1.3	1.4	1.5	1.6	1.7	1.7	1.8	1.9
		Watts	/	159	170	180	190	203	213	222	230
	High-Tap(3) (Factory)	SCFM	/	/	/	/	1079	1050	1015	967	926
		Amps	/	/	/	/	2.0	2.1	2.2	2.3	2.4
		Watts	/	/	/	/	246	257	270	286	297
36	Low-Tap(2)	SCFM	1073	1031	995	961	927	876	/	/	/
		Amps	1.2	1.3	1.4	1.5	1.6	1.7	/	/	/
		Watts	148	159	170	180	190	203	/	/	/
	Mid-Tap(3)	SCFM	/	1177	1142	1110	1079	1050	1015	967	926
		Amps	/	1.7	1.8	1.9	2.0	2.1	2.2	2.3	2.4
		Watts	/	209	221	233	246	257	270	286	297
	High-Tap(4) (Factory)	SCFM	/	/	/	/	/	1232	1205	1178	1152
		Amps	/	/	/	/	/	2.8	2.9	3.0	3.1
		Watts	/	/	/	/	/	347	361	374	386
42	Low-Tap(1) (Factory)	SCFM	1545	1507	1463	1418	1366	1307	1239	1144	/
		Watts	487	479	469	458	447	433	418	400	/
		Amps	2.58	2.55	2.52	2.49	2.46	2.42	2.38	2.33	/
	Mid-Tap(2)	SCFM	/	/	/	/	1551	1488	1414	1318	1200
		Watts	/	/	/	/	728	712	693	672	644
		Amps	/	/	/	/	4.1	4.05	3.99	3.92	3.84
	High-Tap(3)	SCFM	/	/	/	/	/	/	1570	1499	1380
		Watts	/	/	/	/	/	/	812	787	759
		Amps	/	/	/	/	/	/	4.57	4.49	4.4
48	Low-Tap(1)	SCFM	1545	1507	1463	1418	1366	1307	1239	/	/
		Watts	487	479	469	458	447	433	418	/	/
		Amps	2.58	2.55	2.52	2.49	2.46	2.42	2.38	/	/
	Mid-Tap(2) (Factory)	SCFM	1740	1699	1654	1606	1551	1488	1414	1318	1200
		Watts	783	768	756	742	728	712	693	672	644
		Amps	4.27	4.22	4.18	4.14	4.1	4.05	3.99	3.92	3.84
	High-Tap(3)	SCFM	/	/	/	1800	1740	1671	1595	1499	1380
		Watts	/	/	/	874	854	833	812	787	759
		Amps	/	/	/	4.76	4.7	4.63	4.57	4.49	4.4
60	Low-Tap(3) (Factory)	SCFM	1830	1784	1742	1700	1658	1618	1579	1542	1503
		Amps	2.4	2.5	2.7	2.8	2.9	3.0	3.1	3.2	3.3
		Watts	306	320	336	350	365	380	392	407	420
	Mid-Tap(4) (Factory)	SCFM	1983	1943	1906	1862	1824	1784	1745	1709	1674
		Amps	3.1	3.2	3.3	3.4	3.5	3.6	3.7	3.9	4.0
		Watts	391	406	421	438	453	469	486	501	515
	High-Tap(5)	SCFM	2250	2201	2159	2120	2083	2047	2023	1978	1946
		Amps	4.3	4.4	4.5	4.6	4.7	4.9	5.0	5.1	5.2
		Watts	562	575	593	609	627	645	666	682	700

Table 3-2 Duct Application(230V)

Model Number	Motor Speed		SCFM								
			External Static Pressure in H <sub>2</sub> O[kPa]								
			0[0]	0.1[.02]	0.2[.05]	0.3[.07]	0.4[.10]	0.5[.12]	0.6[.15]	0.7[.17]	0.8[.20]
24	Low-Tap(1)	SCFM	885	841	795	743	/	/	/	/	/
		Watts	227	224	221	216	/	/	/	/	/
		Amps	2.07	2.07	2.06	2.05	/	/	/	/	/
	Mid-Tap(2) (Factory)	SCFM	/	/	/	988	957	882	767	/	/
		Watts	/	/	/	339	323	307	291	/	/
		Amps	/	/	/	2.31	2.28	2.26	2.24	/	/
	High-Tap(3)	SCFM	/	/	/	/	/	996	967	928	896
		Watts	/	/	/	/	/	412	392	379	361
		Amps	/	/	/	/	/	2.65	2.57	2.52	2.46
30	Low-Tap(1)	SCFM	911	869	828	782	723	/	/	/	/
		Amps	0.9	1.0	1.0	1.1	1.2	/	/	/	/
		Watts	103	113	122	131	141	/	/	/	/
	Mid-Tap(2)	SCFM	/	1031	995	961	927	876	829	782	740
		Amps	/	1.3	1.4	1.5	1.6	1.7	1.7	1.8	1.9
		Watts	/	159	170	180	190	203	213	222	230
	High-Tap(3) (Factory)	SCFM	/	/	/	/	1079	1050	1015	967	926
		Amps	/	/	/	/	2.0	2.1	2.2	2.3	2.4
		Watts	/	/	/	/	246	257	270	286	297
36	Low-Tap(2)	SCFM	1073	1031	995	961	927	876	/	/	/
		Amps	1.2	1.3	1.4	1.5	1.6	1.7	/	/	/
		Watts	148	159	170	180	190	203	/	/	/
	Mid-Tap(3)	SCFM	/	1177	1142	1110	1079	1050	1015	967	926
		Amps	/	1.7	1.8	1.9	2.0	2.1	2.2	2.3	2.4
		Watts	/	209	221	233	246	257	270	286	297
	High-Tap(4) (Factory)	SCFM	/	/	/	/	/	1232	1205	1178	1152
		Amps	/	/	/	/	/	2.8	2.9	3.0	3.1
		Watts	/	/	/	/	/	347	361	374	386
42	Low-Tap(1) (Factory)	SCFM	/	/	/	/	1554	1495	1429	1340	1230
		Watts	/	/	/	/	527	510	469	465	432
		Amps	/	/	/	/	2.29	2.22	2.15	2.02	1.88
	Mid-Tap(2)	SCFM	/	/	/	/	/	/	/	1503	1384
		Watts	/	/	/	/	/	/	/	566	533
		Amps	/	/	/	/	/	/	/	2.46	2.32
	High-Tap(3)	SCFM	/	/	/	/	/	/	/	/	1548
		Watts	/	/	/	/	/	/	/	/	662
		Amps	/	/	/	/	/	/	/	/	2.88
48	Low-Tap(1)	SCFM	1735	1701	1654	1608	1554	1495	1429	1340	/
		Watts	579	573	561	545	527	510	469	465	/
		Amps	2.52	2.49	2.44	2.37	2.29	2.22	2.15	2.02	/
	Mid-Tap(2) (Factory)	SCFM	/	/	/	1790	1730	1665	1591	1503	1384
		Watts	/	/	/	658	642	614	592	566	533
		Amps	/	/	/	2.86	2.79	2.67	2.57	2.46	2.32
	High-Tap(3)	SCFM	/	/	/	/	/	/	1761	1666	1548
		Watts	/	/	/	/	/	/	732	704	662
		Amps	/	/	/	/	/	/	3.18	3.06	2.88
60	Low-Tap(3) (Factory)	SCFM	1830	1784	1742	1700	1658	1618	1579	1542	1503
		Amps	2.4	2.5	2.7	2.8	2.9	3.0	3.1	3.2	3.3
		Watts	306	320	336	350	365	380	392	407	420
	Mid-Tap(4) (Factory)	SCFM	1983	1943	1906	1862	1824	1784	1745	1709	1674
		Amps	3.1	3.2	3.3	3.4	3.5	3.6	3.7	3.9	4.0
		Watts	391	406	421	438	453	469	486	501	515
	High-Tap(5)	SCFM	2250	2201	2159	2120	2083	2047	2023	1978	1946
		Amps	4.3	4.4	4.5	4.6	4.7	4.9	5.0	5.1	5.2
		Watts	562	575	593	609	627	645	666	682	700

\* The above airflow data for reference only.

- The air distribution system has the greatest effect on airflow. The duct system is totally controlled by the contractor. For this reason, the contractor should use only industry-recognized procedures.
- The installers should balance the air distribution system to ensure proper quiet airflow to all rooms in the home. This ensures a comfortable living space.
- Heat pump systems require a specified airflow. Each ton of cooling requires between 300 and 450 cubic feet of air per minute (CFM), or 400 CFM nominally.
- Duct design and construction should be carefully done. System performance can be lowered dramatically due to poor duct design.

- Air supply diffusers must be selected and located carefully, they must be sized and positioned to deliver treated air along the perimeter of the space. If they are too small for their intended airflow, they will be noisy. If they are not located properly, they will cause drafts. Return air grilles must be properly sized to carry air back to the blower or they will also cause noise.
- An air velocity meter or airflow hood can give a reading of system CFM.

The installation will cause some pressure drop and the brief data can be found in Table 3-3

Table 3-3 Electric Heater Pressure Drop Tables(in H<sub>2</sub>O)

**Small Cabinet: 24 K, 30 K, 36 K**

Pressure Drop Heater	STANDARD CFM (SCFM)					
	900	1000	1100	1200	1300	1400
5 kW	0.05	0.05	0.05	0.05	0.05	0.1
7.5 kW	0.05	0.05	0.05	0.05	0.05	0.1
10 kW	0.05	0.05	0.05	0.05	0.05	0.1
15 kW	/	/	0.1	0.1	0.1	0.1

**Large Cabinet: 42 K, 48 K, 60 K**

Pressure Drop Heater	STANDARD CFM (SCFM)							
	1500	1600	1700	1800	1900	2000	2100	2200
5 kW	0.1	0.1	0.1	0.1	0.15	0.15	0.15	0.15
7.5 kW	0.1	0.1	0.1	0.1	0.15	0.15	0.15	0.15
10 kW	0.1	0.1	0.15	0.15	0.15	0.15	0.15	0.15
15 kW	/	/	0.2	0.2	0.2	0.2	0.2	0.2
20 kW	/	/	0.2	0.2	0.2	0.2	0.2	0.25

## 4 DUCTWORK

Ductwork should be sized and installed by the installing contractor in accordance with the Manual D from the Air Conditioning Contractors of America, and all national, state and local codes.

### **⚠ WARNING**

If appliances connected via an air duct system to one or more rooms are installed in a room with an area less than shown in section "Refrigerant Charge and Room Area Limitations" Table 2-4, that room shall be without continuously operating open flames (e.g. an operating gas appliance) or other potential ignition sources (for e.g. an operating electric heater, hot surfaces). A flame-producing device may be installed in the same space if the device is provided with an effective flame arrest.

For appliances connected via an air duct system to one or more rooms, auxiliary devices which may be a potential ignition source shall not be installed in the duct work. Examples of such potential ignition sources are hot surfaces with a temperature exceeding 700 °C and electric switching devices.

For appliances connected via an air duct system to one or more rooms, only auxiliary devices approved by the appliance manufacturer or declared suitable with the refrigerant shall be installed in connecting ductwork.

### **NOTICE**

On ductwork exposed to outside air space, use at least 2" of insulation and a vapor barrier. Flexible joint may be used to reduce noise.

A closed return duct system shall be should't preclude use of economizers or ventilation air intake.

### **⚠ CAUTION**

When fasten duct work to the side flanges on the unit, please insert the screws through the duct flanges only and DO NOT insert the screws through the casing.

### **⚠ CAUTION**

Outdoor duct work must be insulated and waterproofed.

### **NOTICE**

Please refer to Fig. 2-4 and 2-6 for information about supply and return air duct openings.

## 5 CONDENSATE DRAIN CONNECTION

Please consult local codes for special requirements and manufacturer will not be responsible for any damages due to the failure to follow these requirements.

To provide extra protection from water damage, please install an additional drain pan and drain line provided by installer.

### 5.1 Install Drain Pipe

1. Use the provided female NPT threaded fitting for outside connection and make sure that drain holes are not blocked.
2. Insulation may be needed for drain line to prevent sweating.
3. Drain pan has two drain connections on each side to provide flexibility of connection and drainage. Make sure proper pitch and plugging if second connection is not used.
4. Use a sealing compound on male pipe threads and install the condensate drain line (NPT) to spill into an open drain.
5. Ensure a trap is included in the condensate drain line.

## 6 ABOUT THE AIR FILTER

### 6.1 Air Filter (Not Factory-Installed)

Regular cleaning is required for air filters according to the manufacturer's specifications.

External filter or other means of filtration is required. Units should be sized for a maximum of 300 feet/min air velocity or what is recommended for the type of filter installed.

Filter application and placement are critical to airflow, which may affect the heating and cooling system performance. Reduced airflow can shorten the life of the system's major components, such as motor, limits, elements, heat relays, evaporator coil or compressor. Consequently, we recommend that the return air duct system have only one filter location. For systems with a return air filter grill or multiple filter grills, can have a filter installed at each of the return air openings.

If adding high efficiency filters or electronic air filtration systems, it is very important that the air flow is not reduced. If air flow is reduced the overall performance and efficiency of the unit will be reduced. It is strongly recommended that a professional installation technician is contacted to ensure installation of these such filtration systems are installed correctly.

**IMPORTANT:** Do not double filter the return air duct system. Do not filter the supply air duct system. This will change the performance of the unit and reduce airflow.

## ⚠ WARNING

Do not operate the system without filters. A portion of the dust entrained in the air may temporarily lodge in the duct and run at the supply registers. Any circulated dust particles could be heated and charred by contact with the air handler elements. This residue could soil ceilings, walls, drapes, carpets and other articles in the house.

Soot damage may occur with filters in place, when certain types of candles, oil lamps or standing pilots are burned.

## NOTICE

The air filter must conform with the UL 900 Standard.

### AIR FILTER REMOVAL

1. Remove bolts manually, remove air filter recover.
2. Hold the edge of the air filter and extract out.
3. Clean the air filter.
4. Install new filter so that the arrow on the filter is in the same direction as airflow.

## 7 ELECTRICAL WIRING

Field wiring must comply with the National Electric Code (NEC) or Canadian Electrical Code (CEC) and any applicable local ordinance.

## ⚠ WARNING

Disconnect all power to unit before installing or servicing. More than one disconnect switch may be required to de-energize the equipment.

Hazardous voltage can cause severe personal injury or death.

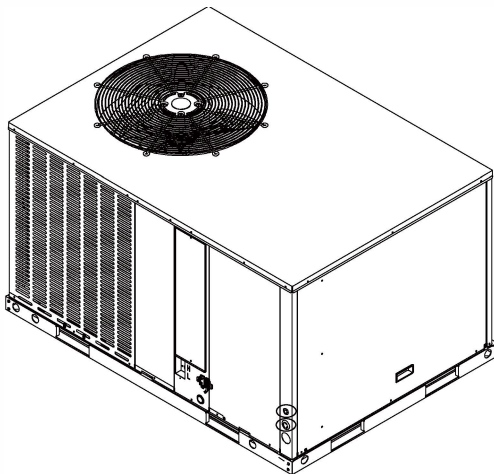

When installing power cables (in the middle) and signal cables (in the top) of the whole device, please remove the cable running apron firstly, install the bushing secondly, and finally install the power cables.

## 7.1 Power Wiring

1. Proper electrical power should be available at unit. Voltage tolerance should not be over 10% from rating voltage.

2. If any of the wire need to be replaced, replacement wire must be the same type as shown in nameplate, wiring diagram and electrical data sheet.

3. Install a branch circuit disconnect of adequate size to handle starting current. The disconnect should be located within sight and readily accessible to the unit.

4. **ELECTRIC HEATER** - If the Electric Heater is installed, unit may be equipped with 30 A to 60 A. circuit breakers or fuse. These breaker(s) protect the internal wiring in the event of a short circuit and serve as a disconnect.

- Supply circuit power wiring must be 221 °F minimum copper conductors only.

See Electrical Data on the unit for ampacity, wire size and circuit protector requirements. Supply circuit protective devices can be either fuses or "HACR" type circuit breakers.

- 1-3/8" knockouts inside the cabinet are provided for connection of power wiring to electric heater.

- Power wiring is connected to the power terminal block in unit electric cabinet.

See Electrical Heater Installation Instruction for details.

## 7.2 Grounding

## ⚠ WARNING

The unit must be permanently grounded. Failure to do so may result in electrical shock and causing personal injury or death.

- The unit must be electrically grounded in accordance with local codes or the national electric code.
- Grounding could be accomplished by attaching ground wire(s) to ground lug(s) provided in the unit wiring compartment.

## 7.3 Control Wiring

Thermostat should be mounted on an inside wall about 58" from floor and will not be affected by unconditioned air, sun and/or heat exposure. Follow the instruction carefully because there are many wiring requirements. See Fig. 7-1 and Fig. 7-2.

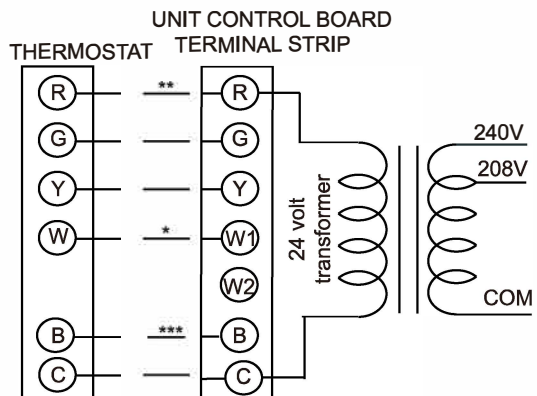

Fig. 7-1 Typical Field Control Wiring Diagram

- \*\*\* B wire be used with heat pump system only, reversing valve energizes at the heating mode, and cut off at the cooling mode.
- \*\* Minimum wire size of 18 AWG wire should be used for all field installed 24 volt wire.
- \* Only required on units with supplemental electric heat.

### ⚠ CAUTION

Class 2 low voltage control wiring should not be run in conduit with main power wiring and must be separated from power wiring, unless class 1 wire of proper voltage rating is used.

- Low voltage control wiring should be 18 A WG color-coded. For lengths longer than 50 ft, 16 A WG wire should be used.
- Two 7/8" holes can be used for control wires going into the unit, one on left side and one at the bottom.
- Make sure, after installation, separation of control wiring and power wiring has been maintained.

### ⚠ CAUTION

Label all wire prior to disconnection when servicing controls. Wiring errors can cause improper and dangerous operation. Verify proper operation after servicing.

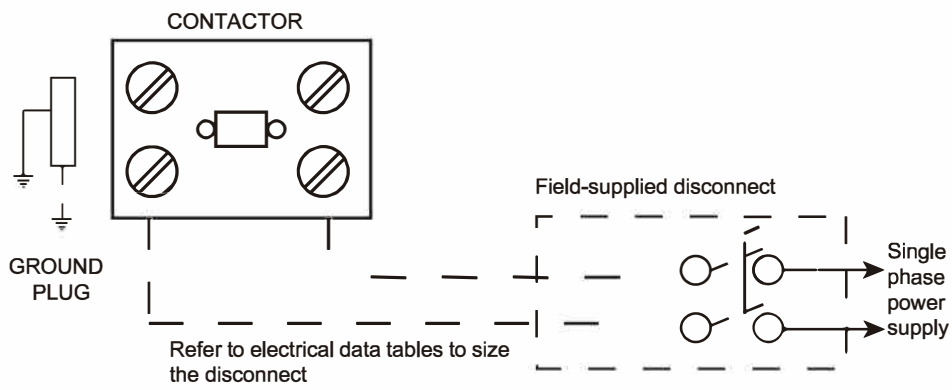

**Fig. 7-2 Typical Field Power Wiring Diagram**

## 8 Electric Heater Kit (Optional)

### 8.1 Electric Heater Kit Electrical Data

Size (Tons)	Volt	Heater Circuit (without units)					
		Model	kW	Stages	Amps	MCA (Amps)	Max Fuse Breaker Size(Amps)
24(2.0)	208/230-1-60	None	-	-	None		
		CHE7-05C	3.8/5	1	18.1/20.8	23/26	25/30
		CHE7-08C	5.6/7.5	1	27.1/31.3	34/40	35/40
		CHE7-10C	7.5/10	1	36.1/41.7	46/53	50/60
30(2.5)	208/230-1-60	None	-	-	None		
		CHE7-05C	3.8/5	1	18.1/20.8	23/26	25/30
		CHE7-08C	5.6/7.5	1	27.1/31.3	34/40	35/40
		CHE7-10C	7.5/10	1	36.1/41.7	46/53	50/60
		CHE7-15C	11.3/15	2	54.2/62.5	68/79	70/80
36(3.0)	208/230-1-60	None	-	-	None		
		CHE7-05C	3.8/5	1	18.1/20.8	23/26	25/30
		CHE7-08C	5.6/7.5	1	27.1/31.3	34/40	35/40
		CHE7-10C	7.5/10	1	36.1/41.7	46/53	50/60
		CHE7-15C	11.3/15	2	54.2/62.5	68/79	70/80
42(3.5)	208/230-1-60	None	-	-	None		
		CHE7-05C	3.8/5	1	18.1/20.8	23/26	25/30
		CHE7-08C	5.6/7.5	1	27.1/31.3	34/40	35/40
		CHE7-10C	7.5/10	1	36.1/41.7	46/53	50/60
		CHE7-15C	11.3/15	2	54.2/62.5	68/79	70/80
		CHE7-20C	15/20	2	72.3/83.4	91/105	100/110
48(4.0)	208/230-1-60	None	-	-	None		
		CHE7-05C	3.8/5	1	18.1/20.8	23/26	25/30
		CHE7-08C	5.6/7.5	1	27.1/31.3	34/40	35/40
		CHE7-10C	7.5/10	1	36.1/41.7	46/53	50/60
		CHE7-15C	11.3/15	2	54.2/62.5	68/79	70/80
		CHE7-20C	15/20	2	72.3/83.4	91/105	100/110
60(5.0)	208/230-1-60	None	-	-	None		
		CHE7-05C	3.8/5	1	18.1/20.8	23/26	25/30
		CHE7-08C	5.6/7.5	1	27.1/31.3	34/40	35/40
		CHE7-10C	7.5/10	1	36.1/41.7	46/53	50/60
		CHE7-15C	11.3/15	2	54.2/62.5	68/79	70/80
		CHE7-20C	15/20	2	72.3/83.4	91/105	100/110

1. Minimum Circuit Ampacity.
2. Maximum Over Current Protection per Standard UL 60335.
3. Fuse or HACR circuit breaker size installed at factory or field installed.

## 8.2 Electric Heater Kit Install Information

Installation of electric heat sections must conform with standard in National Fire Protection Association (NFPA) Standard for Installation of Air Conditioning and Ventilation Systems NFPA No. 90A, Standard for the Installation of Residence Type Warm Air Heating and Air Conditioning System NFPA No. 90B, manufacturer's installation instructions and local municipal building codes. Heaters are approved for clearance to combustible materials as listed on heater rating plate. Accessibility and service clearances must take precedence over fire protection clearances. All wiring must conform with local codes and the National Electric Code (NEC). ANSI-C1-1978.

### **⚠ CAUTION**

As with any mechanical equipment, contact with sharp sheet metal edges can result in personal injury. Take care while handling this equipment and wear gloves and protective clothing.  
The circuit breaker of electric heater kit in indoor unit cannot be used as air switch for power cables and cannot be operated by users. Maintenance personnel need to disconnect the main switch before servicing.  
If install a third-party electric heater kit, ensure that all components used of the electric heater kit meet the A2L class flammable refrigerant regulations.

### **⚠ WARNING**

Supply circuit power wiring must be 167 °F (75 °C) minimum copper conductors only. See Table 9-3 for Electrical Data in this section for ampacity, wire size and circuit protector requirement. Supply circuit protective devices may be either fuses or "HACR" type circuit breakers.

### **NOTICE**

Please refer to the manual of electric heater kit for detailed installation and wiring instructions.  
Heat pump systems require a specified airflow. Each ton of cooling requires between 350 and 450 cubic feet of air per minute(CFM), or 400 CFM nominally.

## 9 SYSTEM OPERATION

### 9.1 Compressor Crankcase Heater (Optional)

Refrigerant migration during the OFF cycle can result in noisy start-ups, therefore a Crankcase Heater (CCH) is used to minimize refrigerant migration thereby minimizing start-up noise and/or bearing "wash out". All CCHs must be installed on the lower half of the compressor shell. Its purpose is to warm the compressor during the OFF cycle, driving refrigerant from compressor. After extended shutdown periods in cold weather, it is recommended to allow CCH to be energized for at least 12 h prior to compressor operation by applying line voltage to heat pump with thermostat OFF.

The crankcase heating start must meet two conditions:

- A. Outdoor temperature  $< 41^{\circ}\text{F}$
- B. At power up or if the compressor has been off for more than 3 h.

The crankcase heating stop must meet the following condition:

Outdoor temperature  $\geq 45^{\circ}\text{F}$  or compressor starts.

### 9.2 Reversing Valve

Reversing valve energizes at the heating conditions, and cuts off at the cooling condition.

### 9.3 Wind Pressure Switch

Wind pressure switch detect the pressure difference between the wind wheel and the electronic control chamber, to determine whether the indoor airflow meets the requirements of electrical heater. If indoor airflow below the range required in Table 3-1 and Table 3-2, the pressure difference between two sides of the wind pressure switch may be lower than the limit value, and the wind pressure switch will cut off, making the electrical heater stop working.

If indoor airflow meets the requirements, but the electrical heater stop working, the below contents should be checked:

1. The signal cable of wind pressure switch disconnected.
2. Connection pipe of wind pressure switch bend or blocked.
3. Wind pressure switch is damaged.

#### **CAUTION**

The wind pressure switch can only use the factory model.

## 9.4 Protection Function

- T3 = Outdoor Coil Temperature  
T3  $> 143.6^{\circ}\text{F}$ , compressor stops working  
T3  $< 125.6^{\circ}\text{F}$ , compressor restarts working
- T4 = Ambient Temperature  
T4  $< 0^{\circ}\text{F}$ , compressor can't start  
T4  $> 5^{\circ}\text{F}$ , compressor restarts working  
If  $32^{\circ}\text{F} \leq T4 \leq 120^{\circ}\text{F}$ , unit can operate in cooling  
If  $0^{\circ}\text{F} \leq T4 \leq 75^{\circ}\text{F}$ , unit can operate in heating

#### **NOTICE**

When T4  $< 0^{\circ}\text{F}$ , the outdoor unit would provide a signal to drive up the heater installed in the indoor unit.

- Discharge temperature protection  
Discharge temperature  $> 239^{\circ}\text{F}$ , compressor stops working.  
Discharge temperature  $< 167^{\circ}\text{F}$ , compressor restarts working.

#### **NOTICE**

In stand-by status, the compressor will not start in Discharge temperature protection. Within 1 h, if 5 protection cycles occur, the system will be locked for 30 mins. If this situation occurs 4 times in 3 days, the system will be locked. It will be restore after power cycle.

- High pressure protection  
High pressure  $> 580$  psig, compressor and outdoor fan motor stop working.  
High pressure  $< 435$  psig, compressor and outdoor fan motor restart working (3 min delay necessary).
- Low pressure protection  
Low pressure  $< 15$  psig, compressor and outdoor fan motor stop working.  
Low pressure  $> 32$  psig, compressor and outdoor fan motor restart working (3 min delay necessary).

#### **NOTICE**

In stand-by status, the compressor will not start in low pressure protection. Within 30 min, if 4 protection cycles occur, the system will be locked. It will be restore after power cycle.

## 9.5 LED Status

Indicator light description:

The module board has an indicator light, LED 1(RED), which indicates the motor status.

1. When powered on, the LED 1 light will be on for 3 s first, then the software version number is displayed. The number of times the LED 1 light flashes represents the software version number value;
2. When in standby mode, the LED 1 light flashes slowly at 4 Hz, lights up for 2 s, and turns off for 2 s;
3. When running, the LED 1 light is always on;
4. When a fault occurs: the LED 1 light flashes. The flashing LED 1 light flashes with the fault category number as the number of times, then stops for 3 s, and keeps cycling until the fault state is cleared. The shortest fault display is 60 s or the restart is successful. The flashing cycle is 800 ms.
5. When a communication fault occurs, the LED 1 flashes quickly with a cycle of 400 ms until the communication is restored.

## 9.6 Defrost Mode

Manual defrost mode

When the button "Force" is pressed for 6s, the system turns to the defrost mode. The defrost mode exits by the logic of shut-down conditions of defrost mode.

## 9.7 Temperature Sensor Resistance Table

Temperature °F	Resistance kΩ	Temperature °F	Resistance kΩ	Temperature °F	Resistance kΩ	Temperature °F	Resistance kΩ
-4	106.73	37	29.87	78	10	119	3.69
-3	103.25	38	29.22	79	9.5	120	3.61
-2	99.89	39	28.19	80	9.26	121	3.53
-1	96.65	40	27.39	81	9.03	122	3.45
0	93.53	41	26.61	82	8.81	123	3.38
1	90.53	42	25.85	83	8.59	124	3.3
2	87.62	43	25.12	84	8.38	125	3.23
3	84.83	44	24.42	85	8.17	126	3.16
4	82.13	45	23.73	86	7.97	127	3.1
5	79.52	46	23.07	87	7.78	128	3.03
6	77.01	47	22.42	88	7.59	129	2.96
7	74.58	48	21.8	89	7.4	130	2.9
8	72.24	49	21.2	90	7.22	131	2.84
9	69.98	50	20.61	91	7.05	132	2.78
10	67.8	51	20.04	92	6.88	133	2.72
11	65.69	52	19.49	93	6.72	134	2.67
12	63.65	53	18.96	94	6.56	135	2.61
13	61.68	54	18.44	95	6.4	136	2.56
14	59.78	55	17.94	96	6.25	137	2.5
15	57.95	56	17.45	97	6.1	138	2.45
16	56.17	57	16.98	98	5.96	139	2.4
17	54.46	58	16.52	99	5.82	140	2.35
18	52.8	59	16.08	100	5.68	141	2.3
19	51.2	60	15.65	101	5.55	142	2.25
20	49.65	61	15.23	102	5.42	143	2.21
21	48.16	62	14.83	103	5.3	144	2.16
22	46.71	63	14.43	104	5.18	145	2.12
23	45.31	64	14.05	105	5.06	146	2.08
24	43.95	65	13.68	106	4.94	147	2.03
25	42.64	66	13.32	107	4.83	148	1.99
26	41.38	67	12.97	108	4.72	149	1.95
27	40.15	68	12.64	109	4.61	150	1.91
28	38.97	69	12.31	110	4.51	151	1.88
29	37.82	70	11.99	111	4.41	152	1.84
30	36.71	71	11.68	112	4.31	153	1.8
31	35.64	72	11.38	113	4.21	154	1.77
32	34.6	73	11.09	114	4.12	155	1.73
33	33.59	74	10.8	115	4.03	156	1.7
34	32.61	75	10.53	116	3.94	157	1.66
35	31.67	76	10	117	3.85	158	1.63
36	30.76	77	10	118	3.77	159	1.6

Table 9-1

## 9.8 Thermostat Signals

Table 9-2: Thermostat Signals

Signal	State	Board Function
G	ON	Blower instant ON
	OFF	24/30/36/60K:Blower 90 s. delay OFF 42/48K:Blower delay OFF according to wiring diagram
G & W1	ON	Blower instant ON Heater bank 1 elec.onstant ON
	OFF	Heater bank 1 elec.instant OFF 24/30/36/60K:Blower 90 s. delay OFF 42/48K:Blower delay OFF according to wiring diagram
G & W & W2	ON	Blower instant ON Heater 1 instant ON Heater 2 instant ON
	OFF	24/30/36/60K:Blower 90 s. delay OFF 42/48K:Blower delay OFF according to wiring diagram Heater 1 instant OFF Heater 2 instant OFF
G & Y	ON	Blower instant ON Compressor and outdoor fan instant ON
	OFF	Compressor and outdoor fan instant OFF 24/30/36/60K:Blower 90 s. delay OFF 42/48K:Blower delay OFF according to wiring diagram
G & B & Y	ON	4-way valve instant ON Blower instant ON Compressor and outdoor fan instant ON
	OFF	Compressor and outdoor fan instant OFF 24/30/36/60K:Blower 90 s. delay OFF 42/48K:Blower delay OFF according to wiring diagram 4-way valve instant OFF
G & B & Y & W1	ON	4-way valve instant ON Blower instant ON Compressor and outdoor fan instant ON Heater 1 instant ON
	OFF	4-way valve instant OFF 24/30/36/60K:Blower 90 s. delay OFF 42/48K:Blower delay OFF according to wiring diagram Compressor and outdoor fan instant OFF Heater 1 instant OFF
G & B & Y & W1 & W2	ON	4-way valve instant ON Blower instant ON Compressor and outdoor fan instant ON Heater 1 instant ON Heater 2 instant ON
	OFF	4-way valve instant OFF 24/30/36/60K:Blower 90 s. delay OFF 42/48K:Blower delay OFF according to wiring diagram Compressor and outdoor fan instant OFF Heater 1 instant OFF Heater 2 instant OFF

Table 9-3: Thermostat Wire Color

Thermostat Wire Color	Function
Red	Power wire
Black	Power wire
White	Heater signal 1
Green	Blower fan signal
Yellow	Compressor signal
Blue	Reversing valve signal
Brown	Heater signal 2

## 10 OPERATION CHECK-UP

### • Cooling Startup

1. Turn thermostat to OFF and turn power to ON
2. Turn ON thermostat and set as high as possible
3. Turn Fan switch ON and indoor blower should run
4. Turn fan switch to AUTO, system switch to COOL and thermostat temperature setting below room temperature.  
Unit should run in COOLING mode.

### • Heating Startup

After normal cooling run

1. Turn thermostat switch to HEAT. After unit stops, wait about 5 min.
2. Turn thermostat setting above room temperature.  
Unit should run in HEATING mode.

After unit has run for a while, check the following:

1. Are fans running properly?
2. Is compressor running correctly?
3. Check refrigerant charge.
4. Check duct connection for leaks.
5. Check for tubing and sheet metal rattles.

(See Wiring Diagram for electric connection detail.)

## 11 ERROR CODE AND TROUBLE SHOOTING

### ⚠ WARNING

Component trouble shooting requires opening control box with power on.  
Use extreme care while working on this condition. Check nameplate and this instruction when making wire connections.

### 11.1 Error Code of Module Board

Code	Description	Possible Reason
E3	T3 sensor fault	T3 sensor is short circuit or open circuit
E4	T4 sensor fault	T4 sensor is short circuit or open circuit
E8	Capacity setting not set	Capacity setting(SW2) isn't set/Program error
E9	R110 resistor or drive chip software fault	Fan is failure/Control board in outdoor unit is failure
P2	LPC protection	Poor heat exchange on evaporation side/LPC fault/ Charging leakage (low refrigerant)/piston blocked
P4	Discharge temperature protection	High temperature and overload/Throttle blockage/Charging leakage (low refrigerant)/DTS failure
P5	T3 high-temperature protection	High temperature and overload/Poor heat exchange on condensing side/T3 failure
AL	Ambient temperature limitation	Ambient temperature is out of the range/There are other heat sources around T4
H0	Communication fault between drive chip and main control chip	Program error/Control board in outdoor unit is failure
n1X-n6X	Fan drive fault	Wiring error/Fan is failure

Table 11-1

### 11.2 Error Code of Control Board(Only 42 K/48 K/60 K)

The unit LED will flash when the unit is abnormal. Security consideration, the outdoor unit shutdown until the abnormal condition is corrected.

NO.	LED1 Status	Description
1	3Flash/Cycle	R454B refrigerant sensor fault
2	4Flash/Cycle	R454B refrigerant sensor communication fault
3	Keep Flashing	R454B refrigerant leakage protection in indoor unit
4	8Flash/Cycle	R454B refrigerant sensor over service life
NO.	LED1 Status	Possible Reason
1	3Flash/Cycle	R454B refrigerant sensor failure
2	4Flash/Cycle	Wiring error/ R454B refrigerant sensor failure
3	Keep Flashing	R454B refrigerant leakage/ R454B refrigerant sensor failure
4	8Flash/Cycle	R454B refrigerant sensor over service life/R454B refrigerant sensor failure

Table 11-2

### NOTICE

The flash interval is 2 s. For example, 3 Flash /  
Cycle is flash three times every 2 s.

### ⚠ CAUTION

If the refrigerant sensor over service life, should be  
replaced by an authorized person.

If a leak is detected, follow safety procedures:  
Immediately evacuate all persons from the room or  
space, and contact the qualified licensed service  
personnel to advise them that the refrigerant  
R454B (A2L class flammable refrigerant) leak has  
occurred.



## 11.4 Status Code

Code	Description
--	Standby
-C	Cooling mode
-H	Heating mode
FC	Forced cooling mode
dF	Defrosting mode
CH	Abnormal signal

Table 11-4

## 11.5 Parameter Point Check Table

To display system parameters, press the "Check" button to index through the series of parameters available.

The first time you press the "Check" button, it will display the sequence, and after 1 s it will display the value of the parameter. If you press the "Check" button again, it will display the next sequence.

After 30 s on same parameter, the display will revert back to normal status.

NO.	Point check content
1	Unit capacity
2	Operation mode
3	Current fan speed(Actual speed divided by 10, 560R is represented by '56.', 1050R is represented by 'A5.')
4	Target fan speed(Actual speed divided by 10, for example, 560R is represented by '56.', 1050R is represented by 'A5.')
5	T3 temperature(°F)(if the value is less than 100, the actual value is displayed. if over 100, divided by 10, 135 is represented by '13.', if it is negative, '1.0' means -10, '.5' means -5)
6	T4 temperature(°F)(if the value is less than 100, the actual value is displayed. if over 100, divided by 10, 135 is represented by '13.', if it is negative, '1.0' means -10, '.5' means -5)
7	Compressor running time(day) (if the value is less than 100, the actual number of days is displayed. if over 100 and less than 1000, 360 days are represented by '36.', if over 1000, 3600 days are represented by '3.6.')
8	Main control chip software version
9	Drive chip software version
10	Y1 signal state(1=ON, 0=OFF)
11	B signal state(1=ON, 0=OFF)
12	W signal state(1=ON, 0=OFF)
13	Y2 signal state(1=ON, 0=OFF)
14	RV condition (1=ON, 0=OFF)
15	High wind pattern (1=ON, 0=OFF)
16	Last fault code
17	Last second fault code
18	Last third fault code
19	--

Table 11-5

# HP System Wiring Diagram (24/30/36K)

**WARNING: HAZARDOUS VOLTAGE. DISCONNECT ALL ELECTRIC POWER INCLUDING REMOTE DISCONNECTS BEFORE SERVICING. INSURE THAT ALL CAPACITORS HAVE DISCHARGED STORED VOLTAGE.**

**NOTICE:**  
 1. B terminal is connected and energized for heating operation.  
 2. W terminal is energized in defrosting operation.

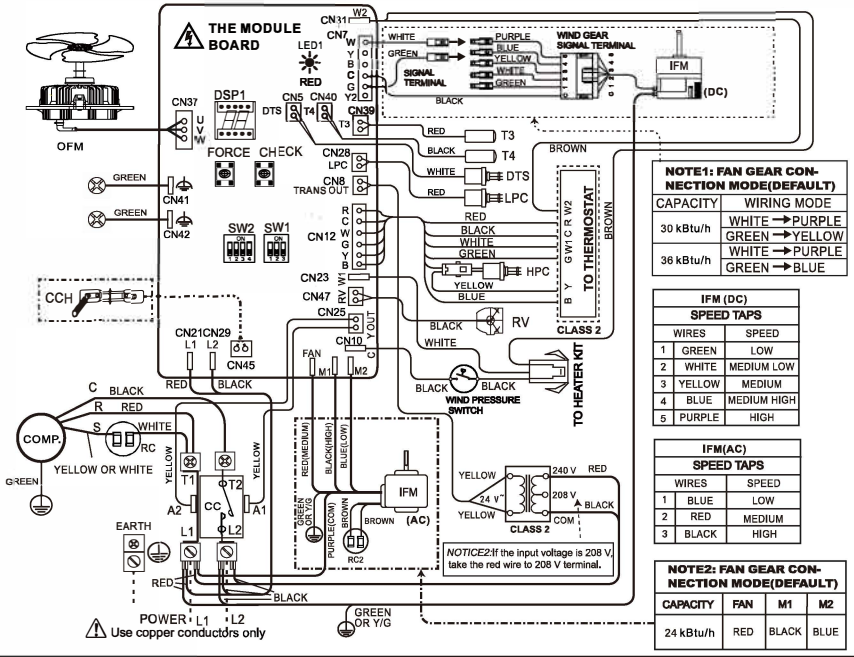

**NOTE1: FAN GEAR CONNECTION MODE(DEFAULT)**

CAPACITY	WIRING MODE
30 kBTu/h	WHITE → PURPLE GREEN → YELLOW
36 kBTu/h	WHITE → PURPLE GREEN → BLUE

**IFM (DC) SPEED TAPS**

WIRES	SPEED
1 GREEN	LOW
2 WHITE	MEDIUM LOW
3 YELLOW	MEDIUM
4 BLUE	MEDIUM HIGH
5 PURPLE	HIGH

**IFM (AC) SPEED TAPS**

WIRES	SPEED
1 BLUE	LOW
2 RED	MEDIUM
3 BLACK	HIGH

**NOTE2: FAN GEAR CONNECTION MODE(DEFAULT)**

CAPACITY	FAN	M1	M2
24 kBTu/h	RED	BLACK	BLUE

**SW1**

SW1-1	SW1-2	SW1-3
ON	ON	ON
OFF	OFF	OFF

**CAPACITY SETTING**

MODEL	24 kBTu/h	30 kBTu/h	36 kBTu/h
13.4 HP	001,1	010,1	010,1
	42 kBTu/h	48 kBTu/h	60 kBTu/h
	3.5 TON	4 TON	5 TON
	100,1	100,1	100,1

**SW2 - 4 definition**

SW2-1	SW2-2	SW2-3	SW2-4
ON	ON	ON	ON
OFF	OFF	OFF	OFF

**Hazardous voltage line**  
 - Factory standard \_\_\_\_\_  
 - Field installed - - - - -  
 - Factory optional - . . . . .

**Extra-low-voltage line**  
 - Factory standard \_\_\_\_\_  
 - Factory optional - . . . . .

**0/1 DEFINITION OF DIP SWITCH**

CODE	DESCRIPTION
--	Standby
-C	Cooling mode
-H	Heating mode
FC	Forced cooling mode
dF	Defrosting mode
CH	Abnormal signal

**Force**

Press 1 s	Forced cooling mode
Press 6 s	Forced defrosting mode

**Check**

Press 1 s	Check the system parameters
-----------	-----------------------------

**MODEL DESCRIPTION**

MODEL	DESCRIPTION
13.4 HP	13.4 SEER heat exchanger package unit

**CODE DESCRIPTION**

CC	Compressor Contactor
COMP.	Compressor
CCH	Crankcase Heater
T4	Ambient Temperature Sensor
T3	Pipe Temperature Sensor
HPC	High Pressure Cut-out Control
LPC	Low Pressure Cut-out Control
DTS	Discharge Temperature Switch
OFM	Outdoor Fan Motor
IFM	Indoor Fan Motor
RC	Run Capacitor
RV	Reversing Valve

CODE	FAULT DESCRIPTION
E3	T3 sensor fault
E4	T4 sensor fault
E8	Capacity setting no set
E9	R110 resistor or drive chip software fault
P2	LPC protection
P4	Discharge temperature protection
P5	T3 high-temperature protection
AL	Ambient temperature limitation
H0	Communication fault between drive chip and main control chip
n1X	OFM overcurrent protection
n2X	Drive module overtemperature protection
n3X	DC bus voltage fault
n4X	IPM Fault
n5X	OFM startup fault
n6X	Phase loss protection

"n" serial faults, alternately display n and xx

NUMBER	POINT CHECK CONTENT
1	Unit capacity
2	Operation mode
3	Current fan speed (Actual speed divided by 10, for example, 580R is represented by '58', 1050R is represented by 'A5', hexadecimal number A represents 10.)
4	Target fan speed (Target speed divided by 10, for example, 560R is represented by '56', 1050R is represented by 'A5', hexadecimal number A represents 10.)
5	T3 temperature (°F) (if the value is less than 100, the actual value is displayed, if over 100, divided by 10, 135 is represented by '13', if it is negative, '1.0' means -10, '.5' means -5)
6	T4 temperature (°F) (if the value is less than 100, the actual value is displayed, if over 100, divided by 10, 135 is represented by '13', if it is negative, '1.0' means -10, '.5' means -5)
7	Compressor running time (day) (if the value is less than 100, the actual number of days is displayed, if over 100 and less than 1000, 360 days are represented by '36', if over 1000, 3600 days are represented by '3.6'.)
8	Main control chip software version
9	Drive chip software version
10	Y signal state (1=ON, 0=OFF)
11	B signal state (1=ON, 0=OFF)
12	W1 signal state (1=ON, 0=OFF)
13	W2 signal state (1=ON, 0=OFF)
14	RV (4-Way Valve) condition (1=ON, 0=OFF)
15	High fan speed mode (1=ON, 0=OFF)
16	Last fault code
17	Last second fault code
18	Last third fault code
19	-

Factory code	Date	Revision
1602770003457	Sep. 28th, 2024	B

**WARNING!**  
 Cabinet must be permanently earthed, and all wiring conform to UL60335.  
 Replacement wires must be the same gauge and insulation type as original wires.

THE WIRING DIAGRAM SHOWN IS FOR REFERENCE ONLY. IT MAY BE DIFFERENT FROM THE ACTUAL PRODUCT.

# HP System Wiring Diagram (42/48K)

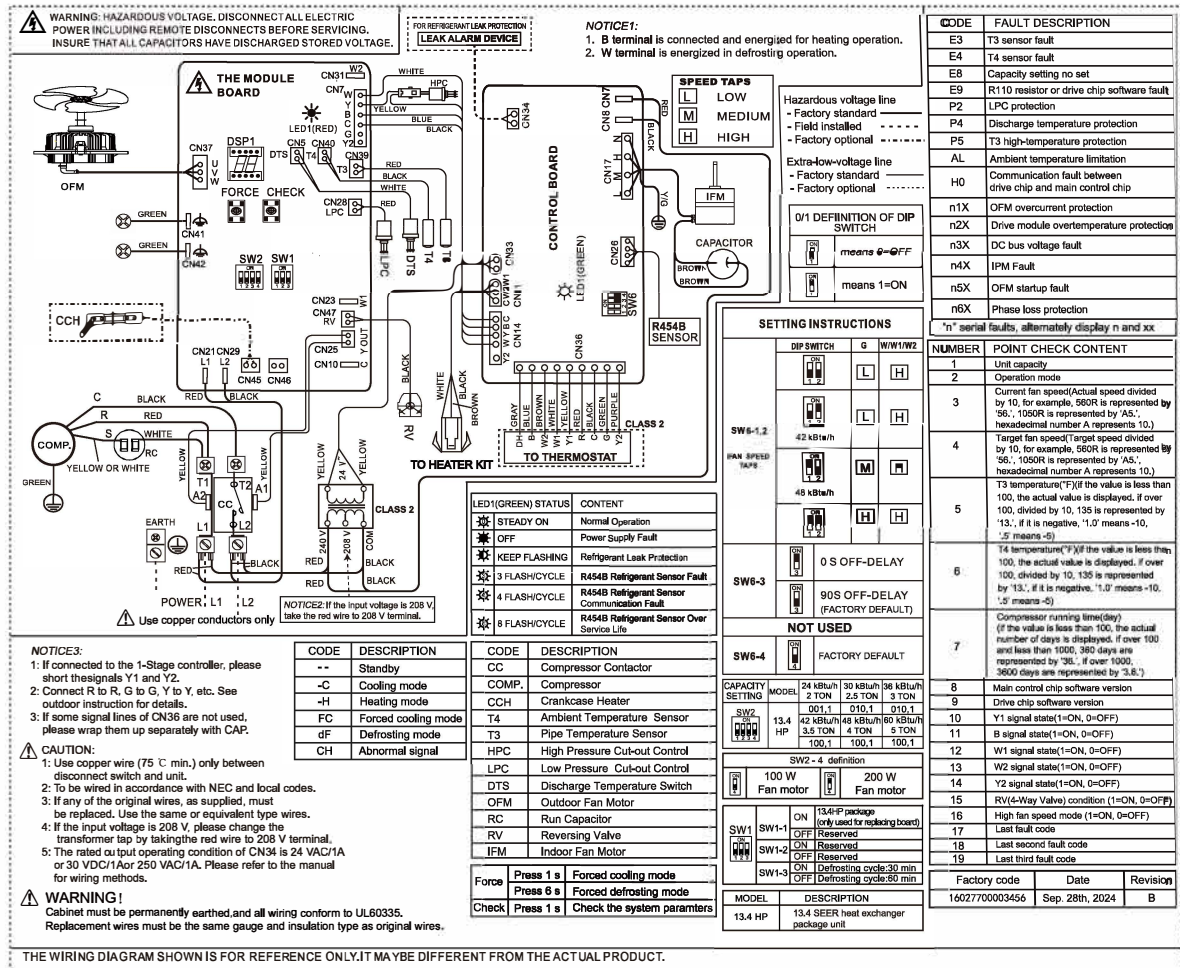

# HP System Wiring Diagram (60K)

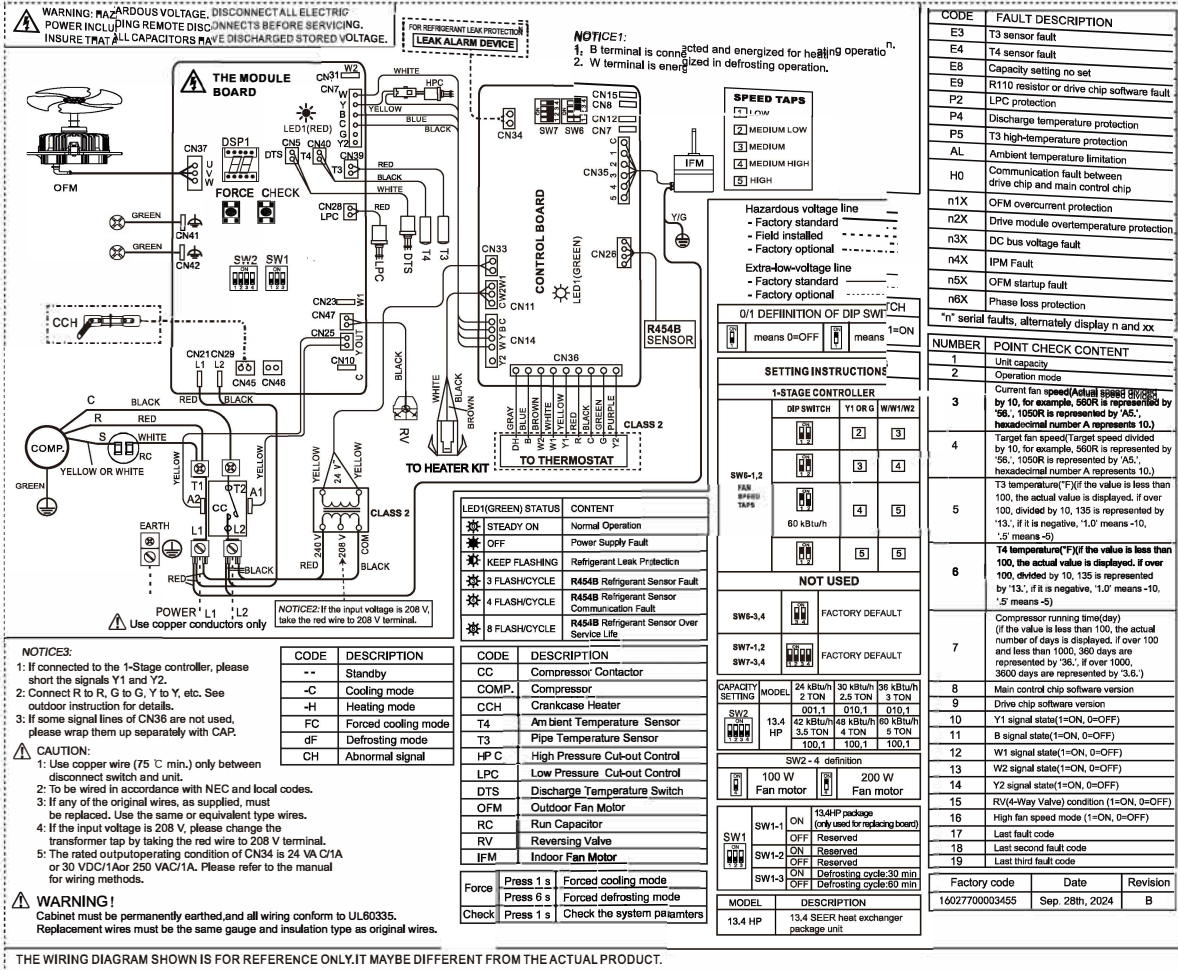

## 12 DISPOSAL

Comply with national regulations.

Components and accessories from the units are not part of ordinary domestic waste.

Complete units, compressors, motors etc. are only to be disposed of via qualified disposal specialists.

This unit uses flammable refrigerant R454B. Please contact the dealer when you want to dispose of this unit. Law requires that the collection, transportation and disposal of refrigerants must conform with the regulations governing the collection and destruction of hydrofluorocarbons.



16127700A10865 V.A