

# ComfortStar®

Air Conditioning & Heating Products

## Service Manual

### Indoor Unit:

AC32-4860C-15(42T)

AC32-4860D-15(42U)

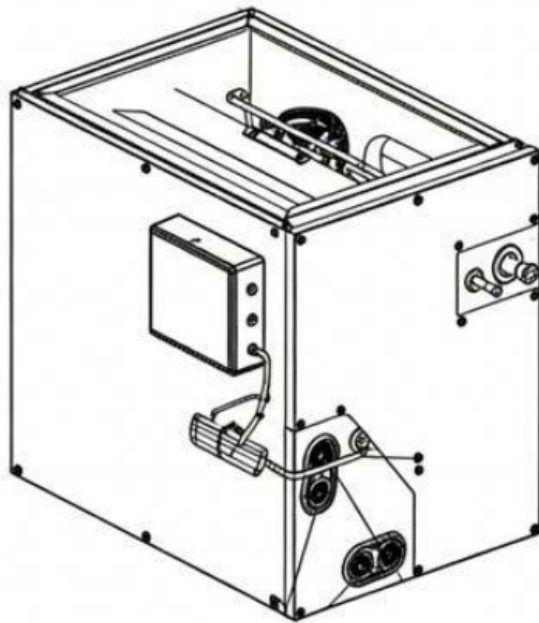

**A** RECOGNIZE THIS SYMBOL AS A SAFETY PRECAUTION

#### ATTENTION INSTALLING PERSONNEL

Prior to installation, thoroughly familiarize yourself with this Installation Manual. Observe all safety warnings.

During installation or repair, caution is to be observed.

It is your responsibility to install the product safely and to educate the customer on its safe use.

Eair LLC

12201 N.W. 107<sup>th</sup> Avenue, Medley, FL 33178

[www.comfortstarusa.com](http://www.comfortstarusa.com)

# Part 1

## General Information

|                                      |   |
|--------------------------------------|---|
| 1 Product lineup .....               | 2 |
| 2 Specifications .....               | 3 |
| 3 Dimensional drawings .....         | 4 |
| 4 Layout Functional Components ..... | 5 |

**1 Product lineup**

| Model         | Cooling Capacity (Btu/h) | Appearance   |
|---------------|--------------------------|--|
| AC32-1824B-15 | 18000/24000              |    |
| AC32-3036B-15 | 30000/35000              |    |
| AC32-3036C-15 | 30000/35000              |   |
| AC32-4860C-15 | 46000/54000              |  |
| AC32-4860D-15 | 46000/54000              |  |

## 2 Specification

| Model                | Indoor unit                  |           | AC32-1824B-15             | AC32-3036B-15              | AC32-3036C-15             | AC32-4860C-15             | AC32-4860D-15          |
|----------------------|------------------------------|-----------|---------------------------|----------------------------|---------------------------|---------------------------|------------------------|
| Power supply         |                              | V, Ph, Hz | 208/230, 1, 60            | 208/230, 1, 60             | 208/230, 1, 60            | 208/230, 1, 60            | 208/230, 1, 60         |
| Cooling              | Rated Capacity               | Btu/hr    | 18000/24000               | 30000/35000                | 30000/35000               | 46000/54000               | 46000/54000            |
| Indoor coil          | Number of rows               |           | 3                         | 4                          | 4                         | 5                         | 5                      |
|                      | Tube OD                      | inch      | 9/32                      | 9/32                       | 9/32                      | 9/32                      | 9/32                   |
| Indoor Unit          | Unit Demension(W*D*H)        | inch      | 17-33/64*21-1/32*17-63/64 | 17-33/64*21-1/32*23-37/64  | 21-1/32*21-1/32*23-37/64  | 21-1/32*21-1/32*27-51/64  | 24-31/64-1/32*27-51/64 |
|                      | Packing Demension(W*D*H)     | inch      | 20-15/32*26-49/64*20-5/64 | 20-15/32*26-49/64*25-63/64 | 24-1/64*26-49/64*26-63/64 | 24-1/64*26-49/64*29-59/64 | 27-9/16-49/64*29-59/64 |
|                      | Net/Gross Weight             | lbs       | 42/50                     | 59.5/68                    | 64/74                     | 81/92                     | 97/115                 |
| Refrigerant pipe     | Liquid side/Gas side         | inch      | (3/8) / (3/4)             | (3/8) / (3/4)              | (3/8) / (3/4)             | (3/8) / (3/4)             | (3/8) / (3/4)          |
|                      | Max. refrigerant pipe length | feet      | 131                       | 131                        | 131                       | 246                       | 246                    |
|                      | Max. difference in level     | feet      | 65.6                      | 98                         | 98                        | 98                        | 98                     |
| Indoor(Setting Tem.) | Cooling                      |           | 60-90                     | 60-90                      | 60-90                     | 60-90                     | 60-90                  |
|                      | Heating                      |           | /                         | /                          | /                         | /                         | /                      |

3 Dimensional drawings

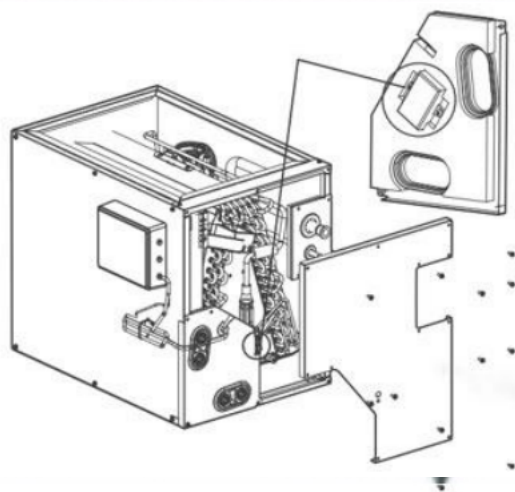
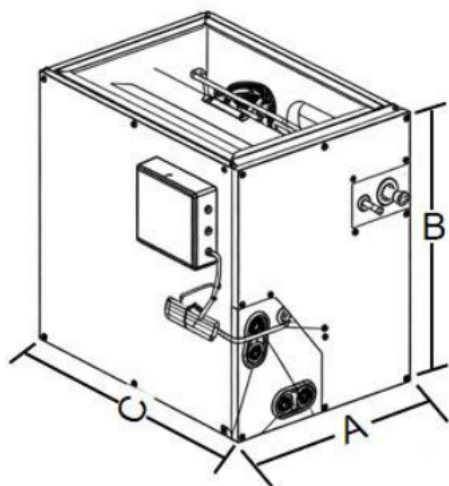

| Dimensions |              | Model | AC32-1824B-15 |     | AC32-3036B-15 |     | AC32-3036C-15 |     |
|------------|--------------|-------|---------------|-----|---------------|-----|---------------|-----|
|            |              |       | inch          | mm  | inch          | mm  | inch          | mm  |
| A          | Model Width  |       | 17-63/64      | 457 | 23-37/64      | 599 | 23-37/64      | 599 |
| B          | Model Height |       | 17-33/64      | 445 | 17-33/64      | 445 | 21-1/32       | 534 |
| C          | Model Deep   |       | 21-1/32       | 534 | 21-1/32       | 534 | 21-1/32       | 534 |
| Dimensions |              | Model | AC32-4860C-15 |     | AC32-4860D-15 |     |               |     |
|            |              |       | inch          | mm  | inch          | mm  |               |     |
| A          | Model Width  |       | 27-51/64      | 706 | 24-31/64      | 706 |               |     |
| B          | Model Height |       | 21-1/32       | 534 | 27-51/64      | 622 |               |     |
| C          | Model Deep   |       | 21-1/32       | 534 | 21-1/32       | 534 |               |     |

### 4 Layout Functional Components

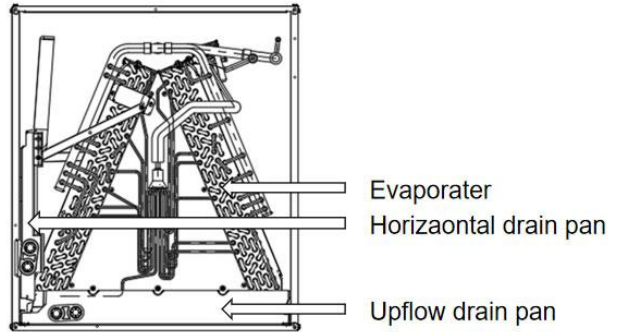
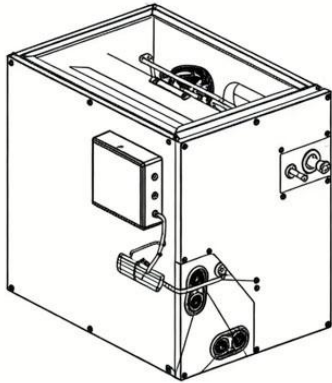

## Part 2

# Wiring Diagram

|                                    |    |
|------------------------------------|----|
| 1 Electric wiring diagram .....    | 7  |
| 2 PCB .....                        | 9  |
| 3 Low voltage wiring diagram ..... | 10 |
| 4 Electrical parameters .....      | 14 |

1 Electric wiring diagram

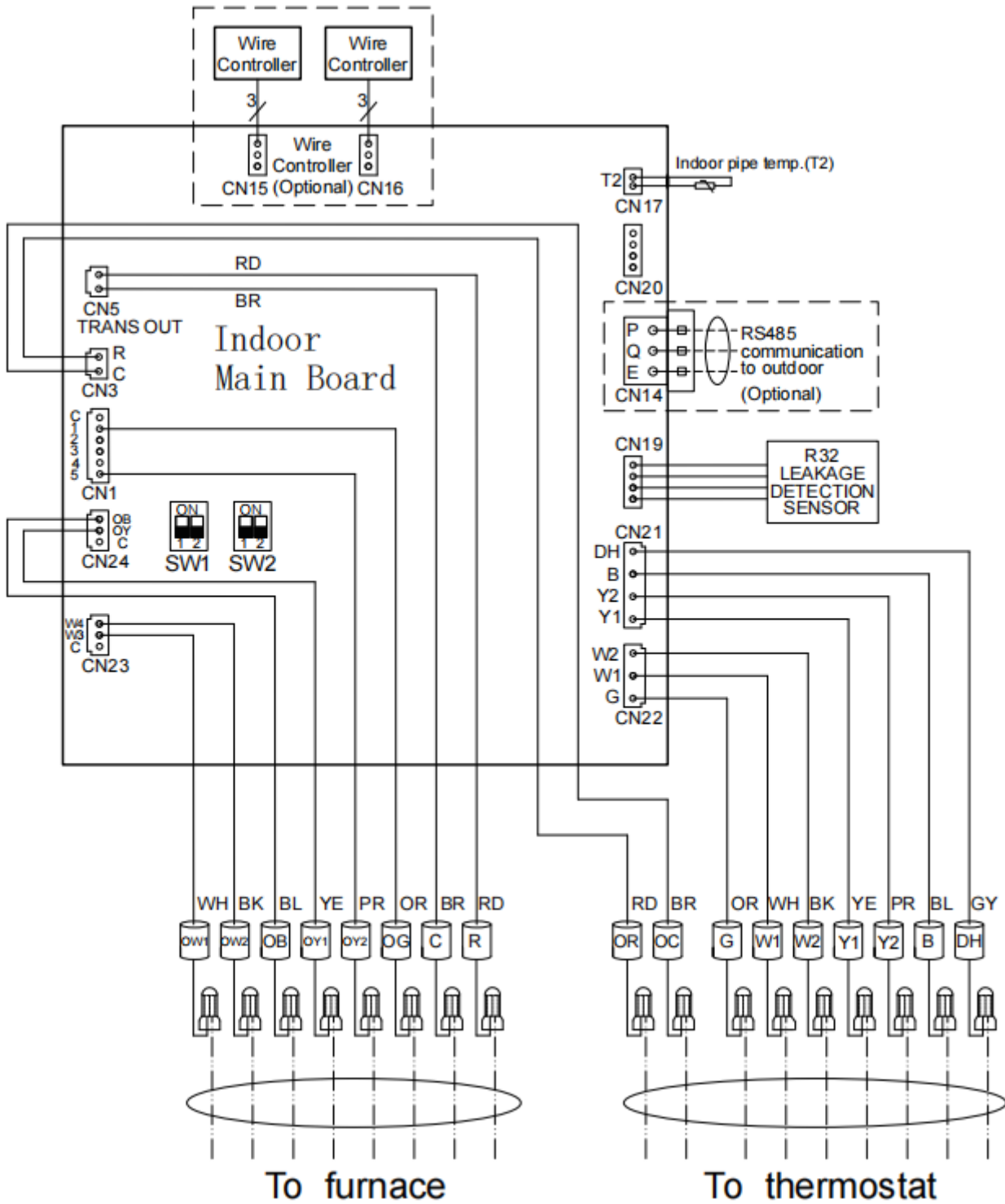

| DIP switch status Indicate             |   |   |
|--|---|---|
| ON <input type="checkbox"/>            | OFF <input checked="" type="checkbox"/> | This Indicate OFF<br>( The DIP switch is dialed to the digital side)    |
| 1                                      |   |   |
| ON <input checked="" type="checkbox"/> | OFF <input type="checkbox"/>            | This Indicate ON<br>( The DIP switch is dialed to the non-digital side) |
| 1                                      |   |   |
| SW1 DIP switch selection               |   |   |
| SW1.1                                  | SW1.2                                   | Reserve   |
| OFF                                    | OFF                                     | Reserve (Default)   |
| OFF                                    | ON                                      | Reserve   |
| ON                                     | OFF                                     | Reserve   |
| ON                                     | ON                                      | Reserve   |
| SW2 DIP switch selection               |   |   |
| SW2.1                                  | OFF                                     | 24V Control(Default)  |
|  | ON                                      | RS485 Comm. Mode  |
| SW2.2                                  | OFF                                     | Anti-Cold Air Delay(Default)  |
|  | ON                                      | Disable Anti-Cold Air Delay   |

| Wire Color Code   |                    |                |
|-------------------|--------------------|----------------|
| RD RED            | OR ORANGE          |                |
| BL BLUE           | PK PINK            |                |
| BR BROWN          | GY GRAY            |                |
| BK BLACK          | YE YELLOW          |                |
| WH WHITE          | PR PURPLE          |                |
| WH/BK             | WHITE BLACK STRIPE |                |
| LINE ANNOTATION   |                    |                |
| —————             | Factory wiring     |                |
| -----             | Field install      |                |
| - - - - -         | Dashed box         |                |
| INTERFACE VOLTAGE |                    |                |
| CN5               | R / C              | Input : 24VAC  |
| CN21              | Y1 / Y2 / B / DH   | Input : 24VAC  |
| CN22              | G / W1 / W2        | Input : 24VAC  |
| CN1               | OG / OY2           | Output : 24VAC |
| CN3               | OR / OC            | Output : 24VAC |
| CN23              | OW1 / OW2          | Output : 24VAC |
| CN24              | OY / OB            | Output : 24VAC |
| CN14              | P / Q / E          | Output : 5VDC  |

2 PCB

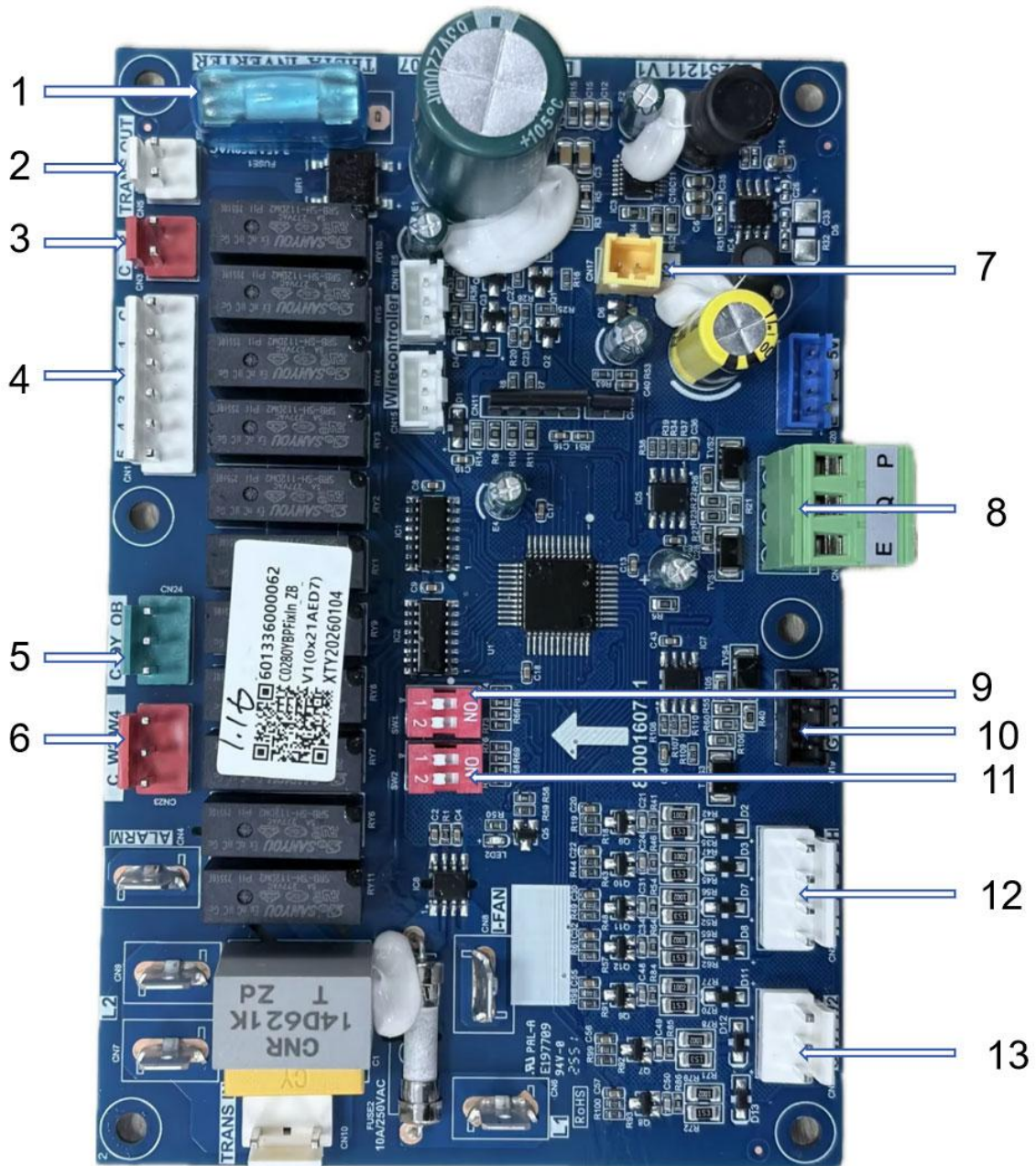

| No. | Port Names and Definitions                 | No. | Port Names and Definitions                 |
|-----|--|-----|--|
| 1   | Fuse                                       | 10  | Port for refrigerant concentration monitor |
| 2   | 24V trans in from transformer              | 11  | DIP Switch-SW2                             |
| 3   | Port to 24V thermostat(R/C)                | 12  | Port to 24V thermostat(DH/B/Y2/Y1)         |
| 4   | Control Device for Furnace                 | 13  | Port to 24V thermostat(W2/W1/G)            |
| 5   | Rapid heating mode                         |     |  |
| 6   | Port to furnace thermostat(W2/W1/G)        |     |  |
| 7   | Port for indoor coil temperature sensor T2 |     |  |
| 8   | RS-485 communication port to outdoor       |     |  |
| 9   | DIP Switch-SW1                             |     |  |

### 3 Low voltage wiring diagram

The following wiring diagram are suitable for the Indoor Unit and Outdoor Unit with 24V thermostat.

Note1: Any time the electric heat elements are active. the indoor fan will run in high stage.

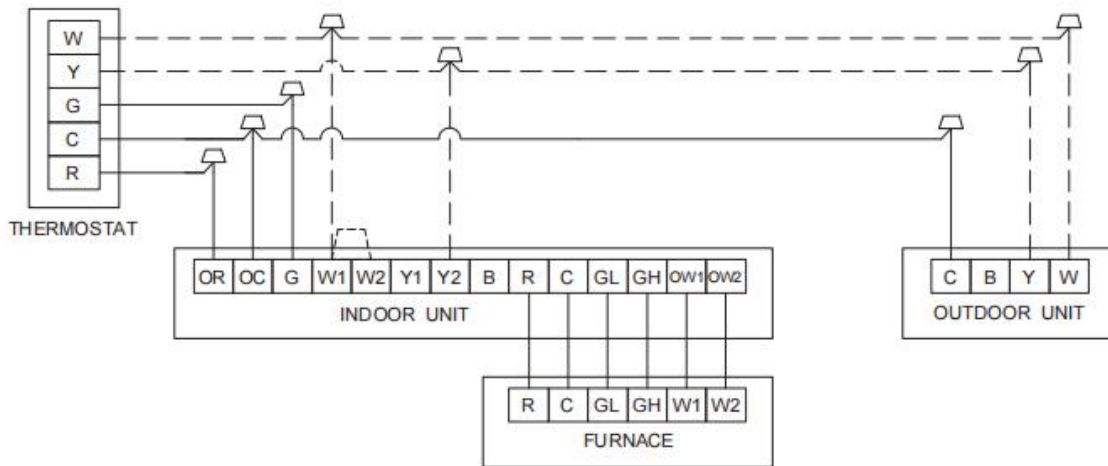

### Wiring for 1H and 1C thermostat

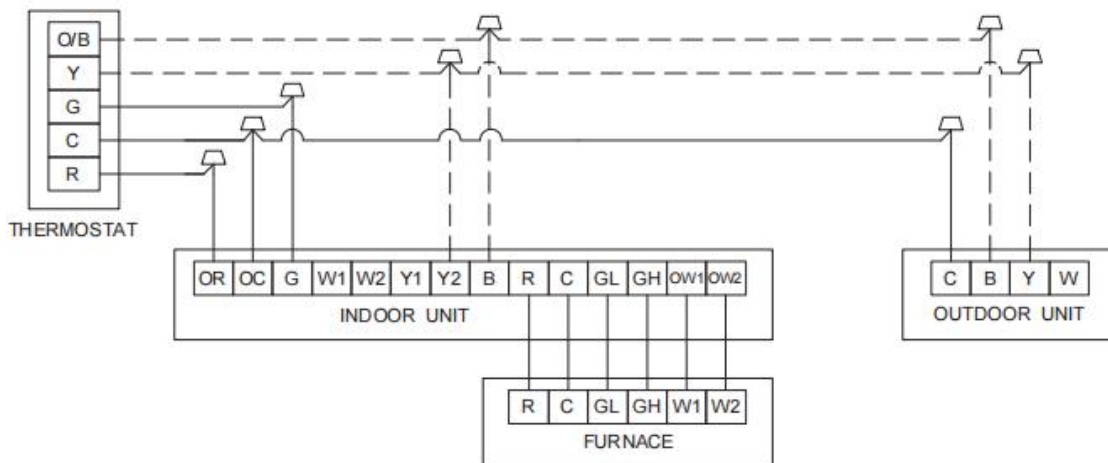

Note1: Any time the electric heat elements are active. the indoor fan will run in high stage.

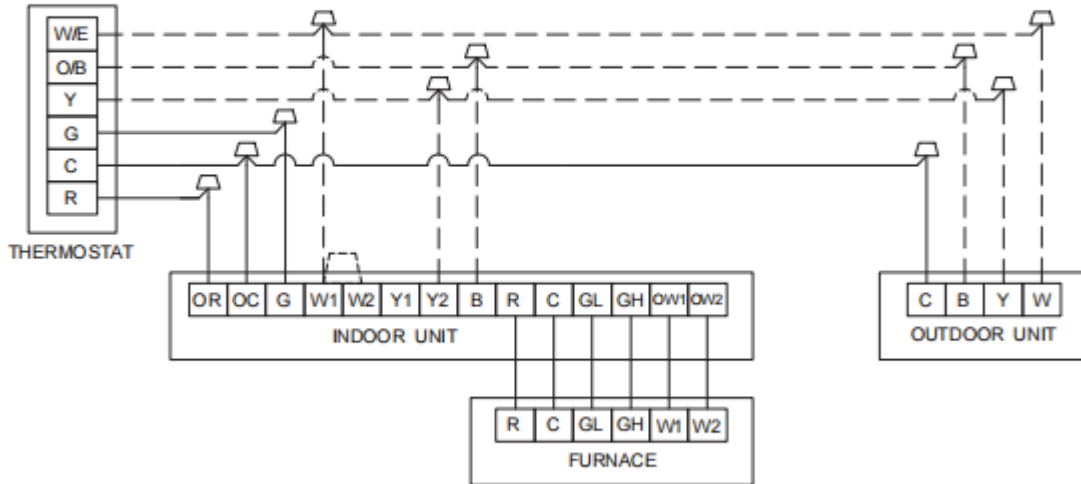

### Wiring for 2H and 2C thermostat

Note1: Y1 and Y2 here represents 2 stages of fan cooling only, the compressor modulates separately from the fan.

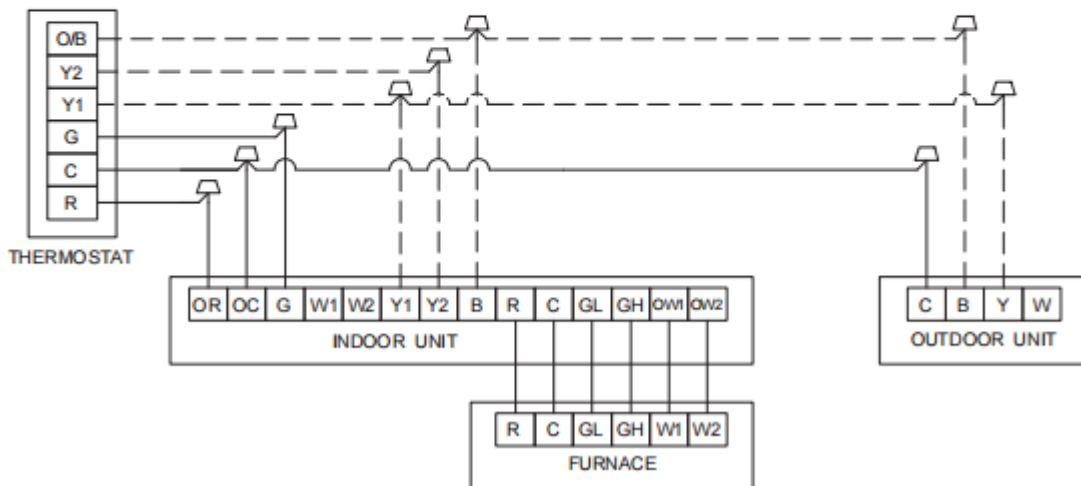

The following wiring diagram are suitable for the Indoor Unit and Outdoor Unit with RS485 communication.

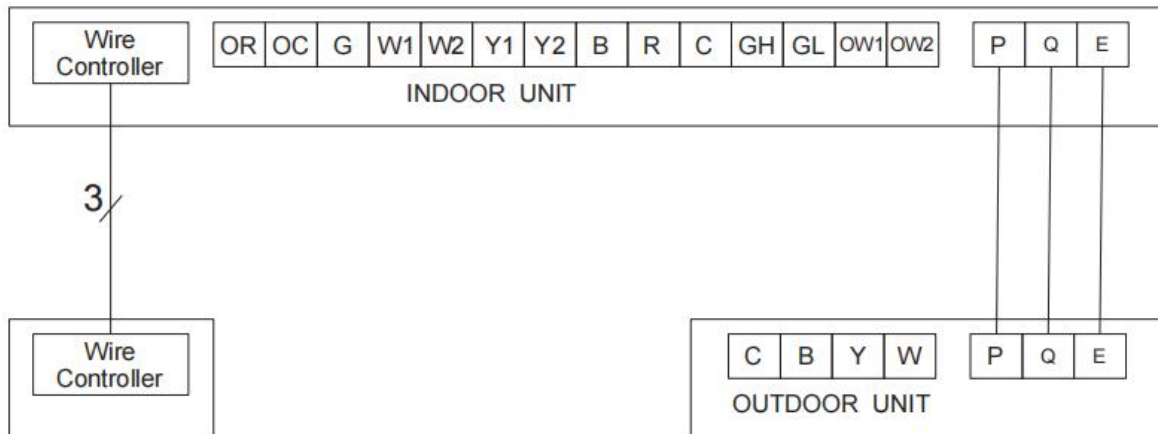

**Control Logic:**

| Connector | Usage   |
|-----------|---|
| R         | Provides 24VAC power from the furnace to the board.   |
| C         | The 24VAC common wire between the furnace and the board.  |
| OW1       | First stage of furnace command line from the board to the furnace (OW1-W1).If the furnace that only have a W and do not have a W2, connect OW1 to the W of the furnace and make no connection with the OW2 signal wire (OW1-W).   |
| OW2       | Second stage of furnace command line from the board to the furnace (OW2-W2). OW2 cannot be ON unless OW1 is already ON.   |
| GL        | Connect the GL signal to G of the furnace (GL-G).If the furnace that do not have a G, connect GL to the Y or Y1 of the furnace (GL-Y or GL-Y1).   |
| GH        | For 2-speed configuration, connect the GH signal to Y2 of the furnace (GH-Y2).<br>In this configuration, the GL signal turns on as follows:<br>- In Cool mode or Heat mode with HP when high speed fan is requested.<br>- In Auto Fan and Cool mode, the signal goes to high speed when the difference between room temperature and set point temperature is more than or equal to 1.5°C. The signal goes back to low speed when the temperature difference is less than 1°C.<br>- In Auto Fan and Heat mode with the HP, the signal goes to high speed when the difference between room temperature and set point temperature is less than or equal to -1.5°C. The signal goes back to low speed when the temperature difference is more than 0°C. |

**Note:**

- 1) DH wiring is optional and requires a thermostat with a humidistat. DH functions as Passive Dehumidification and will downstage the indoor fan to first stage. System will operate according to normal sequence of operations if DH wiring is absent.
- 2) Dashed lines in the above thermostat wiring diagrams refer to optional wiring (wiring for Passive Dehumidification Function and/OR Electric Heat). For thermostat wiring please refer to the Owner's Manual of the thermostat.
- 3) B wire must be used with heat pump system only, the reversing valve energizes in heating.

### 4 Electrical parameters

| Capacity(Btu/h) |                    | 18K                   | 24K                   | 30K                   | 36K                   | 48K                   | 60K                   |
|-----------------|--------------------|-----------------------|-----------------------|-----------------------|-----------------------|-----------------------|-----------------------|
| Power           | Phase              | 1                     | 1                     | 1                     | 1                     | 1                     | 1                     |
| (Indoor)        | Frequency and Volt | 208/230,60Hz          |                       |                       |                       |                       |                       |
| Power           | Phase              | 1                     | 1                     | 1                     | 1                     | 1                     | 1                     |
| (Outdoor)       | Frequency and Volt | 208/230,60Hz          |                       |                       |                       |                       |                       |
| Max.Fuse        | Indoor unit(A)     | 0,3                   | 0,3                   | 0,3                   | 0,3                   | 0,3                   | 0,3                   |
|                 | Outdoor unit(A)    | 15                    | 20                    | 25                    | 30                    | 40                    | 50                    |
| Indoor unit     | Line quantity      | 3                     | 3                     | 3                     | 3                     | 3                     | 3                     |
| Powerline       | Line diameter(AWG) | 20/0,5mm <sup>2</sup> | 20/0,5mm <sup>2</sup> | 20/0,5mm <sup>2</sup> | 20/0,5mm <sup>2</sup> | 20/0,5mm <sup>2</sup> | 20/0,5mm <sup>2</sup> |
| Outdoor unit    | Line quantity      | 3                     | 3                     | 3                     | 3                     | 3                     | 3                     |
| Powerline       | Line diameter(AWG) |                       |                       |                       |                       |                       |                       |
| Outdoor unit    | Line quantity      | 3                     | 3                     | 3                     | 3                     | 3                     | 3                     |
| Signal line     | Line diameter(AWG) | 20/0,5mm <sup>2</sup> | 20/0,5mm <sup>2</sup> | 20/0,5mm <sup>2</sup> | 20/0,5mm <sup>2</sup> | 20/0,5mm <sup>2</sup> | 20/0,5mm <sup>2</sup> |
| Thermostat      | Line quantity      | /                     | /                     | /                     | /                     | /                     | /                     |
| Signal line     | Line diameter(AWG) | 18/0,8mm <sup>2</sup> | 18/0,8mm <sup>2</sup> | 18/0,8mm <sup>2</sup> | 18/0,8mm <sup>2</sup> | 18/0,8mm <sup>2</sup> | 18/0,8mm <sup>2</sup> |

# Part 3

## Diagnosis and Troubleshooting

- 1 Error code table ..... 16
- 2 Troubleshooting ..... 17
  - 2.1 Safety Precautions .....17
  - 2.2 T2 temperature sensor fault troubleshooting ..... 20
  - 2.3 Refrigerant concentration sensor fault troubleshooting ..... 21
  - 2.4 Refrigerant leakage protection troubleshooting ..... 22
  - 2.5 Anti-freeze protection troubleshooting ..... 23
  - 2.6 Wired controller communication error troubleshooting .....24
- 3. Temperature Sensor Resistance Characteristics ..... 25

### 1 Error code table

| Error code                         | Error definition                           |
|------------------------------------|--|
| Flash for 3 times every 8 seconds  | T2 temperature sensor fault                |
| Flash for 4 times every 8 seconds  | R32 refrigerant concentration sensor fault |
| Flash for 5 times every 8 seconds  | R32 refrigerant leakage protection         |
| Flash for 6 times every 8 seconds  | Anti-freeze protection                     |
| Flash for 10 times every 8 seconds | Wired controller communication error       |

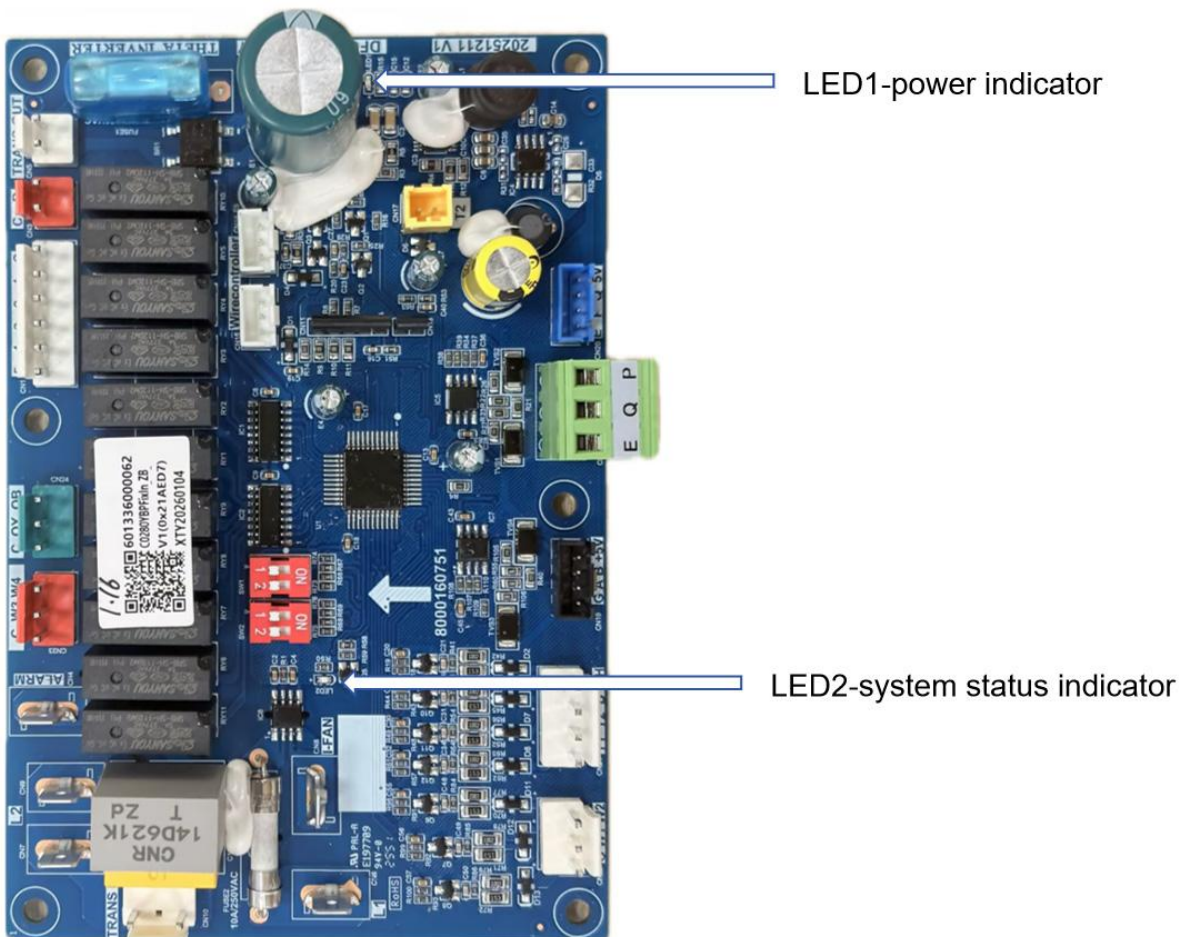

**Note:** In normal operation, LED1 and LED2 are steady on; when the system is standby, LED1 will be steady on, LED2 will flash slowly.

## 2 Troubleshooting

### 2.1 Safety Precautions

The following precautions here are quite important, so be sure to follow them carefully. Read these instructions carefully before installation. Keep this manual in a handy for future preference.

Failure to adhere to all precautionary measures listed in this section may result in personal injury, damage to the unit or to property, or in extreme cases, death.



#### WARNING

- Indicates a potentially hazardous situation which if not avoided, could result in death or serious injury.



#### CAUTION

- Indicates a potentially hazardous situation which if not avoided, may result in minor or moderate injury.
- It is also used to alert against unsafe practices.

#### 2.1.1 In case of Accidents or Emergency



#### WARNING

- If a gas leak is suspected, immediately turn off the gas and ventilate the area if a gas leak is suspected before turning the unit on.
- If strange sounds or smoke is detected from the unit, turn the breaker off and disconnect the power supply cable.
- If the unit comes into contact with liquid, contact an authorized service center.
- If liquid from the batteries makes contact with skin or clothing, immediately rinse or wash the area well with clean water.
- Do not insert hands or other objects into the air inlet or outlet while the unit is plugged in.
- Do not operate the unit with wet hands.



#### CAUTION

- Clean and ventilate the unit at regular intervals when operating it near a stove or near similar devices.
- Do not use the unit during severe weather conditions. If possible, remove the product from the window before such occurrences.

### 2.1.2 Information servicing(For flammable materials)



#### WARNING

---

- Use this unit only on a dedicated circuit.
- Damage to the installation area could cause the unit
- to fall, potentially resulting in personal injury, property damage, or product failure.
- Only qualified personnel should disassemble, install, remove, or repair the unit.
- Only a qualified electrician should perform electrical work. For more information, contact your dealer, seller, or an authorized service center.



#### CAUTION

---

- While unpacking be careful of sharp edges around the unit as well as the edges of the fins on the condenser and evaporator.

### 2.1.3 Operation and Maintenance



#### WARNING

---

- Do not use defective or under-rated circuit breakers.
- Ensure the unit is properly grounded and that a dedicated circuit and breaker are installed.
- Do not modify or extend the power cable. Ensure the power cable is secure and not damaged during operation.
- Do not unplug the power supply plug during operation.
- Do not store or use flammable materials near the unit.
- Do not open the inlet grill of the unit during operation.
- Do not touch the electrostatic filter if the unit is equipped with one.
- Do not block the inlet or outlet of air flow to the unit.
- Do not use harsh detergents, solvents, or similar items to clean the unit. Use a soft cloth for cleaning.
- Do not touch the metal parts of the unit when removing the air filter as they are very sharp.
- Do not step on or place anything on the unit or outdoor units.
- Do not drink water drained from the unit.
- Avoid direct skin contact with water drained from the unit.

- Use a firm stool or step ladder according to manufacturer procedures when cleaning or maintaining the unit.

**CAUTION**

---

- Do not install or operate the unit for an extended period of time in areas of high humidity or in an environment directly exposing it to sea wind or salt spray.
- Do not install the unit on a defective or damaged installation stand, or in an unsecured location.
- Ensure the unit is installed at a level position
- Do not install the unit where noise or air discharge
- Created by the outdoor unit will negatively impact the environment or nearby residences.
- Do not expose skin directly to the air discharged by the unit for prolonged periods of time.
- Ensure the unit operates in areas waterOr other liquids.
- Ensure the drain hose is installed correctly to ensure proper water drainage.
- When lifting or transporting the unit, it is recommended that two or more people are used for this task.
- When the unit is not to be used for an extended time, disconnect the power supply or turn off the breaker.

### 2.2 T2 temperature sensor fault troubleshooting

- LED2 flashes for 3 times every 8 seconds indicates indoor unit T2 temperature sensor fault
- The unit stops running and LED2 flashes 2 or 3 times in each round.

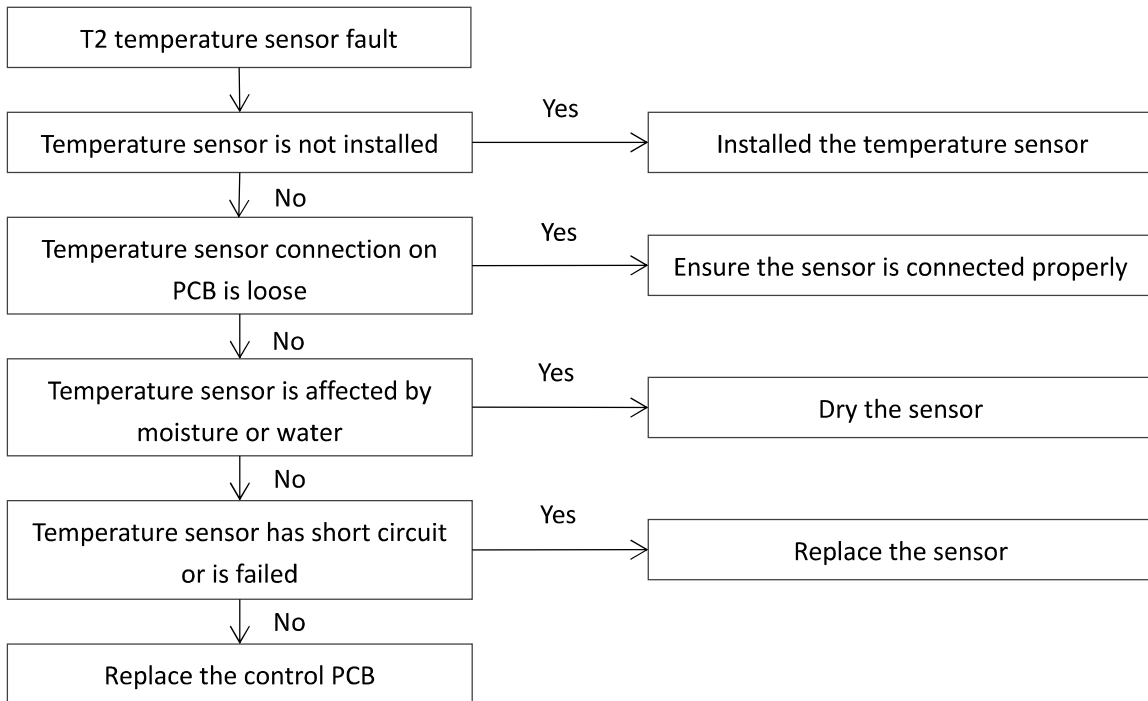

Note: Measure sensor resistance. If the resistance is too low, the sensor has short-circuited. If the resistance is not consistent with the sensor’s resistance characteristics table, the sensor has failed.

### 2.3 Refrigerant concentration sensor fault troubleshooting

- LED2 flash for 4 times every 8 seconds indicates refrigerant concentration sensor fault (Only valid when connected to a refrigerant concentration sensor.)
- The unit stops running and LED2 flashes 4 times in each round.

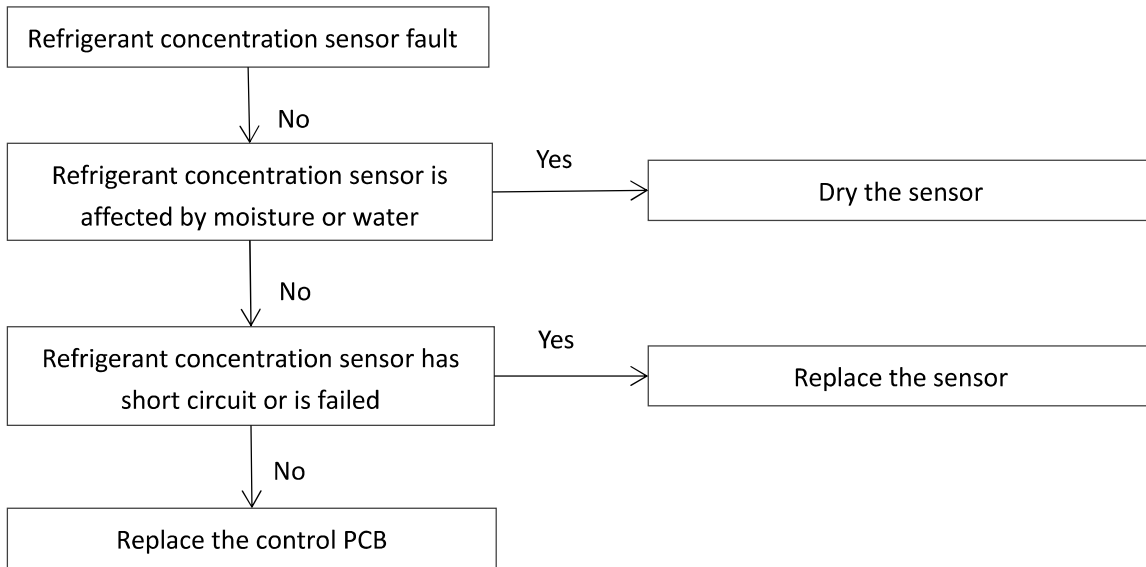

### 2.4 Refrigerant leakage protection troubleshooting

- LED2 flashes for 5 times every 8 seconds indicates refrigerant leakage protection (Only valid when connected to a refrigerant concentration sensor.)
- The unit stops running and error code is displayed on LED2 flashes 5 times in each round.

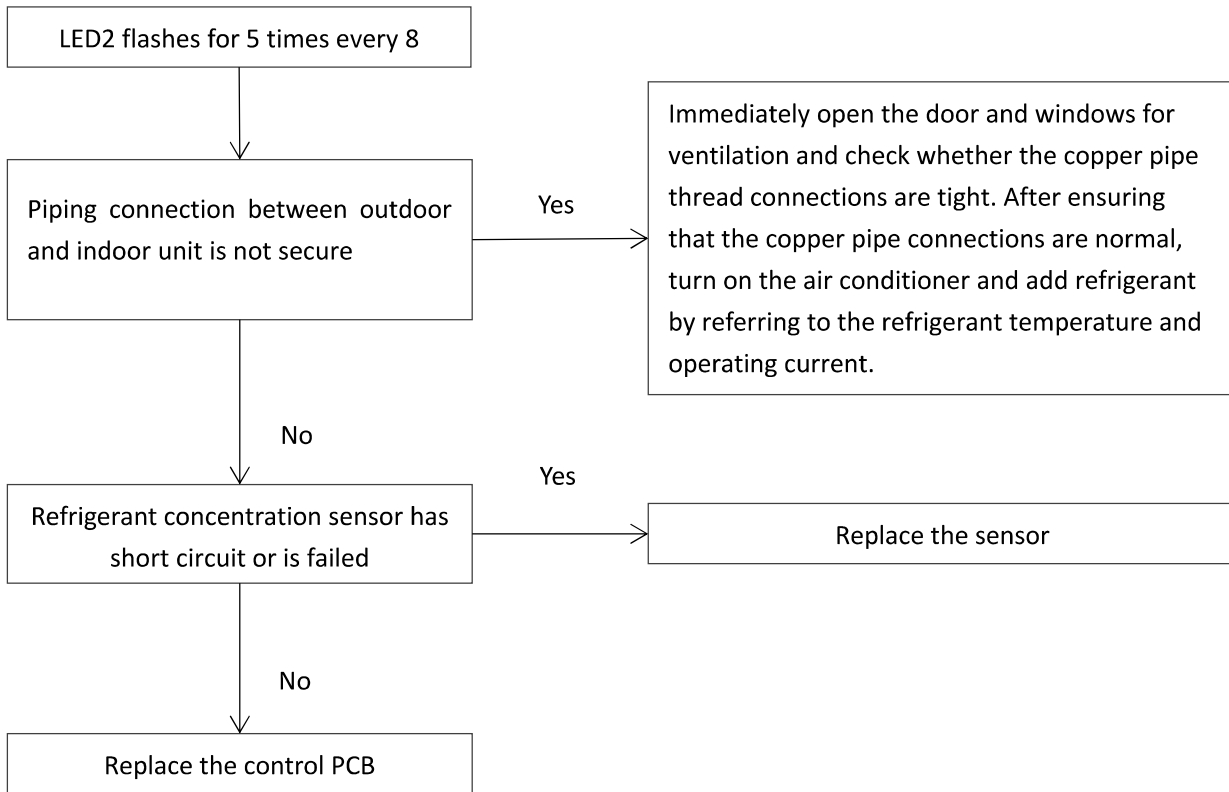

Note:

- 1) Measure sensor resistance. If the resistance is too low, the sensor has short-circuited. If the resistance is not consistent with the sensor’s resistance characteristics table, the sensor has failed.

### 2.5 Anti-freeze protection troubleshooting

- LED2 flashes 6 times every 8 seconds indicates anti-freeze protection.
- The unit stops running and LED2 flashes 6 times in each round.

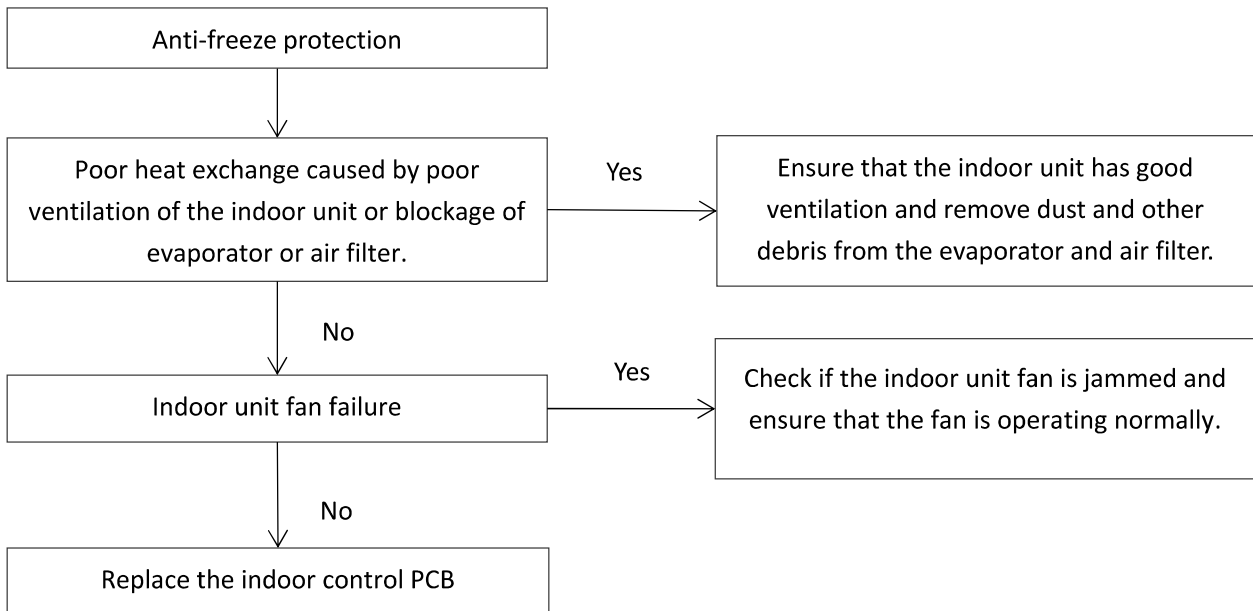

### 2.6 Wired controller communication error troubleshooting

- LED2 flashes 10 times every 8 seconds indicates wired controller communication error.
- The unit stops running and LED2 flashes 10 times in each round.

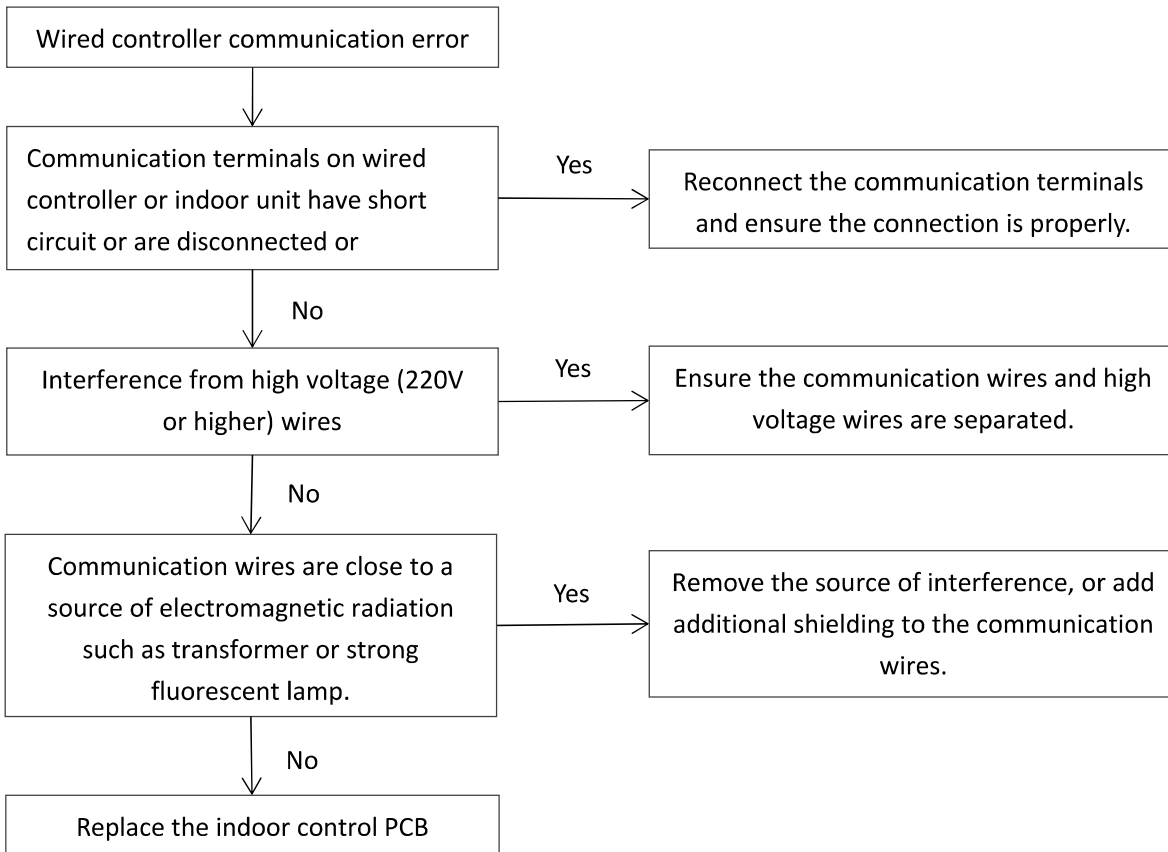

### 3. Temperature Sensor Resistance Characteristics

Condenser coil temperature sensor(T2) resistance characteristics.

| Temperature (°C) | Temperature (°F) | Resistance (kQ) | Temperature (°C) | Temperature (°F) | Resistance (kQ) |
|------------------|------------------|-----------------|------------------|------------------|-----------------|
| -25              | -13              | 144.266         | 15               | 59               | 16.079          |
| -24              | -11              | 135.601         | 16               | 61               | 15.313          |
| -23              | -9               | 127.507         | 17               | 63               | 14.588          |
| -22              | -8               | 119.941         | 18               | 64               | 13.902          |
| -21              | -6               | 112.867         | 19               | 66               | 13.251          |
| -20              | -4               | 106.732         | 20               | 68               | 12.635          |
| -19              | -2               | 100.552         | 21               | 70               | 12.05           |
| -18              | 0                | 94.769          | 22               | 72               | 11.496          |
| -17              | 1                | 89.353          | 23               | 73               | 10.971          |
| -16              | 3                | 84.278          | 24               | 75               | 10.473          |
| -15              | 5                | 79.521          | 25               | 77               | 10              |
| -14              | 7                | 75.059          | 26               | 79               | 9.551           |
| -13              | 9                | 70.873          | 27               | 81               | 9.125           |
| -12              | 10               | 66.943          | 28               | 82               | 8.721           |
| -11              | 12               | 63.252          | 29               | 84               | 8.337           |
| -10              | 14               | 59.784          | 30               | 86               | 7.972           |
| -9               | 16               | 56.524          | 31               | 88               | 7.625           |
| -8               | 18               | 53.458          | 32               | 90               | 7.296           |
| -7               | 19               | 50.575          | 33               | 91               | 6.982           |
| -6               | 21               | 47.862          | 34               | 93               | 6.684           |
| -5               | 23               | 45.308          | 35               | 95               | 6.401           |
| -4               | 25               | 42.903          | 36               | 97               | 6.131           |
| -3               | 27               | 40.638          | 37               | 99               | 5.874           |
| -2               | 28               | 38.504          | 38               | 100              | 5.63            |
| -1               | 30               | 36.492          | 39               | 102              | 5.397           |
| 0                | 32               | 34.596          | 40               | 104              | 5.175           |
| 1                | 34               | 32.807          | 41               | 106              | 4.964           |
| 2                | 36               | 31.12           | 42               | 108              | 4.763           |
| 3                | 37               | 29.528          | 43               | 109              | 4.571           |
| 4                | 39               | 28.026          | 44               | 111              | 4.387           |
| 5                | 41               | 26.608          | 45               | 113              | 4.213           |
| 6                | 43               | 25.268          | 46               | 115              | 4.046           |
| 7                | 45               | 24.003          | 47               | 117              | 3.887           |
| 8                | 46               | 22.808          | 48               | 118              | 3.735           |
| 9                | 48               | 21.678          | 49               | 120              | 3.59            |
| 10               | 50               | 20.61           | 50               | 122              | 3.451           |
| 11               | 52               | 19.601          | 51               | 124              | 3.318           |
| 12               | 54               | 18.646          | 52               | 126              | 3.191           |
| 13               | 55               | 17.743          | 53               | 127              | 3.069           |
| 14               | 57               | 16.888          | 54               | 129              | 2.952           |

| Temperature(°C) | Temperature(°F) | Resistance(kΩ) | Temperature(°C) | Temperature(°F) | Resistance(kΩ) |
|-----------------|-----------------|----------------|-----------------|-----------------|----------------|
| 55              | 131             | 2.841          | 95              | 171             | 0.708          |
| 56              | 133             | 2.734          | 96              | 173             | 0.686          |
| 57              | 135             | 2.632          | 97              | 175             | 0.666          |
| 58              | 136             | 2.534          | 98              | 176             | 0.646          |
| 59              | 138             | 2.44           | 99              | 178             | 0.627          |
| 60              | 140             | 2.35           | 100             | 180             | 0.609          |
| 61              | 142             | 2.264          | 101             | 182             | 0.591          |
| 62              | 144             | 2.181          | 102             | 184             | 0.574          |
| 63              | 145             | 2.102          | 103             | 185             | 0.558          |
| 64              | 147             | 2.026          | 104             | 187             | 0.542          |
| 65              | 149             | 1.953          | 105             | 189             | 0.527          |
| 66              | 151             | 1.883          |                 |                 |                |
| 67              | 153             | 1.816          |                 |                 |                |
| 68              | 154             | 1.752          |                 |                 |                |
| 69              | 156             | 1.69           |                 |                 |                |
| 70              | 158             | 1.631          |                 |                 |                |
| 71              | 160             | 1.574          |                 |                 |                |
| 72              | 162             | 1.519          |                 |                 |                |
| 73              | 163             | 1.466          |                 |                 |                |
| 74              | 165             | 1.416          |                 |                 |                |
| 75              | 167             | 1.367          |                 |                 |                |
| 76              | 169             | 1.321          |                 |                 |                |
| 77              | 171             | 1.276          |                 |                 |                |
| 78              | 172             | 1.233          |                 |                 |                |
| 79              | 174             | 1.191          |                 |                 |                |
| 80              | 176             | 1.151          |                 |                 |                |
| 81              | 178             | 1.113          |                 |                 |                |
| 82              | 180             | 1.076          |                 |                 |                |
| 83              | 181             | 1.041          |                 |                 |                |
| 84              | 183             | 1.007          |                 |                 |                |
| 85              | 185             | 0.974          |                 |                 |                |
| 86              | 187             | 0.942          |                 |                 |                |
| 87              | 189             | 0.912          |                 |                 |                |
| 88              | 190             | 0.883          |                 |                 |                |
| 89              | 192             | 0.855          |                 |                 |                |
| 90              | 194             | 0.828          |                 |                 |                |
| 91              | 196             | 0.802          |                 |                 |                |
| 92              | 198             | 0.777          |                 |                 |                |
| 93              | 199             | 0.753          |                 |                 |                |
| 94              | 201             | 0.73           |                 |                 |                |