



ComfortStar® SUBMITTAL DATA SHEET

48000Btu/h	A-Coil
Location: _____ Engineer: _____ Submitted to: _____ Submitted by: _____ Reference: _____	Approval: _____ Date: _____ Construction: _____ Unit #: _____ Drawing #: _____

Set Model	
Indoor unit model	AC32-4860D-15(42U)
Outdoor unit model	BAR10-48-15(40L)
Certified AHRI  ETL 	



SYSTEM PERFORMANCE DATA		
Power supply		
Normal Operational Volt (V, Ph, Hz)		220-230V,1Ph, 60Hz
Voltage Range (V)		187-253
Electrical		
Minimum circuit ampacil (A)		27.0
Max.fuse (A)		40.0
Cooling		
Rated Capacity (Btu/h)		46000
Capacity Range (Btu/h)		/
Power Input (W)		3930
Rated current (A)		17.80
EER2 (Btu/W)		11.70
SEER2 (Btu/W)		13.8
Heating at 47F		
Rated Capacity (Btu/h)		/
Capacity Range (Btu/h)		/
Power Input (W)		/
Rated current (A)		/
HSPF4 (Btu/W)		/
HSPF5 (Btu/W)		/
COP	W/W	/
Heating at 5F		
Capacity (Btu/h)		/
COP	W/W	/
REFRIGERANT PIPE DATA		
Design pressure (PSIG)		609/174
Refrigerant Type		R32
Refrigerant charge (oz)		91.7
Additional charge (oz/ft)		0.5
	(g/m)	48.0
Liquid side/ Gas side (inch)		3/8" / 3/4"
	(mm)	Φ9.52 / Φ19
Max. pipe length (ft)		95.6
	(m)	246.0
Max. difference in level (ft)		95.6
	(m)	30.0
Connection method	Indoor	Braze
	Outdoor	Flared to braze
Indoor(cooling) (Deg. F)		60~90
Indoor(heating) (Deg. F)		/
Outdoor(cooling) (Deg. F)		23~125
Outdoor(heating) (Deg. F)		/

INDOOR UNIT DATA		
Throttle		TXV for Cooling
Indoor fan motor		
Type		---
Model		---
Qty		---
Input (W)		---
RLA (A)		---
LRA (A)		---
Capacitor (uF)		---
Speed(Hi/Mi/Lo) (r/min)		---
Air flow & Noise level		
Indoor air flow (Hi/Med/Lo) (CFM)		---
Indoor noise level (Hi/Med/Lo) [dB(A)]		---
Dehumidification (Pint/H) ---		
Indoor unit		
Dimension (WxDxH) (inch)		24-16/32*21-2/64*27-13/16
	(mm)	622*534*706
Packing(WxDxH) (inch)		28-9/32*27-23/64*30-11/32
	(mm)	715*695*765
Net/Gross weight (lbs.)		97/115
	(kg)	43.9/52.2
OUTDOOR UNIT DATA		
Compressor		
Type		SKDC051N1ULB
Model		SCROLL
Brand		GMCC
Capacity (Btu/h)		14200
Input (W)		3300
Rated current (RLA) (A)		14.6
Refrigerant oil/oil charge (ml)		ESTER OIL VG46 1240
Throttle		
Outdoor fan motor		
Model		DQ-DRN-310-200-8-B(A)
Qty		1
Input (W)		200.00
RLA (A)		0.92
Air flow & Noise level		
Outdoor air flow (Max.) (CFM)		2950
Outdoor noise level [dB(A)]		60.0
Outdoor unit		
Dimension (W×D×H) (inch)		29-9/64×29-9/64×32-7/8
	(mm)	740×740×835
Packing (W×D×H) (inch)		30-5/16×30-5/16×34-1/16
	(mm)	770×770×865
Net/ Gross weight (lbs.)		182/193
	(kg)	82.5/87.5

Indoor unit dimension

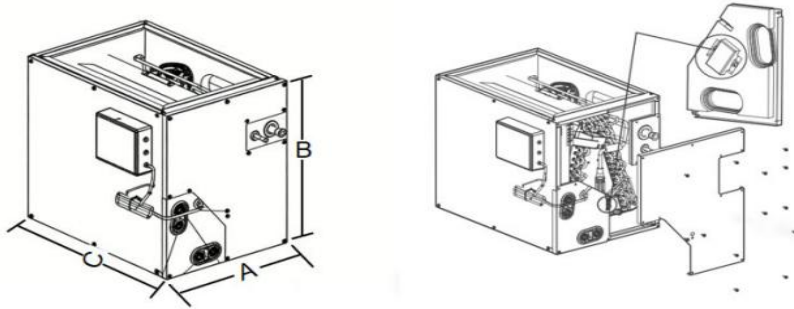

Dimensions		Model	AC32-1824B-15		AC32-3036B-15		AC32-3036C-15	
			inch	mm	inch	mm	inch	mm
A	Model Width		17-63/64	457	23-37/64	599	23-37/64	599
B	Model Height		17-33/64	445	17-33/64	445	21-1/32	534
C	Model Deep		21-1/32	534	21-1/32	534	21-1/32	534
Dimensions		Model	AC32-4860C-15		AC32-4860D-15			
			inch	mm	inch	mm		
A	Model Width		27-51/64	706	24-16/32	706		
B	Model Height		21-1/32	534	27-13/16	622		
C	Model Deep		21-1/32	534	21-1/32	534		

Outdoor unit dimension

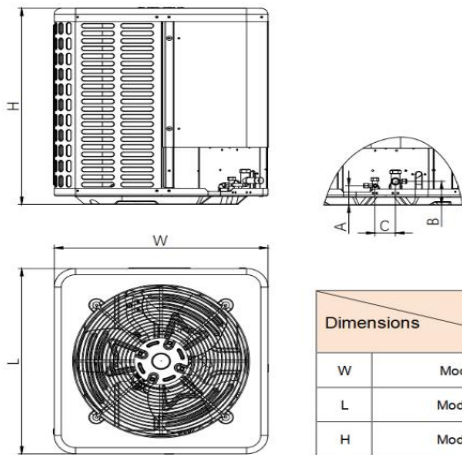

Dimensions		Model	18K/24K		30K/36K		42K/48K/60K	
			inch	mm	inch	mm	inch	mm
W	Model width		23-5/8	600	29-9/64	740	29-9/64	740
L	Model length		23-5/8	600	29-9/64	740	29-9/64	740
H	Model height		25	635	25	635	32-7/8	835
A	Liquid side valve height		2-31/64	63	2-31/64	63	2-31/64	63
B	Distance between two valves		3-1/32	77	3-1/32	77	3-1/32	77
C	Gas side valve height		2-9/32	58	2-9/32	58	2-9/32	58