

# ComfortStar<sup>®</sup>

Air Conditioning & Heating Products

## Service Manual

**BAR17-18-15(40G)**  
**BAR17-24-15(40H)**  
**BAR17-30-15(40J)**  
**BAR17-36-15(40K)**

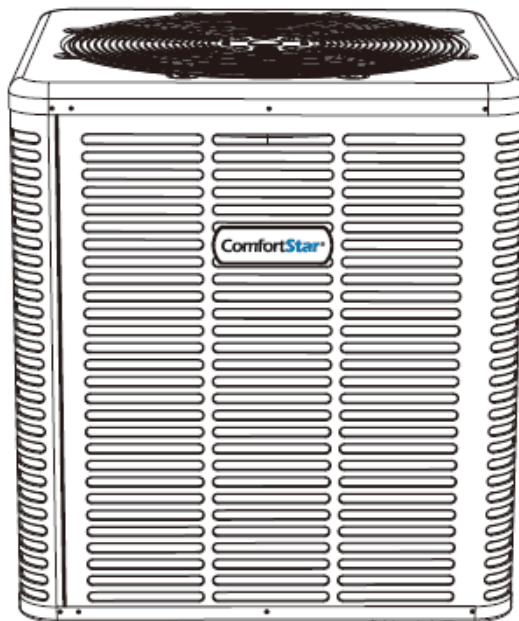

RECOGNIZE THIS SYMBOL AS A SAFETY PRECAUTION

### ATTENTION INSTALLING PERSONNEL

Prior to installation, thoroughly familiarize yourself with this Installation Manual. Observe all safety warnings.

During installation or repair, caution is to be observed

It is your responsibility to install the product safely and to educate the customer on its safe use

Eair LLC

12201 N.W. 107<sup>th</sup> Avenue, Medley, FL 33178

[www.comfortstarusa.com](http://www.comfortstarusa.com)



# Part 1

## General Information

1 Product lineup .....2

2 Specifications ..... 3

**1 Product lineup**

Model	Cooling Capacity(Btu/h)	Appearance
BAR17-18-15	18000	
BAR17-24-15	24000	
BAR17-30-15	30000	
BAR17-36-15	35000	
BAR10-42-15	42000	
BAR10-48-15	46000	
BAR10-60-15	54000	

## 2 Specifications

Power supply	Rated Voltage	V, Ph, Hz	208/230V, 1Ph, 60Hz						
Cooling	capacity	Btu/h	18000	24000	30000	35000	42000	46000	54000
	Input	W	1358	1871	2144	2503	3070	3543	3927
Outdoor Minimum Circuit Ampacity		A	15.0	20.0	20.0	25.0	25.0	30.0	40.0
Outdoor Max.Fuse		A	20.0	25.0	25.0	30.0	35.0	40.0	50.0
Outdoor Air Flow		CFM	2000	2000	2650	2650	2950	2950	2950
Outdoor Noise Level		dB(A)	58.0	58.0	59.0	59.0	60.0	60.0	60.0
Connecting Wiring		AWG	24V: AWG 14*3 Shielded	24V: AWG 12*3 Shielded	24V: AWG 10*3 Shielded	24V: AWG 8*3 Shielded			
Communication Type			24V						
Throttle type			Capillary						
Outdoor Unit	Unpacking(W*D*H)	inch	23-5/8×23-5/8×25		29-9/64×29-9/64×25		29-9/64×29-9/64×32-7/8		
	Packing (W*D*H)	inch	25-63/64×25-63/64×26-3/16		30-5/16×30-5/16×26-3/16		30-5/16×30-5/16×34-1/16		
	Net/Gross weight	lbs	117/123	119/126	139/148	145/154	157/168	176/187	182/193
Refrigeration	Type/Charge	oz	R32/46	R32/53	R32/76	R32/79	R32/92	R32/92	R32/92
	Outdoor Additional Charge	oz/ft	0.52	0.52	0.52	0.52	0.52	0.52	0.52
	N.A.Design Pressure	PSI	174/609	174/609	174/609	174/609	0.29	174/609	174/609
Refrigerant pipe	Liquid /Vapor Valve Size	inch	(3/8) / (3/4)	(3/8) / (3/4)	(3/8) / (3/4)	(3/8) / (3/4)	(3/8) / (3/4)	(3/8) / (3/4)	(3/8) / (3/4)
	Max. refrigerant pipe length	ft	98	131	131	131	164	213	213
	Max.Height Difference	ft	66	82	82	82	82	98	98
Outdoor unit	Cooling		23-125	23-125	23-125	23-125	23-125	23-125	23-125
	Heating		/	/	/	/	/	/	/
SERVICE CODE			40G	40H	40J	40K	40P	40L	40M

## Part 2

# Component Layout and Refrigerant Circuit

1 Layout Functional Components .....	5
2 Piping diagrams .....	6

### 1 Layout Functional Components

BAR17-18-15, BAR17-24-15, BAR17-30-15, BAR17-36-15,

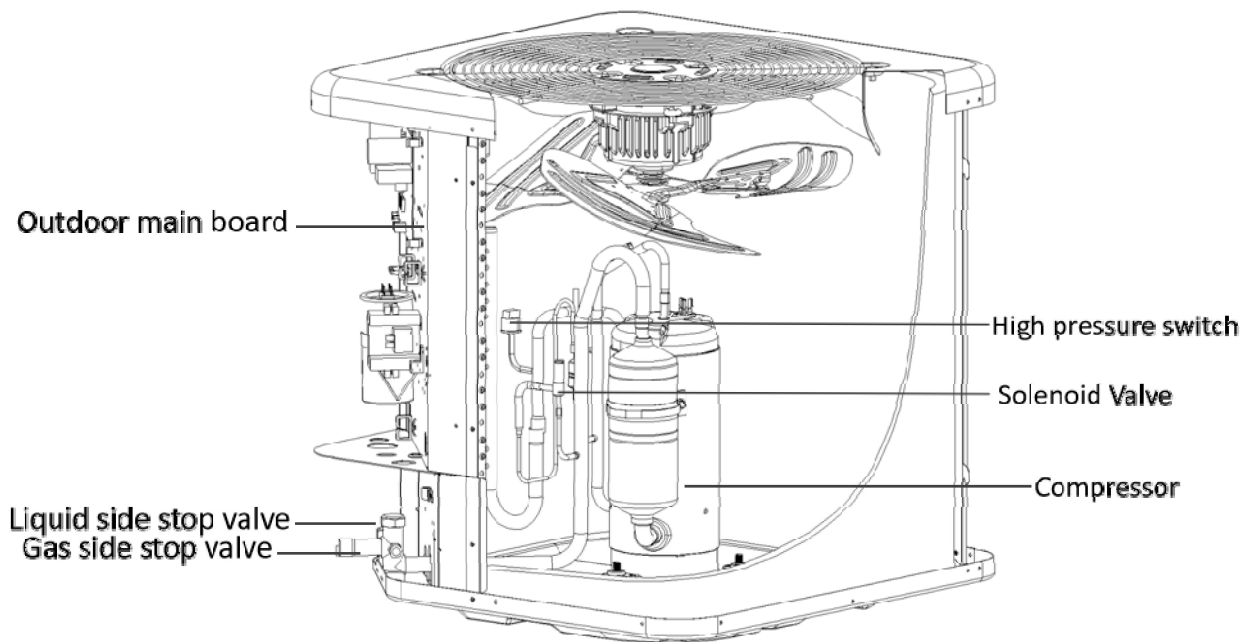

BAR10-42-15, BAR10-48-15, BAR10-60-15,

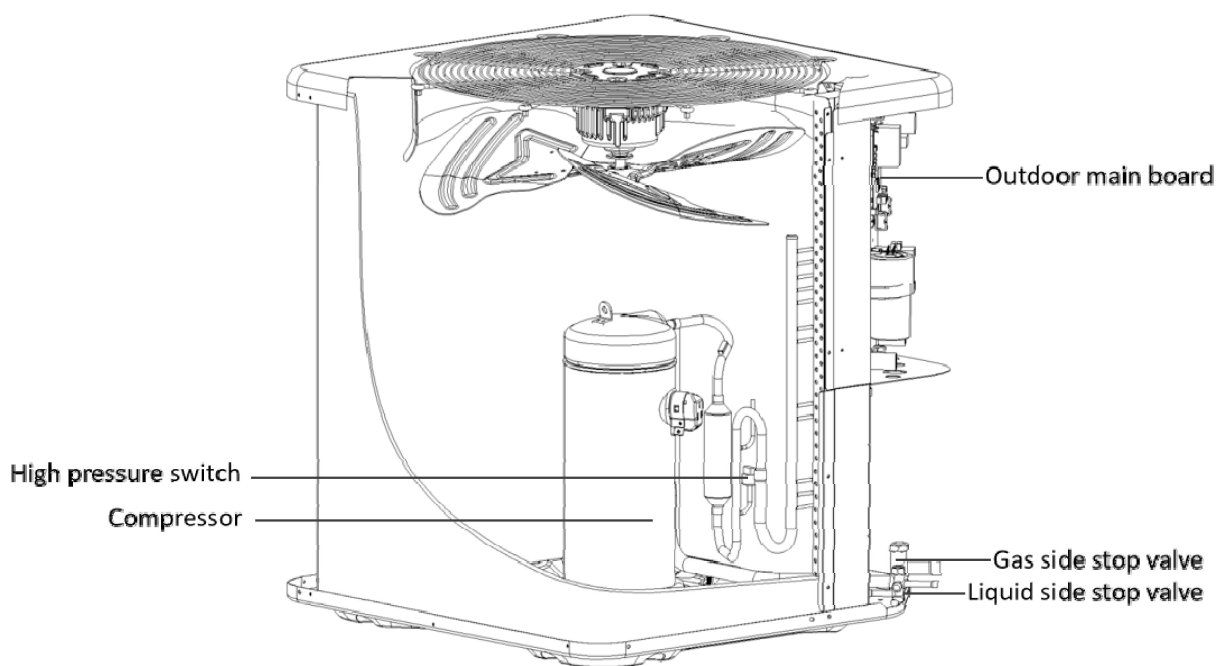

## 2 Piping diagrams

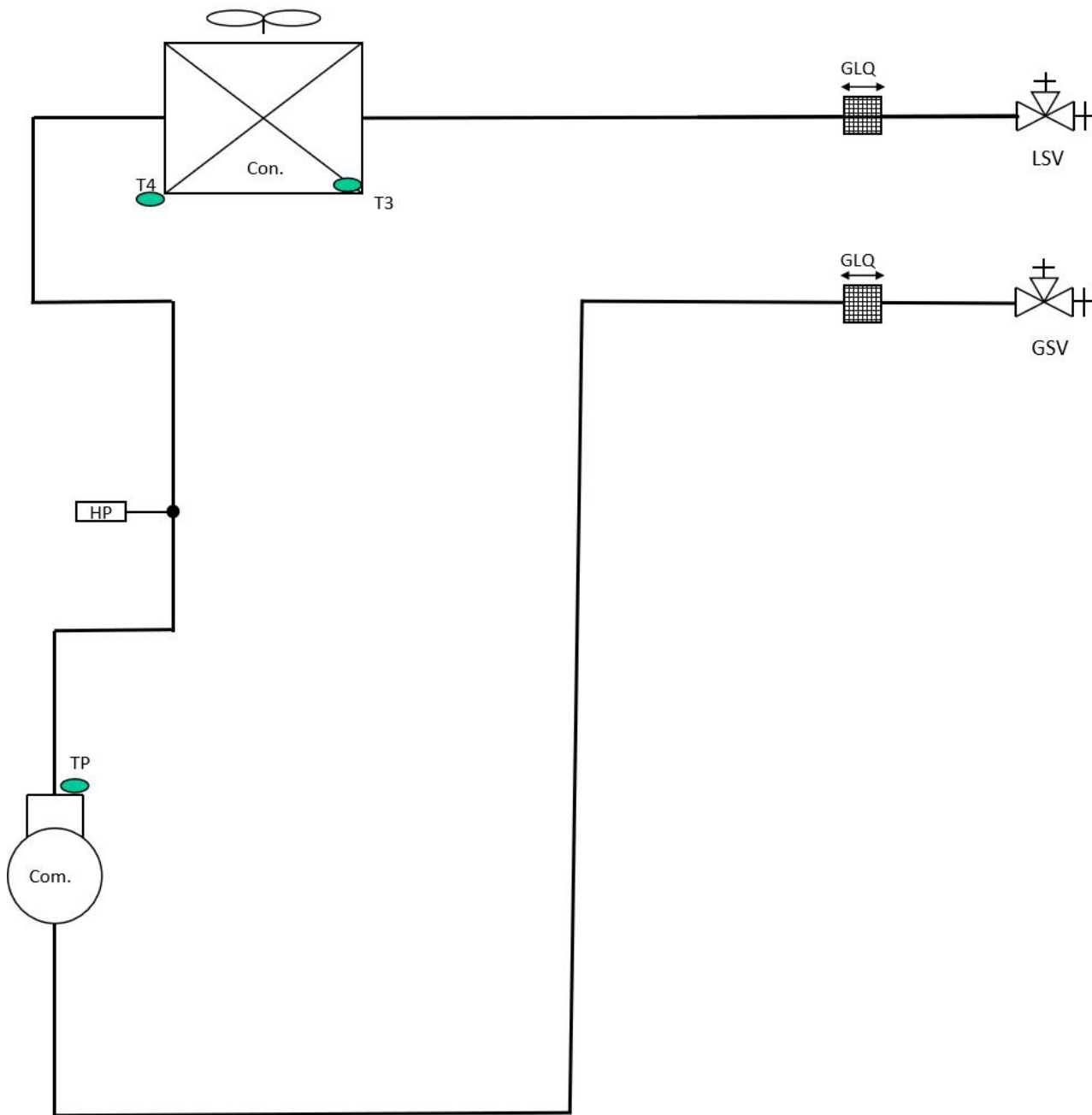

NO.	Component(Outdoor unit)	NO.	Component(Outdoor unit)
Com.	Compressor	LSV	Liquid Stop Valve
TP	Exhaust temperature sensor	GSV	Gas Stop Valve
HP	High pressure switch		
T4	Ambient temperature sensor		
T3	Condenser coil temperature sensor		
Con.	Condenser		
RCP	Refrigerant cooling pipe		
GLQ	Filter		

# Part 3

## Wiring Diagram

1 Electric wiring diagram .....	8
2 PCB .....	9
3 Low voltage wiring diagram .....	11

### 1 Electric wiring diagram

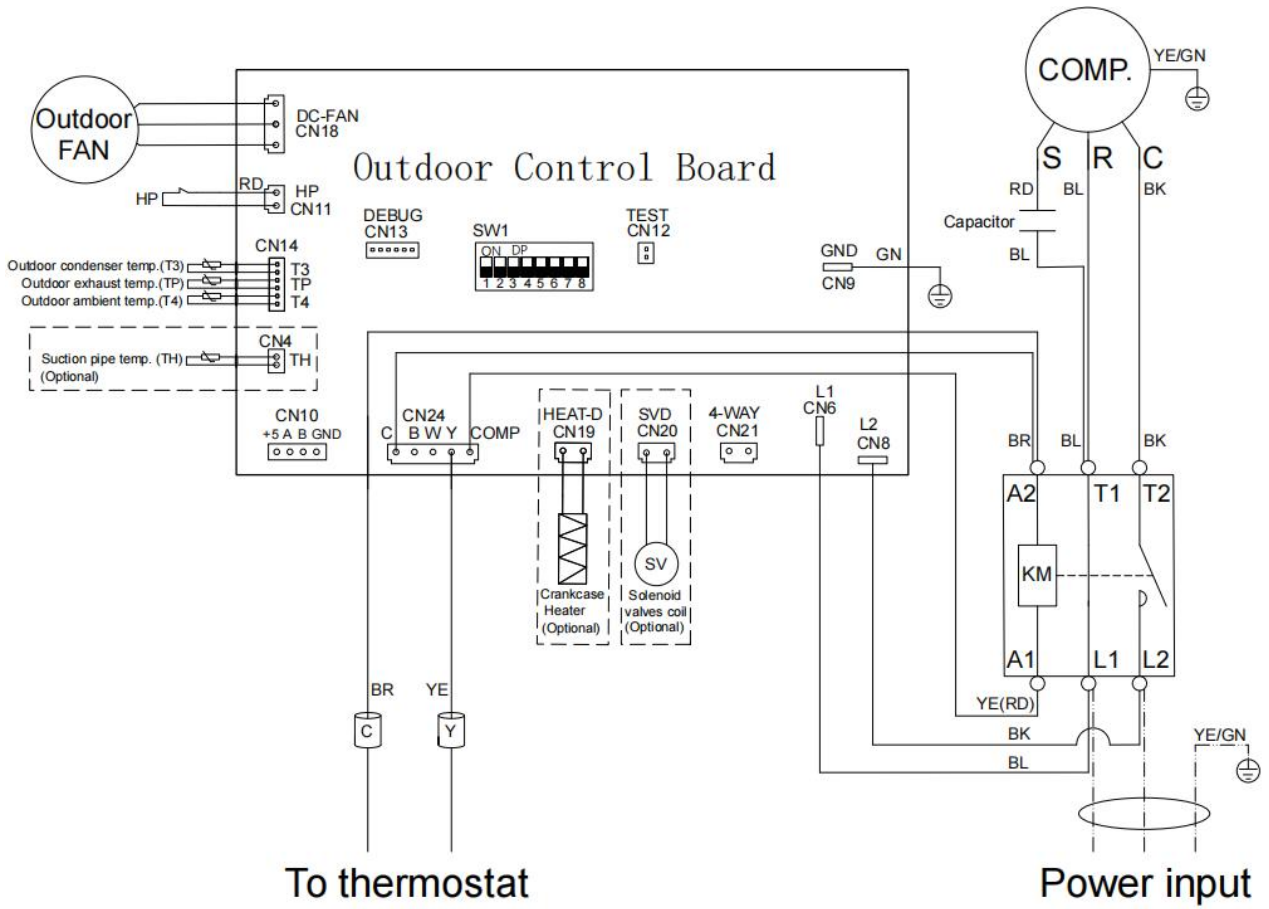

Note: 18k 24k 30k 36k models should connect Solenoid valves coil

2 PCB

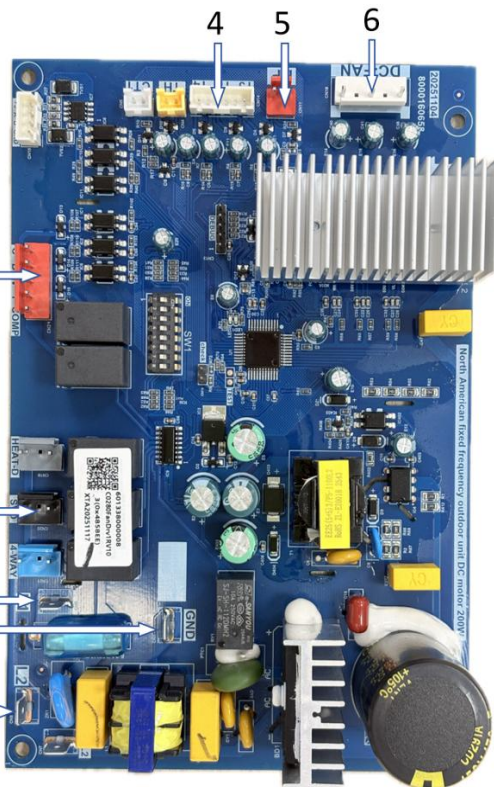

The image shows a blue printed circuit board (PCB) for an outdoor unit. It features a large silver heat sink in the center, a black capacitor at the bottom right, and various electronic components. Eight numbered callouts point to specific terminals: 1 (L1), 2 (N2), 3 (GND), 4 (T3 T4 TP sensor port), 5 (High pressure protection switch port), 6 (DC motor port), 7 (C B W Y COMP port(24V)), and 8 (Solenoid valve port).

No.	Functional description
1	Power supply input L(L1)
2	Power supply input N(L2)
3	Ground wire
4	T3 T4 TP sensor port
5	High pressure protection switch port
6	DC motor port
7	C B W Y COMP port(24V)
8	Solenoid valve port

**18/24/30/36K Outdoor Main Control Board**

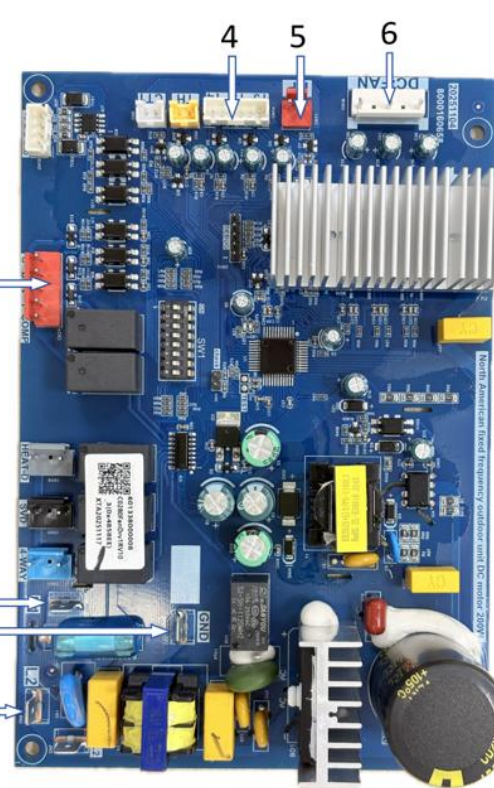

The image shows a blue printed circuit board (PCB) for an outdoor unit, similar to the one above but with a different terminal configuration. Seven numbered callouts point to specific terminals: 1 (L1), 2 (N2), 3 (GND), 4 (T3 T4 TP sensor port), 5 (High pressure protection switch port), 6 (DC motor port), and 7 (C B W Y COMP port(24V)).

No.	Functional description
1	Power supply input L(L1)
2	Power supply input N(L2)
3	Ground wire
4	T3 T4 TP sensor port
5	High pressure protection switch port
6	DC motor port
7	C B W Y COMP port(24V)

**42/48/60K Outdoor Main Control Board**

Definition of SW1

Wire Color Code	DIP switch status Indicate		Outdoor Display Board SW1 DIP switch selection				Outdoor Display Board SW1 DIP switch selection		
			SW1.1	SW1.2	SW1.4		SW1.7	SW1.8	
RD RED OR ORANGE	ON <input type="checkbox"/>	This Indicate OFF ( The DIP switch is dialed to the digital side)	OFF	24V Control (Default)			SW1.5	OFF	Reserved (Default)
BL BLUE GN GREEN	OFF <input checked="" type="checkbox"/>		ON	RS485 Comm. Mode				ON	Manual Defrosting
BR BROWN GY GRAY	ON <input checked="" type="checkbox"/>	This Indicate ON ( The DIP switch is dialed to the non-digital side)	OFF	Heating and cooling			SW1.6	OFF	Auto Defrosting (Default)
BK BLACK YE YELLOW			ON	Single-cooled (Default)				ON	Periodically Defrosting
WH WHITE PR PURPLE	OFF <input type="checkbox"/>		OFF	OFF	Model	18K	SW1.7	OFF	Defrost interval 60 minutes (Default)
			OFF	ON		24K 30K 36K 42K		ON	Defrost interval 30 minutes
			ON	OFF		Reserved		OFF	General mode (Default)
			ON	ON		48K 60K		ON	High vertical mode

### 3 Low voltage wiring diagram

The following wiring diagram are suitable for the Indoor Unit and Outdoor Unit with 24V thermostat.

#### Cooling-Only Model

Wiring for 1H and 1C thermostat (no heat pump system model)

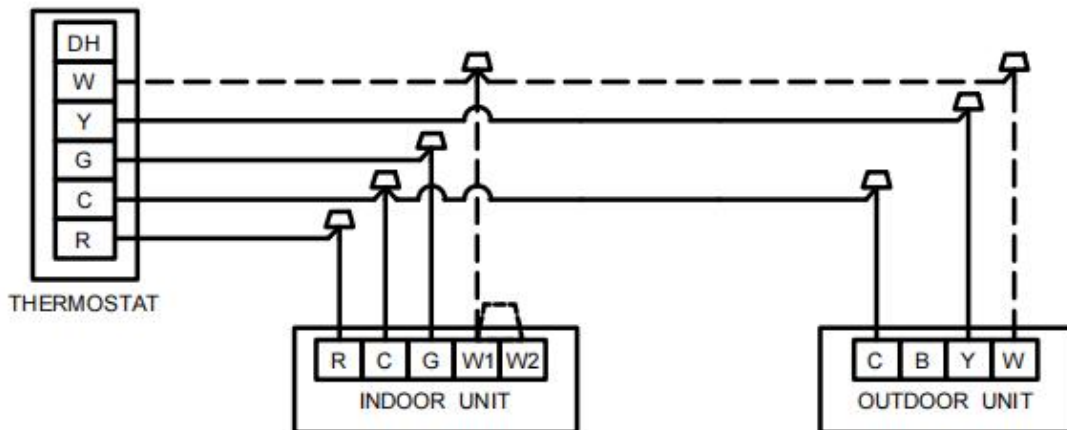

Wiring for 1H and 1C thermostat (no heat pump system model)

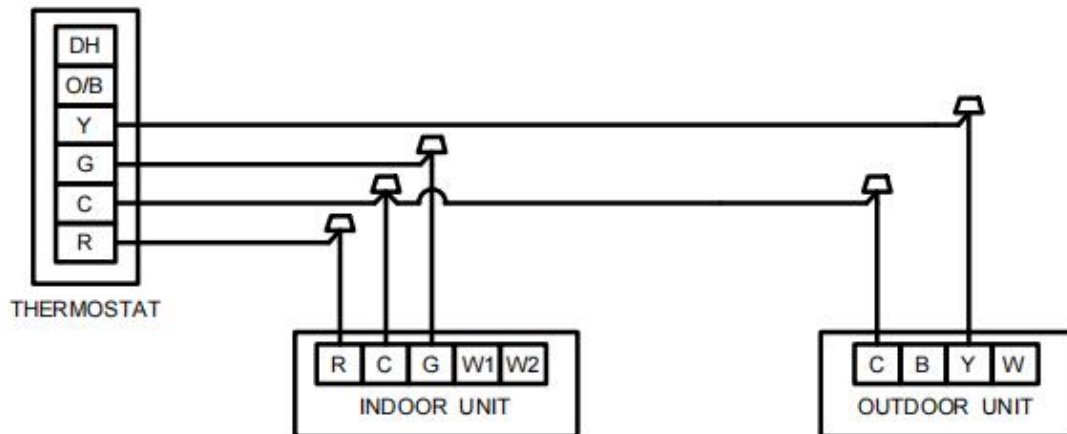

Wiring for 2H and 1C thermostat (no heat pump system model)

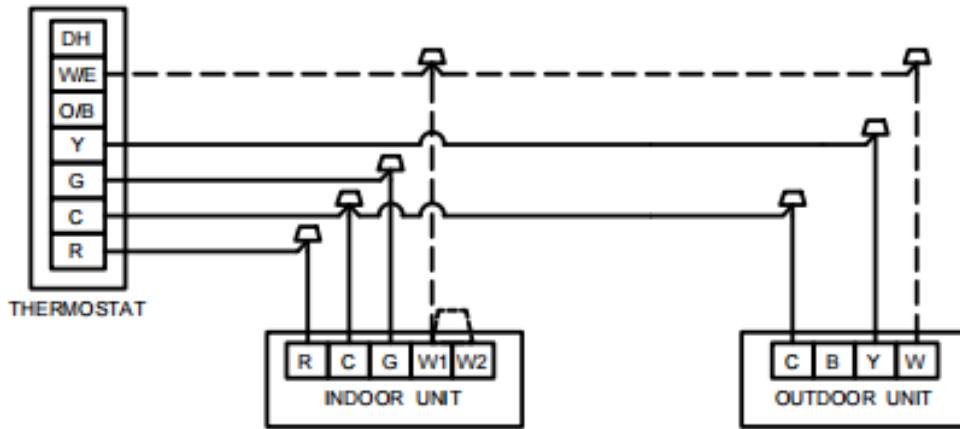

Wiring for 2H and 2C thermostat (no heat pump system model)

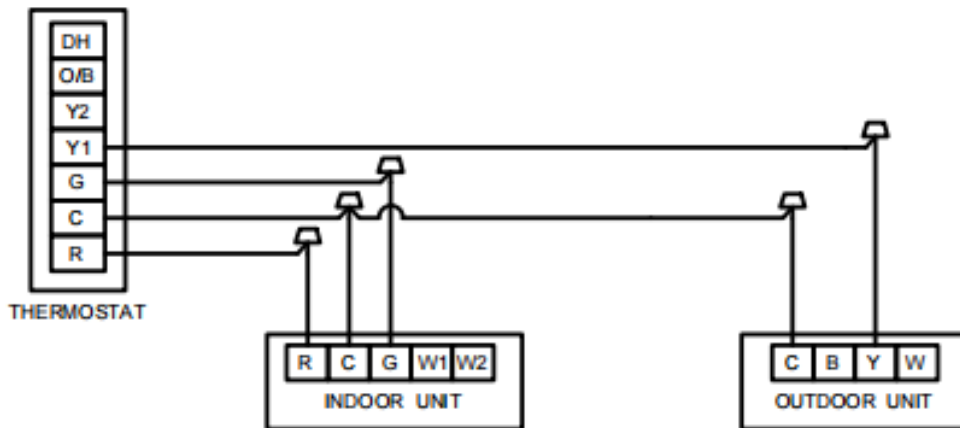

Wiring for 3H and 1C thermostat (no heat pump system model)

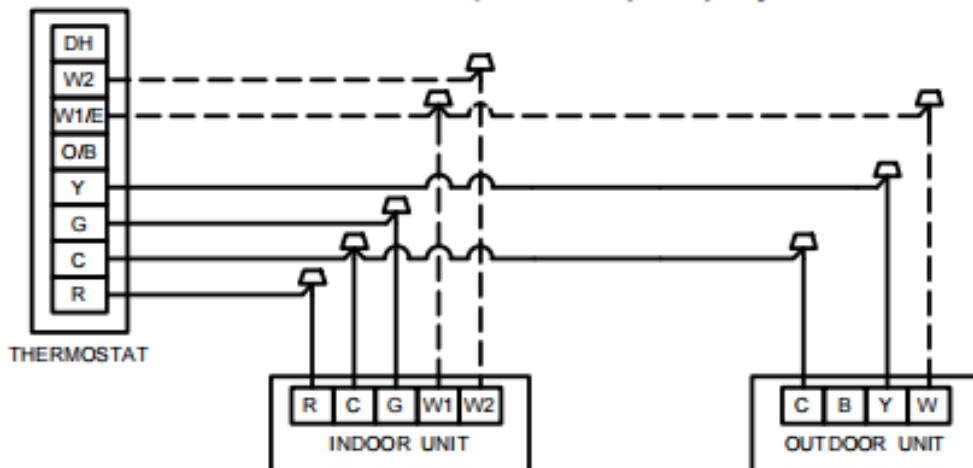

Wiring for 3H and 2C thermostat (no heat pump system model)

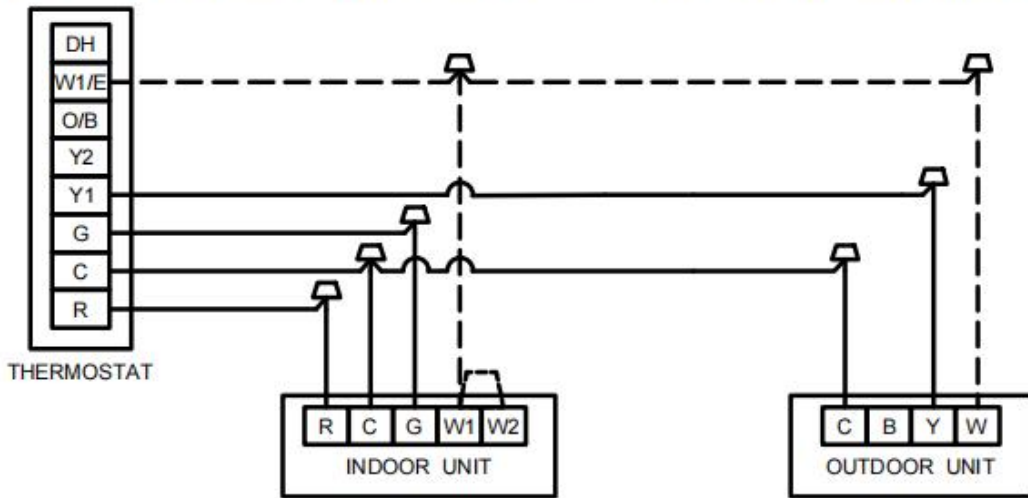

Wiring for 4H and 2C thermostat (no heat pump system model)

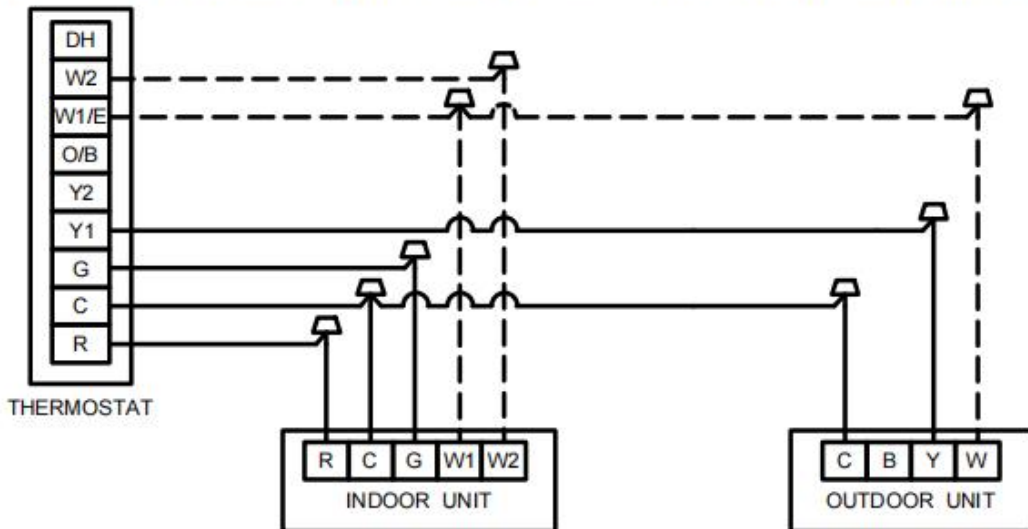

Control Logic:

Indoor unit connector

Connector	Purpose
R	24V Power Connection
C	Common
G	Fan Control
W1	Stage 1 Electric Heating
W2	Stage 2 Electric Heating

Outdoor unit connector

Connector	Purpose
C	Common
Y	Cooling

**Note:**

- 1) DH wiring is optional and requires a thermostat with a humidistat. DH functions as Passive Dehumidification and will downstage the indoor fan to first stage. System will operate according to normal sequence of operations if DH wiring is absent.
- 2) Dashed lines in the above thermostat wiring diagrams refer to optional wiring (wiring for Passive Dehumidification Function and/OR Electric Heat). For thermostat wiring please refer to the Owner's Manual of the thermostat.

## Part 4

# Diagnosis and Troubleshooting

- 1 Error code table ..... 16
- 2 Troubleshooting ..... 17
  - 2.1 Safety Precautions ..... 17
  - 2.2 ATL Troubleshooting ..... 20
  - 2.3 High Pressure Alert ..... 21
  - 2.4 TP Exhaust Over-temperature Protection Troubleshooting ..... 22
  - 2.5 T3/T4/TP Troubleshooting ..... 23
- 3. Temperature Sensor Resistance Characteristics ..... 24

### 1 Error code table

	LED Display	System Status
Operating Mode	Green Light: Flash 1 time per Second Red Light: Off	Standby
	Green Light: Steadily On Red Light: Off	Cooling Heating
System Alert	Green Light: Flashes 1 Time Red Light: Off	Low Pressure Alert(Reserved)
	Green Light: Flashes 2 Times Red Light: Off	High Pressure Alert
	Green Light: Flashes 3 Times Red Light: Off	Tp Exhaust Over-temperature Protection
	Green Light: Flashes 4 Times Red Light: Off	TH Anti-freeze Protection Fault(Reserved)
	Green Light: Flashes 5 Times Red Light: Off	T4 Ambient Temperature Protection
	Green Light: Flashes 6 Times Red Light: Off	T3 Over-temperature Protection
	Green Light: Off Red Light: Flashes 1 Time	T3 Sensor Error
	Green Light: Off Red Light: Flashes 2 Times	T4 Sensor Error
	Green Light: Off Red Light: Flashes 3 Times	Tp Sensor Error
	Green Light: Off Red Light: Flashes 4 Times	TH Sensor Error(Reserved)
	Green Light: Flashes 1 Time Red Light: Flashes 1 Time	DC fan failure
	System Lockout	Green Light: Off Red Light: Flashes 5 Times
Green Light: Off Red Light: Flashes 6 Times		3 Exhaust Over-temperature Faults within 60 Mins
Green Light: Off Red Light: Flashes 7 Times		8 TH Anti-freeze Faults within 200 Mins(Reserved)

**Note:** When a fault code is indicated by "flashing N times", it means the LED will perform N short cycles of 0.5s ON / 0.5s OFF, followed by a 4-second long OFF period. For example, a fault code of "flashing 4 times" means the LED will flash 4 times (0.5s ON / 0.5s OFF per cycle), then stay off for 4 seconds. The timing diagram is shown below.

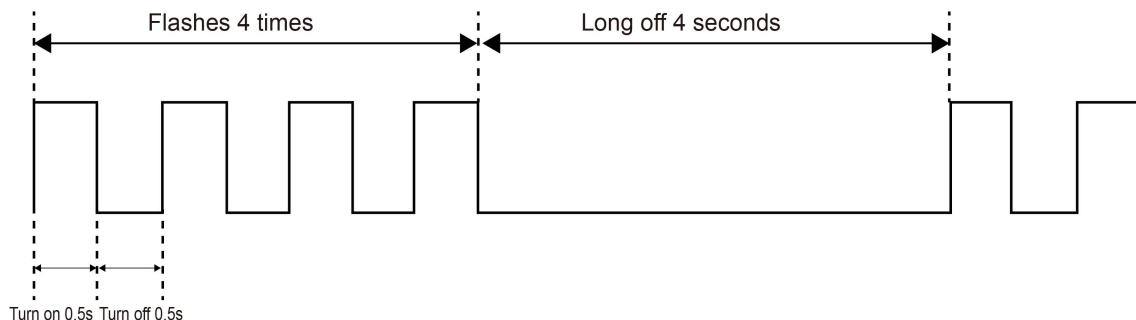

## 2 Troubleshooting

### 2.1 Safety Precautions

The following precautions here are quite important, so be sure to follow them carefully. Read these instructions carefully before installation. Keep this manual in a handy for future preference.

Failure to adhere to all precautionary measures listed in this section may result in personal injury, damage to the unit or to property, or in extreme cases, death.



#### WARNING

- Indicates a potentially hazardous situation which if not avoided, could result in death or serious injury.



#### CAUTION

- Indicates a potentially hazardous situation which if not avoided, may result in minor or moderate injury.
- It is also used to alert against unsafe practices.

#### 2.1.1 In case of Accidents or Emergency



#### WARNING

- If a gas leak is suspected, immediately turn off the gas and ventilate the area if a gas leak is suspected before turning the unit on.
- If strange sounds or smoke is detected from the unit, turn the breaker off and disconnect the power supply cable.
- If the unit comes into contact with liquid, contact an authorized service center.
- If liquid from the batteries makes contact with skin or clothing, immediately rinse or wash the area well with clean water.
- Do not insert hands or other objects into the air inlet or outlet while the unit is plugged in.
- Do not operate the unit with wet hands.



#### CAUTION

- Clean and ventilate the unit at regular intervals when operating it near a stove or near similar devices.
- Do not use the unit during severe weather conditions. If possible, remove the product from the window before such occurrences.

### 2.1.2 Information servicing(For flammable materials)



#### WARNING

---

- Use this unit only on a dedicated circuit.
- Damage to the installation area could cause the unit
- to fall, potentially resulting in personal injury, property damage, or product failure.
- Only qualified personnel should disassemble, install, remove, or repair the unit.
- Only a qualified electrician should perform electrical work. For more information, contact your dealer, seller, or an authorized service center.



#### CAUTION

---

- While unpacking be careful of sharp edges around the unit as well as the edges of the fins on the condenser and evaporator.

### 2.1.3 Operation and Maintenance



#### WARNING

---

- Do not use defective or under-rated circuit breakers.
- Ensure the unit is properly grounded and that a dedicated circuit and breaker are installed.
- Do not modify or extend the power cable. Ensure the power cable is secure and not damaged during operation.
- Do not unplug the power supply plug during operation.
- Do not store or use flammable materials near the unit.
- Do not open the inlet grill of the unit during operation.
- Do not touch the electrostatic filter if the unit is equipped with one.
- Do not block the inlet or outlet of air flow to the unit.
- Do not use harsh detergents, solvents, or similar items to clean the unit. Use a soft cloth for cleaning.
- Do not touch the metal parts of the unit when removing the air filter as they are very sharp.
- Do not step on or place anything on the unit or outdoor units.
- Do not drink water drained from the unit.
- Avoid direct skin contact with water drained from the unit.

- Use a firm stool or step ladder according to manufacturer procedures when cleaning or maintaining the unit.

**CAUTION**

---

- Do not install or operate the unit for an extended period of time in areas of high humidity or in an environment directly exposing it to sea wind or salt spray.
- Do not install the unit on a defective or damaged installation stand, or in an unsecured location.
- Ensure the unit is installed at a level position
- Do not install the unit where noise or air discharge
- Created by the outdoor unit will negatively impact the environment or nearby residences.
- Do not expose skin directly to the air discharged by the unit for prolonged periods of time.
- Ensure the unit operates in areas waterOr other liquids.
- Ensure the drain hose is installed correctly to ensure proper water drainage.
- When lifting or transporting the unit, it is recommended that two or more people are used for this task.
- When the unit is not to be used for an extended time, disconnect the power supply or turn off the breaker.

## 2.2 ATL Troubleshooting

- ATL indicates ambient temperature out of bounds protection.
- The unit stops running and will not start operating until the ambient temperature returns to the allowable temperature range, error code is displayed on the communication board.
- The allowable ambient temperature range is 5~ 131 °F (-15~55°C).

### 2.3 High Pressure Alert

- Green light flashes 2 times with red light off indicates High Pressure Alert.

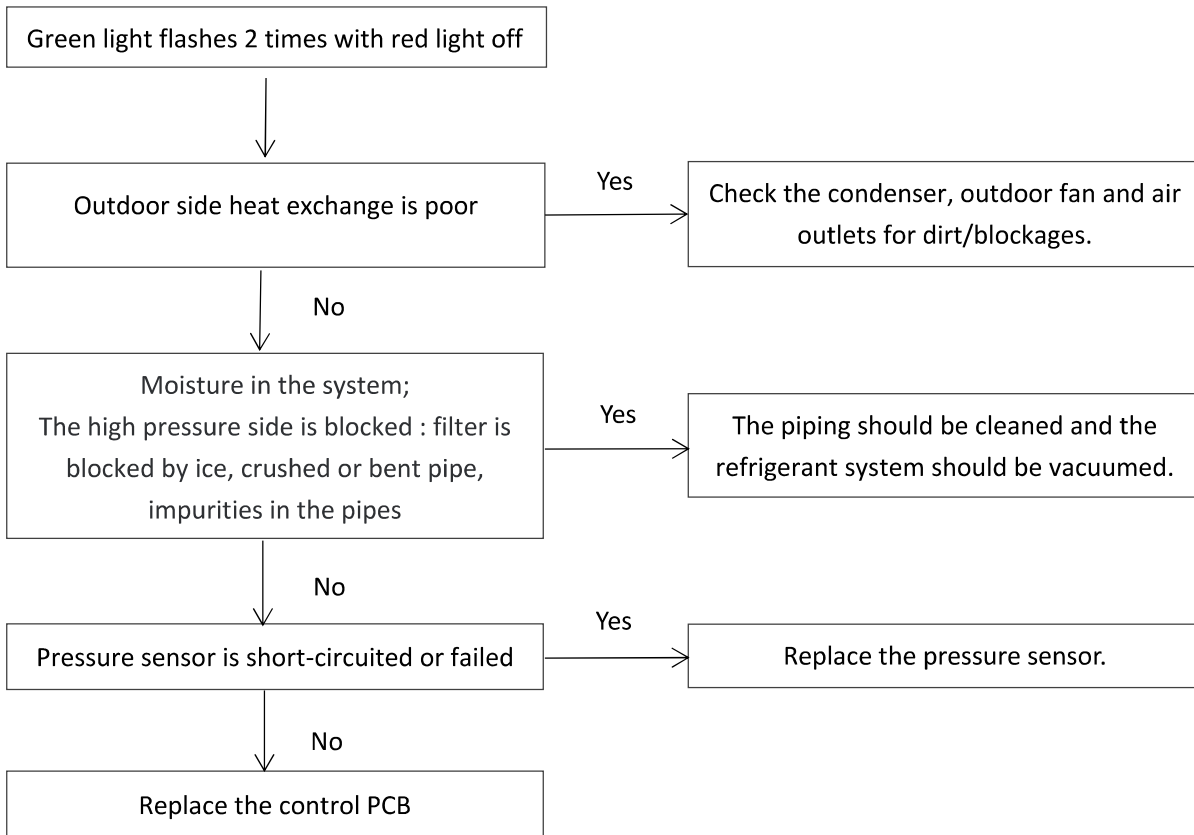

**2.4 TP Exhaust Over-temperature Protection Troubleshooting**

- Green light flashes 3 times with red light off indicates discharge temperature protection.
- The unit stops running and error code is displayed on the communication board.

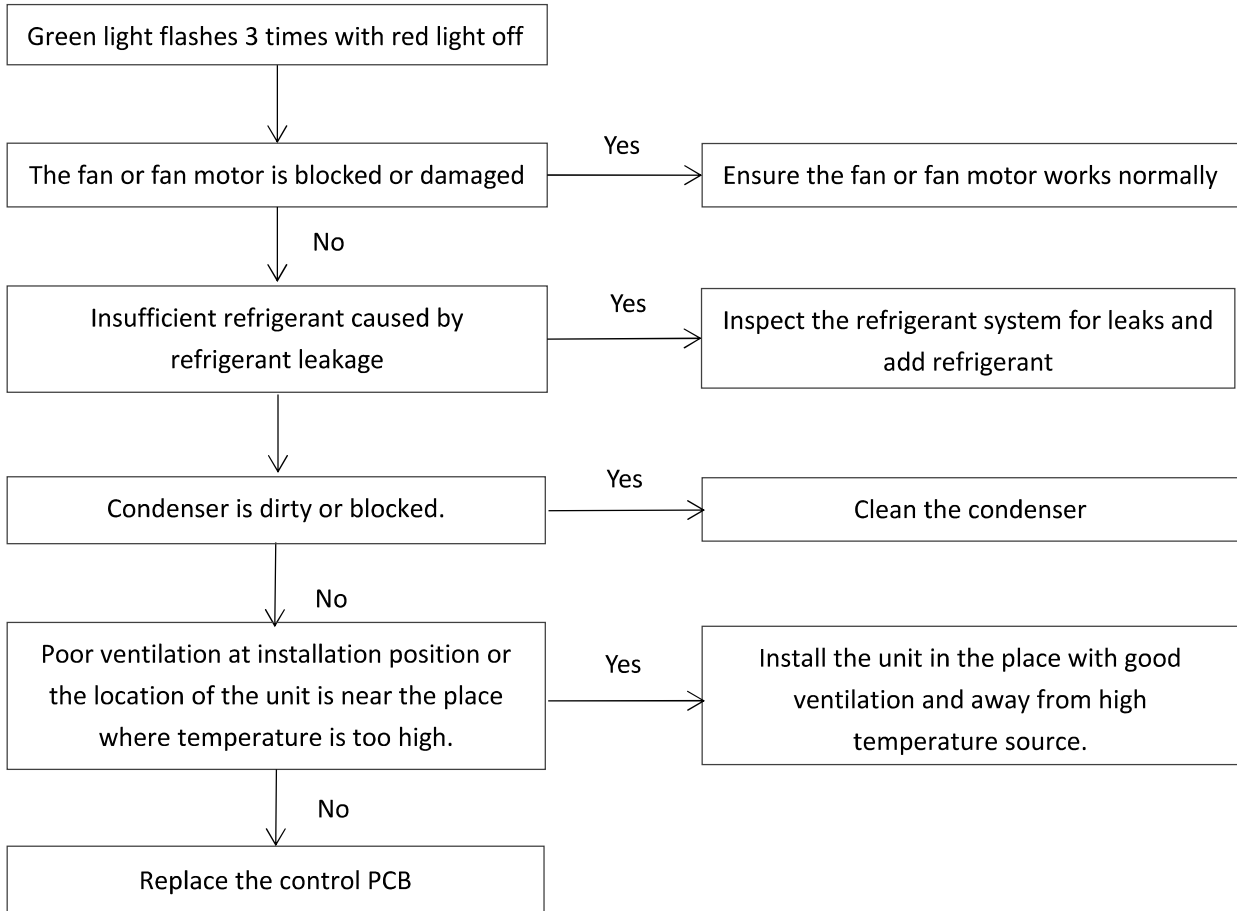

**2.5 T3/T4/TP Troubleshooting**

- Green light flashes 5 times with red light off indicates Ambient Temperature Protection.
- Green light flashes 5 times with red light off indicates T3 Over-temperature Protection.
- Green light off with red light flashes 1 times indicates T3 Sensor Error.
- Green light off with red light flashes 2 times indicates T4 Sensor Error.
- Green light off with red light flashes 3 times indicates TP Sensor Error.
- Green light off with red light flashes 6 times indicates Exhaust Over-temperature Faults within 60 mins.

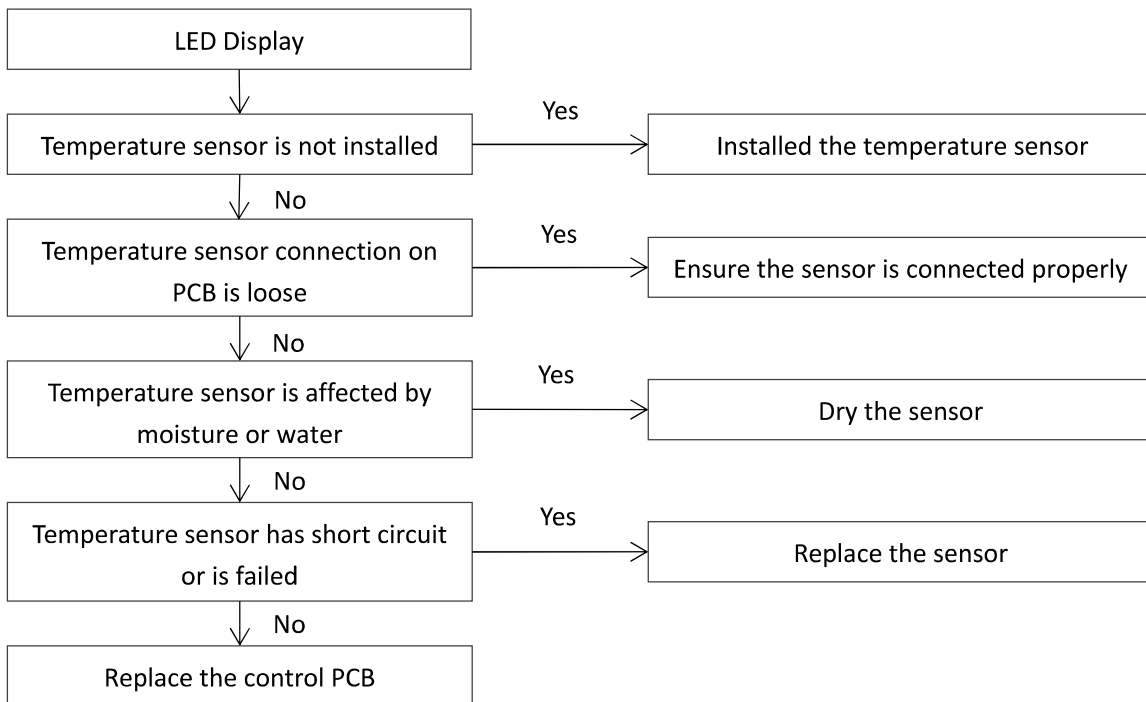

Note:

- 1) Measure sensor resistance. If the resistance is too low, the sensor has short-circuited. If the resistance is not consistent with the sensor’s resistance characteristics table, the sensor has failed.

### 3. Temperature Sensor Resistance Characteristics

Outdoor ambient temperature sensor(T4) and condenser coil temperature sensor(T3) resistance characteristics.

Temperature (°C)	Temperature (°F)	Resistance (kQ)	Temperature (°C)	Temperature (°F)	Resistance (kQ)
-25	-13	144.266	15	59	16.079
-24	-11	135.601	16	61	15.313
-23	-9	127.507	17	63	14.588
-22	-8	119.941	18	64	13.902
-21	-6	112.867	19	66	13.251
-20	-4	106.732	20	68	12.635
-19	-2	100.552	21	70	12.05
-18	0	94.769	22	72	11.496
-17	1	89.353	23	73	10.971
-16	3	84.278	24	75	10.473
-15	5	79.521	25	77	10
-14	7	75.059	26	79	9.551
-13	9	70.873	27	81	9.125
-12	10	66.943	28	82	8.721
-11	12	63.252	29	84	8.337
-10	14	59.784	30	86	7.972
-9	16	56.524	31	88	7.625
-8	18	53.458	32	90	7.296
-7	19	50.575	33	91	6.982
-6	21	47.862	34	93	6.684
-5	23	45.308	35	95	6.401
-4	25	42.903	36	97	6.131
-3	27	40.638	37	99	5.874
-2	28	38.504	38	100	5.63
-1	30	36.492	39	102	5.397
0	32	34.596	40	104	5.175
1	34	32.807	41	106	4.964
2	36	31.12	42	108	4.763
3	37	29.528	43	109	4.571
4	39	28.026	44	111	4.387
5	41	26.608	45	113	4.213
6	43	25.268	46	115	4.046
7	45	24.003	47	117	3.887
8	46	22.808	48	118	3.735
9	48	21.678	49	120	3.59
10	50	20.61	50	122	3.451
11	52	19.601	51	124	3.318
12	54	18.646	52	126	3.191
13	55	17.743	53	127	3.069
14	57	16.888	54	129	2.952

Temperature(°C)	Temperature(°F)	Resistance(kQ)	Temperature(°C)	Temperature(°F)	Resistance(kQ)
55	131	2.841	95	171	0.708
56	133	2.734	96	173	0.686
57	135	2.632	97	175	0.666
58	136	2.534	98	176	0.646
59	138	2.44	99	178	0.627
60	140	2.35	100	180	0.609
61	142	2.264	101	182	0.591
62	144	2.181	102	184	0.574
63	145	2.102	103	185	0.558
64	147	2.026	104	187	0.542
65	149	1.953	105	189	0.527
66	151	1.883			
67	153	1.816			
68	154	1.752			
69	156	1.69			
70	158	1.631			
71	160	1.574			
72	162	1.519			
73	163	1.466			
74	165	1.416			
75	167	1.367			
76	169	1.321			
77	171	1.276			
78	172	1.233			
79	174	1.191			
80	176	1.151			
81	178	1.113			
82	180	1.076			
83	181	1.041			
84	183	1.007			
85	185	0.974			
86	187	0.942			
87	189	0.912			
88	190	0.883			
89	192	0.855			
90	194	0.828			
91	196	0.802			
92	198	0.777			
93	199	0.753			
94	201	0.73			

Compressor exhaust temperature sensor (TP) resistance characteristics.

Temperature (°C)	Temperature (°F)	Resistance (kΩ)	Temperature (°C)	Temperature (°F)	Resistance (kΩ)
-20	-4	542.7	20	68	68.66
-19	-2	511.9	21	70	65.62
-18	0	483	22	72	62.73
-17	1	455.9	23	73	59.98
-16	3	430.5	24	75	57.37
-15	5	406.7	25	77	54.89
-14	7	384.3	26	79	52.53
-13	9	363.3	27	81	50.28
-12	10	343.6	28	82	48.14
-11	12	325.1	29	84	46.11
-10	14	307.7	30	86	44.17
-9	16	291.3	31	88	42.33
-8	18	275.9	32	90	40.57
-7	19	261.4	33	91	38.89
-6	21	247.8	34	93	37.3
-5	23	234.9	35	95	35.78
-4	25	222.8	36	97	34.32
-3	27	211.4	37	99	32.94
-2	28	200.7	38	100	31.62
-1	30	190.5	39	102	30.36
0	32	180.9	40	104	29.15
1	34	171.9	41	106	28
2	36	163.3	42	108	26.9
3	37	155.2	43	109	25.86
4	39	147.6	44	111	24.85
5	41	140.4	45	113	23.89
6	43	133.5	46	115	22.89
7	45	127.1	47	117	22.1
8	46	121	48	118	21.26
9	48	115.2	49	120	20.46
10	50	109.8	50	122	19.69
11	52	104.6	51	124	18.96
12	54	99.69	52	126	18.26
13	55	95.05	53	127	17.58
14	57	90.66	54	129	16.94
15	59	86.49	55	131	16.32
16	61	82.54	56	133	15.73
17	63	78.79	57	135	15.16
18	64	75.24	58	136	14.62
19	66	71.86	59	138	14.09

Temperature (°C)	Temperature (°F)	Resistance (kQ)	Temperature (°C)	Temperature (°F)	Resistance (kQ)
60	140	13.59	100	212	3.702
61	142	13.11	101	214	3.595
62	144	12.65	102	216	3.492
63	145	12.21	103	217	3.392
64	147	11.79	104	219	3.296
65	149	11.38	105	221	3.203
66	151	10.99	106	223	3.113
67	153	10.61	107	225	3.025
68	154	10.25	108	226	2.941
69	156	9.902	109	228	2.86
70	158	9.569	110	230	2.781
71	160	9.248	111	232	2.704
72	162	8.94	112	234	2.63
73	163	8.643	113	235	2.559
74	165	8.358	114	237	2.489
75	167	8.084	115	239	2.422
76	169	7.82	116	241	2.357
77	171	7.566	117	243	2.294
78	172	7.321	118	244	2.233
79	174	7.086	119	246	2.174
80	176	6.859	120	248	2.117
81	178	6.641	121	250	2.061
82	180	6.43	122	252	2.007
83	181	6.228	123	253	1.955
84	183	6.033	124	255	1.905
85	185	5.844	125	257	1.856
86	187	5.663	126	259	1.808
87	189	5.488	127	261	1.762
88	190	5.32	128	262	1.717
89	192	5.157	129	264	1.674
90	194	5	130	266	1.632
91	196	4.849			
92	198	4.703			
93	199	4.562			
94	201	4.426			
95	203	4.294			
96	205	4.167			
97	207	4.045			
98	208	3.927			
99	210	3.812			