

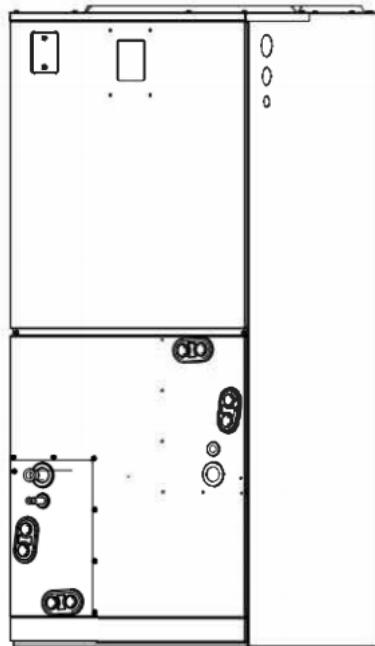

Service Manual

Indoor unit:

LUC17-18-15(442)	LUC17-24-15(443)
LUC17-30-15(444)	LUC17-36-15(445)
LUC17-42-15(446)	LUC17-48-15(447)
LUC17-60-15(448)	



RECOGNIZE THIS SYMBOL AS A SAFETY PRECAUTION

ATTENTION INSTALLING PERSONNEL

Prior to installation, thoroughly familiarize yourself with this Installation Manual. Observe all safety warnings.

During installation or repair, caution is to be observed

It is your responsibility to install the product safely and to educate the customer on its safe use

Eair LLC

12201 N.W. 107th Avenue, Medley, FL 33178



www.comfortstarusa.com

Part 1

General Information

1 Product lineup	2
2 Specifications	3
3 Dimensional drawings	4
4 Layout Functional Components	5

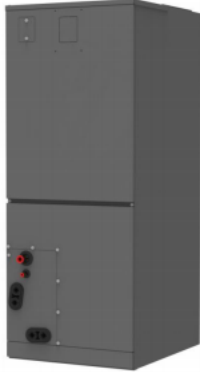
1 Product lineup

Model	Cooling Capacity (Btu/h)	Heating Capacity (Btu/h)	Appearance
LUC17-18-15	18000	17600	
LUC17-24-15	24000	24000	
LUC17-30-15	30000	30000	
LUC17-36-15	34200	34000	
LUC17-42-15	42000	42000	
LUC17-48-15	46000	46000	
LUC17-60-15	54000	53000	

2 Specifications

Model	Indoor unit		LUC17-18-15	LUC17-24-15	LUC17-30-15	LUC17-36-15	LUC17-42-15	LUC17-48-15	LUC17-60-15
Power Supply		V, Ph, Hz	208/230, 1, 60,						
Cooling	Capacity	Btu/h	18000	24000	30000	34200	42000	46000	54000
Heating	Capacity	Btu/h	17600	24000	30000	34000	42000	46000	53000
Air flow volume	H/L	CFM	650/420	650/420	950/520	950/520	1100/750	1690/750	1740/750
External Static Pressure		inch.w.g.	0.8	0.8	0.8	0.8	0.8	0.8	0.8
Noise level	H/L	dB(A)	38.5/34		40/36		53/46		
Unit Demension	W*D*H	mm	445×534×1143		534×534×1245		622×534×1346		
	W*D*H	inch	17-33/64×21-1/32×45		21-1/32×21-1/32×49-7/32		24-31/64×21-1/32×52-63/64		
Packing Demension	W*D*H	mm	530×675×1175		620×675×1275		708×675×1375		
	W*D*H	inch	20-55/64×26-37/64×46-17/64		24-13/32×26-37/64×50-13/64		27-7/8×26-37/64×54-9/64		
Net/Gross Weight		kg	51.5/57.5		62/68.5		75/83.5		
		lbs	114/127		137/151		165/184		
Setting Tem.	Cooling		60-90						
	Heating		32-86						
Service Code	indoor		442	443	444	445	446	447	448

3 Dimensional drawings

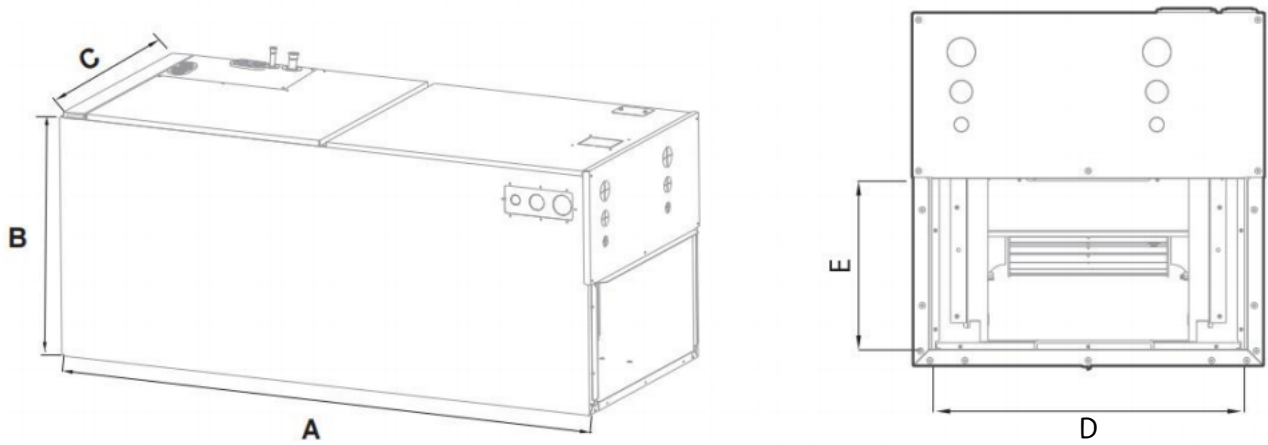

Dimensions		Model (Btu/h)	18/24K	30/36K	42/48/60K
A	mm		1145	1245	1346
	inch		45	49-7/32	52-63/64
B	mm		534	534	534
	inch		21-1/32	21-1/32	21-1/32
C	mm		445	534	622
	inch		17-33/64	21-1/32	24-31/64
D	mm		400	490	580
	inch		15-3/4	19-19/64	22-53/64
E	mm		260	260	260
	Inch		10-15/64	10-15/64	10-15/64

4 Layout Functional Components

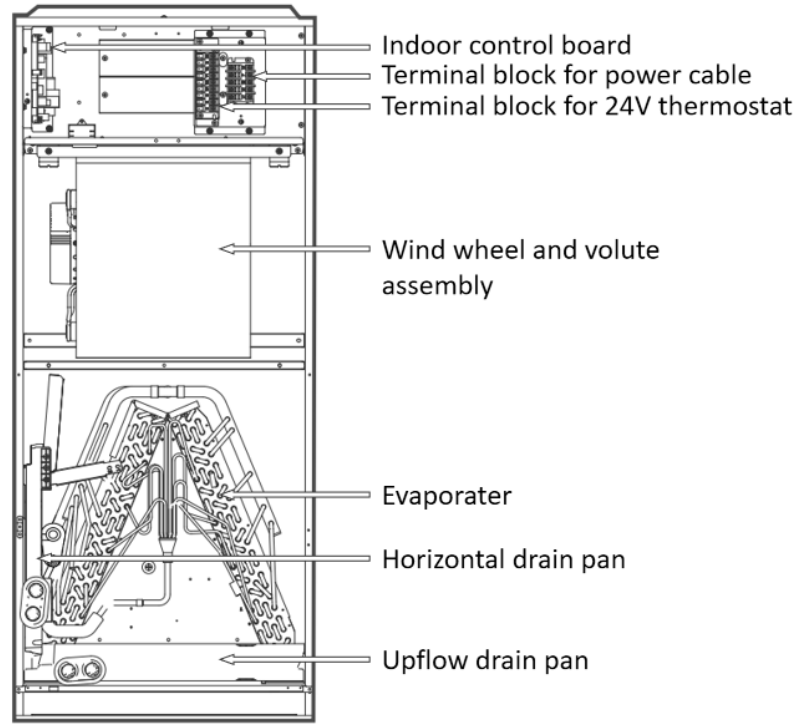
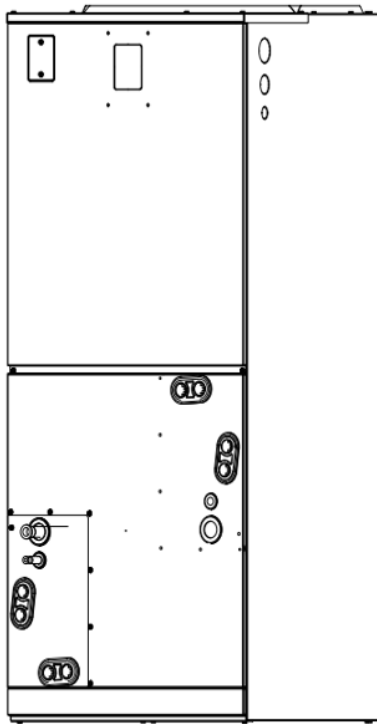

Part 2

Wiring Diagram

1 Electric wiring diagram	7
2 PCB	9
3 Low voltage wiring diagram	10
4 Electrical parameters	15

1 Electric wiring diagram

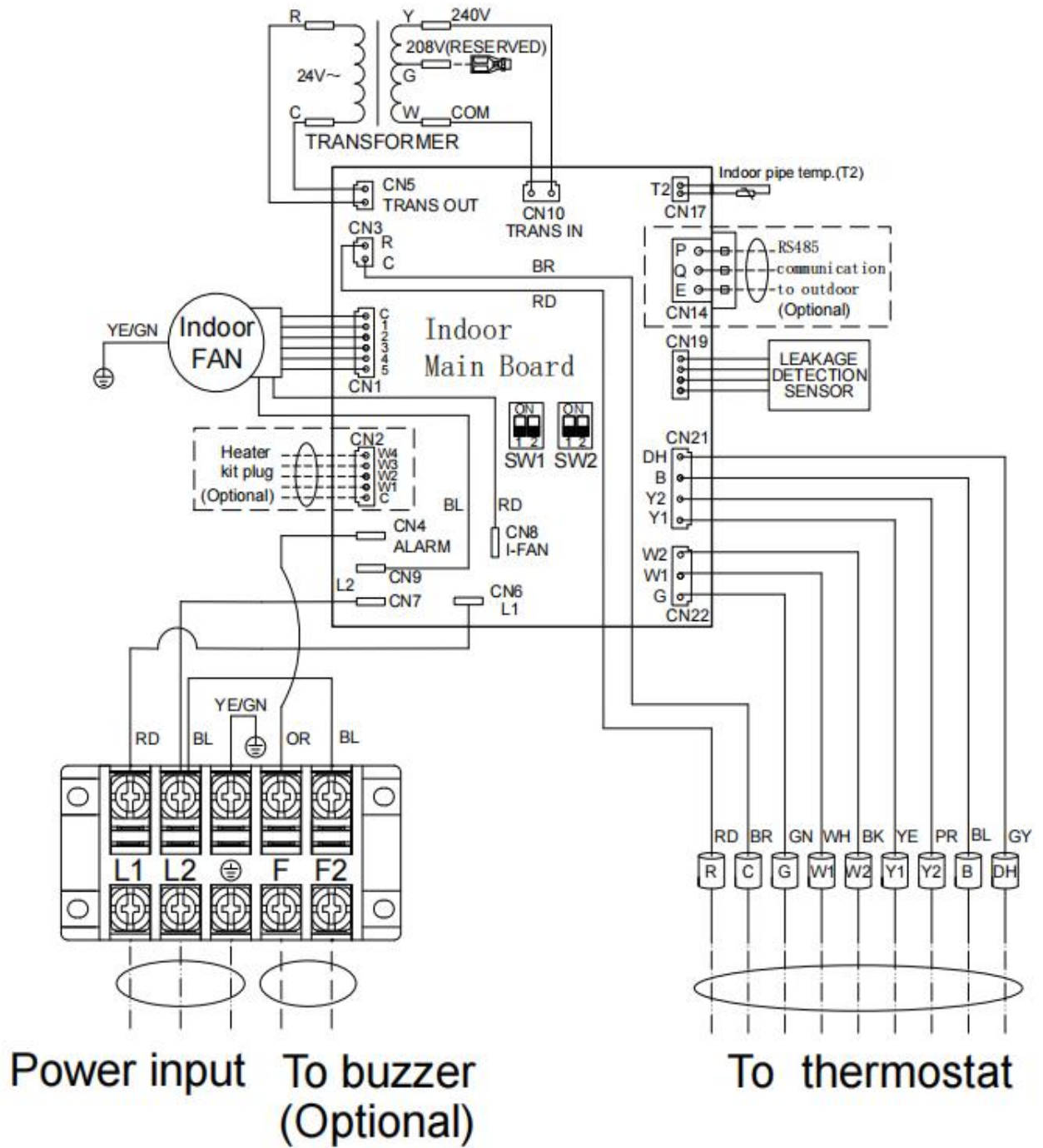

DIP switch status Indicate					
ON <input type="checkbox"/>	OFF <input checked="" type="checkbox"/>	1			This Indicate OFF (The DIP switch is dialed to the digital side)
ON <input checked="" type="checkbox"/>	OFF <input type="checkbox"/>	1			This Indicate ON (The DIP switch is dialed to the non-digital side)
SW1 DIP switch selection (Indoor FAN speed)					
SW1.1	SW1.2	High speed (G+B+Y1+Y2 OR G+Y1+Y2 OR W OR W1 OR W2)	Low speed (G+Y1 OR G+B+Y1 OR G)	Models	
OFF	OFF	2	1		
OFF	ON	3	3	42K	
ON	OFF	4	3	18K 30K 48K	
ON	ON	5	3	24K 36K 60K	

SW2 DIP switch selection		
SW2.1	OFF	24V Control (Default)
	ON	RS485 Comm. Mode
SW2.2	OFF	Reserved
	ON	Reserved
Wire Color Code		
RD	RED	OR ORANGE
BL	BLUE	GN GREEN
BR	BROWN	GY GRAY
BK	BLACK	YE YELLOW
WH	WHITE	PR PURPLE
LINE ANNOTATION		
—————	Factory wiring	
- - - - -	Field wiring	
- - - - -	Field wiring (Optional)	

2 PCB

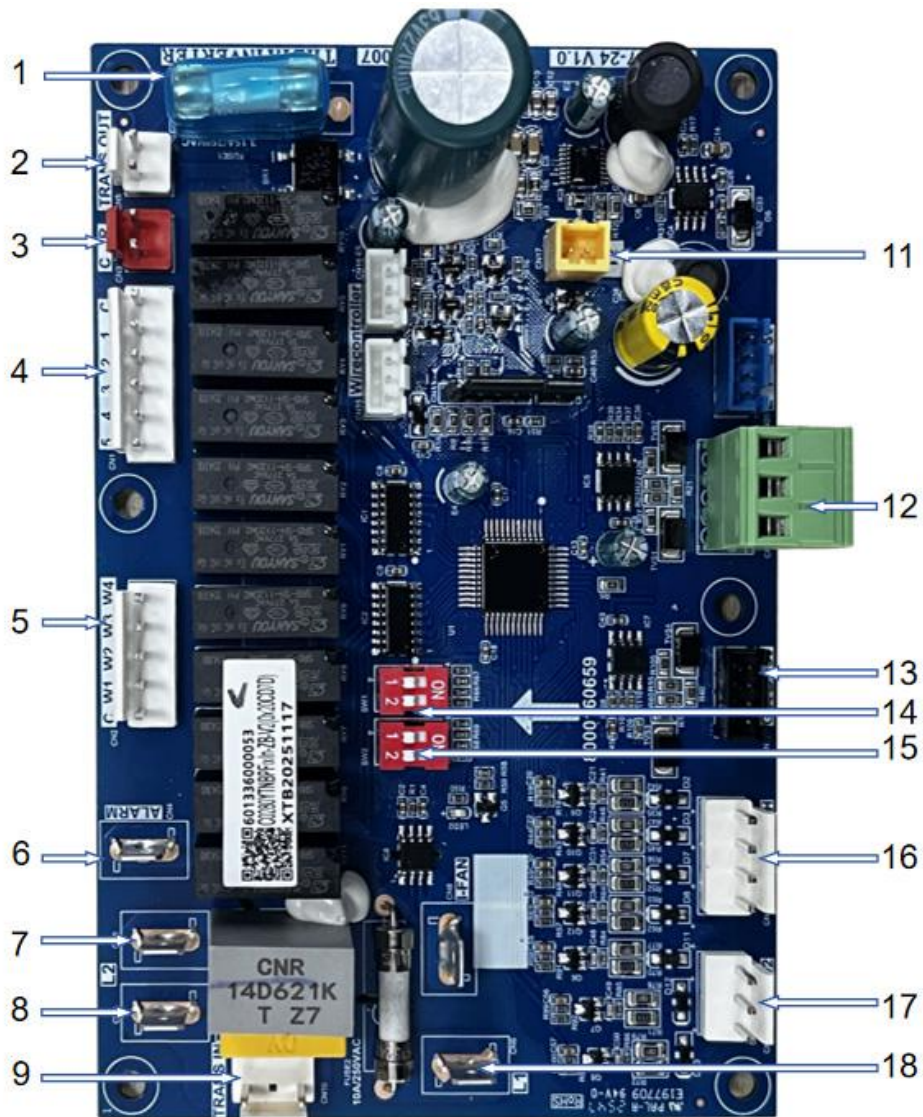

No.	Port Names and Definitions	No.	Port Names and Definitions
1	Fuse	11	Port for indoor coil temperature sensor T2
2	24V trans in from transformer	12	RS-485 communication port
3	Port to 24V thermostat(R/C)	13	Port for refrigerant concentration monitor
4	Port for electrical heater(reserved)	14	DIP Switch-SW1
5	Port for indoor fan motor	15	DIP Switch-SW2
6	Connect to "F" terminal of the terminal block	16	Port to 24V thermostat(DH/B/Y2/Y1)
7	Connect to indoor fan motor(optional)	17	Port to 24V thermostat(W2/W1/G)
8	Connect to power supply-L2	18	Connect to power supply-L1
9	220V trans out to transformer		

3 Low voltage wiring diagram

The following wiring diagram are suitable for the Indoor Unit and Outdoor Unit with 24V thermostat.

Wiring for 1H and 1C thermostat (no heat pump system model)

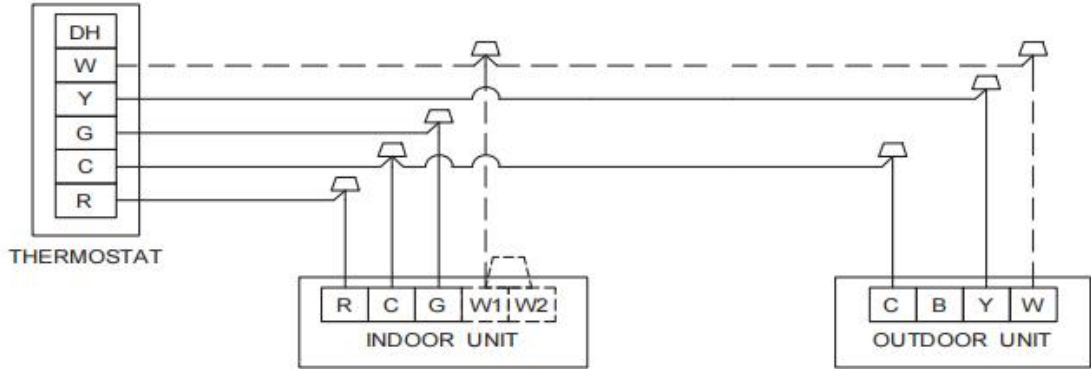

Wiring for 1H and 1C thermostat (no heat pump system model)

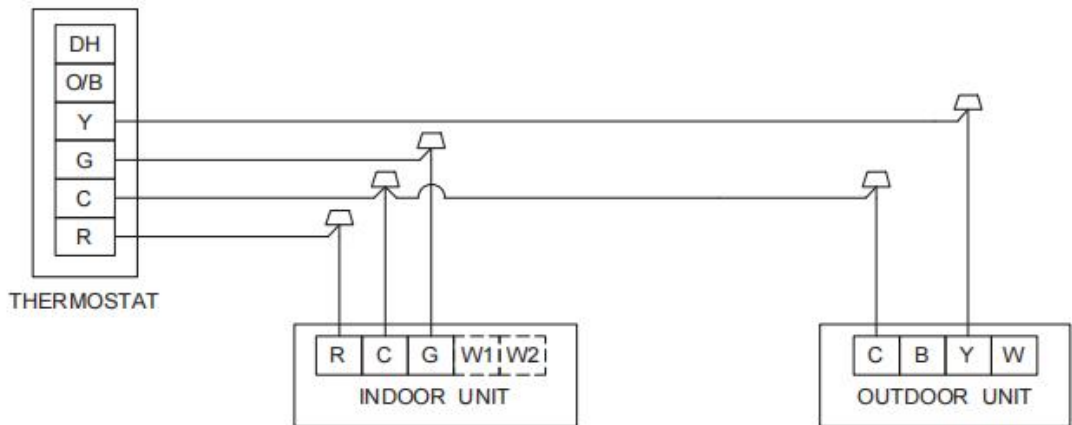

Wiring for 3H and 1C thermostat (no heat pump system model)

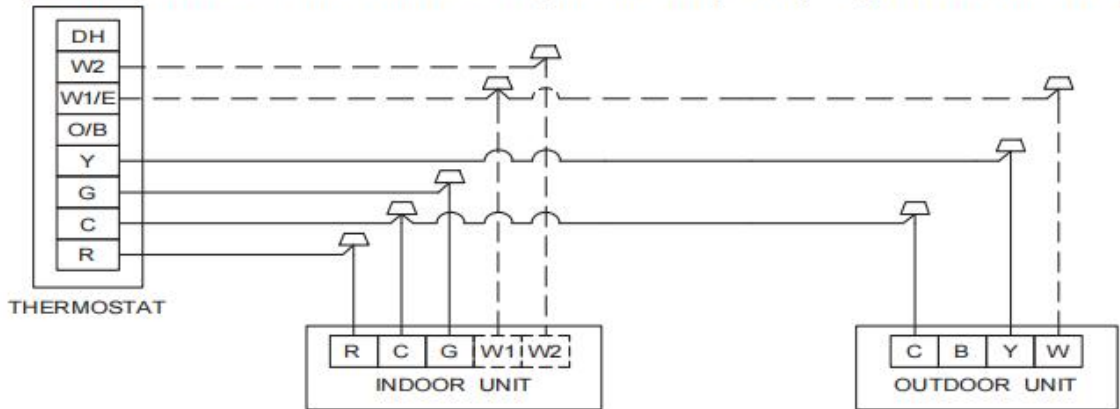

Wiring for 2H and 1C thermostat (no heat pump system model)

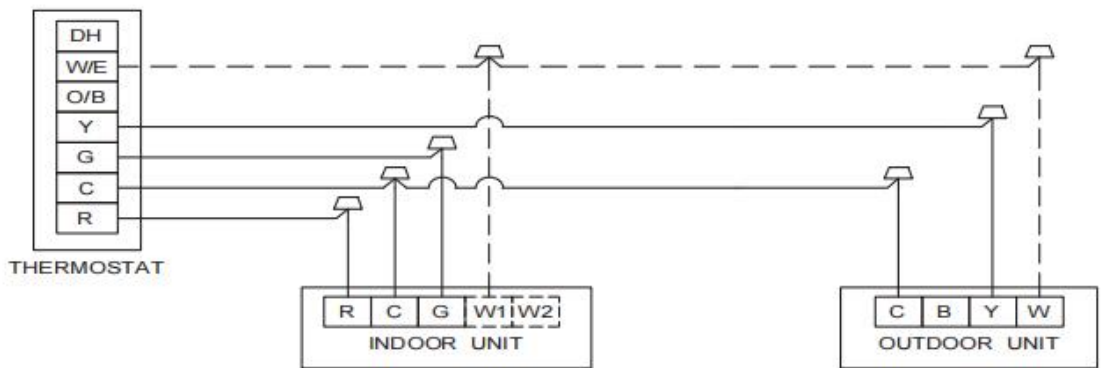

Wiring for 3H and 2C thermostat (no heat pump system model)

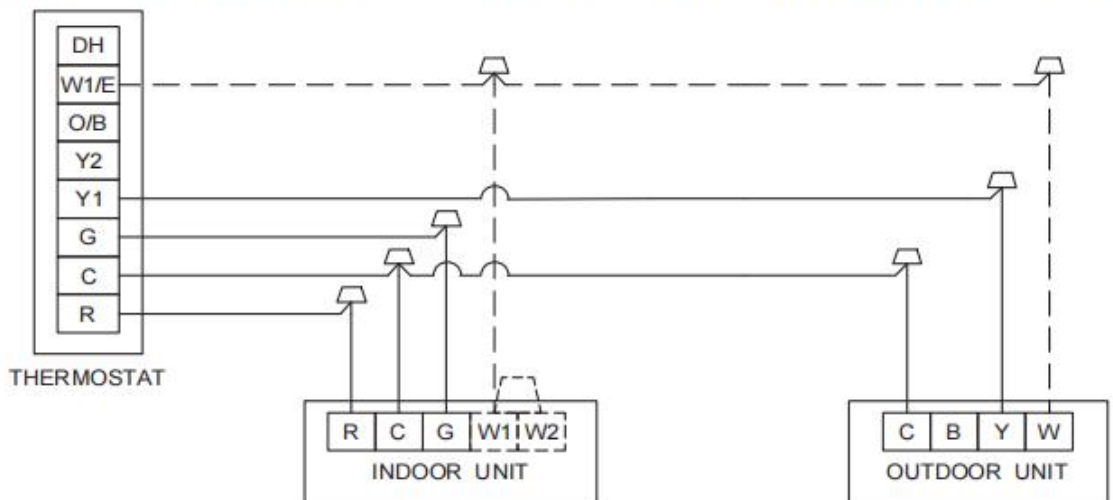

Wiring for 2H and 2C thermostat (no heat pump system model)

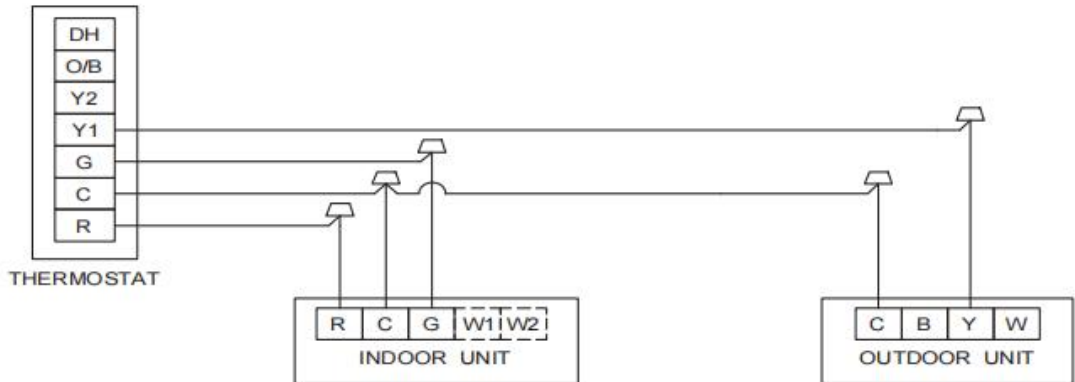

Wiring for 4H and 2C thermostat (no heat pump system model)

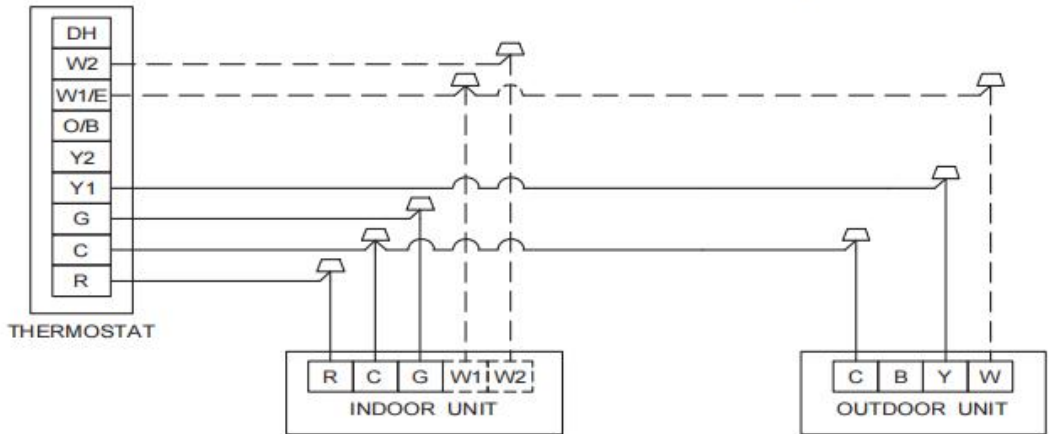

Heat Pump System Model

Wiring for 1H and 1C thermostat (heat pump system model)

Note: Because Y1 and Y2 are jumped, the indoor fan will only run in high stage.

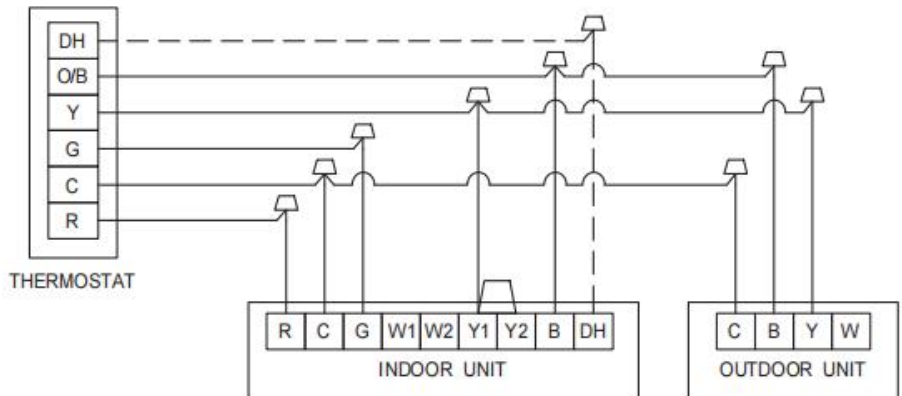

Wiring for 3H and 1C thermostat (heat pump system model)

Note: Because Y1 and Y2 are jumped, the indoor fan will only run in high stage.
 Note: Any time the electric heat elements are active, the indoor fan will run in high stage.

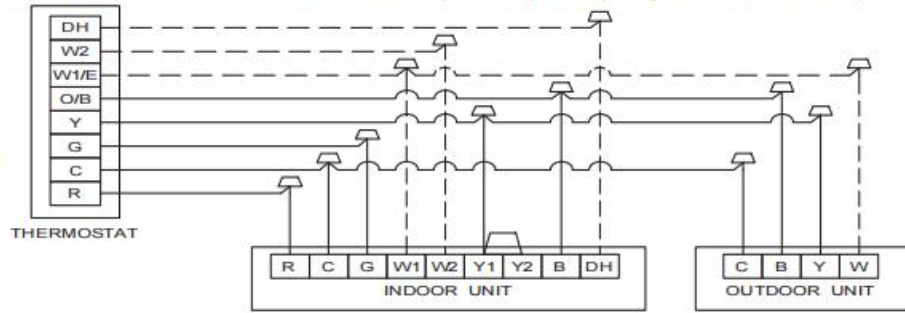

Wiring for 2H and 1C thermostat (heat pump system model)

Note: Because Y1 and Y2 are jumped, the indoor fan will only run in high stage.
 Note: Any time the electric heat elements are active, the indoor fan will run in high stage.

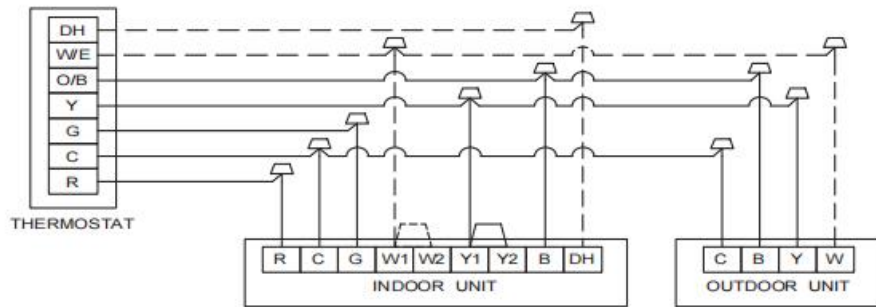

Wiring for 3H and 2C thermostat (heat pump system model)

Note: Y1 and Y2 here represents 2 stages of fan cooling only, the compressor modulates separately from the fan.
 Note: Any time the electric heat elements are active, the indoor fan will run in high stage.

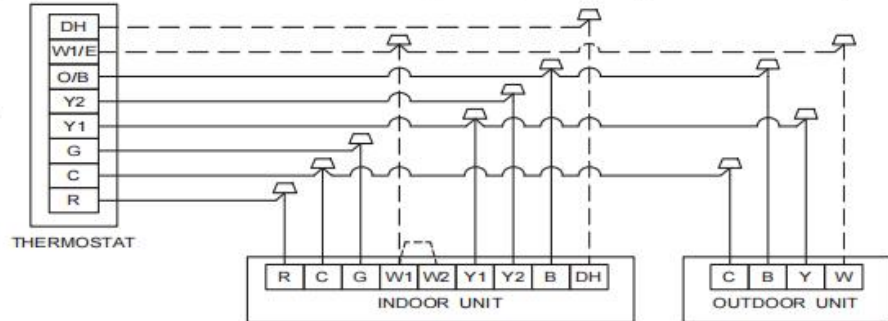

Wiring for 2H and 2C thermostat (heat pump system model)

Note: Y1 and Y2 here represents 2 stages of fan cooling only, the compressor modulates separately from the fan.

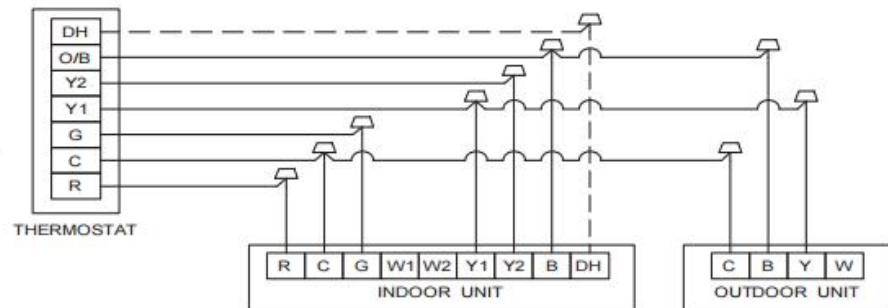

Wiring for 4H and 2C thermostat (heat pump system model)

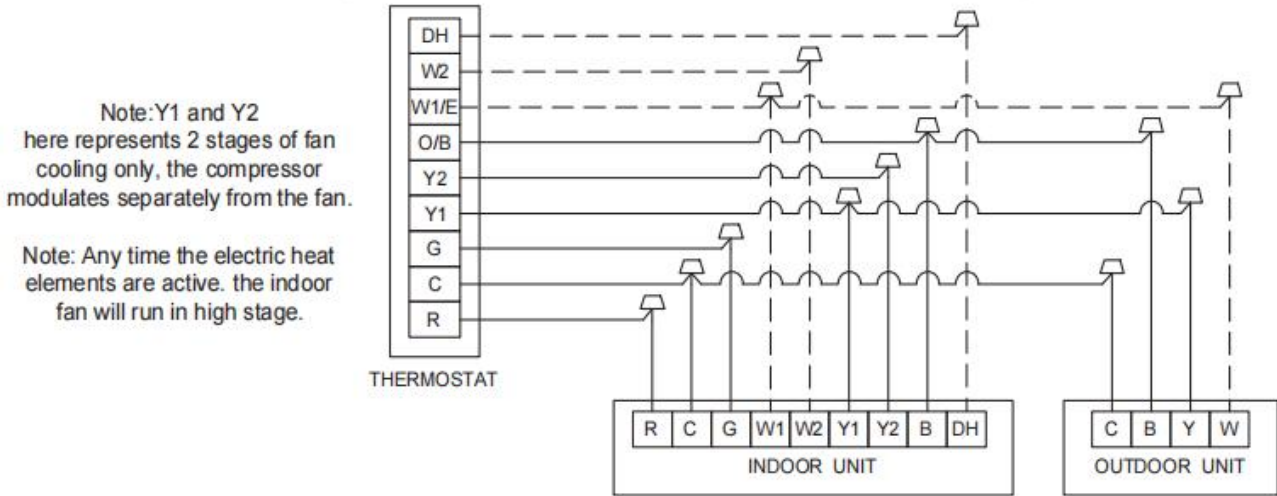

Control Logic:

Indoor unit connector

Connector	Purpose
R	24V Power Connection
C	Common
G	Fan Control
Y1	Low Cooling
Y2	High Cooling
B	Heating Reversing Valve
W1	Stage1 Electrical Heating
W2	Stage2 Electrical Heating
DH	Dehumidification

Outdoor unit connector

Connector	Purpose
C	Common
Y	Cooling
B	Heating Reversing Valve
W	Defrost Control

Note:

- 1) DH wiring is optional and requires a thermostat with a humidistat. DH functions as Passive Dehumidification and will downstage the indoor fan to first stage. System will operate according to normal sequence of operations if DH wiring is absent.
- 2) Dashed lines in the above thermostat wiring diagrams refer to optional wiring (wiring for Passive Dehumidification Function and/OR Electric Heat). For thermostat wiring please refer to the Owner's Manual of the thermostat.
- 3) B wire must be used with heat pump system only, the reversing valve energizes in heating.

4 Electrical parameters

Capacity(Btu/h)		18K	24K	30K	36K	42k	48k	60k
Power	Phase	1	1	1	1	1	1	1
(Indoor)	Frequency and Volt	208/230,60Hz						
Power	Phase	1	1	1	1	1	1	1
(Outdoor)	Frequency and Volt	208/230,60Hz						
Max.Fuse	Indoor unit(A)	6	6	6	6	10	10	10
	Outdoor unit(A)	15	15	25	30	35	40	50
Indoor unit	Line quantity	3	3	3	3	3	3	3
Powerline	Line diameter(AWG)	14/2.1mm ²	14/2.1mm ²	14/2.1mm ²	14/2.1mm ²	14/2.1mm ²	14/2.1mm ²	14/2.1mm ²
Outdoor unit	Line quantity	3	3	3	3	3	3	3
Powerline	Line diameter(AWG)	14/2.1mm ²	12/3.3mm ²	12/3.3mm ²	10/5.3mm ²	8/8.4mm ²	8/8.4mm ²	8/8.4mm ²
Outdoor unit	Line quantity	3	3	3	3	3	3	3
Signal line	Line diameter(AWG)	20/0.5mm ²	20/0.5mm ²	20/0.5mm ²	20/0.5mm ²	20/0.5mm ²	20/0.5mm ²	20/0.5mm ²
Thermostat	Line quantity	/	/	/	/	/	/	/
Signal line	Line diameter(AWG)	18/0.8mm ²	18/0.8mm ²	18/0.8mm ²	18/0.8mm ²	18/0.8mm ²	18/0.8mm ²	18/0.8mm ²

Part 3

Diagnosis and Troubleshooting

1 Error code table	17
2 Troubleshooting	18
2.1 Safety Precautions	18
2.2 T1/T2 temperature sensor fault troubleshooting	21
2.3 Refrigerant concentration sensor fault troubleshooting	22
2.4 Refrigerant leakage protection troubleshooting	23
2.5 Anti-freeze protection troubleshooting	24
2.6 Indoor fan motor fault troubleshooting	25
2.7 Communication error between outdoor and indoor unit troubleshooting	26
2.8 Wired controller communication error troubleshooting	27
3. Temperature Sensor Resistance Characteristics	28

1 Error code table

Error code	Error definition
Flash for 3 times every 8 seconds	T2 temperature sensor fault
Flash for 4 times every 8 seconds	R32 refrigerant concentration sensor fault
Flash for 5 times every 8 seconds	R32 refrigerant leakage protection
Flash for 6 times every 8 seconds	Anti-freeze protection
Flash for 8 times every 8 seconds	Indoor fan motor fault
Flash for 9 times every 8 seconds	Communication error between outdoor and indoor unit
Flash for 10 times every 8 seconds	Wired controller communication error

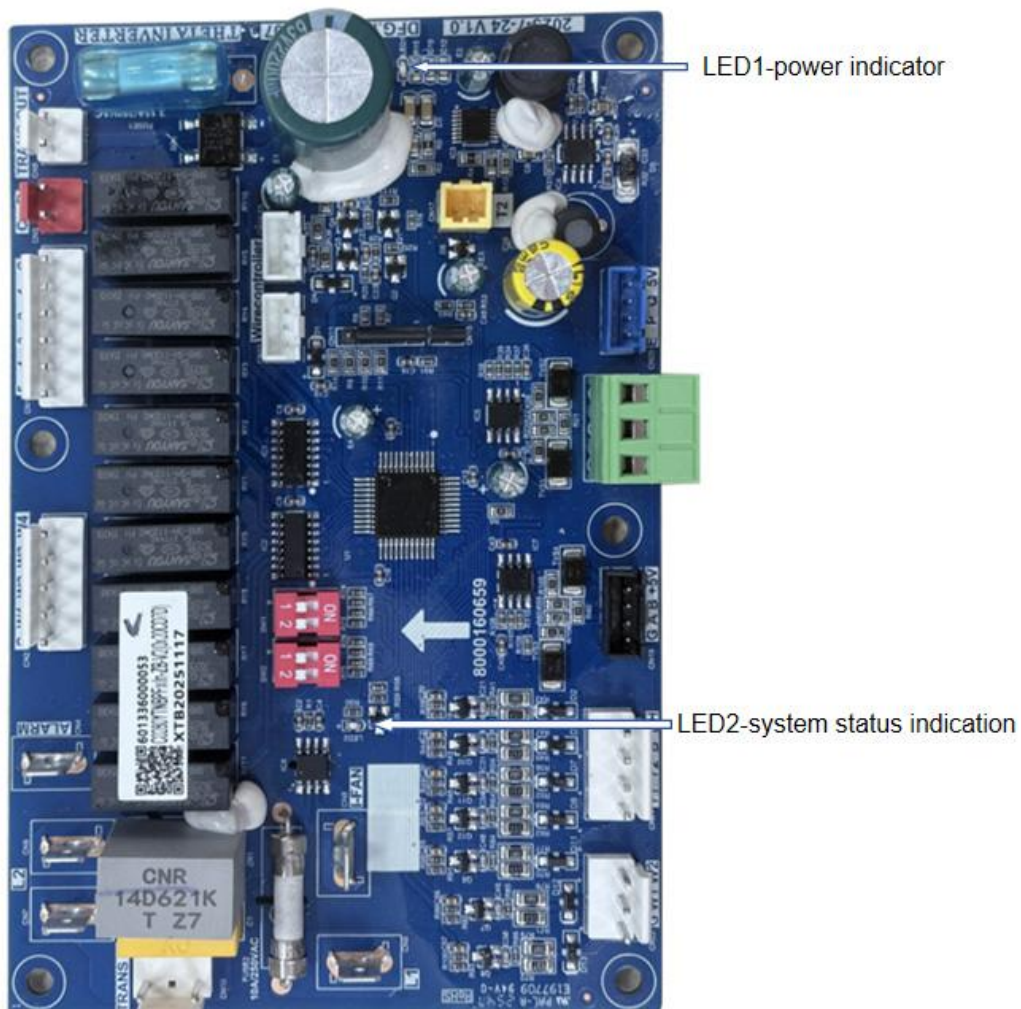

Note: In normal operation, LED1 and LED2 are steady on; when the system is standby, LED1 will be steady on, LED2 will flash slowly.

2 Troubleshooting

2.1 Safety Precautions

The following precautions here are quite important, so be sure to follow them carefully. Read these instructions carefully before installation. Keep this manual in a handy for future preference.

Failure to adhere to all precautionary measures listed in this section may result in personal injury, damage to the unit or to property, or in extreme cases, death.



WARNING

- Indicates a potentially hazardous situation which if not avoided, could result in death or serious injury.



CAUTION

- Indicates a potentially hazardous situation which if not avoided, may result in minor or moderate injury.
- It is also used to alert against unsafe practices.

2.1.1 In case of Accidents or Emergency



WARNING

- If a gas leak is suspected, immediately turn off the gas and ventilate the area if a gas leak is suspected before turning the unit on.
- If strange sounds or smoke is detected from the unit, turn the breaker off and disconnect the power supply cable.
- If the unit comes into contact with liquid, contact an authorized service center.
- If liquid from the batteries makes contact with skin or clothing, immediately rinse or wash the area well with clean water.
- Do not insert hands or other objects into the air inlet or outlet while the unit is plugged in.
- Do not operate the unit with wet hands.



CAUTION

- Clean and ventilate the unit at regular intervals when operating it near a stove or near similar devices.
- Do not use the unit during severe weather conditions. If possible, remove the product from the window before such occurrences.

2.1.2 Information servicing(For flammable materials)



WARNING

- Use this unit only on a dedicated circuit.
 - Damage to the installation area could cause the unit to fall, potentially resulting in personal injury, property damage, or product failure.
 - Only qualified personnel should disassemble, install, remove, or repair the unit.
 - Only a qualified electrician should perform electrical work. For more information, contact your dealer, seller, or an authorized service center.
-



CAUTION

- While unpacking be careful of sharp edges around the unit as well as the edges of the fins on the condenser and evaporator.

2.1.3 Operation and Maintenance



WARNING

- Do not use defective or under-rated circuit breakers.
- Ensure the unit is properly grounded and that a dedicated circuit and breaker are installed.
- Do not modify or extend the power cable. Ensure the power cable is secure and not damaged during operation.
- Do not unplug the power supply plug during operation.
- Do not store or use flammable materials near the unit.
- Do not open the inlet grill of the unit during operation.
- Do not touch the electrostatic filter if the unit is equipped with one.
- Do not block the inlet or outlet of air flow to the unit.
- Do not use harsh detergents, solvents, or similar items to clean the unit. Use a soft cloth for cleaning.
- Do not touch the metal parts of the unit when removing the air filter as they are very sharp.
- Do not step on or place anything on the unit or outdoor units.
- Do not drink water drained from the unit.
- Avoid direct skin contact with water drained from the unit.

- Use a firm stool or step ladder according to manufacturer procedures when cleaning or maintaining the unit.



CAUTION

- Do not install or operate the unit for an extended period of time in areas of high humidity or in an environment directly exposing it to sea wind or salt spray.
- Do not install the unit on a defective or damaged installation stand, or in an unsecured location.
- Ensure the unit is installed at a level position
- Do not install the unit where noise or air discharge
- Created by the outdoor unit will negatively impact the environment or nearby residences.
- Do not expose skin directly to the air discharged by the unit for prolonged periods of time.
- Ensure the unit operates in areas waterOr other liquids.
- Ensure the drain hose is installed correctly to ensure proper water drainage.
- When lifting or transporting the unit, it is recommended that two or more people are used for this task.
- When the unit is not to be used for an extended time, disconnect the power supply or turn off the breaker.

2.2 T2 temperature sensor fault troubleshooting

- LED2 flashes for 3 times every 8 seconds indicates indoor unit T2 temperature sensor fault
- The unit stops running and LED2 flashes 2 or 3 times in each round.

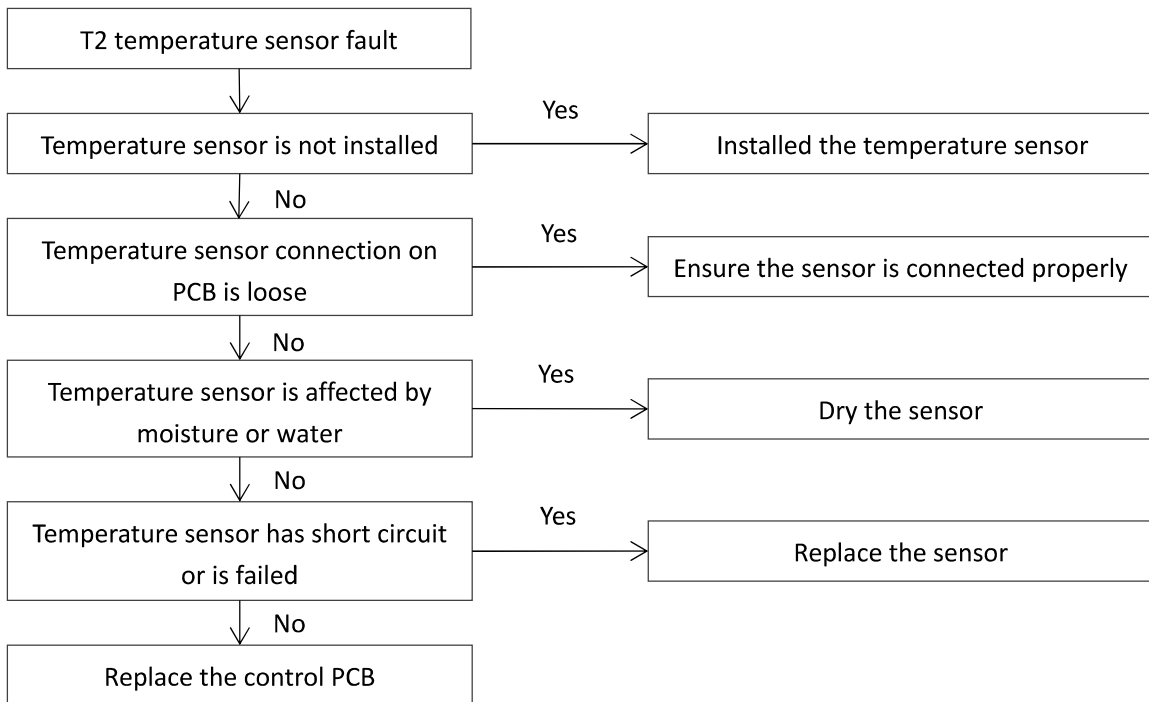

Note: Measure sensor resistance. If the resistance is too low, the sensor has short-circuited. If the resistance is not consistent with the sensor's resistance characteristics table, the sensor has failed.

2.3 Refrigerant concentration sensor fault troubleshooting

- LED2 flash for 4 times every 8 seconds indicates refrigerant concentration sensor fault (Only valid when connected to a refrigerant concentration sensor.)
- The unit stops running and LED2 flashes 4 times in each round.

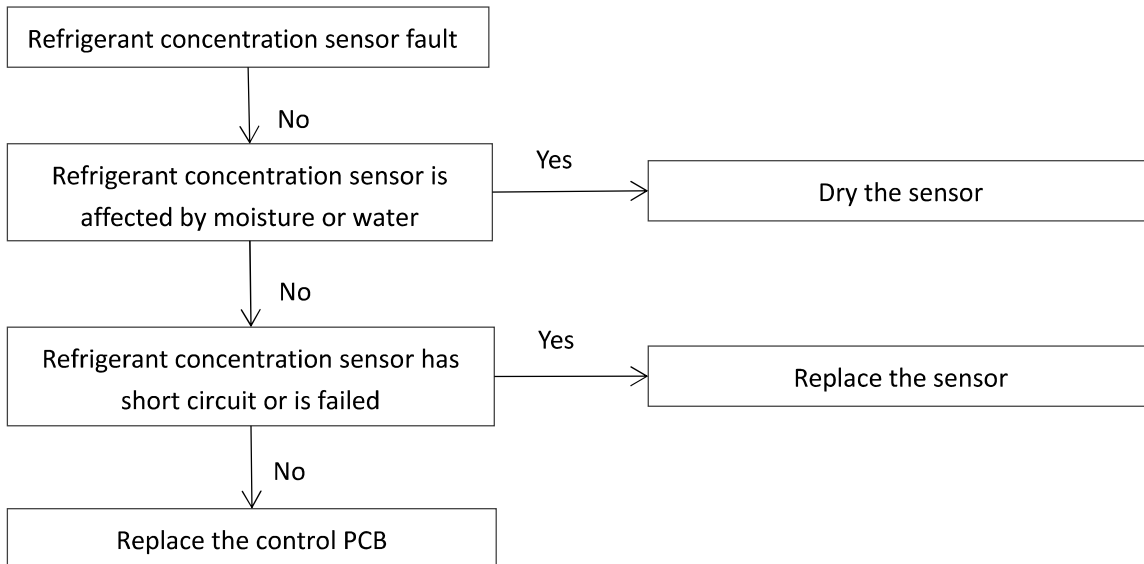

2.4 Refrigerant leakage protection troubleshooting

- LED2 flashes for 5 times every 8 seconds indicates refrigerant leakage protection (Only valid when connected to a refrigerant concentration sensor.)
- The unit stops running and error code is displayed on LED2 flashes 5 times in each round.

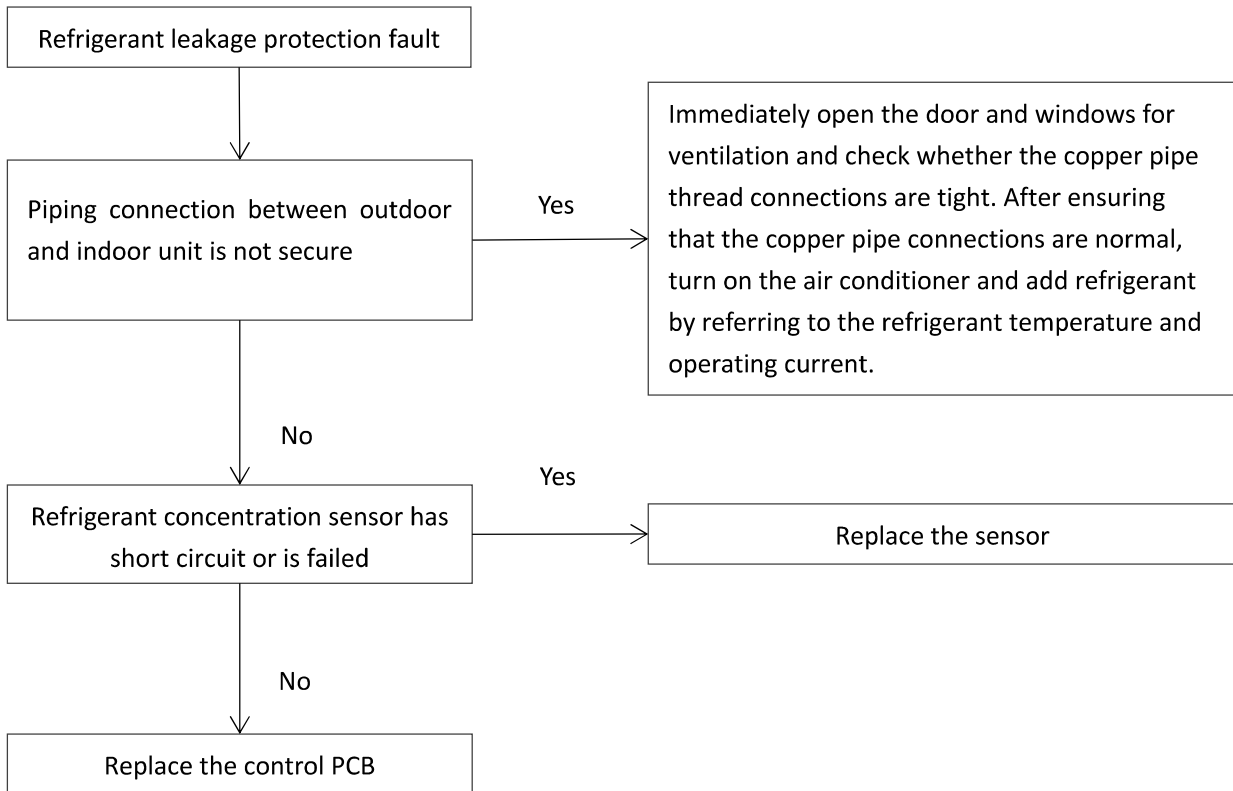

Note:

- 1) Measure sensor resistance. If the resistance is too low, the sensor has short-circuited. If the resistance is not consistent with the sensor's resistance characteristics table, the sensor has failed.

2.5 Anti-freeze protection troubleshooting

- LED2 flashes 6 times every 8 seconds indicates anti-freeze protection.
- The unit stops running and LED2 flashes 6 times in each round.

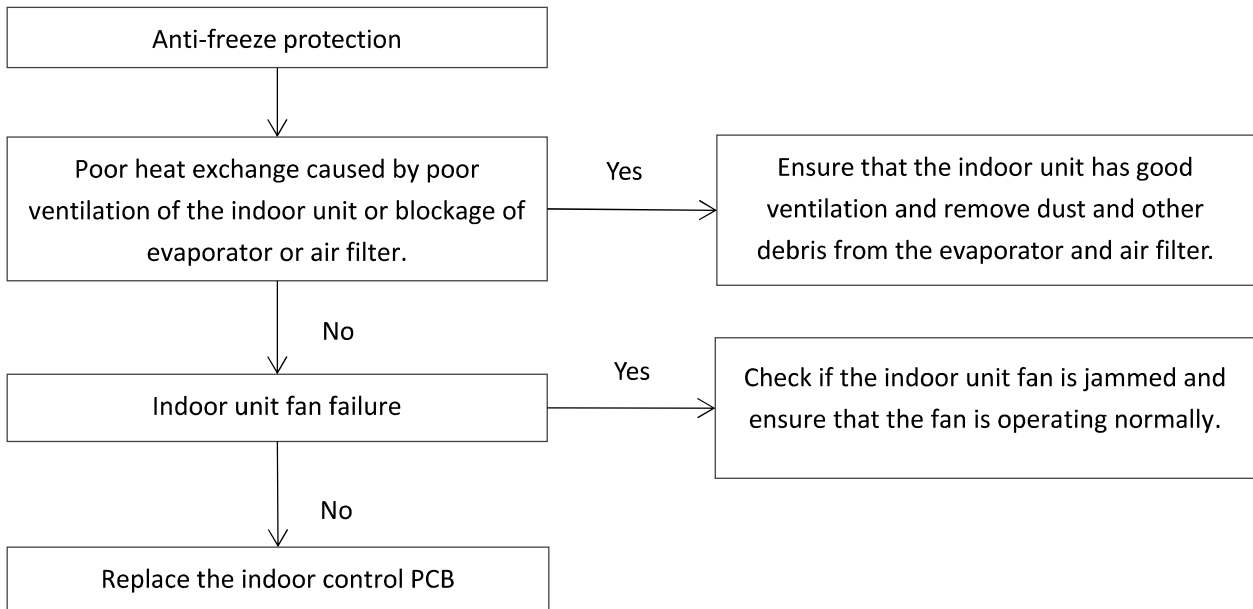

2.6 Indoor fan motor fault troubleshooting

- LED2 flashes 8 times every 8 seconds indicates indoor fan motor fault.
- The unit stops running and LED2 flashes 8 times in each round.

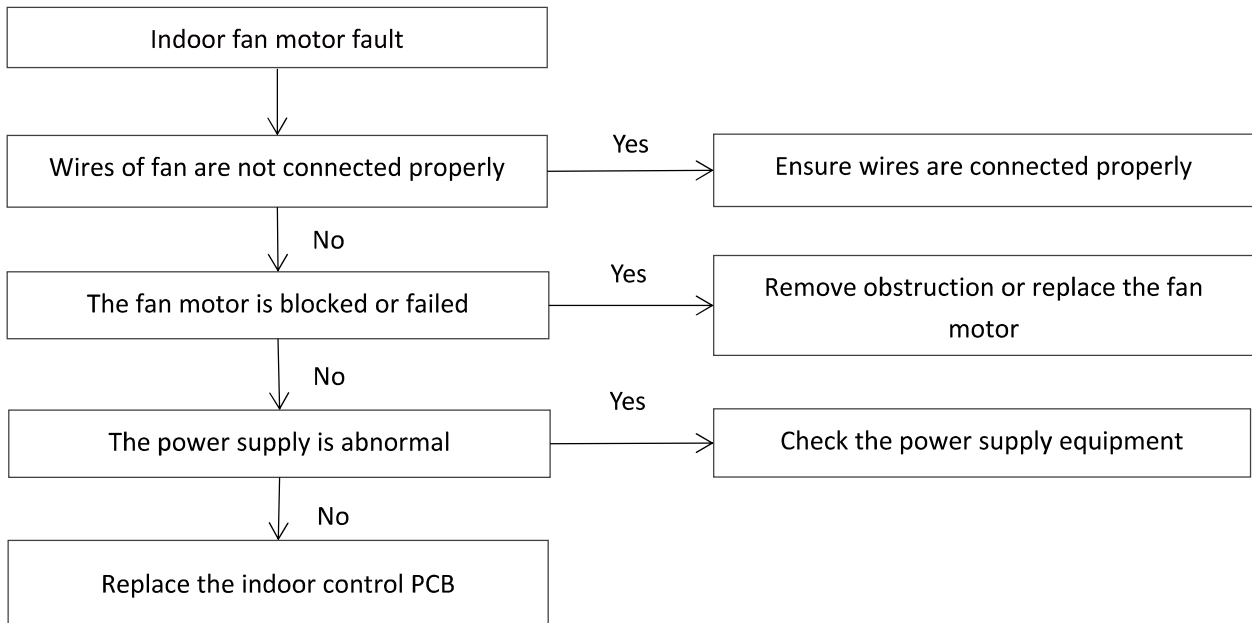

2.7 Communication error between outdoor and indoor unit troubleshooting

- LED2 flashes 9 times every 8 seconds indicates communication error between outdoor and indoor unit.
- The unit stops running and LED2 flashes 9 times in each round.

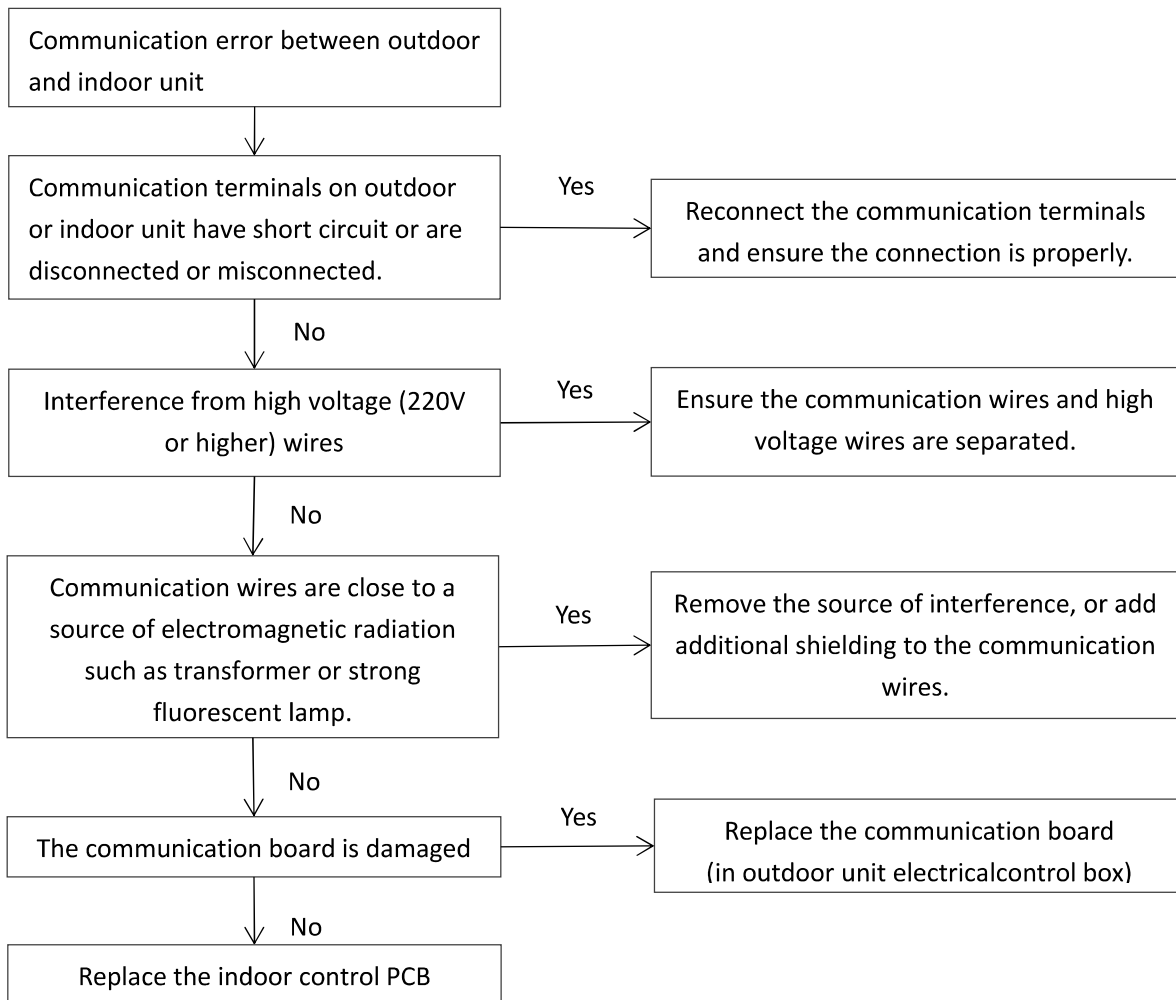

2.8 Wired controller communication error troubleshooting

- LED2 flashes 10 times every 8 seconds indicates wired controller communication error.
- The unit stops running and LED2 flashes 10 times in each round.

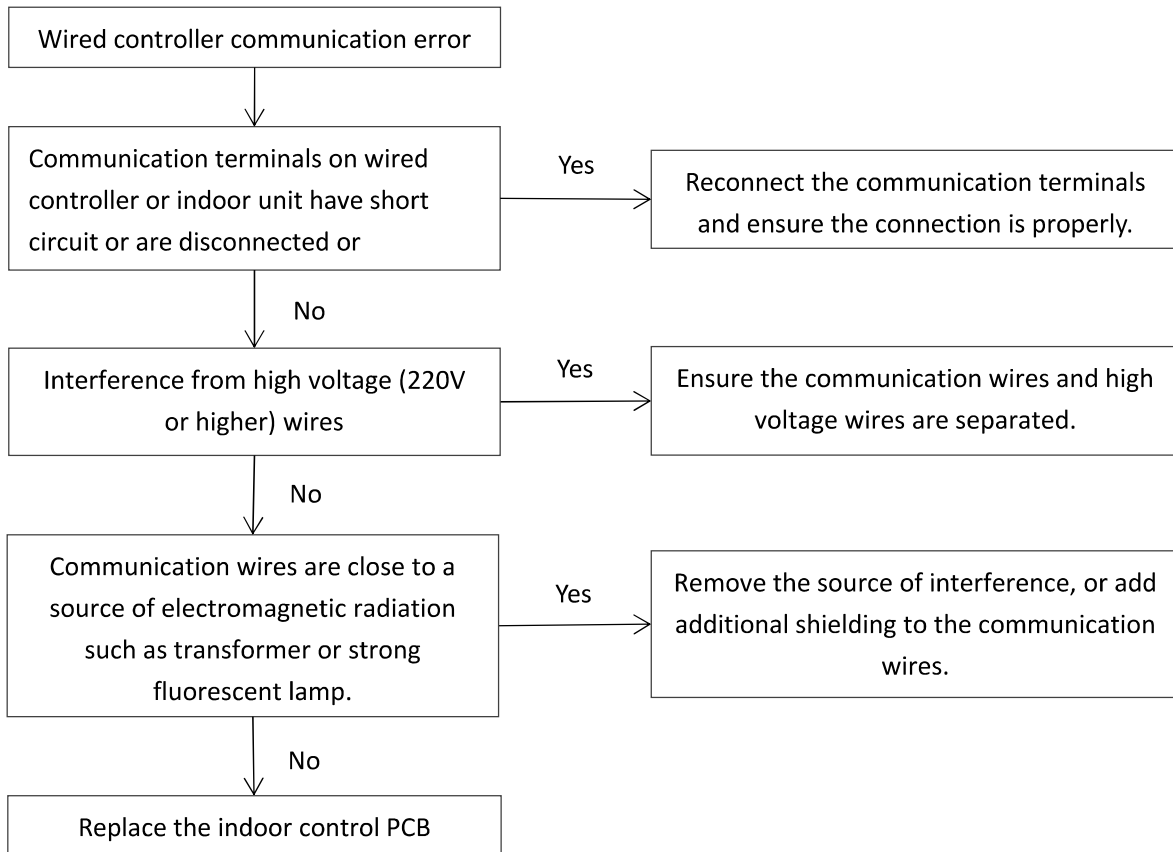

3. Temperature Sensor Resistance Characteristics

Room temperature sensor(T1) and condenser coil temperature sensor(T2) resistance characteristics.

Temperature (°C)	Temperature (°F)	Resistance (kQ)	Temperature (°C)	Temperature (°F)	Resistance (kQ)
-25	-13	144.266	15	59	16.079
-24	-11	135.601	16	61	15.313
-23	-9	127.507	17	63	14.588
-22	-8	119.941	18	64	13.902
-21	-6	112.867	19	66	13.251
-20	-4	106.732	20	68	12.635
-19	-2	100.552	21	70	12.05
-18	0	94.769	22	72	11.496
-17	1	89.353	23	73	10.971
-16	3	84.278	24	75	10.473
-15	5	79.521	25	77	10
-14	7	75.059	26	79	9.551
-13	9	70.873	27	81	9.125
-12	10	66.943	28	82	8.721
-11	12	63.252	29	84	8.337
-10	14	59.784	30	86	7.972
-9	16	56.524	31	88	7.625
-8	18	53.458	32	90	7.296
-7	19	50.575	33	91	6.982
-6	21	47.862	34	93	6.684
-5	23	45.308	35	95	6.401
-4	25	42.903	36	97	6.131
-3	27	40.638	37	99	5.874
-2	28	38.504	38	100	5.63
-1	30	36.492	39	102	5.397
0	32	34.596	40	104	5.175
1	34	32.807	41	106	4.964
2	36	31.12	42	108	4.763
3	37	29.528	43	109	4.571
4	39	28.026	44	111	4.387
5	41	26.608	45	113	4.213
6	43	25.268	46	115	4.046
7	45	24.003	47	117	3.887
8	46	22.808	48	118	3.735
9	48	21.678	49	120	3.59
10	50	20.61	50	122	3.451
11	52	19.601	51	124	3.318
12	54	18.646	52	126	3.191
13	55	17.743	53	127	3.069
14	57	16.888	54	129	2.952

Temperature(°C)	Temperature(°F)	Resistance(kQ)	Temperature(°C)	Temperature(°F)	Resistance(kQ)
55	131	2.841	95	171	0.708
56	133	2.734	96	173	0.686
57	135	2.632	97	175	0.666
58	136	2.534	98	176	0.646
59	138	2.44	99	178	0.627
60	140	2.35	100	180	0.609
61	142	2.264	101	182	0.591
62	144	2.181	102	184	0.574
63	145	2.102	103	185	0.558
64	147	2.026	104	187	0.542
65	149	1.953	105	189	0.527
66	151	1.883			
67	153	1.816			
68	154	1.752			
69	156	1.69			
70	158	1.631			
71	160	1.574			
72	162	1.519			
73	163	1.466			
74	165	1.416			
75	167	1.367			
76	169	1.321			
77	171	1.276			
78	172	1.233			
79	174	1.191			
80	176	1.151			
81	178	1.113			
82	180	1.076			
83	181	1.041			
84	183	1.007			
85	185	0.974			
86	187	0.942			
87	189	0.912			
88	190	0.883			
89	192	0.855			
90	194	0.828			
91	196	0.802			
92	198	0.777			
93	199	0.753			
94	201	0.73			