



SERVICE MANUAL

AIR HANDLER INVERTER SERIES

Indoor Unit			Outdoor Unit		
AHU18-SG2	0PK	CPR18CD(O)	0XT	CPH18CD(O)	07B
AHU24-SG2	0RV	CPR24CD(O)	0S1	CPH24CD(O)	08B
AHU30-SG2	0RW	CPR30CD(O)	0S2	CPH30CD(O)	09B
AHU36-SG2	0RX	CPR36CD(O)	0S3	CPH36CD(O)	01C
AHU48-SG2	0RY	CPR48CD(O)	0S4	CPH48CD(O)	02C
AHU60-SG2	0RZ	CPR60CD(O)	0S5	CPH60CD(O)	03C

Table of Contents

§. Safety Precautions

1. Precautions
2. Information servicing

§. Model Reference & External Appearance

1. Model Reference
2. External Appearance

§. Indoor Unit

1. Indoor Unit - Air Handler Type

§. Outdoor Unit

1. Dimensional Drawings
2. Service Space
3. Capacity Correction Factor for Height Difference
4. Noise Criterion Curves
5. Refrigerant Cycle Diagrams
6. Electrical Wiring Diagrams

§. Installation

§. Maintenance

§. Product Features

Table of Contents

§. Troubleshooting

1. Safety Caution
2. General Troubleshooting
3. Outdoor Unit Point Check Function
4. Information Inquiry
5. Error Diagnosis and Troubleshooting Without Error Code
6. Quick Maintenance by Error Code
7. Troubleshooting by Error Code
8. Check Procedures

§. Indoor Unit Disassembly

1. Indoor Unit - Air Handler Type

§. Outdoor Unit Disassembly

Appendix

- i) Temperature Sensor Resistance Value Table for T1,T2,T3 and T4 (°C – K)
- ii) Temperature Sensor Resistance Value Table for TP(for some units) (°C – K)
- iii) Pressure On Service Port

Safety Precautions

Contents

1.	Precautions.....	2
2.	Information servicing(For flammable materials).....	3

1. Precautions

To prevent personal injury, or property or unit damage, adhere to all precautionary measures and instructions outlined in this manual. Before servicing a unit, refer to this service manual and its relevant sections.

Failure to adhere to all precautionary measures listed in this section may result in personal injury, damage to the unit or to property, or in extreme cases, death.

 **WARNING** indicates a potentially hazardous situation which if not avoided could result in serious personal injury, or death.

 **CAUTION** indicates a potentially hazardous situation which if not avoided could result in minor or moderate personal injury, or unit damage.

1.1 In case of Accidents or Emergency

 **WARNING**

- If a gas leak is suspected, immediately turn off the gas and ventilate the area if a gas leak is suspected before turning the unit on.
- If strange sounds or smoke is detected from the unit, turn the breaker off and disconnect the power supply cable.
- If the unit comes into contact with liquid, contact an authorized service center.
- If liquid from the batteries makes contact with skin or clothing, immediately rinse or wash the area well with clean water.
- Do not insert hands or other objects into the air inlet or outlet while the unit is plugged in.
- Do not operate the unit with wet hands.
- Do not use a remote controller that has previously been exposed to battery damage or battery leakage.

 **CAUTION**

- Clean and ventilate the unit at regular intervals when operating it near a stove or near similar devices.
- Do not use the unit during severe weather conditions. If possible, remove the product from the window before such occurrences.

1.2 Pre-Installation and Installation

 **WARNING**

- Use this unit only on a dedicated circuit.
- Damage to the installation area could cause the unit to fall, potentially resulting in personal injury, property damage, or product failure.
- Only qualified personnel should disassemble, install, remove, or repair the unit.
- Only a qualified electrician should perform electrical work. For more information, contact your dealer, seller, or an authorized service center.

 **CAUTION**

- While unpacking be careful of sharp edges around the unit as well as the edges of the fins on the condenser and evaporator.

1.3 Operation and Maintenance

 **WARNING**

- Do not use defective or under-rated circuit breakers.
- Ensure the unit is properly grounded and that a dedicated circuit and breaker are installed.
- Do not modify or extend the power cable. Ensure the power cable is secure and not damaged during operation.
- Do not unplug the power supply plug during operation.
- Do not store or use flammable materials near the unit.
- Do not open the inlet grill of the unit during operation.
- Do not touch the electrostatic filter if the unit is equipped with one.
- Do not block the inlet or outlet of air flow to the unit.
- Do not use harsh detergents, solvents, or similar items to clean the unit. Use a soft cloth for cleaning.
- Do not touch the metal parts of the unit when removing the air filter as they are very sharp.
- Do not step on or place anything on the unit or outdoor units.
- Do not drink water drained from the unit
- Avoid direct skin contact with water drained from the unit.
- Use a firm stool or step ladder according to manufacturer procedures when cleaning or maintaining the unit.

 **CAUTION**

- Do not install or operate the unit for an extended period of time in areas of high humidity or in an environment directly exposing it to sea wind or salt spray.
- Do not install the unit on a defective or damaged installation stand, or in an unsecure location.
- Ensure the unit is installed at a level position
- Do not install the unit where noise or air discharge created by the outdoor unit will negatively impact the environment or nearby residences.
- Do not expose skin directly to the air discharged by the unit for prolonged periods of time.
- Ensure the unit do not operate in areas water or other liquids.
- Ensure the drain hose is installed correctly to ensure proper water drainage.
- When lifting or transporting the unit, it is recommended that two or more people are used for this task.
- When the unit is not to be used for an extended time, disconnect the power supply or turn off the breaker.

2. Information servicing(For flammable materials)

2.1 Checks to the area

- Prior to beginning work on systems containing flammable refrigerants, safety checks are necessary to ensure that the risk of ignition is minimized. For repair to the refrigerating system, the following precautions shall be complied with prior to conducting work on the system.

2.2 Work procedure

- Works shall be undertaken under a controlled procedure so as to minimise the risk of a flammable gas or vapour being present while the work is being performed. Technical personnel in charge of operation, supervision, maintenance of air-conditioning systems shall be adequately instructed and competent with respect to their tasks. Works shall be undertaken with appropriate tools only (In case of uncertainty, please consult the manufacturer of the tools for use with flammable refrigerants)

2.3 General work area

- All maintenance staff and others working in the local area shall be instructed on the nature of work being carried out. work in confined spaces shall be avoided. The area around the work space shall be sectioned off. Ensure that the conditions within the area have been made safe by control of flammable material.

2.4 Checking for presence of refrigerant

- The area shall be checked with an appropriate refrigerant detector prior to and during work, to ensure the technician is aware of potentially flammable atmospheres. Ensure that the leak detection equipment being used is suitable for use with flammable refrigerants, i.e. no sparking, adequately sealed or intrinsically safe.

2.5 Presence of fire extinguisher

- If any hot work is to be conducted on the refrigeration equipment or any associated parts, appropriate fire extinguishing equipment shall be available to hand. Have a dry powder or CO2 fire extinguisher adjacent to the charging area.

2.6 No ignition sources

- No person carrying out work in relation to a refrigeration system which involves exposing any pipe work that contains or has contained flammable refrigerant shall use any sources of ignition in such a manner that it may lead to the risk of fire or explosion. All possible ignition sources, including cigarette smoking, should be kept sufficiently far away from the site of installation, repairing, removing and disposal, during which flammable refrigerant can possibly be released

to the surrounding space. Prior to work taking place, the area around the equipment is to be surveyed to make sure that there are no flammable hazards or ignition risks. NO SMOKING signs shall be displayed.

2.7 Ventilated area

- Ensure that the area is in the open or that it is adequately ventilated before breaking into the system or conducting any hot work. A degree of ventilation shall continue during the period that the work is carried out. The ventilation should safely disperse any released refrigerant and preferably expel it externally into the atmosphere.

2.8 Checks to the refrigeration equipment

- Where electrical components are being changed, they shall be fit for the purpose and to the correct specification. At all times the manufacturer's maintenance and service guidelines shall be followed. If in doubt consult the manufacturer's technical department for assistance. The following checks shall be applied to installations using flammable refrigerants:
 - the charge size is in accordance with the room size within which the refrigerant containing parts are installed;
 - the ventilation machinery and outlets are operating adequately and are not obstructed;
 - if an indirect refrigerating circuit is being used, the secondary circuit shall be checked for the presence of refrigerant; marking to the equipment continues to be visible and legible.
 - markings and signs that are illegible shall be corrected;
 - refrigeration pipe or components are installed in a position where they are unlikely to be exposed to any substance which may corrode refrigerant containing components, unless the components are constructed of materials which are inherently resistant to being corroded or are suitably protected against being so corroded.

2.9 Checks to electrical devices

- Repair and maintenance to electrical components shall include initial safety checks and component inspection procedures. If a fault exists that could compromise safety, then no electrical supply shall be connected to the circuit until it is satisfactorily dealt with. If the fault cannot be corrected immediately but it is necessary to continue operation, and adequate temporary solution shall be used. This shall be reported to the owner of the equipment so all parties are advised.

Initial safety checks shall include:

- that capacitors are discharged: this shall be done in a safe manner to avoid possibility of sparking
- that there no live electrical components and wiring are exposed while charging, recovering or purging the system;
- that there is continuity of earth bonding.

2.10 Repairs to sealed components

- During repairs to sealed components, all electrical supplies shall be disconnected from the equipment being worked upon prior to any removal of sealed covers, etc. If it is absolutely necessary to have an electrical supply to equipment during servicing, then a permanently operating form of leak detection shall be located at the most critical point to warn of a potentially hazardous situation.
- Particular attention shall be paid to the following to ensure that by working on electrical components, the casing is not altered in such a way that the level of protection is affected. This shall include damage to cables, excessive number of connections, terminals not made to original specification, damage to seals, incorrect fitting of glands, etc.
 - Ensure that apparatus is mounted securely.
 - Ensure that seals or sealing materials have not degraded such that they no longer serve the purpose of preventing the ingress of flammable atmospheres. Replacement parts shall be in accordance with the manufacturer's specifications.

NOTE: The use of silicon sealant may inhibit the effectiveness of some types of leak detection equipment. Intrinsically safe components do not have to be isolated prior to working on them.

2.11 Repair to intrinsically safe components

- Do not apply any permanent inductive or capacitance loads to the circuit without ensuring that this will not exceed the permissible voltage and current permitted for the equipment in use. Intrinsically safe components are the only types that can be worked on while live in the presence of a flammable atmosphere. The test apparatus shall be at the correct rating.
- Replace components only with parts specified by the manufacturer. Other parts may result in the ignition of refrigerant in the atmosphere from a leak.

2.12 Cabling

- Check that cabling will not be subject to wear, corrosion, excessive pressure, vibration, sharp edges or any other adverse environmental effects. The check

shall also take into account the effects of aging or continual vibration from sources such as compressors or fans.

2.13 Detection of flammable refrigerants

- Under no circumstances shall potential sources of ignition be used in the searching for or detection of refrigerant leaks. A halide torch (or any other detector using a naked flame) shall not be used.

Leak detection methods

- The following leak detection methods are deemed acceptable for systems containing flammable refrigerants. Electronic leak detectors shall be used to detect flammable refrigerants, but the sensitivity may not be adequate, or may need re-calibration. (Detection equipment shall be calibrated in a refrigerant-free area.) Ensure that the detector is not a potential source of ignition and is suitable for the refrigerant used. Leak detection equipment shall be set at a percentage of the LFL of the refrigerant and shall be calibrated to the refrigerant employed and the appropriate percentage of gas (25 % maximum) is confirmed. Leak detection fluids are suitable for use with most refrigerants but the use of detergents containing chlorine shall be avoided as the chlorine may react with the refrigerant and corrode the copper pipe-work.
 - If a leak is suspected, all naked flames shall be removed or extinguished.
 - If a leakage of refrigerant is found which requires brazing, all of the refrigerant shall be recovered from the system, or isolated (by means of shut off valves) in a part of the system remote from the leak. Oxygen free nitrogen (OFN) shall then be purged through the system both before and during the brazing process.

2.14 Removal and evacuation

- When breaking into the refrigerant circuit to make repairs or for any other purpose, conventional procedures shall be used. However, it is important that best practice is followed since flammability is a consideration.
- The following procedure shall be adhered to:
 - remove refrigerant;
 - purge the circuit with inert gas;
 - evacuate;
 - purge again with inert gas;
 - open the circuit by cutting or brazing.
- The refrigerant charge shall be recovered into the

correct recovery cylinders. The system shall be flushed with OFN to render the unit safe. This process may need to be repeated several times. Compressed air or oxygen shall not be used for this task. Flushing shall be achieved by breaking the vacuum in the system with OFN and continuing to fill until the working pressure is achieved, then venting to atmosphere, and finally pulling down to a vacuum. This process shall be repeated until no refrigerant is within the system. When the final OFN charge is used, the system shall be vented down to atmospheric pressure to enable work to take place. This operation is absolutely vital if brazing operations on the pipe-work are to take place.

- Ensure that the outlet for the vacuum pump is not close to any ignition sources and there is ventilation available.

2.15 Charging procedures

- In addition to conventional charging procedures, the following requirements shall be followed:
 - Ensure that contamination of different refrigerants does not occur when using charging equipment. Hoses or lines shall be as short as possible to minimize the amount of refrigerant contained in them.
 - Cylinders shall be kept upright.
 - Ensure that the refrigeration system is earthed prior to charging the system with refrigerant.
 - Label the system when charging is complete (if not already).
 - Extreme care shall be taken not to overfill the refrigeration system.
 - Prior to recharging the system it shall be pressure tested with OFN. The system shall be leak tested on completion of charging but prior to commissioning. A follow up leak test shall be carried out prior to leaving the site.

2.16 Decommissioning

Before carrying out this procedure, it is essential that the technician is completely familiar with the equipment and all its detail. It is recommended good practice that all refrigerants are recovered safely. Prior to the task being carried out, an oil and refrigerant sample shall be taken.

In case analysis is required prior to re-use of reclaimed refrigerant. It is essential that electrical power is available before the task is commenced.

- Become familiar with the equipment and its operation.
- Isolate system electrically.
- Before attempting the procedure ensure that:

- mechanical handling equipment is available, if required, for handling refrigerant cylinders;
- all personal protective equipment is available and being used correctly;
- the recovery process is supervised at all times by a competent person;
- recovery equipment and cylinders conform to the appropriate standards.
- Pump down refrigerant system, if possible.
- If a vacuum is not possible, make a manifold so that refrigerant can be removed from various parts of the system.
- Make sure that cylinder is situated on the scales before recovery takes place.
- Start the recovery machine and operate in accordance with manufacturer's instructions.
- Do not overfill cylinders. (No more than 80 % volume liquid charge).
- Do not exceed the maximum working pressure of the cylinder, even temporarily.
- When the cylinders have been filled correctly and the process completed, make sure that the cylinders and the equipment are removed from site promptly and all isolation valves on the equipment are closed off.
- Recovered refrigerant shall not be charged into another refrigeration system unless it has been cleaned and checked.

2.17 Labelling

- Equipment shall be labelled stating that it has been de-commissioned and emptied of refrigerant. The label shall be dated and signed. Ensure that there are labels on the equipment stating the equipment contains flammable refrigerant.

2.18 Recovery

- When removing refrigerant from a system, either for servicing or decommissioning, it is recommended good practice that all refrigerants are removed safely.
- When transferring refrigerant into cylinders, ensure that only appropriate refrigerant recovery cylinders are employed. Ensure that the correct numbers of cylinders for holding the total system charge are available. All cylinders to be used are designated for the recovered refrigerant and labelled for that refrigerant (i.e. special cylinders for the recovery of refrigerant). Cylinders shall be complete with pressure relief valve and associated shut-off valves in good working order. Empty recovery cylinders are evacuated and, if possible, cooled before recovery occurs.
- The recovery equipment shall be in good working

order with a set of instructions concerning the equipment that is at hand and shall be suitable for the recovery of flammable refrigerants. In addition, a set of calibrated weighing scales shall be available and in good working order.

- Hoses shall be complete with leak-free disconnect couplings and in good condition. Before using the recovery machine, check that it is in satisfactory working order, has been properly maintained and that any associated electrical components are sealed to prevent ignition in the event of a refrigerant release. Consult manufacturer if in doubt.
- The recovered refrigerant shall be returned to the refrigerant supplier in the correct recovery cylinder, and the relevant Waste Transfer Note arranged. Do not mix refrigerants in recovery units and especially not in cylinders.
- If compressors or compressor oils are to be removed, ensure that they have been evacuated to an acceptable level to make certain that flammable refrigerant does not remain within the lubricant. The evacuation process shall be carried out prior to returning the compressor to the suppliers. Only electric heating to the compressor body shall be employed to accelerate this process. When oil is drained from a system, it shall be carried out safely.

2.19 Venting of HC Refrigerant (R290)

Venting may be carried out as an alternative to recovering the refrigerant. Because HC refrigerants have no ODP and negligible GWP, under certain circumstances it may be considered acceptable to vent the refrigerant. However, if this is to be considered, it should be done in accordance with the relevant national rules or regulations, if they permit.

In particular, before venting a system, it would be necessary to:

- Ensure that legislation relating to waste material has been considered
- Ensure that environmental legislation has been considered
- Ensure that legislation addressing safety of hazardous substances is satisfied
- Venting is only carried out with systems that contain a small quantity of refrigerant, typically less than 500 g.
- Venting to inside a building is not permissible under any circumstances
- Venting must not be to a public area, or where people are unaware of the procedure taking place
- The hose must be of sufficient length and diameter such that it will extend to at least 3 m beyond the

outside of the building

- The venting should only take place on the certainty that the refrigerant will not get blown back into any adjacent buildings, and that it will not migrate to a location below ground level
- The hose is made of material that is compatible for use with HC refrigerants and oil
- A device is used to raise the hose discharge at least 1 m above ground level and so that the discharge is pointed in an upwards direction (to assist with dilution)
- The end of the hose can now discharge and disperse the flammable fumes into the ambient air.
- There should not be any restriction or sharp bends within the vent-line which will hinder the ease of flow.
- There must be no sources of ignition near the hose discharge
- The hose should be regularly checked to ensure that there are no holes or kinks in it, that could lead to leakage or blocking of the passage of flow

When carrying out the venting, the flow of refrigerant should be metered using manifold gauges to a low flow rate, so as to ensure the refrigerant is well diluted. Once the refrigerant has ceased flowing, if possible, the system should be flushed out with OFN; if not, then the system should be pressurised with OFN and the venting procedure carried out two or more times, to ensure that there is minimal HC refrigerant remaining inside the system.

2.20 Transportation, marking and storage for units

1. Transport of equipment containing flammable refrigerants

Compliance with the transport regulations

2. Marking of equipment using signs

Compliance with local regulations

3. Disposal of equipment using flammable refrigerants

Compliance with national regulations

4. Storage of equipment/appliances

The storage of the appliance should be in accordance with the applicable regulations or instructions, whichever is more stringent.

5. Storage of packed (unsold) equipment

Storage package protection should be constructed such that mechanical damage to the equipment inside the package will not cause a leak of the refrigerant charge.

The maximum number of pieces of equipment permitted to be stored together will be determined by local regulations.

Model Reference

Contents

1.	Model Reference.....	2
2	External Appearance.....	3

1. Model Reference

Refer to the following table to determine the specific indoor and outdoor unit model number of your purchased equipment.

Indoor Unit Model		Outdoor Unit Model	Capacity (Btu/h)	Power Supply
AHU	AHU18-SG2	CPR18CD(O)	18k	1Ph, 208/230V~, 60Hz
		CPH18CD(O)		
	AHU24-SG2	CPR24CD(O)	24k	
		CPH24CD(O)		
	AHU30-SG2	CPR30CD(O)	30k	
		CPH30CD(O)		
	AHU36-SG2	CPR36CD(O)	36k	
		CPH36CD(O)		
	AHU48-SG2	CPR48CD(O)	48k	
		CPH48CD(O)		
	AHU60-SG2	CPR60CD(O)	60k	
		CPH60CD(O)		

2. External Appearance

2.1 Indoor Unit

Air handler



2.2 Outdoor Unit

Single Fan Outdoor Unit



Double Fan Outdoor Unit



Indoor Unit-Air Handler

Contents

1.	Feature.....	2
2.	Dimensional Drawings	3
3.	Part names	4
4.	Service Place.....	4
5.	Accessories	5
6	Fan Performance	6
7.	Noise Criterion Curves.....	17
8.	Electrical Characteristics.....	19
9.	Electrical Wiring Diagrams.....	21

1. Feature

1.1 Full Multi-position installation

- This AHU is capable of upflow, downflow, horizontal left, or horizontal right configurations.

1.2 Installation Convenience

- It simplifies the airflow volume adjustment process and saves lots of installation efforts. The traditional adjustment method needs the installers to manually set the motor speed, according to the installation instruction and ducting design. It takes lots of time if this thing doesn't go well and decreases the marginal profits.

1.3 Easy Fault Code Checking

- Thanks to advanced mutual data communication technology, the AHU system can intelligently self-detecting the failure cause and generate a corresponding code.
- Installer or user can easily check the fault code displayed on the electric function board by just opening the lid.
- It helps you proactively determine the failure cause, prepare for repairing parts ahead of field maintenance work, greatly improve the work efficiency.

1.4 Nitrogen Charge and Leakage Check Valve

- Comfortstar AHU indoor unit is standard with Nitrogen injection to maintain positive pressure of the indoor unit. It is easy to check from the check valve whether there is leakage in the evaporator or not.

1.5 Automatic Airflow Adjustment

- During the operation, when the dust filter or evaporator is clogged with dust, the load of the system and motor torque increases. The MPU(microprocessor) on the unit can detect this change and adjust the fan speed to keep the CFM stable.

2. Dimensional Drawings

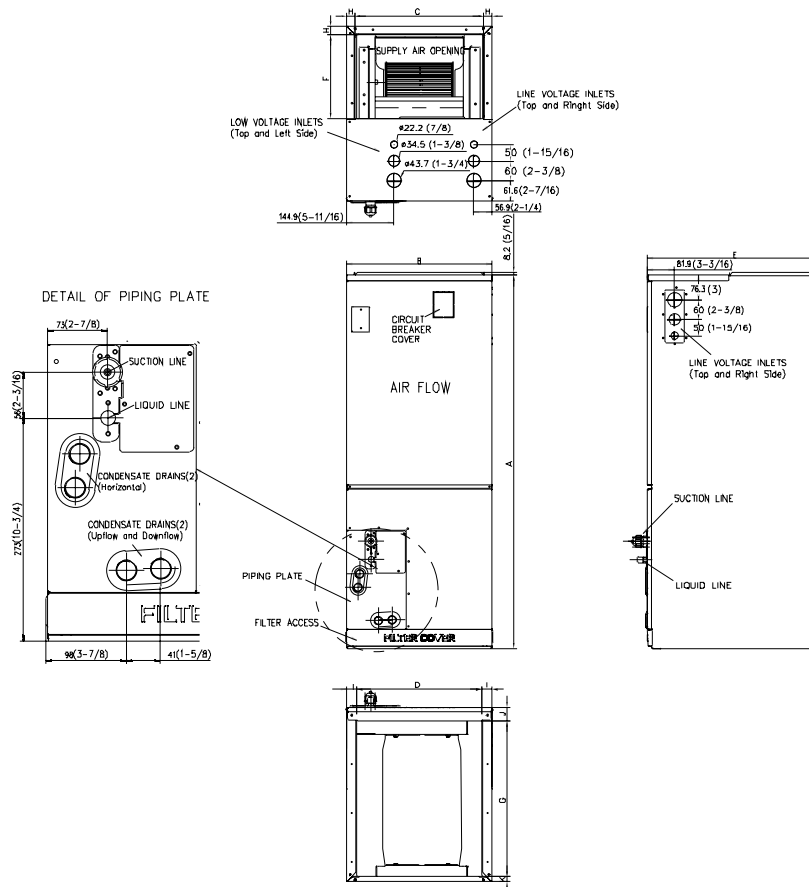

Dimensions		Model	18k/24k		30k/36/48k		60k	
			inch	mm	inch	mm	inch	mm
A	Model Height		45	1143	49	1245	53	1346
B	Model Width		17-1/2	445	21	534	24-1/2	622
C	Supply Air Opening Width		15-5/8	397	19-1/8	486	22-5/8	575
D	Return Air Opening Width		15-1/8	384	18-5/8	473	22-1/8	562
E	Model Depth		21	534	21	534	21	534
F	Supply Air Opening Depth		10-1/4	260	10-1/4	260	10-1/4	260
G	Return Air Opening Depth		18-3/4	476	18-3/4	476	18-3/4	476
H	Supply Air Opening Clearance		15/16	24	15/16	24	15/16	24
I	Return Air Opening Side Clearance		1-1/4	32	1-1/4	32	1-1/8	28
J	Return Air Opening Front Clearance		1-1/2	38	1-5/8	41	1-5/8	41
K	Return Air Opening Back Clearance		5/8	16	5/8	16	3/4	19

3. Part names

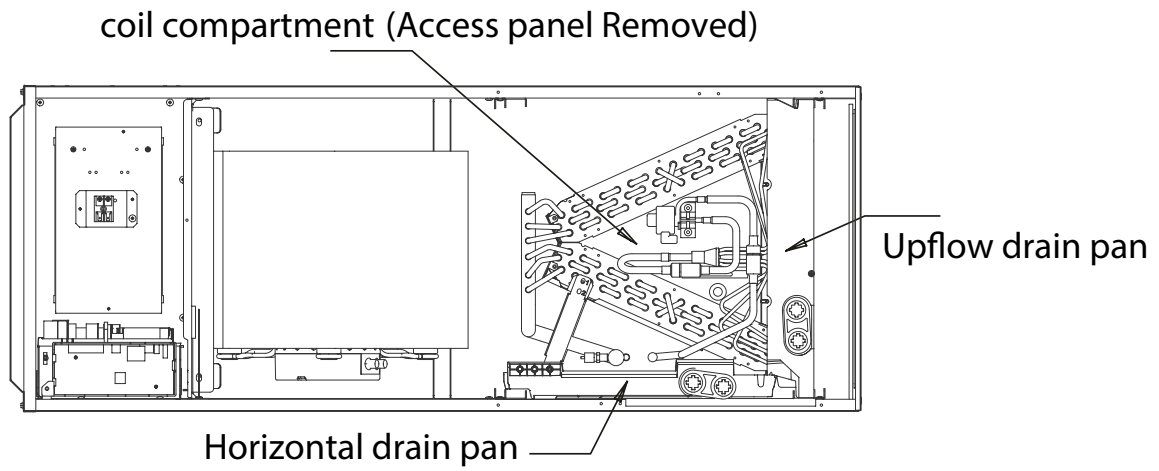



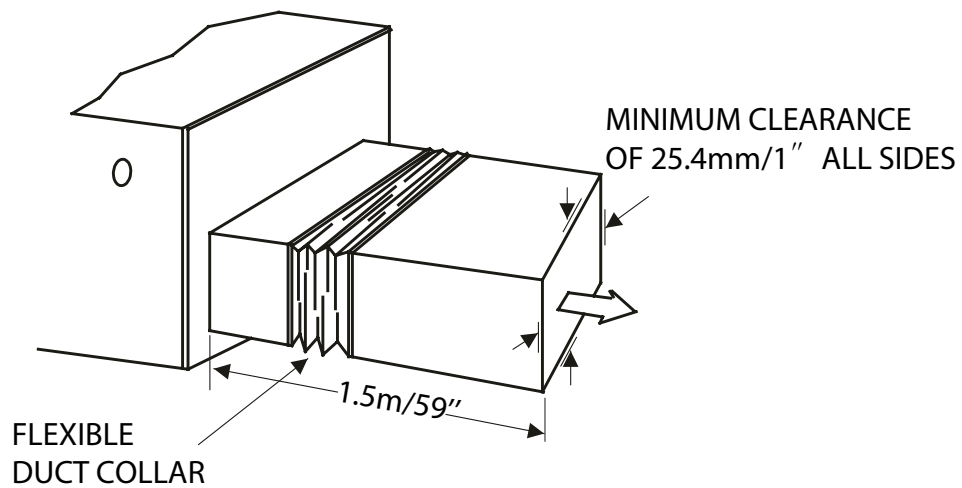





4. Service Place

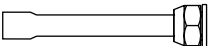
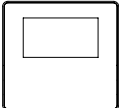



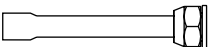

5. Accessories

The air conditioning system comes with the following accessories. Use all of the installation parts and accessories to install the air conditioner. Improper installation may result in water leakage, electrical shock and fire, or equipment failure.

Name	Shape	Quantity	
Manual		3	
Remote controller		1	
Battery		2	
Transfer connector		2	
Wired remote controller		1	
Fasten belt		2	
Sponge		4	
Flare nut		2	
Packed with the outdoor unit	Drain joint		1
	Seal		1
	Transfer connector		2

Note: The remote control is only used to adjust the parameters.

Installation of Electric Auxiliary Heat Module (for some models) (not supplied)

Name	Shape	Quantity
Owner's manual & Installation manual		2
Seal sponge		1
Screw		7
Rubber cap		1
Electric auxiliary heating wiring diagram	/	1
Air switch label	/	1

6. Fan Performance

6.1 AHU18-SG2

Vertical, Horizontal Right, Horizontal Left

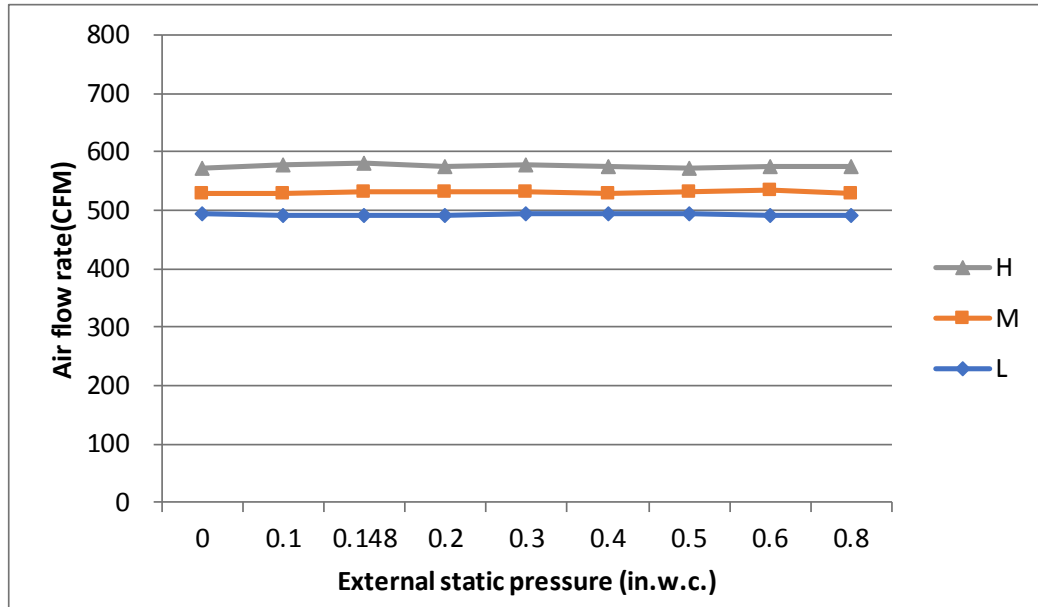

Use the remote controller

1. Indoor unit need to turn off for 5 minutes then power on(all of setting need to finish within 10 minutes)
2. Keep push for 7 seconds with ON/OFF and FAN SPEED togther to get in Engineer mode
3. Choose channel 23(for cooling) and 25(for heating) with UP and Down button
4. After choose channel 23 or 25 then keep push ON/OFF for 2 seconds to select -41, -40,....., -1, 0, 1,2,3.....19 20(reference the matrix list to identify the relative CFM)
5. Push the button OK to confirm the adjustment value,the display board will display with CS mean success(for setting),then disconnect power after 5 seconds

Cooling	Default	-1	-2	-3	-4	-5	-6	-7
Turbo	618	598	578	558	538	518	498	478
High	576	556	536	516	496	476	456	436
Medium	529	509	489	469	449	429	418	418
Low	488	468	448	428	408	400	400	400
Cooling	Default	-8	-9 ~ -40	+1	+2	+3	+4	+5 ~ +20
Turbo	618	458	453	635	635	635	635	635
High	576	435	435	596	616	618	618	618
Medium	529	418	418	549	569	589	600	600
Low	488	400	400	508	528	548	568	582

Heating	Default	-1	-2	-3	-4	-5	-6 ~ -40	+1	+2
Turbo	565	545	525	505	485	465	453	585	605
High	541	521	501	481	461	441	435	561	581
Medium	435	418	418	418	418	418	418	455	475
Low	400	400	400	400	400	400	400	420	440
Heating	Default	+3	+4	+5	+6	+7	+8	+9	+10~+20
Turbo	565	625	635	635	635	635	635	635	635
High	541	601	618	618	618	618	618	618	618
Medium	435	495	515	535	555	575	595	600	600
Low	400	460	480	500	520	540	560	580	582

6.2 AHU24-SG2

Vertical, Horizontal Right, Horizontal Left

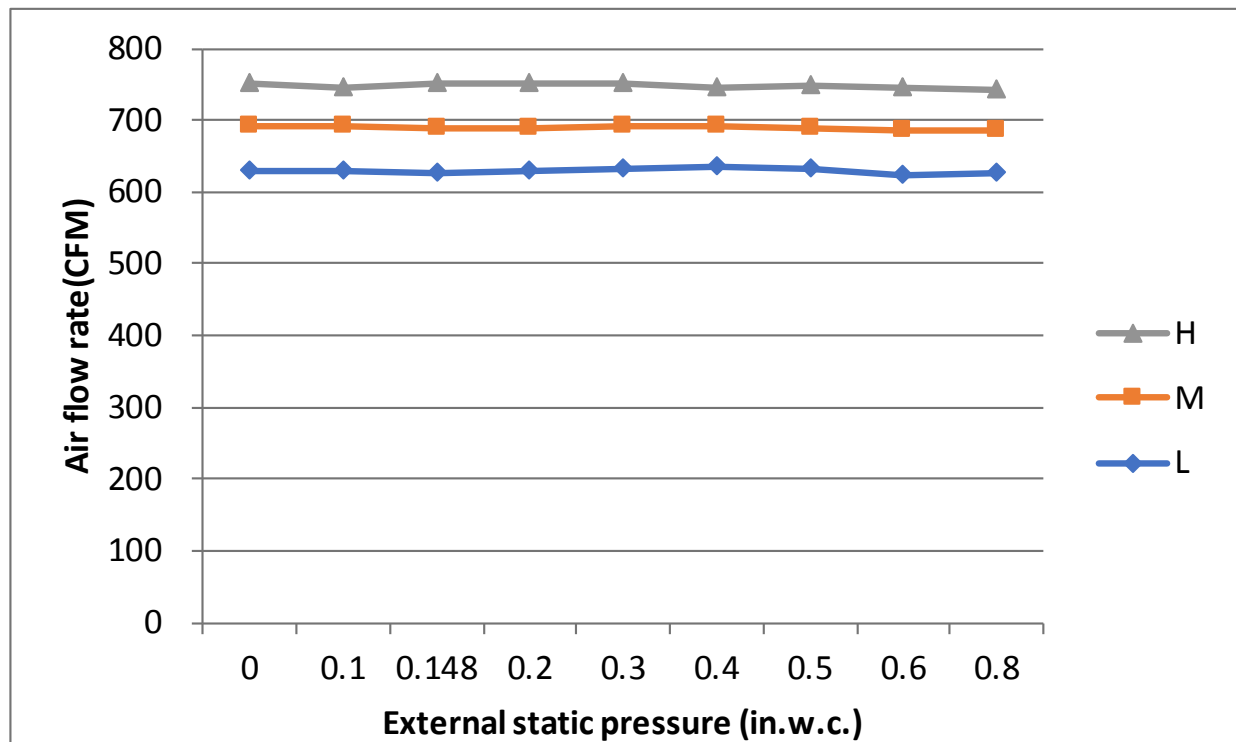

Use the remote controller

1. Indoor unit need to turn off for 5 minutes then power on(all of setting need to finish within 10 minutes)
2. Keep push for 7 seconds with ON/OFF and FAN SPEED together to get in Engineer mode
3. Choose channel 23(for cooling) and 25(for heating) with UP and Down button
4. After choose channel 23 or 25 then keep push ON/OFF for 2 seconds to select -41, -40,....., -1, 0, 1,2,3.....19 20(reference the matrix list to identify the relative CFM)
5. Push the button OK to confirm the adjustment value,the display board will display with CS mean success(for setting),then disconnect power after 5 seconds

Cooling	Default	-1	-2	-3	-4	-5	-6	-7	-8	-9	-10
Turbo	988	804	784	764	744	724	704	684	664	644	624
High	894	739	719	699	679	659	639	619	599	579	559
Medium	806	674	654	634	614	594	574	554	534	514	494
Low	712	609	589	569	549	529	509	489	469	449	429
Cooling	Default	-11	-12	-13	-14	-15	-16	-17	-18	-19~-40	+1
Turbo	988	604	584	564	544	524	504	484	464	453	844
High	894	539	519	499	479	459	439	435	435	435	779
Medium	806	474	454	434	418	418	418	418	418	418	714
Low	712	409	400	400	400	400	400	400	400	400	649
Cooling	Default	+2	+3	+4	+5	+6	+7	+8	+9~+20		
Turbo	988	853	853	853	853	853	853	853	853		
High	894	799	819	835	835	835	835	835	835		
Medium	806	734	754	774	794	814	818	818	818		
Low	712	669	689	709	729	749	769	789	800		

Heating	Default	-1	-2	-3	-4	-5	-6	-7	-8	-9	-10	-11
Turbo	788	768	748	728	708	688	668	648	628	608	588	568
High	753	733	713	693	673	653	633	613	593	573	553	533
Medium	641	621	601	581	561	541	521	501	481	461	441	421
Low	524	504	484	464	444	424	404	400	400	400	400	400
Heating	Default	-12	-13	-14	-15	-16	-17~-40	+1	+2	+3	+4	+5
Turbo	788	548	528	508	488	468	453	808	828	848	853	853
High	753	513	493	473	453	435	435	773	793	813	833	835
Medium	641	418	418	418	418	418	418	661	681	701	721	741
Low	524	400	400	400	400	400	400	544	564	584	604	624
Heating	Default	+6	+7	+8	+9	+10	+11	+12	+13	+14~+20		
Turbo	788	853	853	853	853	853	853	853	853	853		
High	753	835	835	835	835	835	835	835	835	835		
Medium	641	761	781	801	818	818	818	818	818	818		
Low	524	644	664	684	704	724	744	764	784	800		

6.3 AHU30-SG2

Vertical, Horizontal Right, Horizontal Left

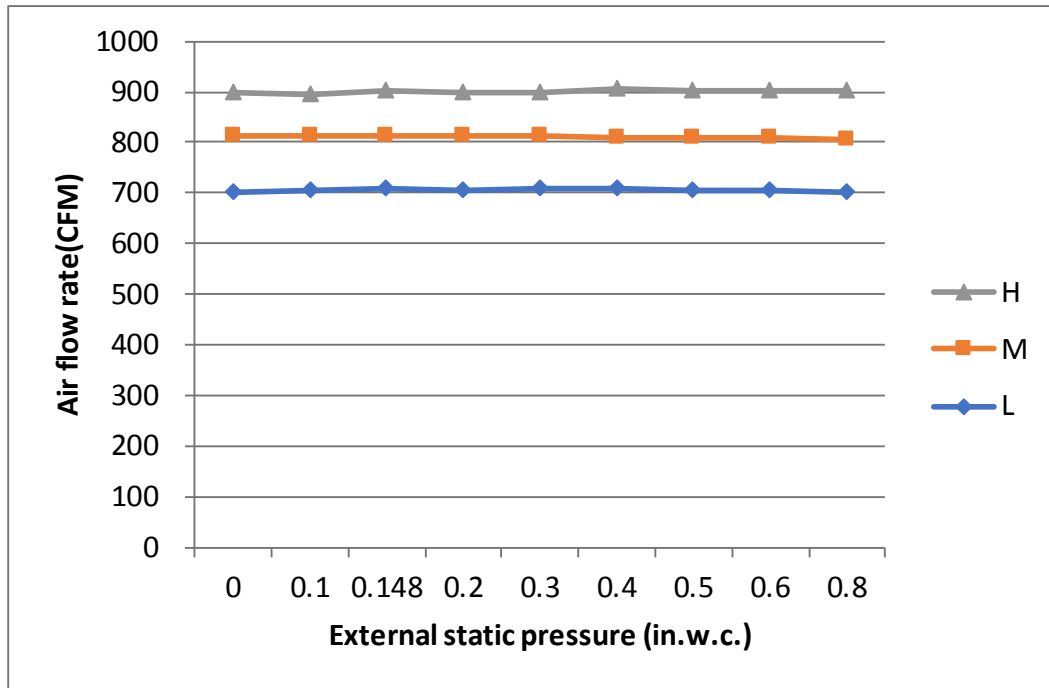

Use the remote controller

1. Indoor unit need to turn off for 5 minutes then power on(all of setting need to finish within 10 minutes)
2. Keep push for 7 seconds with ON/OFF and FAN SPEED togher to get in Engineer mode
3. Choose channel 23(for cooling) and 25(for heating) with UP and Down button
4. After choose channel 23 or 25 then keep push ON/OFF for 2 seconds to select -41, -40,....., -1, 0, 1,2,3.....19 20(reference the matrix list to identify the relative CFM)
5. Push the button OK to confirm the adjustment value,the display board will display with CS mean success(for setting),then disconnect power after 5 seconds

Cooling	Default	-1	-2	-3	-4	-5	-6	-7	-8	-9	-10	-11
Turbo	988	968	948	928	908	888	868	848	828	808	788	768
High	894	874	854	834	814	794	774	754	734	714	694	674
Medium	806	786	766	746	726	706	686	666	646	626	606	586
Low	712	692	672	652	632	612	592	572	552	532	512	492
Cooling	Default	-12	-13	-14	-15	-16	-17	-18	-19	-20	-21	-22
Turbo	988	748	728	708	688	668	648	628	608	588	568	548
High	894	654	634	614	594	574	554	534	514	494	474	454
Medium	806	566	546	526	506	486	466	446	426	418	418	418
Low	712	472	452	432	412	400	400	400	400	400	400	400
Cooling	Default	-23	-24	-25	-26	+1	+2	+3	+4	+5	+6	+7
Turbo	988	528	508	488	468	988	1008	1028	1048	1068	1071	1071
High	894	435	435	435	435	894	914	934	954	974	994	1014
Medium	806	418	418	418	418	806	826	846	866	886	906	926
Low	712	400	400	400	400	712	732	752	772	792	812	832
Cooling	Default	+8	+9	+10	+11	+12	+13	+14	+15	+16	+17~+20	
Turbo	988	1071	1071	1071	1071	1071	1071	1071	1071	1071	1071	
High	894	1034	1053	1053	1053	1053	1053	1053	1053	1053	1053	
Medium	806	946	966	986	1006	1026	1035	1035	1035	1035	1035	
Low	712	852	872	892	912	932	952	972	992	1012	1018	

Heating	Default	-1	-2	-3	-4	-5	-6	-7	-8	-9	-10
Turbo	918	898	878	858	838	818	798	778	758	738	718
High	876	856	836	816	796	776	756	736	716	696	676
Medium	665	645	625	605	585	565	545	525	505	485	465
Low	453	433	413	400	400	400	400	400	400	400	400
Heating	Default	-11	-12	-13	-14	-15	-16	-17	-18	-19	-20
Turbo	918	698	678	658	638	618	598	578	558	538	518
High	876	656	636	616	596	576	556	536	516	496	476
Medium	665	445	425	418	418	418	418	418	418	418	418
Low	453	400	400	400	400	400	400	400	400	400	400
Heating	Default	-21	-22	-23	-24~-40	+1	+2	+3	+4	+5	+6
Turbo	918	498	478	458	453	938	958	978	998	1018	1038
High	876	456	436	435	435	896	916	936	956	976	996
Medium	665	418	418	418	418	685	705	725	745	765	785
Low	453	400	400	400	400	473	493	513	533	553	573
Heating	Default	+7	+8	+9	+10	+11	+12	+13	+14~+20		
Turbo	918	1058	1071	1071	1071	1071	1071	1071	1071		
High	876	1016	1036	1053	1053	1053	1053	1053	1053		
Medium	665	805	825	845	865	885	905	925	945		
Low	453	593	613	633	653	673	693	713	733		

6.4 AHU36-SG2

Vertical, Horizontal Right, Horizontal Left

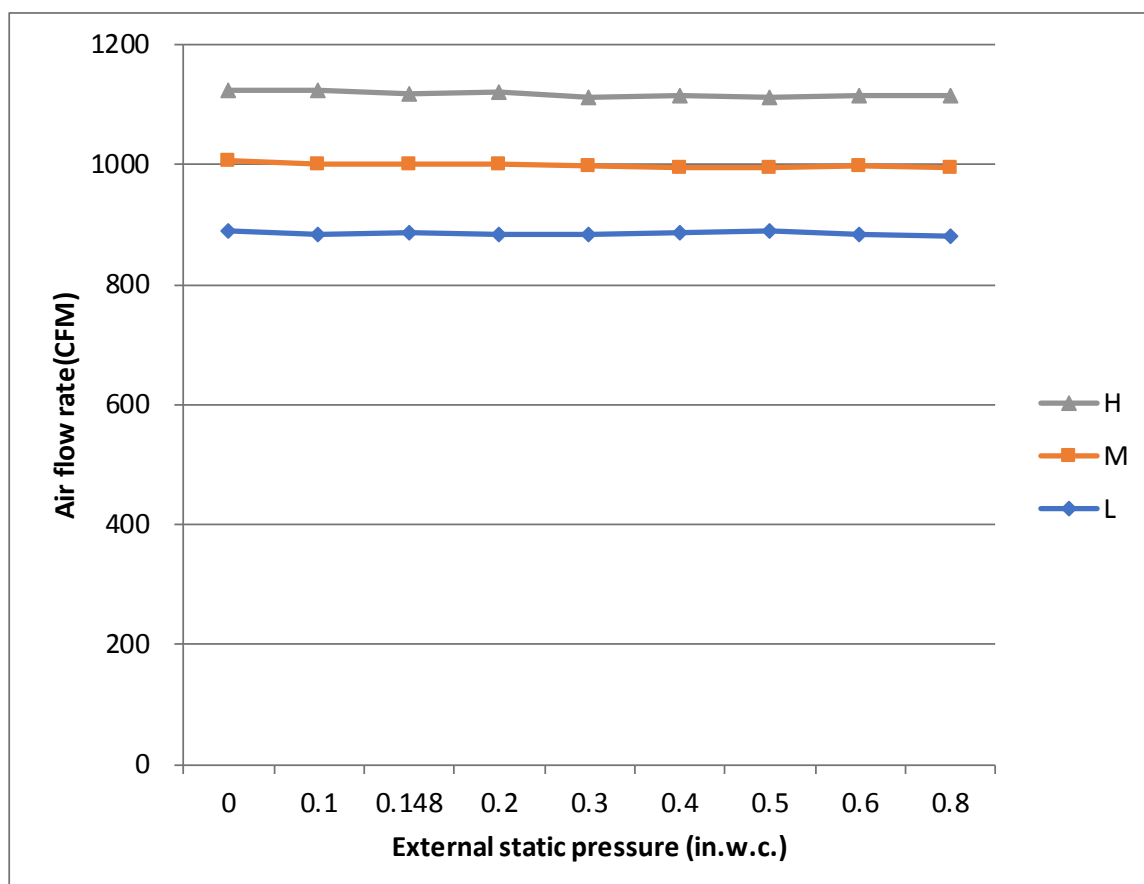

Use the remote controller

1. Indoor unit need to turn off for 5 minutes then power on(all of setting need to finish within 10 minutes)
2. Keep push for 7 seconds with ON/OFF and FAN SPEED together to get in Engineer mode
3. Choose channel 23(for cooling) and 25(for heating) with UP and Down button
4. After choose channel 23 or 25 then keep push ON/OFF for 2 seconds to select -41, -40,....., -1, 0, 1,2,3.....19 20(reference the matrix list to identify the relative CFM)
5. Push the button OK to confirm the adjustment value,the display board will display with CS mean success(for setting),then disconnect power after 5 seconds

Cooling	Default	-1	-2	-3	-4	-5	-6	-7	-8	-9	-10	-11	-12
Turbo	1188	1168	1148	1128	1108	1088	1068	1048	1028	1008	988	968	948
High	1082	1062	1042	1022	1002	982	962	942	922	902	882	862	842
Medium	971	951	931	911	891	871	851	831	811	791	771	751	731
Low	865	845	825	805	785	765	745	725	705	685	665	645	625
Cooling	Default	-13	-14	-15	-16	-17	-18	-19	-20	-21	-22	-23	-24
Turbo	1188	928	908	888	868	848	828	808	788	768	748	728	708
High	1082	822	802	782	762	742	722	702	682	662	642	622	602
Medium	971	711	691	671	651	631	611	591	571	551	531	511	491
Low	865	605	585	565	545	525	505	485	465	445	425	405	400
Cooling	Default	-25	-26	-27	-28	-29	-30	-31	-32	-33	-34	-35	-36
Turbo	1188	688	668	648	628	608	588	568	548	528	508	488	468
High	1082	582	562	542	522	502	482	462	442	435	435	435	435
Medium	971	471	451	431	418	418	418	418	418	418	418	418	418
Low	865	400	400	400	400	400	400	400	400	400	400	400	400

Cooling	Default	-37~-40	+1	+2	+3	+4	+5	+6	+7	+8	+9	+10	+11
Turbo	1188	453	1208	1228	1248	1268	1288	1288	1288	1288	1288	1288	1288
High	1082	435	1102	1122	1142	1162	1182	1202	1222	1242	1262	1271	1271
Medium	971	418	991	1011	1031	1051	1071	1091	1111	1131	1151	1171	1191
Low	865	400	885	905	925	945	965	985	1005	1025	1045	1065	1085
Cooling	Default	+12	+13	+14	+15	+16	+17	+18	+19~+20				
Turbo	1188	1288	1288	1288	1288	1288	1288	1288	1288				
High	1082	1271	1271	1271	1271	1271	1271	1271	1271				
Medium	971	1211	1231	1251	1253	1253	1253	1253	1253				
Low	865	1105	1125	1145	1165	1185	1205	1225	1235				

Heating	Default	-1	-2	-3	-4	-5	-6	-7	-8	-9	-10	-11
Turbo	1112	1092	1072	1052	1032	1012	992	972	952	932	912	892
High	1059	1039	1019	999	979	959	939	919	899	879	859	839
Medium	794	774	754	734	714	694	674	654	634	614	594	574
Low	582	562	542	522	502	482	462	442	422	402	400	400
Heating	Default	-12	-13	-14	-15	-16	-17	-18	-19	-20	-21	-22
Turbo	1112	872	852	832	812	792	772	752	732	712	692	672
High	1059	819	799	779	759	739	719	699	679	659	639	619
Medium	794	554	534	514	494	474	454	434	418	418	418	418
Low	582	400	400	400	400	400	400	400	400	400	400	400
Heating	Default	-23	-24	-25	-26	-27	-28	-29	-30	-31	-32	-33~-40
Turbo	1112	652	632	612	592	572	552	532	512	492	472	453
High	1059	599	579	559	539	519	499	479	459	439	435	435
Medium	794	418	418	418	418	418	418	418	418	418	418	418
Low	582	400	400	400	400	400	400	400	400	400	400	400
Heating	Default	+1	+2	+3	+4	+5	+6	+7	+8	+9	+10	+11
Turbo	1112	1132	1152	1172	1192	1212	1232	1252	1272	1288	1288	1288
High	1059	1079	1099	1119	1139	1159	1179	1199	1219	1239	1259	1271
Medium	794	814	834	854	874	894	914	934	954	974	994	1014
Low	582	602	622	642	662	682	702	722	742	762	782	802
Heating	Default	+12	+13	+14	+15	+16	+17	+18	+19	+20		
Turbo	1112	1288	1288	1288	1288	1288	1288	1288	1288	1288		
High	1059	1271	1271	1271	1271	1271	1271	1271	1271	1271		
Medium	794	1034	1054	1074	1094	1114	1134	1154	1174	1194		
Low	582	822	842	862	882	902	922	942	962	982		

6.5 AHU48-SG2

Vertical, Horizontal Right, Horizontal Left

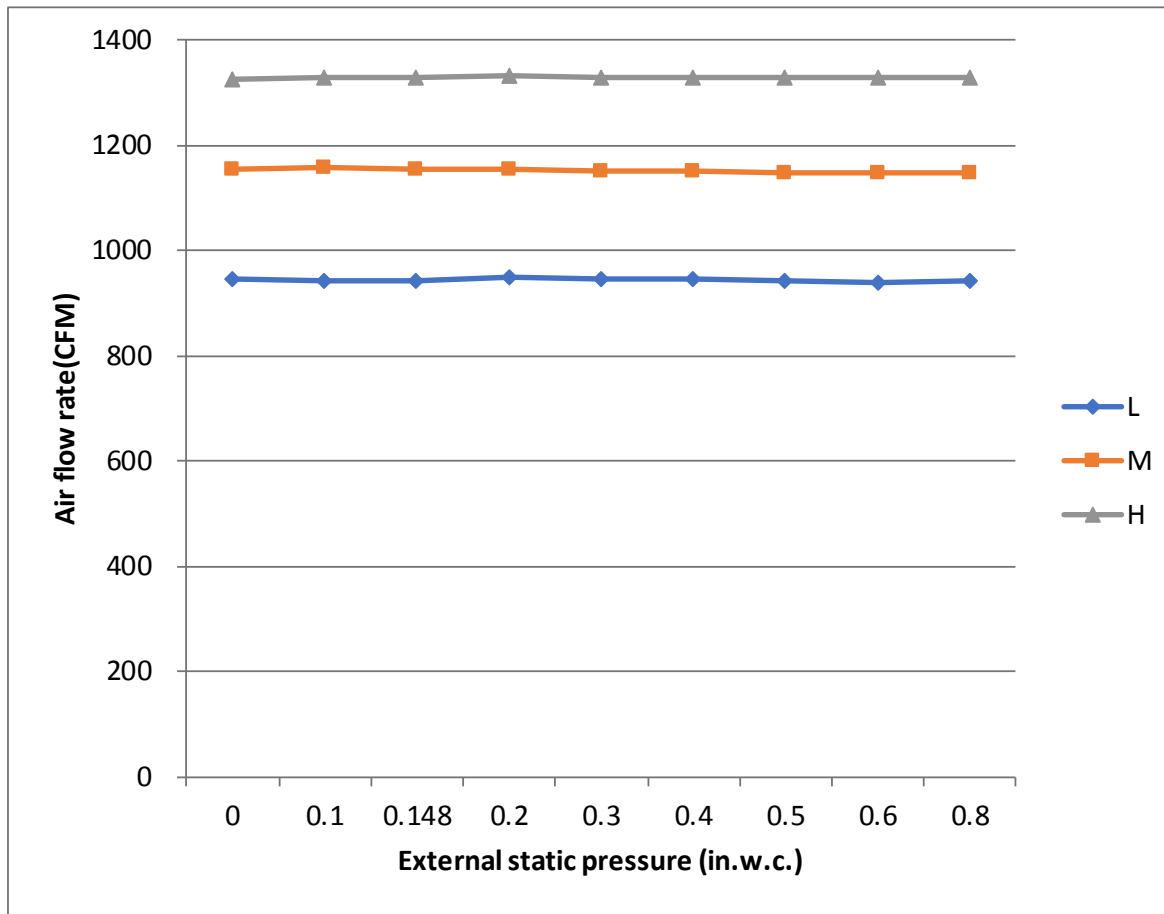

Use the remote controller

1. Indoor unit need to turn off for 5 minutes then power on(all of setting need to finish within 10 minutes)
2. Keep push for 7 seconds with ON/OFF and FAN SPEED together to get in Engineer mode
3. Choose channel 23(for cooling) and 25(for heating) with UP and Down button
4. After choose channel 23 or 25 then keep push ON/OFF for 2 seconds to select -41, -40,....., -1, 0, 1,2,3.....19 20(reference the matrix list to identify the relative CFM)
5. Push the button OK to confirm the adjustment value,the display board will display with CS mean success(for setting),then disconnect power after 5 seconds

Cooling	Default	-1	-2	-3	-4	-5	-6	-7	-8	-9	-10
Turbo	1471	1451	1431	1411	1391	1371	1351	1331	1311	1291	1271
High	1282	1262	1242	1222	1202	1182	1162	1142	1122	1102	1082
Medium	1094	1074	1054	1034	1014	994	974	954	934	914	894
Low	906	886	866	846	826	806	786	766	746	726	706
Cooling	Default	-11	-12	-13	-14	-15	-16	-17	-18	-19	-20
Turbo	1471	1251	1231	1211	1191	1171	1151	1131	1111	1091	1071
High	1282	1062	1042	1022	1002	982	962	942	922	902	882
Medium	1094	874	854	834	814	794	774	754	734	714	694
Low	906	686	666	646	626	606	586	566	546	526	506
Cooling	Default	-21	-22	-23	-24	-25	-26	-27	-28	-29	-30
Turbo	1471	1051	1031	1011	991	971	951	931	911	891	871
High	1282	862	842	822	802	782	762	742	722	702	682
Medium	1094	674	654	634	614	594	574	554	534	514	494
Low	906	486	466	465	465	465	465	465	465	465	465

Cooling	Default	-31	-32	-33	-34	-35	-36	-37	-38	-39	-40
Turbo	1471	851	831	811	791	771	751	731	711	691	671
High	1282	662	642	622	602	582	562	542	522	502	500
Medium	1094	482	482	482	482	482	482	482	482	482	482
Low	906	465	465	465	465	465	465	465	465	465	465
Cooling	Default	+1	+2	+3	+4	+5	+6	+7	+8	+9	+10
Turbo	1471	1491	1511	1531	1551	1571	1591	1611	1631	1651	1671
High	1282	1302	1322	1342	1362	1382	1402	1422	1442	1462	1482
Medium	1094	1114	1134	1154	1174	1194	1214	1234	1254	1274	1294
Low	906	926	946	966	986	1006	1026	1046	1066	1086	1106
Cooling	Default	+11	+12	+13	+14	+15	+16	+17	+18	+19	+20
Turbo	1471	1691	1711	1724	1724	1724	1724	1724	1724	1724	1724
High	1282	1502	1522	1542	1562	1582	1602	1622	1642	1662	1682
Medium	1094	1314	1334	1354	1374	1394	1414	1434	1454	1474	1494
Low	906	1126	1146	1166	1186	1206	1226	1246	1266	1286	1306

Heating	Default	-1	-2	-3	-4	-5	-6	-7	-8	-9	-10
Turbo	1471	1451	1431	1411	1391	1371	1351	1331	1311	1291	1271
High	1306	1286	1266	1246	1226	1206	1186	1166	1146	1126	1106
Medium	1141	1121	1101	1081	1061	1041	1021	1001	981	961	941
Low	976	956	936	916	896	876	856	836	816	796	776
Heating	Default	-11	-12	-13	-14	-15	-16	-17	-18	-19	-20
Turbo	1471	1251	1231	1211	1191	1171	1151	1131	1111	1091	1071
High	1306	1086	1066	1046	1026	1006	986	966	946	926	906
Medium	1141	921	901	881	861	841	821	801	781	761	741
Low	976	756	736	716	696	676	656	636	616	596	576
Heating	Default	-21	-22	-23	-24	-25	-26	-27	-28	-29	-30
Turbo	1471	1051	1031	1011	991	971	951	931	911	891	871
High	1306	886	866	846	826	806	786	766	746	726	706
Medium	1141	721	701	681	661	641	621	601	581	561	541
Low	976	556	536	516	496	476	465	465	465	465	465
Heating	Default	-31	-32	-33	-34	-35	-36	-37	-38	-39	-40
Turbo	1471	851	831	811	791	771	751	731	711	691	671
High	1306	686	666	646	626	606	586	566	546	526	506
Medium	1141	521	501	482	482	482	482	482	482	482	482
Low	976	465	465	465	465	465	465	465	465	465	465
Heating	Default	+1	+2	+3	+4	+5	+6	+7	+8	+9	+10
Turbo	1471	1491	1511	1531	1551	1571	1591	1611	1631	1651	1671
High	1306	1326	1346	1366	1386	1406	1426	1446	1466	1486	1506
Medium	1141	1161	1181	1201	1221	1241	1261	1281	1301	1321	1341
Low	976	996	1016	1036	1056	1076	1096	1116	1136	1156	1176
Heating	Default	+11	+12	+13	+14	+15	+16	+17	+18	+19	+20
Turbo	1471	1691	1711	1724	1724	1724	1724	1724	1724	1724	1724
High	1306	1526	1546	1566	1586	1606	1626	1646	1666	1686	1706
Medium	1141	1361	1381	1401	1421	1441	1461	1481	1501	1521	1541
Low	976	1196	1216	1236	1256	1276	1296	1316	1336	1356	1376

6.6 AHU60-SG2

Vertical, Horizontal Right, Horizontal Left

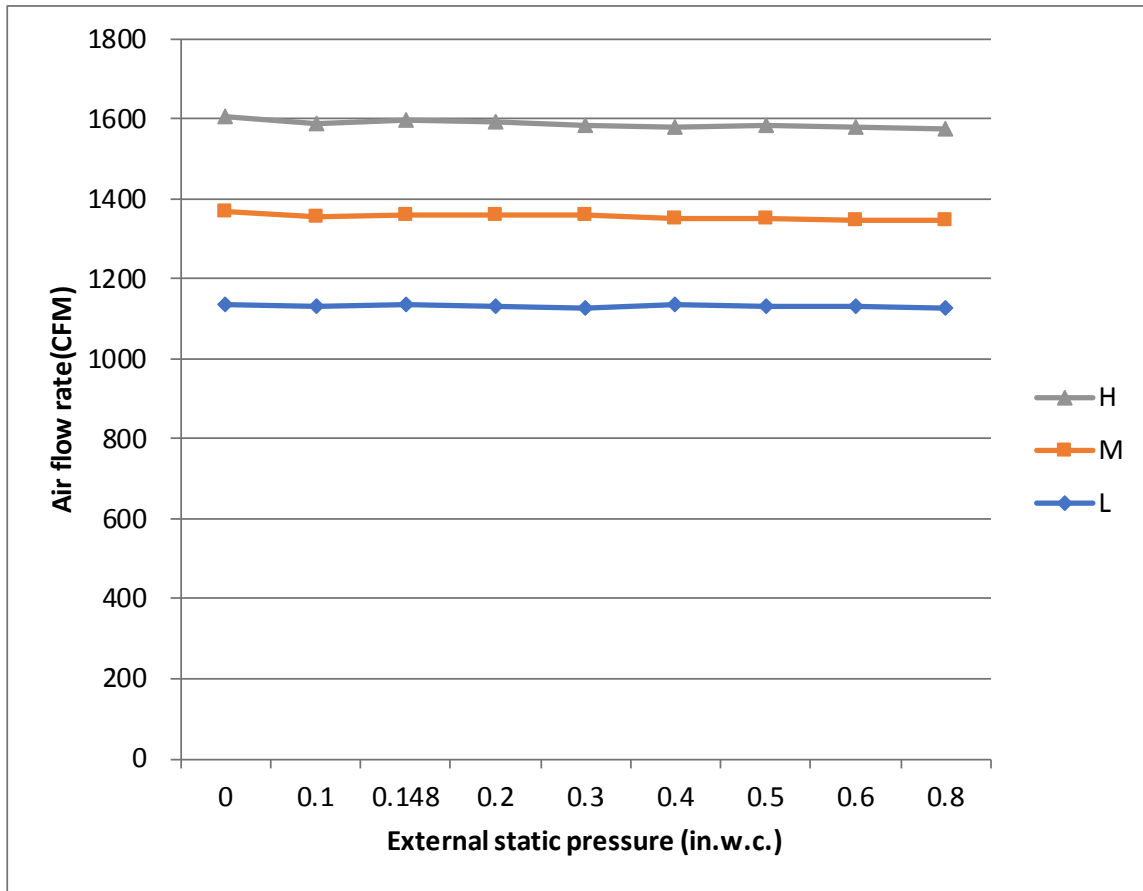

Use the remote controller

1. Indoor unit need to turn off for 5 minutes then power on (all of setting need to finish within 10 minutes)
2. Keep push for 7 seconds with ON/OFF and FAN SPEED together to get in Engineer mode
3. Choose channel 23 (for cooling) and 25 (for heating) with UP and Down button
4. After choose channel 23 or 25 then keep push ON/OFF for 2 seconds to select -41, -40, ..., -1, 0, 1, 2, 3, ..., 19, 20 (reference the matrix list to identify the relative CFM)
5. Push the button OK to confirm the adjustment value, the display board will display with CS mean success (for setting), then disconnect power after 5 seconds

Cooling	Default	-1	-2	-3	-4	-5	-6	-7	-8	-9	-10
Turbo	1806	1786	1766	1746	1726	1706	1686	1666	1646	1626	1606
High	1582	1562	1542	1522	1502	1482	1462	1442	1422	1402	1382
Medium	1359	1339	1319	1299	1279	1259	1239	1219	1199	1179	1159
Low	1135	1115	1095	1075	1055	1035	1015	995	975	955	935
Cooling	Default	-11	-12	-13	-14	-15	-16	-17	-18	-19	-20
Turbo	1806	1586	1566	1546	1526	1506	1486	1466	1446	1426	1406
High	1582	1362	1342	1322	1302	1282	1262	1242	1222	1202	1182
Medium	1359	1139	1119	1099	1079	1059	1039	1019	999	979	959
Low	1135	915	895	875	855	835	815	795	775	755	735
Cooling	Default	-21	-22	-23	-24	-25	-26	-27	-28	-29	-30
Turbo	1806	1386	1366	1346	1326	1306	1286	1266	1246	1226	1206
High	1582	1162	1142	1122	1102	1082	1062	1042	1022	1002	982
Medium	1359	939	919	899	879	859	839	819	799	779	759
Low	1135	715	695	694	694	694	694	694	694	694	694

Cooling	Default	-31	-32	-33	-34	-35	-36	-37	-38	-39	-40
Turbo	1806	1186	1166	1146	1126	1106	1086	1066	1046	1026	1006
High	1582	962	942	922	902	882	862	842	822	802	782
Medium	1359	739	719	712	712	712	712	712	712	712	712
Low	1135	694	694	694	694	694	694	694	694	694	694
Cooling	Default	+1	+2	+3	+4	+5	+6	+7	+8	+9	+10
Turbo	1806	1826	1846	1866	1886	1906	1926	1946	1966	1986	2006
High	1582	1602	1622	1642	1662	1682	1702	1722	1742	1762	1782
Medium	1359	1379	1399	1419	1439	1459	1479	1499	1519	1539	1559
Low	1135	1155	1175	1195	1215	1235	1255	1275	1295	1315	1335
Cooling	Default	+11	+12	+13	+14	+15	+16	+17	+18	+19	+20
Turbo	1806	2026	2046	2066	2086	2106	2126	2146	2153	2153	2153
High	1582	1802	1822	1842	1862	1882	1902	1922	1942	1962	1982
Medium	1359	1579	1599	1619	1639	1659	1679	1699	1719	1739	1759
Low	1135	1355	1375	1395	1415	1435	1455	1475	1495	1515	1535

Heating	Default	-1	-2	-3	-4	-5	-6	-7	-8	-9	-10
Turbo	1659	1639	1619	1599	1579	1559	1539	1519	1499	1479	1459
High	1582	1562	1542	1522	1502	1482	1462	1442	1422	1402	1382
Medium	1247	1227	1207	1187	1167	1147	1127	1107	1087	1067	1047
Low	976	956	936	916	896	876	856	836	816	796	776
Heating	Default	-11	-12	-13	-14	-15	-16	-17	-18	-19	-20
Turbo	1659	1439	1419	1399	1379	1359	1339	1319	1299	1279	1259
High	1582	1362	1342	1322	1302	1282	1262	1242	1222	1202	1182
Medium	1247	1027	1007	987	967	947	927	907	887	867	847
Low	976	756	736	716	696	694	694	694	694	694	694
Heating	Default	-21	-22	-23	-24	-25	-26	-27	-28	-29	-30
Turbo	1659	1239	1219	1199	1179	1159	1139	1119	1099	1079	1059
High	1582	1162	1142	1122	1102	1082	1062	1042	1022	1002	982
Medium	1247	827	807	787	767	747	727	712	712	712	712
Low	976	694	694	694	694	694	694	694	694	694	694
Heating	Default	-31	-32	-33	-34	-35	-36	-37	-38	-39	-40
Turbo	1659	1039	1019	999	979	959	939	919	899	879	859
High	1582	962	942	922	902	882	862	842	822	802	782
Medium	1247	712	712	712	712	712	712	712	712	712	712
Low	976	694	694	694	694	694	694	694	694	694	694
Heating	Default	+1	+2	+3	+4	+5	+6	+7	+8	+9	+10
Turbo	1659	1679	1699	1719	1739	1759	1779	1799	1819	1839	1859
High	1582	1602	1622	1642	1662	1682	1702	1722	1742	1762	1782
Medium	1247	1267	1287	1307	1327	1347	1367	1387	1407	1427	1447
Low	976	996	1016	1036	1056	1076	1096	1116	1136	1156	1176
Heating	Default	+11	+12	+13	+14	+15	+16	+17	+18	+19	+20
Turbo	1659	1879	1899	1919	1939	1959	1979	1999	2019	2039	2059
High	1582	1802	1822	1842	1862	1882	1902	1922	1942	1962	1982
Medium	1247	1467	1487	1507	1527	1547	1567	1587	1607	1627	1647
Low	976	1196	1216	1236	1256	1276	1296	1316	1336	1356	1376

7. Noise Criterion Curves

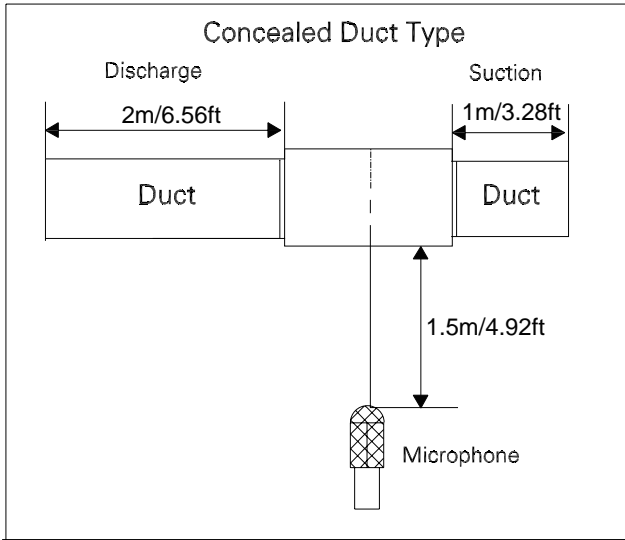

Horizontal installation

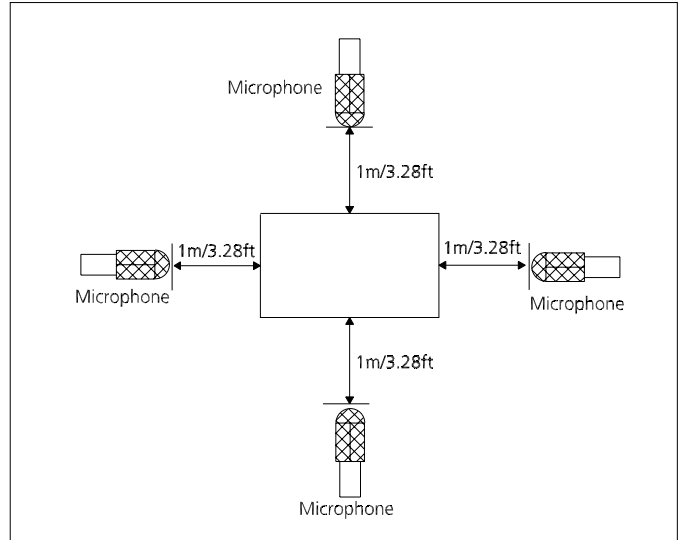

Vertical installation

$$(H = 0.5 \times (\text{height of unit} + 1))$$

Notes:

- Sound measured at 1.5m/4.92ft(Horizontal installation) /1m/3.28ft(Vertical installation) away from the center of the unit.
- Data is valid at free field condition
- Data is valid at nominal operation condition
- Reference acoustic pressure $OdB = 20\mu Pa$
- Sound level will vary depending on a range of factors such as the construction -(acoustic absorption coefficient) of particular room in which the equipment is installed.
- The operating conditions are assumed to be standard.

AHU18-SG2

AHU24-SG2

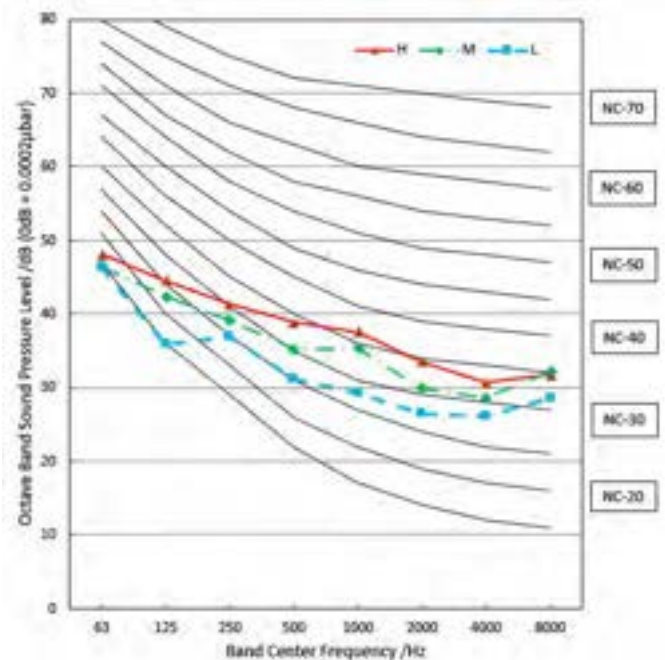
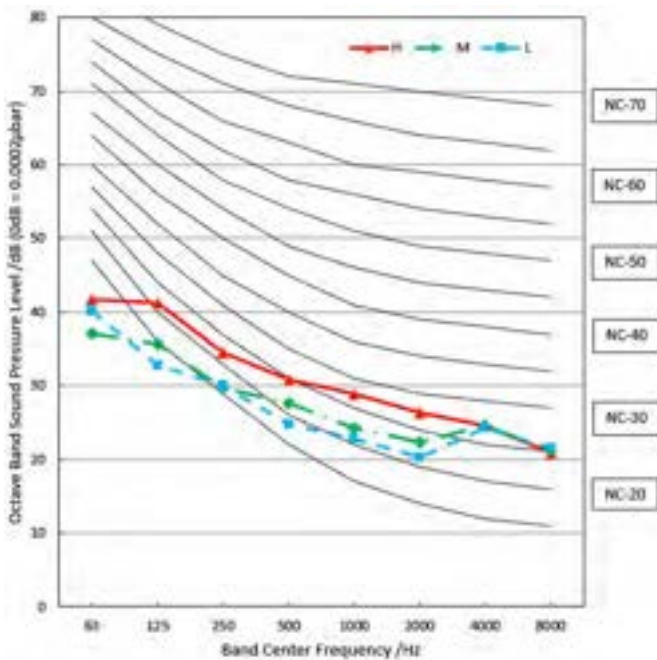

AHU30-SG2

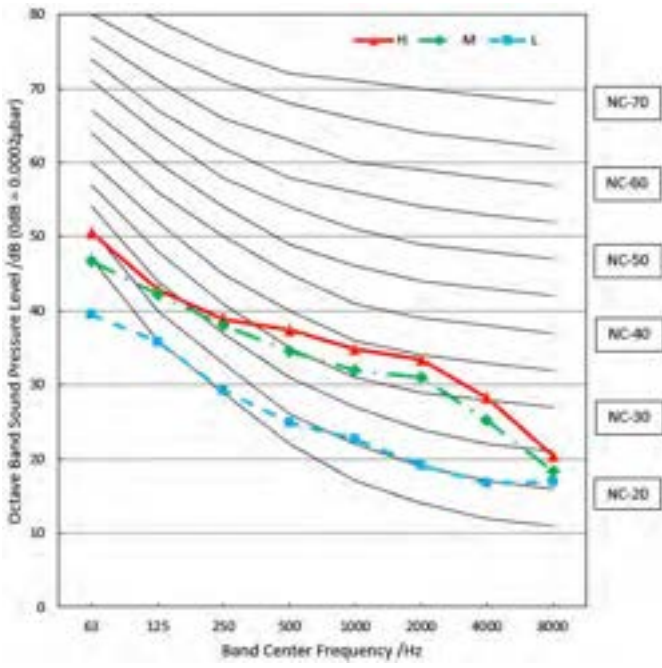

AHU36-SG2

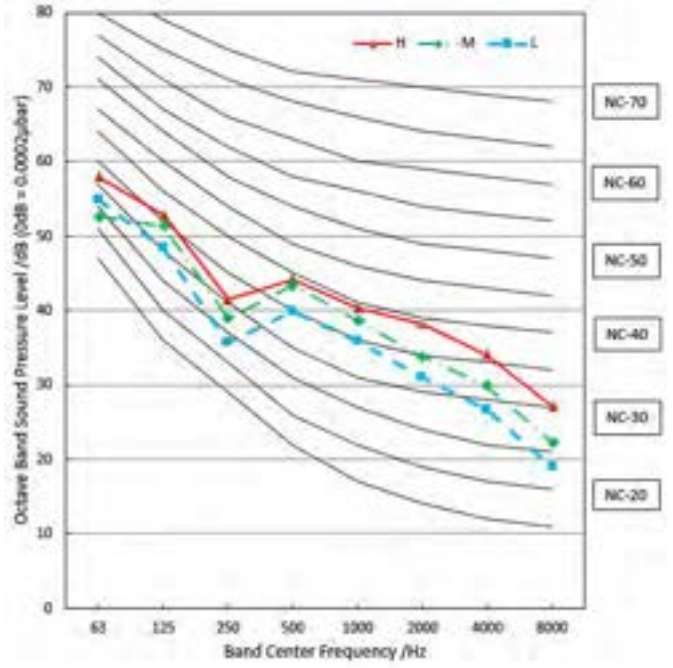

AHU48-SG2

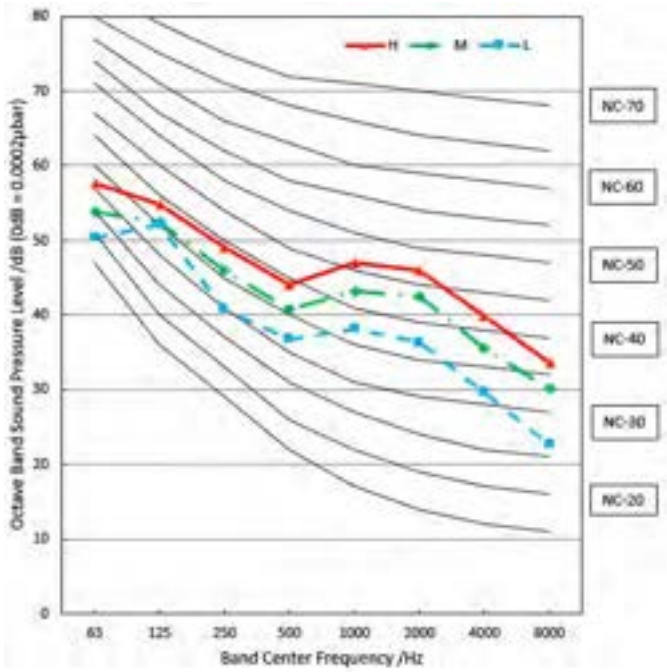

AHU60-SG2

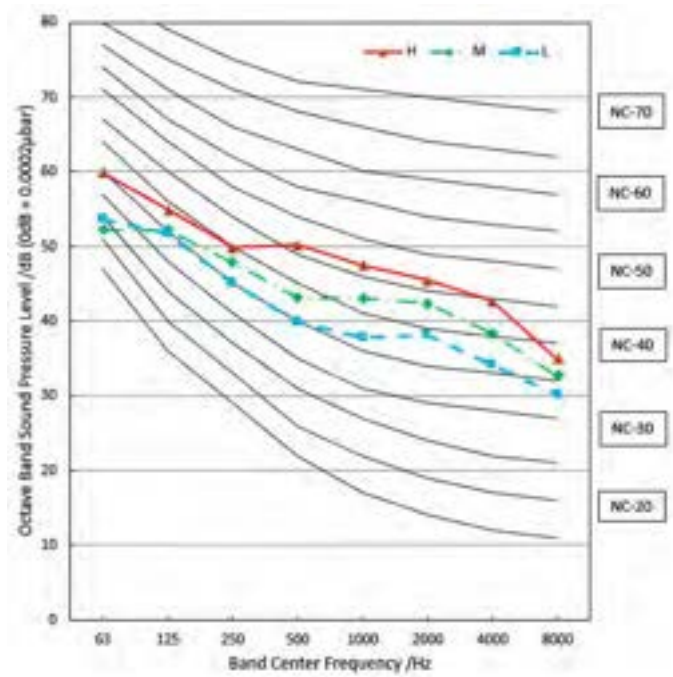

8. Electrical Characteristics

Capacity (Btu/h)		18k	24k	30k
Power (indoor)	Phase	1	1	1
	Frequency And Volt	208/230V,60Hz		
Power (Outdoor)	Phase	1	1	1
	Frequency And Volt	208/230V,60Hz		
Max. Fuse	Indoor unit(A)	15	15	15
	Outdoor unit(A)	20	30	35
Indoor unit Power line	Line quantity	3	3	3
	Line diameter(AWG)	16/1.5mm ²	16/1.5mm ²	16/1.5mm ²
Outdoor unit Power line	Line quantity	3	3	3
	Line diameter(AWG)	14/2.5mm ²	12/4.0mm ²	12/4.0mm ²
Outdoor-indoor Signal line	Line quantity	2	2	2
	Line diameter(AWG)	20/0.5mm ²	20/0.5mm ²	20/0.5mm ²
Thermostat Signal line	Line quantity	/		
	Line diameter(AWG)	18/1.0mm ²	18/1.0mm ²	18/1.0mm ²

Capacity (Btu/h)		36k	48k	60k
Power (indoor)	Phase	1	1	1
	Frequency And Volt	208/230V,60Hz		
Power (Outdoor)	Phase	1	1	1
	Frequency And Volt	208/230V,60Hz		
Max. Fuse	Indoor unit(A)	15	15	15
	Outdoor unit(A)	40	50	60
Indoor unit Power line	Line quantity	3	3	3
	Line diameter(AWG)	16/1.5mm ²	16/1.5mm ²	16/1.5mm ²
Outdoor unit Power line	Line quantity	3	3	3
	Line diameter(AWG)	12/4.0mm ²	10/6.0mm ²	10/6.0mm ²
Outdoor-indoor Signal line	Line quantity	2	2	2
	Line diameter(AWG)	20/0.5mm ²	20/0.5mm ²	20/0.5mm ²
Thermostat Signal line	Line quantity	/		
	Line diameter(AWG)	18/1.0mm ²	18/1.0mm ²	18/1.0mm ²

Capacity (Btu/h)		18k hyper Heat	24k hyper Heat	30k hyper Heat
Power (indoor)	Phase	1	1	1
	Frequency And Volt	208/230V,60Hz		
Power (Outdoor)	Phase	1	1	1
	Frequency And Volt	208/230V,60Hz		
Max. Fuse	Indoor unit(A)	15	15	15
	Outdoor unit(A)	20	35	35
Indoor unit Power line	Line quantity	3	3	3
	Line diameter(AWG)	16/1.5mm ²	16/1.5mm ²	16/1.5mm ²
Outdoor unit Power line	Line quantity	3	3	3
	Line diameter(AWG)	12/4.0mm ²	12/4.0mm ²	12/4.0mm ²
Outdoor-indoor Signal line	Line quantity	2	2	2
	Line diameter(AWG)	20/0.5mm ²	20/0.5mm ²	20/0.5mm ²
Thermostat Signal line	Line quantity			
	Line diameter(AWG)	18/1.0mm ²	18/1.0mm ²	18/1.0mm ²

Capacity (Btu/h)		36k hyper Heat*1	36k hyper Heat*2	48k hyper Heat	60k hyper Heat
Power (indoor)	Phase	1	1	1	1
	Frequency And Volt	208/230V,60Hz			
Power (Outdoor)	Phase	1	1	1	1
	Frequency And Volt	208/230V,60Hz			
Max. Fuse	Indoor unit(A)	15	15	15	15
	Outdoor unit(A)	35	50	50	60
Indoor unit Power line	Line quantity	3	3	3	3
	Line diameter(AWG)	16/1.5mm ²	16/1.5mm ²	16/1.5mm ²	16/1.5mm ²
Outdoor unit Power line	Line quantity	3	3	3	3
	Line diameter(AWG)	10/6.0mm ²	8/8.0mm ²	8/8.0mm ²	8/8.0mm ²
Outdoor-indoor Signal line	Line quantity	2	2	2	2
	Line diameter(AWG)	20/0.5mm ²	20/0.5mm ²	20/0.5mm ²	20/0.5mm ²
Thermostat Signal line	Line quantity				
	Line diameter(AWG)	18/1.0mm ²	18/1.0mm ²	18/1.0mm ²	18/1.0mm ²

36k hyper Heat*2 is match with CPH36CD(O).

9. Electrical Wiring Diagrams

IDU Capacity (Btu/h)	IDU Wiring Diagram
18k~60k	16023000013937

Abbreviation	Paraphrase
Y/G	Yellow-Green Conductor
CAP	Indoor Fan Capacitor
FAN	Indoor Fan Motor
ECM	Indoor ECM Motor
TO CCM Comm.Bus	Central Controller
T1	Indoor Room Temperature Sensor
T2A	Indoor Coil Inlet Temperature Sensor
T2B	Indoor Coil Outlet Temperature Sensor
T2	Indoor Coil Temperature Sensor

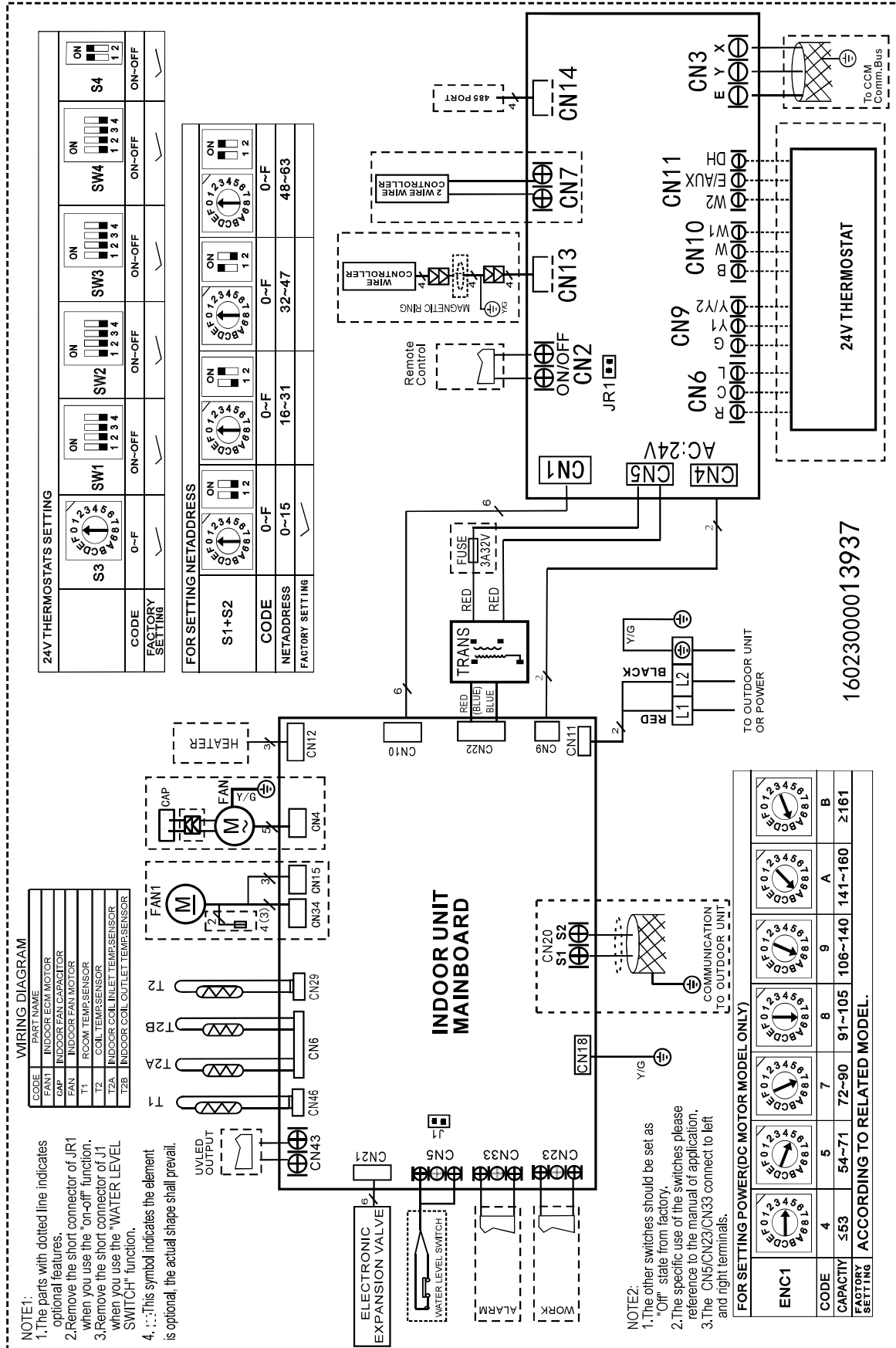

10.1 Micro-Switch Introduce:

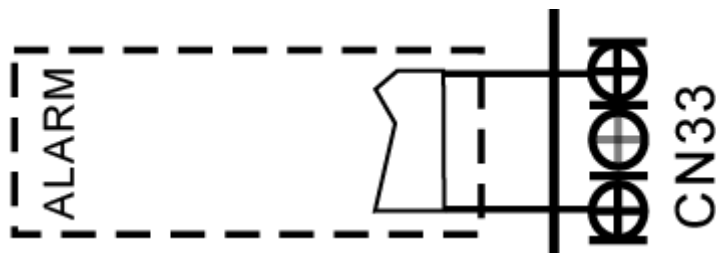

A For ALARM terminal port CN33

1. Provide the terminal port to connect ALARM, but no voltage of the terminal port , the power from the ALARM system (not from the unit)
2. Although design voltage can support higher voltage ,but we strongly ask you connect the power less than 24V, current less than 0.5A
3. When the unit occurs the problem , the relay would be closed , then ALARM works

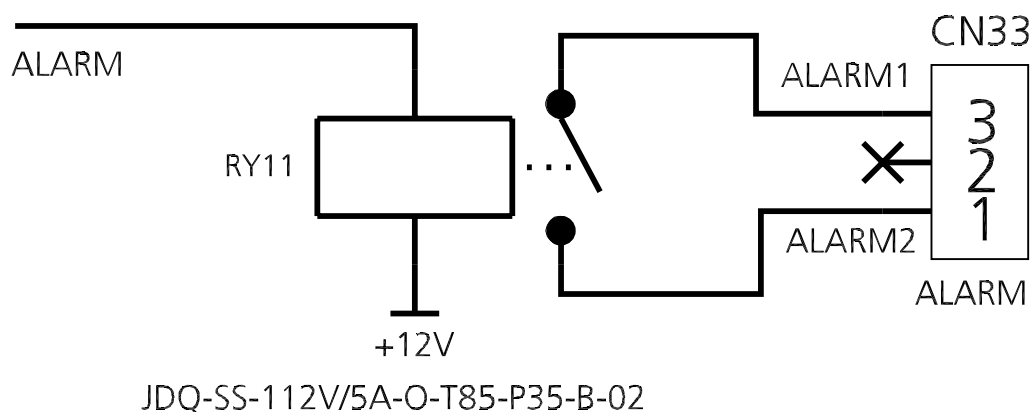

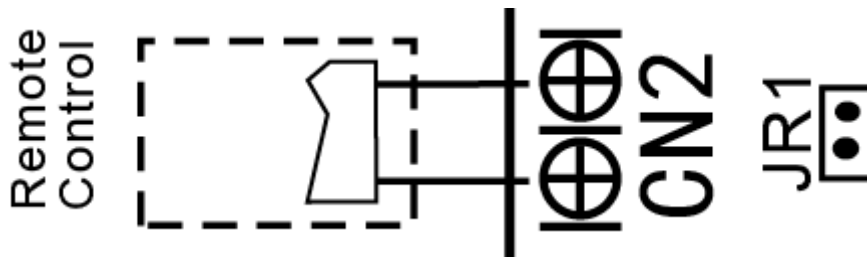

B. For remote control (ON-OFF) terminal port CN2 and short connector of JR1

1. Remove the short connector of JR1 when you use ON-OFF function;
2. When remote switch off (OPEN); the unit would be off;
3. When remote switch on (CLOSE); the unit would be on;
4. When close/open the remote switch, the unit would be responded the demand within 2 seconds;
5. When the remote switch on, you can use remote controller/ wire controller to select the mode what you want; when the remote switch off, the unit would not respond the demand from remote controller/wire controller. when the remote switch off, but the remote controller/wire controller are on, CP code would be shown on the display board.
6. The voltage of the port is 12V DC, design Max. current is 5mA.

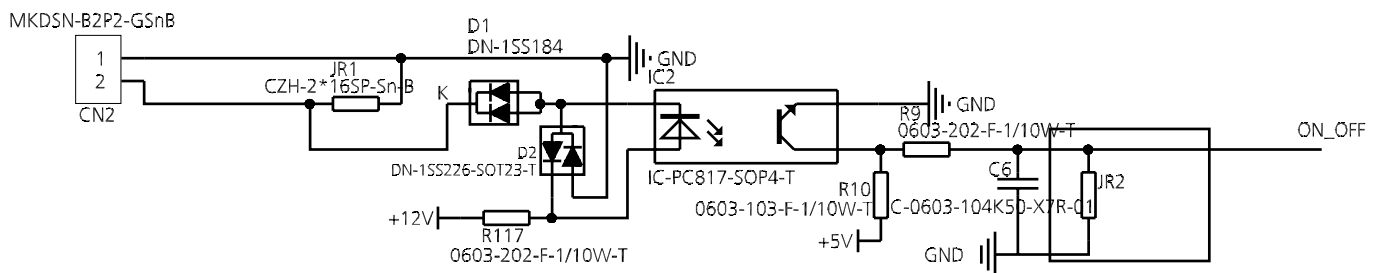

10.2 Micro-Switch Introduce:

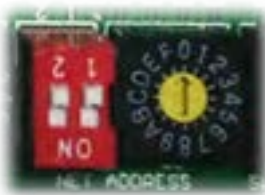

FOR SETTING NETADDRESS				
S1+S2				
CODE	0~F	0~F	0~F	0~F
NETADDRESS	0~15	16~31	32~47	48~63
FACTORY SETTING	✓			

A. Micro-switch S1 and dial-switch S2 are for address setting when you want to control this unit by a central controller.

Range: 00-63

Network address: The address silkscreen is NET address, which is composed of a 16-bit address rotary code S2 plus a two-digit DIP switch S1 [Set during engineering installation, no network function does not need to be set]

When S2 is 00 (the dialing code is not connected), the network address value is the value of S2;

When S2 is 10 (corresponding to the switch of the hardware connected to the 10K resistor), the network address value is S2 plus 32;

Determined by dial code S2 1-10K 2-5.1K

When S2 is 01 (corresponding to the dial code of the 5.1K resistor connected to the hardware is turned on), the network address value is the value of S2 plus 16;

When S2 is 11 (all dialing codes are on), the network address value is the value of S2 plus 48.

Dial code selection	Website address
	S2+48
	S2+32
	S2+16
	S2



FOR SETTING POWER(DC MOTOR MODEL ONLY)							
ENC1							
CODE	4	5	7	8	9	A	B
POWER	≤53	54~71	72~90	91~105	106~140	141~160	≥161
FACTORY SETTING	ACCORDING TO RELATED MODEL.						

B. Dial-switch ENC1: The indoor PCB is universal designed for whole series units from 7K to 68K. This ENC1 setting will tell the main program what size the unit is.

NOTE: Usually there is glue on it because the switch position cannot be changed at random unless you want to use this PCB as a spare part to use in another unit. Then you have to select the right position to match the size of the unit.

“53” means 5.3kW (18K), “105” means 10.5kW(36K), and so on.



24V THERMOSTATS SETTING						
CODE	0~F	ON-OFF	ON-OFF	ON-OFF	ON-OFF	ON-OFF
FACTORY SETTING	✓	✓	✓	✓	✓	✓

C. Function DIP Switch Settings

No.	Dial code	Control Scenario	Function	ON	OFF(Default)	
1	SW1-2	1,2,3	Anti-cold blow protection option	No	[Default] Yes	
2	SW1-3	1,2,3	Single cooling / heating and cooling options	Cooling	[Default] Cooling & Heating	
3	SW2-1	1	Compressor Running (demand working with heat pump+ Electric heat)	Compressor slower speed	[Default] Faster Compressor	Only affects compressor and W1
4	SW2-1	2	Temperature differential to activate first stage auxiliary heat(the GAP of T1 and Ts),Wire controller demand with heat pump+Electric heat working together	2°F(1°C)	[Default] 4°F(2°C)	
5	SW2-2	2	Electric heat on delay	Yes	[Default] No	
6	SW2-3	2	Electric auxiliary heating delay to start time	30 minutes	[Default] 15 minutes	Based on SW2-2 is ON

7	SW2-4	1	Compressor	The operation of heat pump is limited by the outdoor temperature, and the operation of auxiliary heat is not limited. The system makes judgments according to the following rules:1) The compressor can be operated when the outdoor temperature is \geq S3 DIP switch temperature +2 °C. 2) The compressor cannot be operated when the outdoor temperature is lower than the S3 DIP switch temperature.	[Default] The operation of heat pump is limited by the outdoor temperature, and the operation of auxiliary heat is not limited. The system makes judgments based on the following rules:1) The compressor cannot be operated when the outdoor temperature is lower than the S3 DIP switch. 2) The compressor can be operated when the outdoor temperature is \geq S3 DIP switch temperature +2 °C.	SW2-4 and S3 need to working together
8	SW2-4	2	Compressor/Auxiliary heat outdoor ambient lockout	The operation of heat pump is limited by the outdoor temperature, and the operation of auxiliary heat is not limited. The system makes judgments according to the following rules:1) The compressor can be operated when the outdoor temperature is \geq S3 DIP switch temperature +2 °C. 2) The compressor cannot be operated when the outdoor temperature is lower than the S3 DIP switch temperature.	[Default] Only one heat pump or auxiliary heat can be operated .The system makes judgments according to the following rules:1) When the outdoor temperature is lower than the S3 DIP switch temperature,the compressor is not allowed to operated, but auxiliary heat is allowed to operated; 2) When the outdoor temperature is \geq S3 DIP switch temperature +2(°C), the compressor can be operated, but auxiliary heat cannot be operated.	
9	Rotary Switch S3	1,2	Set outdoor temperature Limitation (for auxiliary heating or compressor)	Table A		
10	SW3-1	1	Maximum continuous runtime allowed before system automatically stages up capacity to satisfy set point. This adds 1 to 5°F to the user set point in the calculated control point to increase capacity and satisfy user set point	30 minutes	[Default] 90 minutes	
11	SW3-2	1	Cooling and heating Y/ Y2 temperature differential adjustment.	Compressor slower speed	[Default] Faster Compressor	Only affects compressor
12	SW3-3	1	Compressor Running (demand working with heat pump+ Electric heat)	Compressor slower speed	[Default] Faster Compressor	Only affects compressor and W2
13	SW3-3	2	Temperature differential to activate second stage auxiliary heating(the GAP of T1 and Ts)Wire controller demand with heat pump+Electric heat working together	4°F(2°C)	[Default] 6°F(3°C)	
14	SW3-4	1,3	Fan speed of cooling mode when 24V Thermostat is applied for.	Turbo	High	
15	SW4	1,2,3	Electric heat nominal CFM adjustment	Available settings are 000/001/010/011. Each digit corresponds an individual switch position. For example [SW4-1 OFF, SW4-2 ON, SW4 -3 OFF] = 010		

16	S4-1	1,3	Default ON	[Default] For single stage supplemental heat,W1 and W2 are connected	For dual stage supplemental heat, W1 and W2 are controlled independently.	
17	S4-2	1,3	DH function selection	[Default] Dehumidification control not available	Dehumidification feature is enabled through thermostat	

Control Scenario	24V Tstat, S1+S2	1
	Wired Controller S1+S2	2
	Full 24V	3



Table A

S3	S3 (°F)	S3(°C)
0	OFF	OFF
1	-22	-30
2	-18	-28
3	-15	-26
4	-11	-24
5	-8	-22
6	-4	-20
7	3	-16
8	10	-12
9	18	-8
A	25	-4
B	32	0
C	36	2
D	39	4
E	43	6
F	46	8

SW4-1	000 is the default 000/001/010/011/100/101/110/111, internal machines with different abilities, electric heating and PSC classification for use
SW4-2	
SW4-3	

NOTICE: The SW4 DIP switch is only for Certified service technicians to debug and use, please do not touch it.

Function combination table of SW1-1 and SW1-4

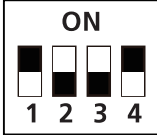
SW1	Control type	Stand alone or full system
	Free match	Free match
	Wired controller	Full system
	24V Thermostat	Full system
	24V Thermostat	Stand alone

Outdoor Unit

Contents

1.	Dimensional Drawings	2
2.	Service Place.....	19
3.	Capacity Correction Factor for Height Difference	20
4.	Noise Criterion Curves.....	25
5.	Refrigerant Cycle Diagrams	29
6.	Electrical Wiring Diagrams.....	35

1. Dimensional Drawings

Please check the corresponding dimensional drawing according to the panel plate.

Outdoor Unit Model	Panel Plate
CPR18CD(O)	X330
CPH18CD(O)	X430
CPH24CD(O)	D30
CPR24CD(O)	X430
CPR30CD(O)	D30
CPH30CD(O)	D30
CPR36CD(O)	D30
CPH36CD(O)	E30
CPH48CD(O)	E30
CPR48CD(O)	E30
CPR60CD(O)	E30
CPH60CD(O)	E30

Panel Plate X230 (Rounded grille 1)

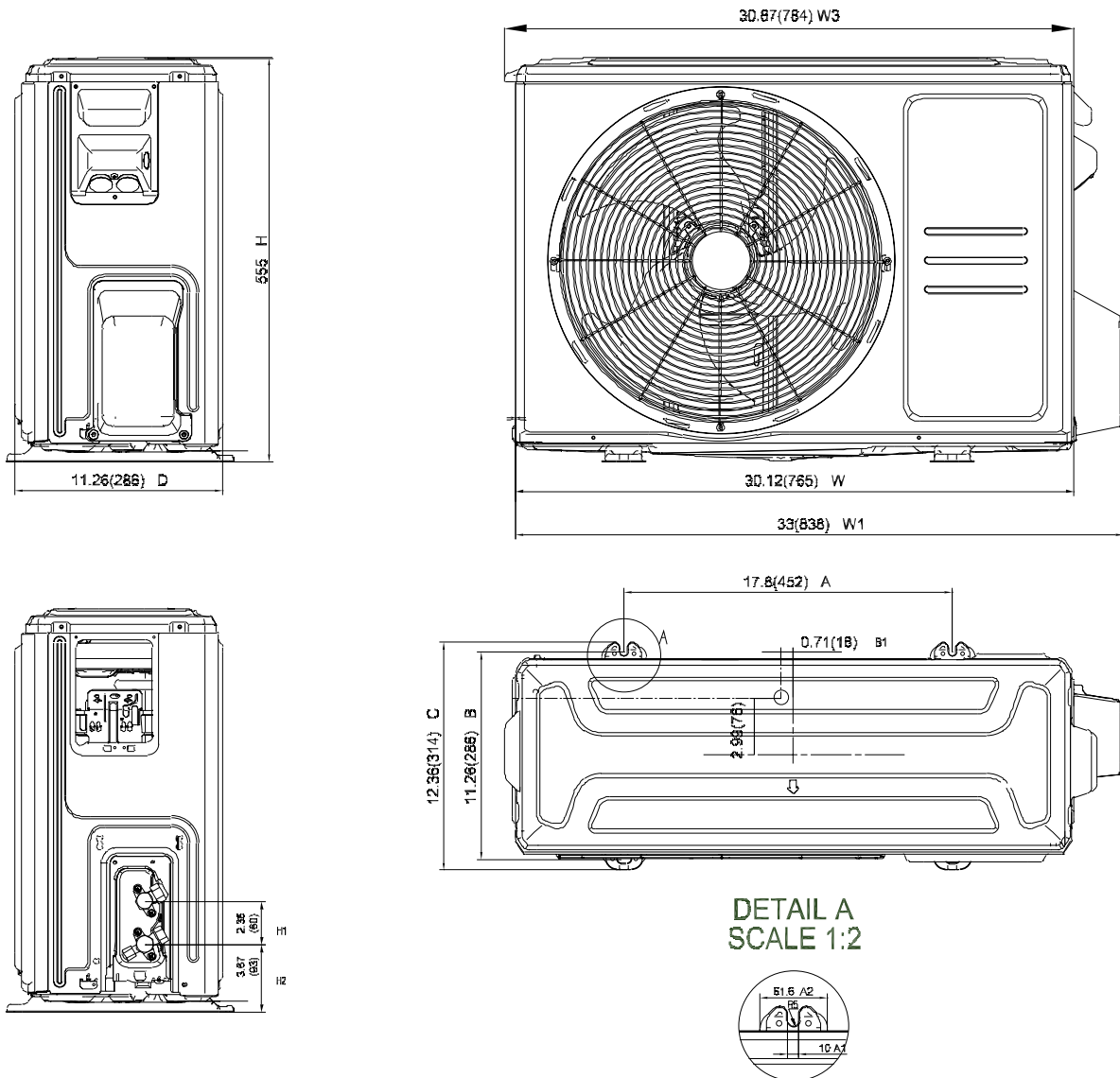

Panel Plate X230 (Rounded grille 2)

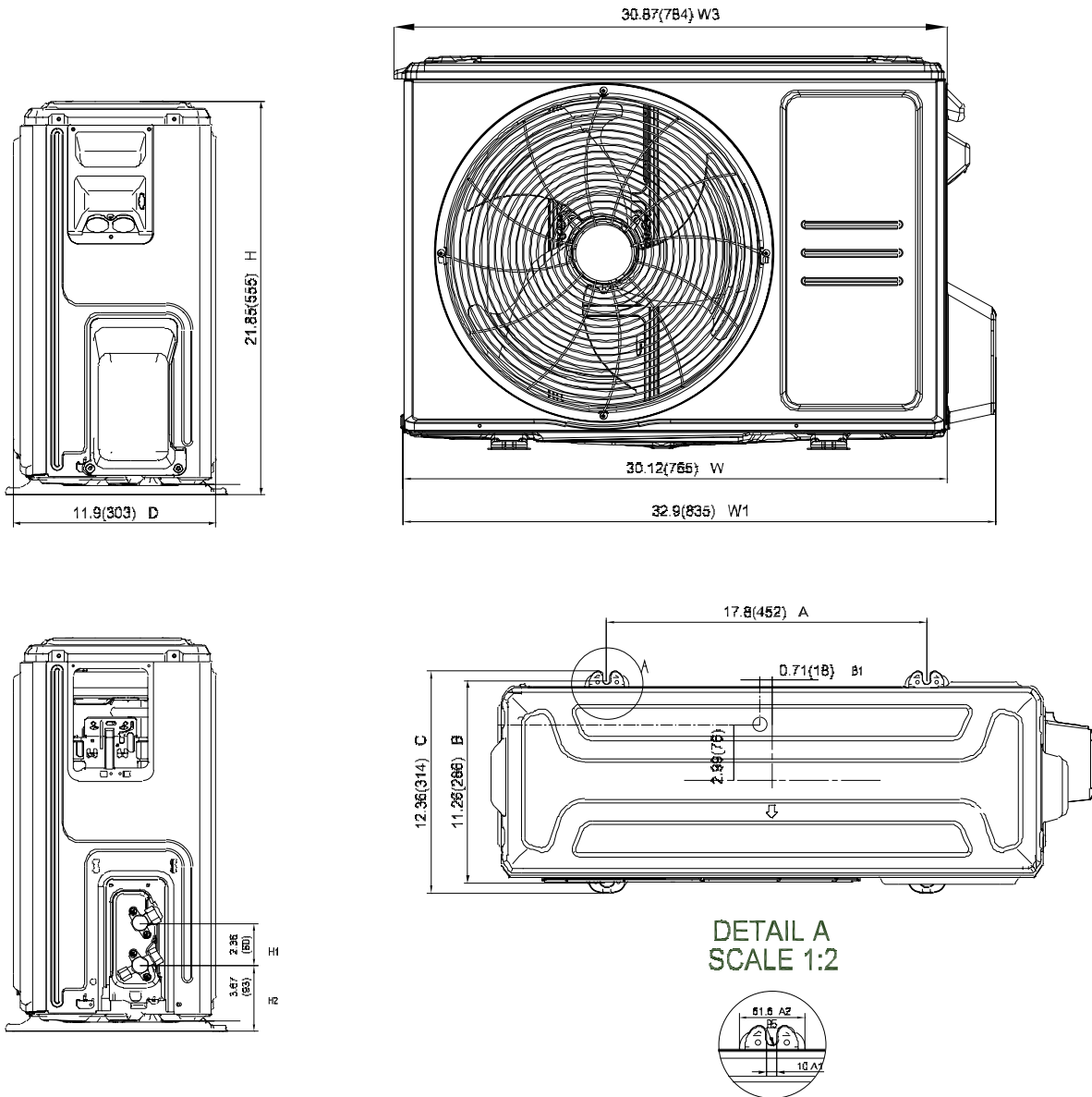

Panel Plate X230(Square grille)

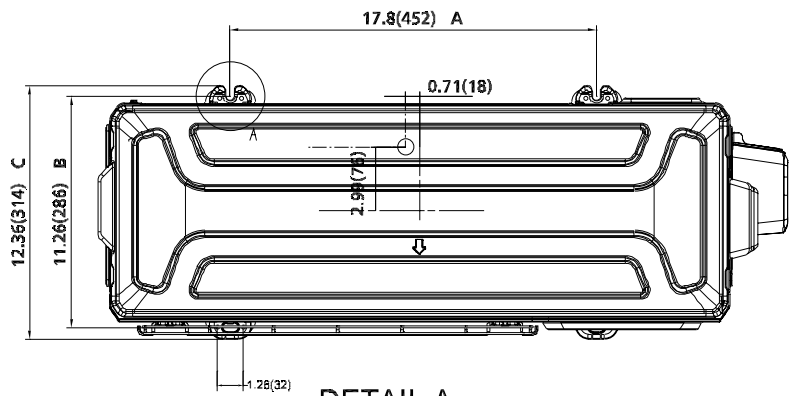
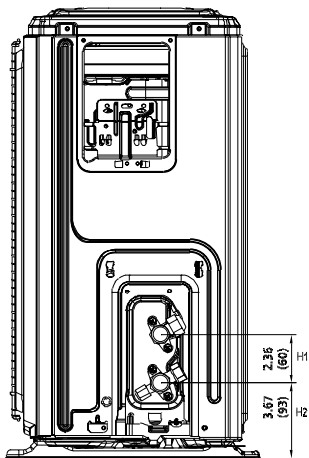
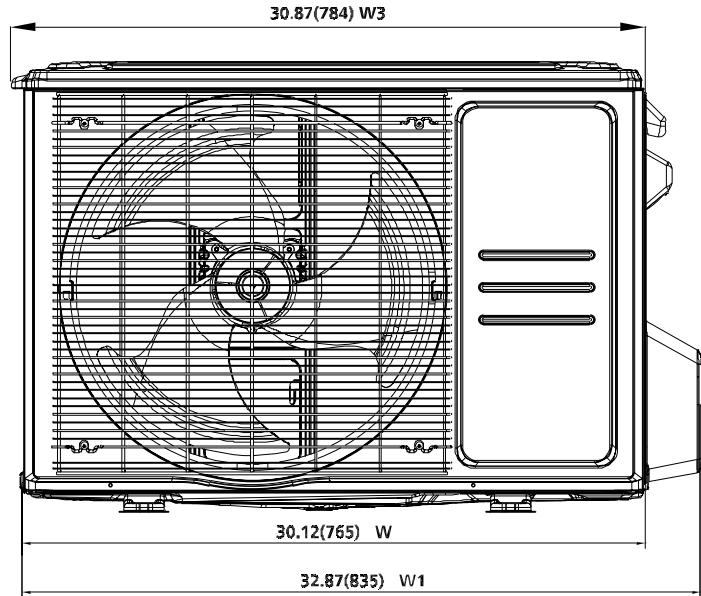
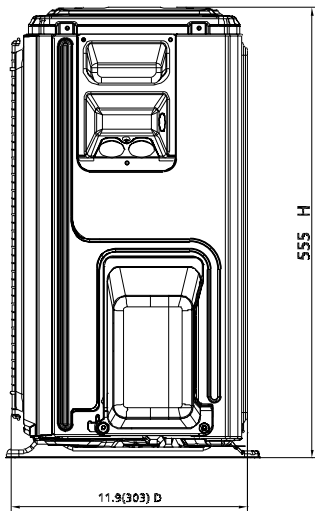

DETAIL A
SCALE 1:2

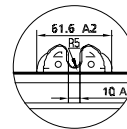

Panel Plate X330(Rounded grille 1)

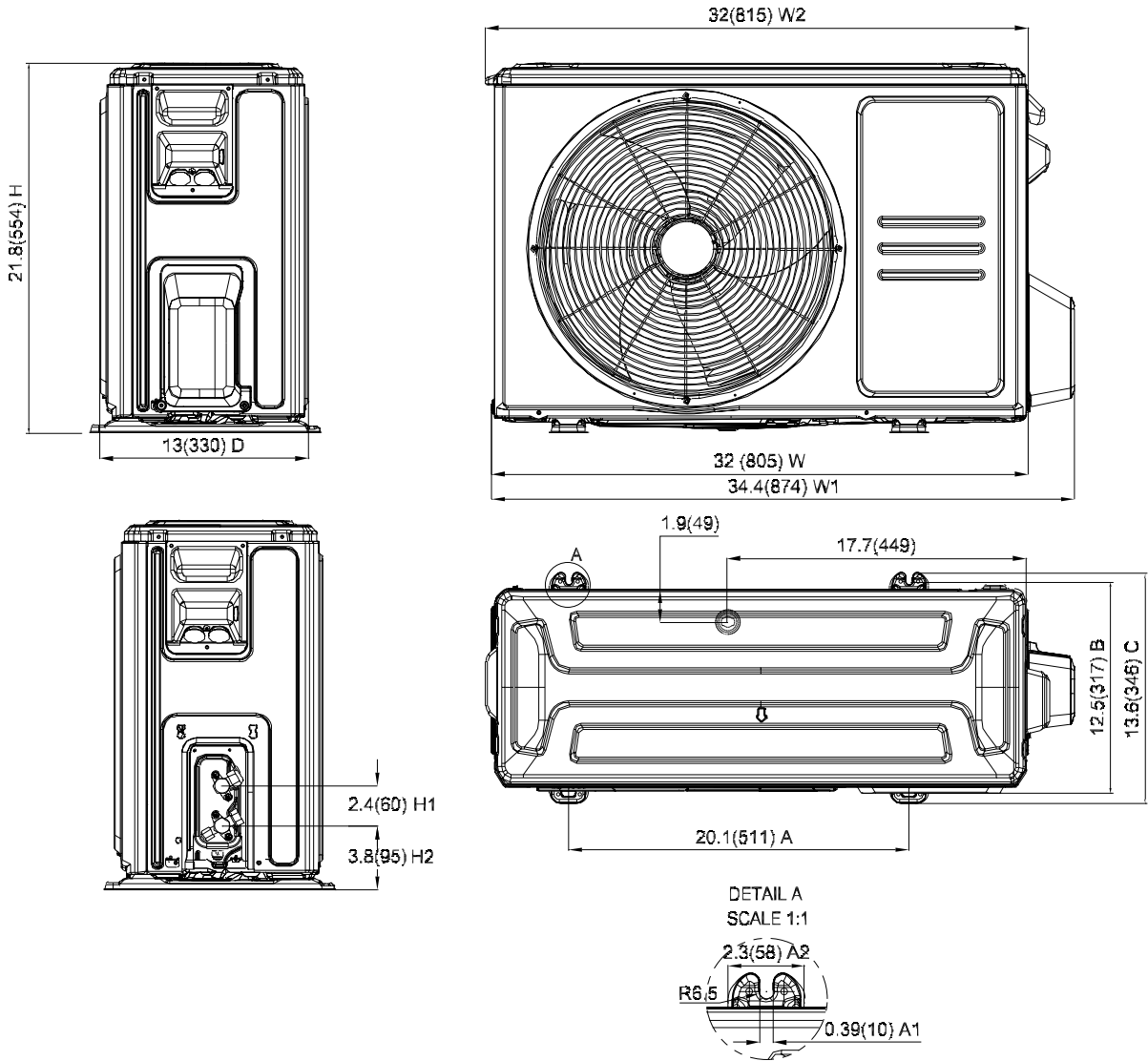

Panel Plate X330(Rounded grille 2)

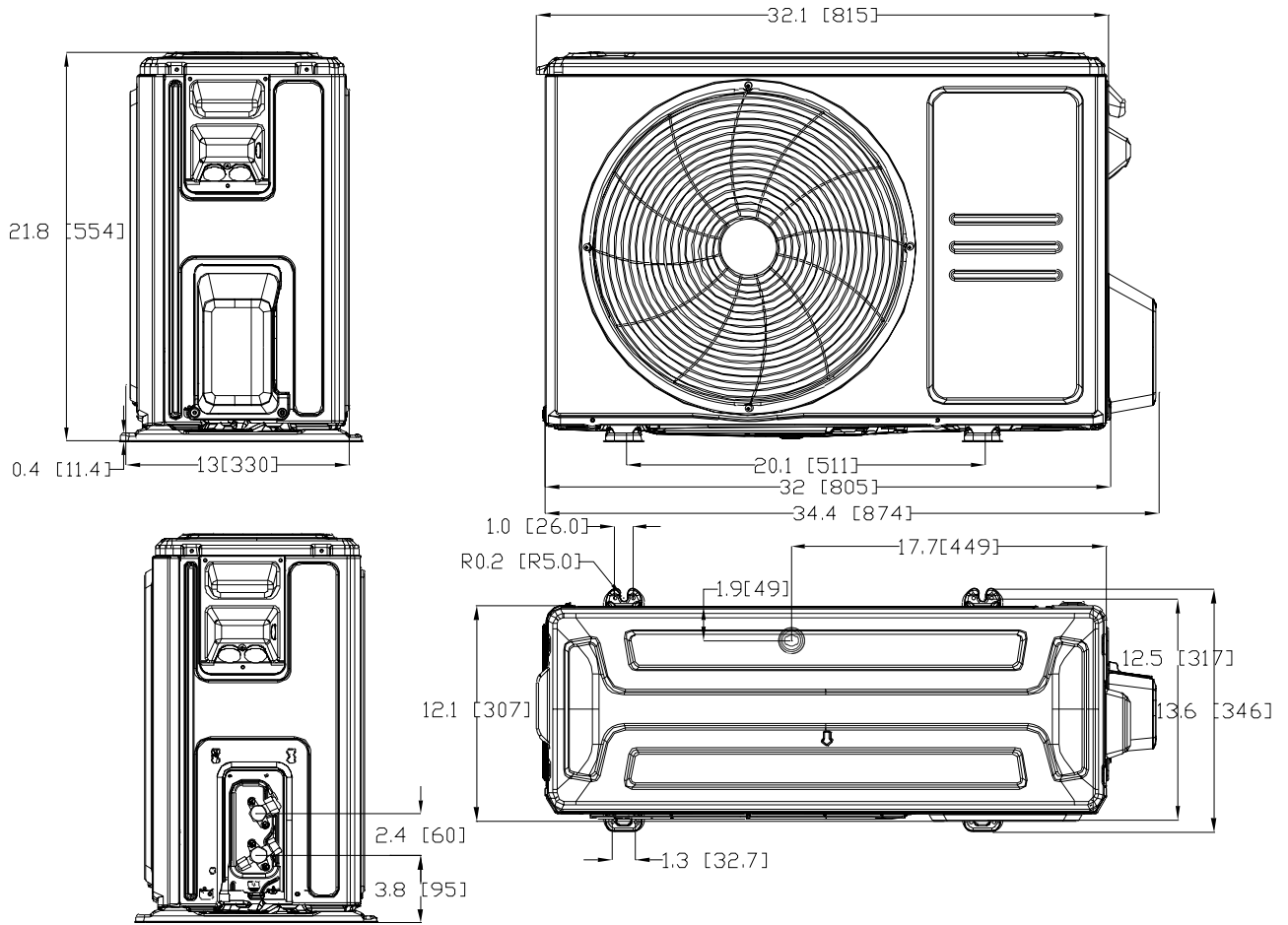

Panel Plate X330(Square grille)

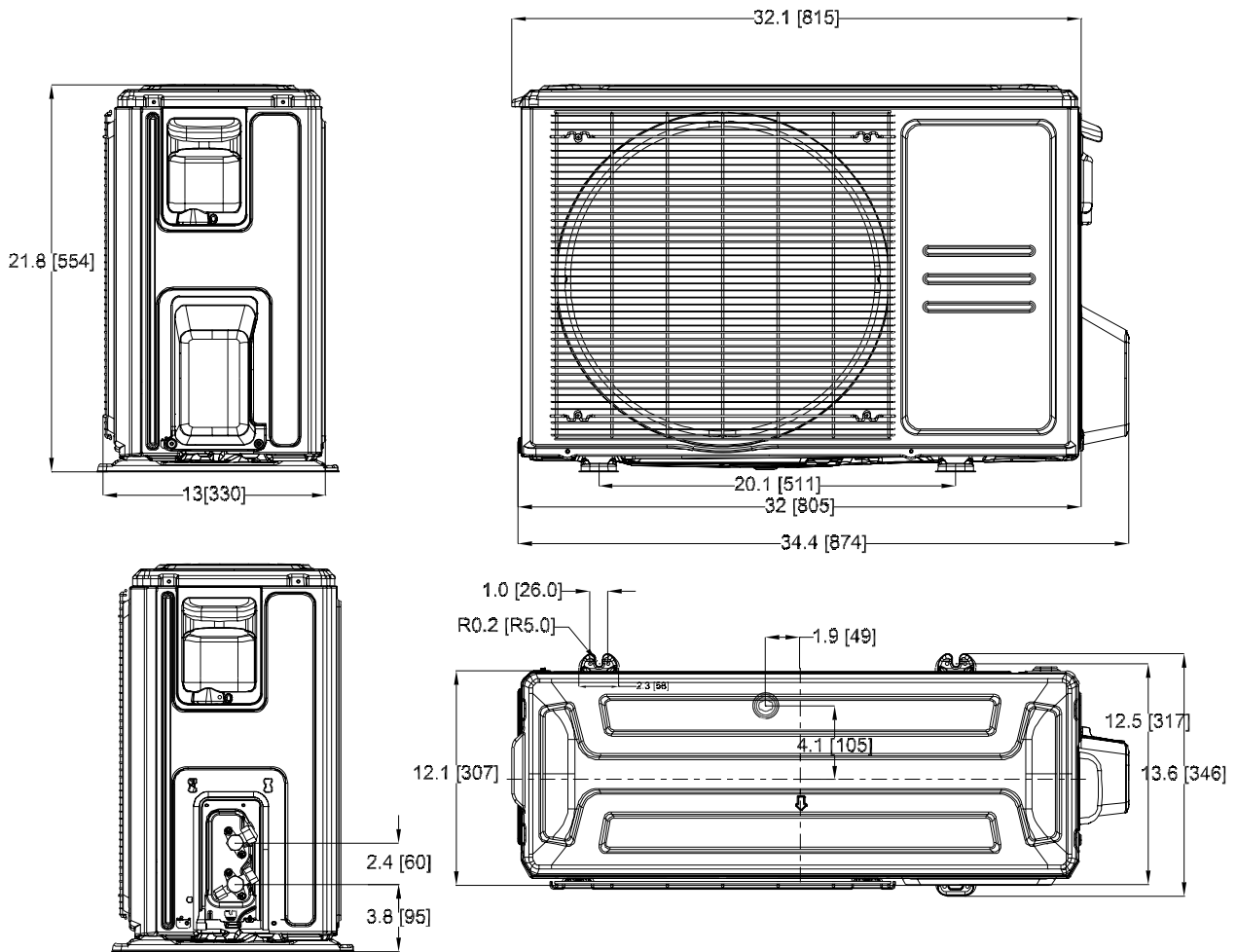

Panel Plate X430(Rounded grille 1)

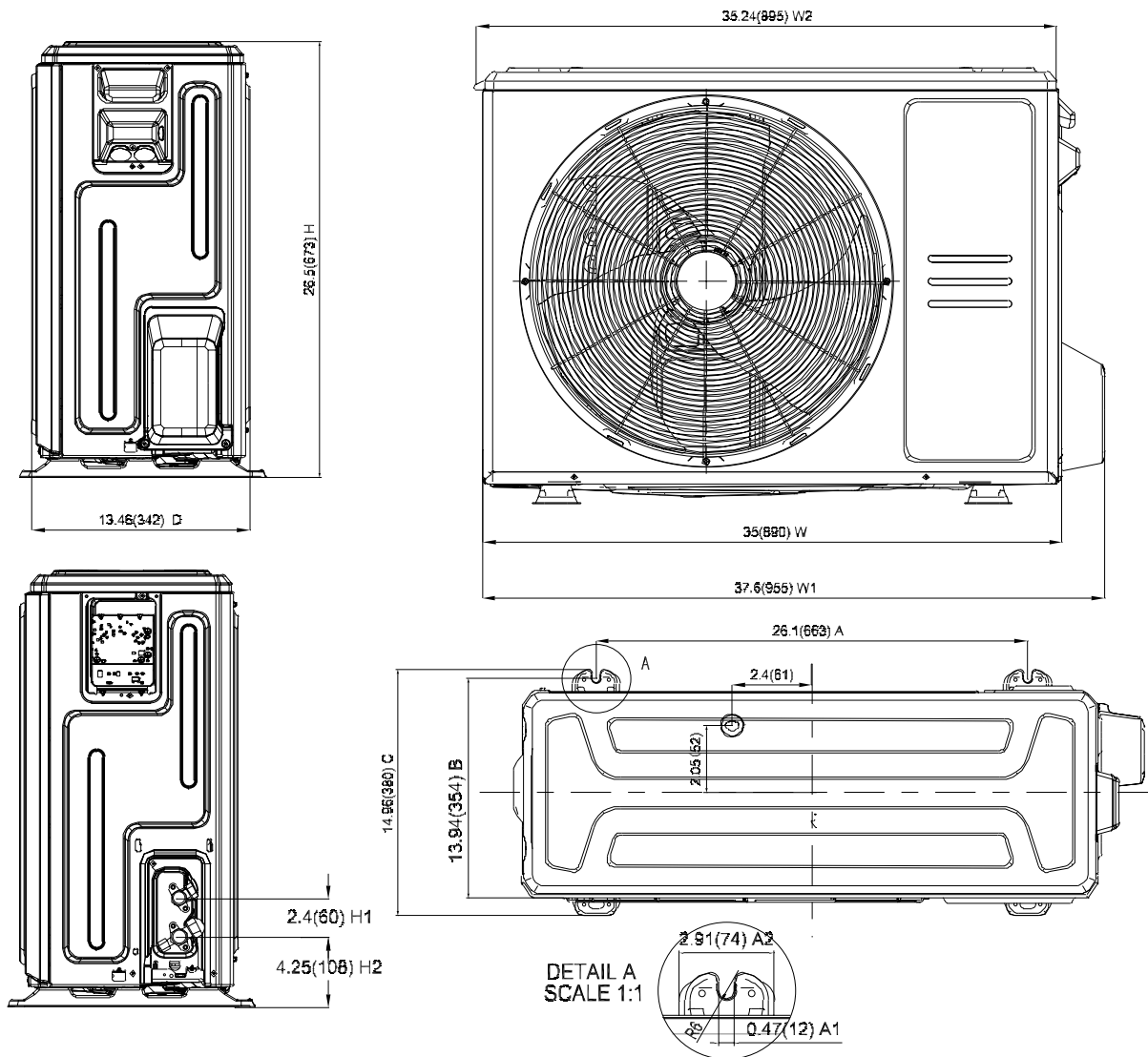

Panel Plate X430(Rounded grille 2)

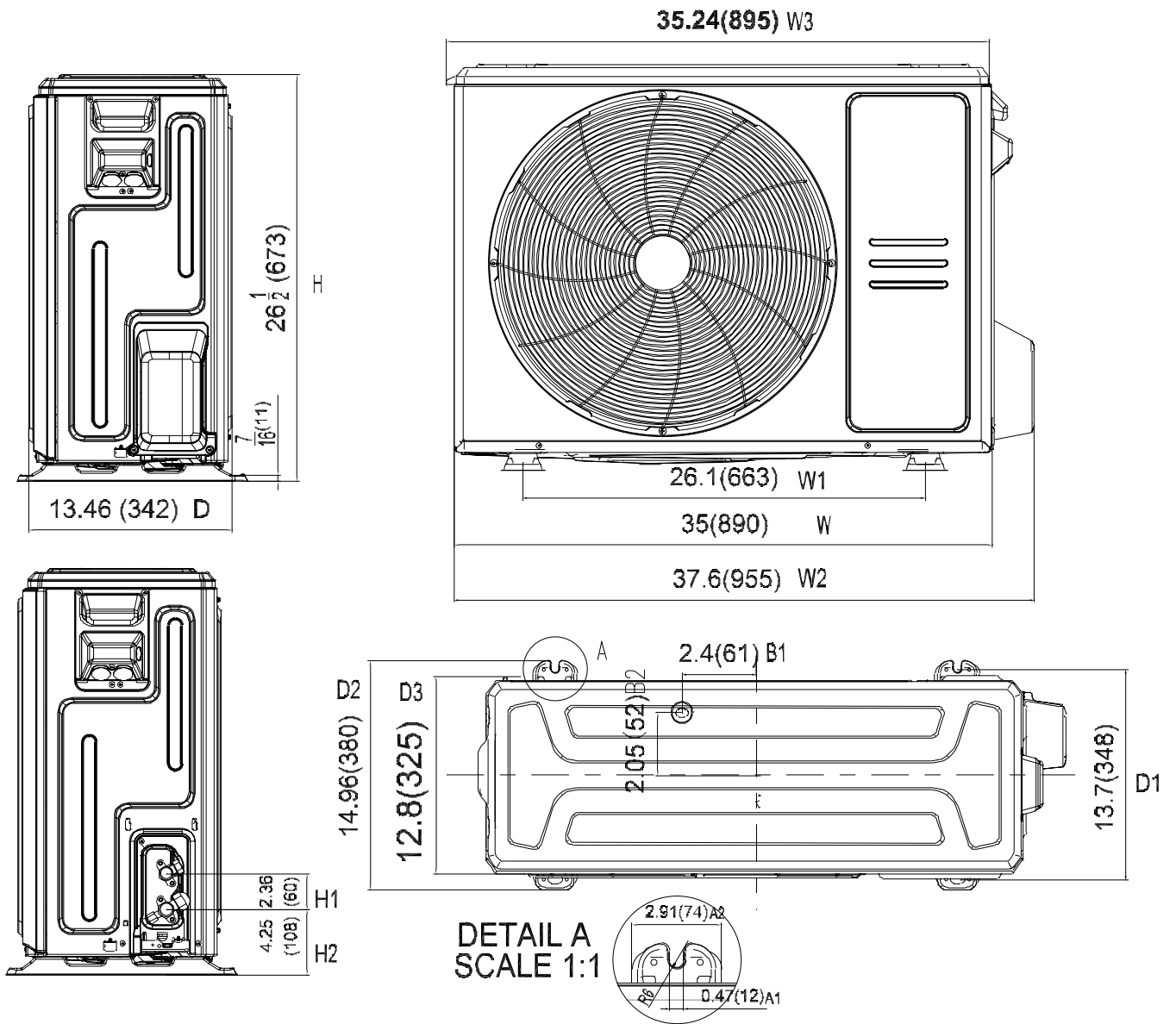

Panel Plate X430(Square grille)

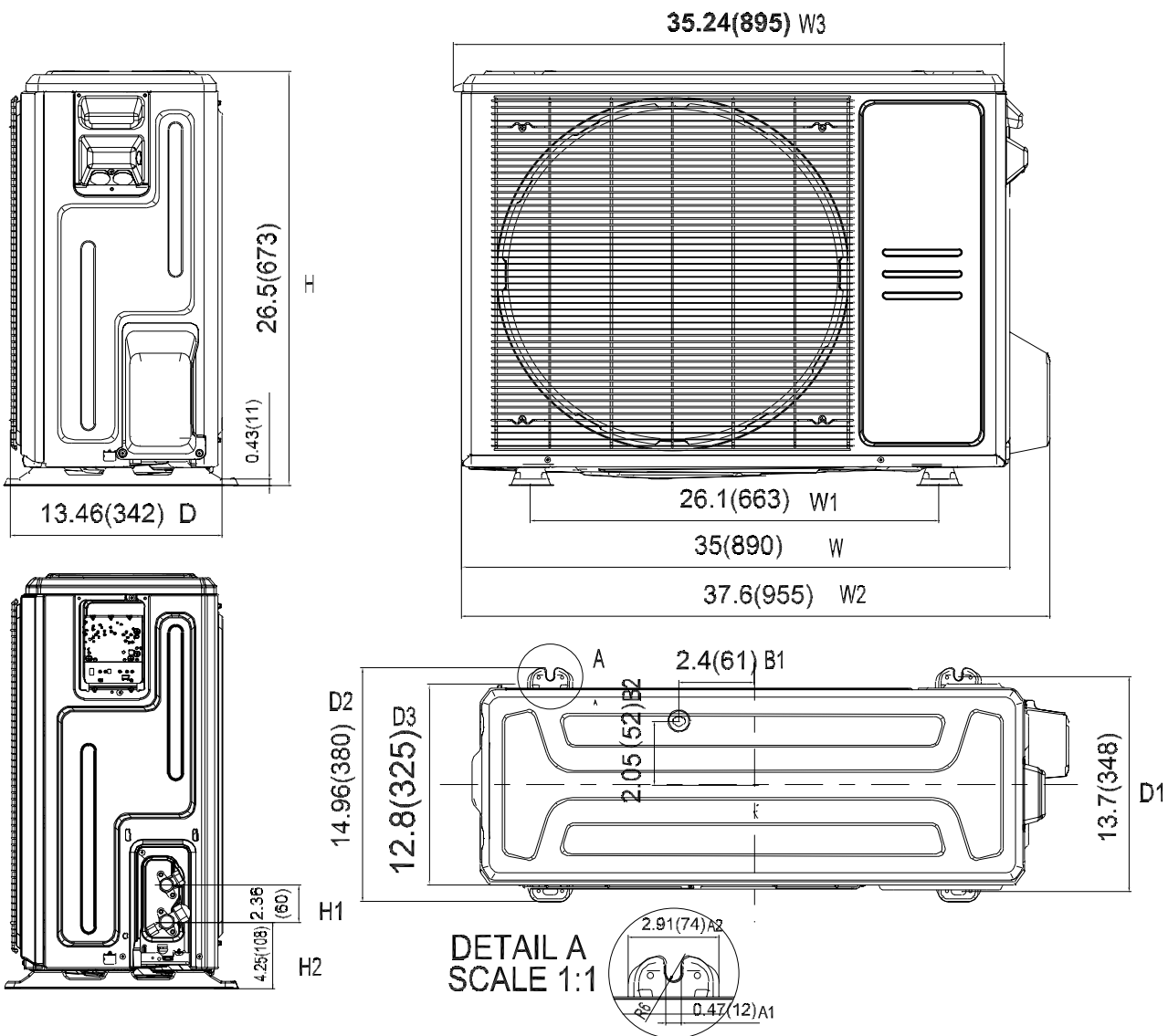

Panel Plate D30(Rounded grille 1)

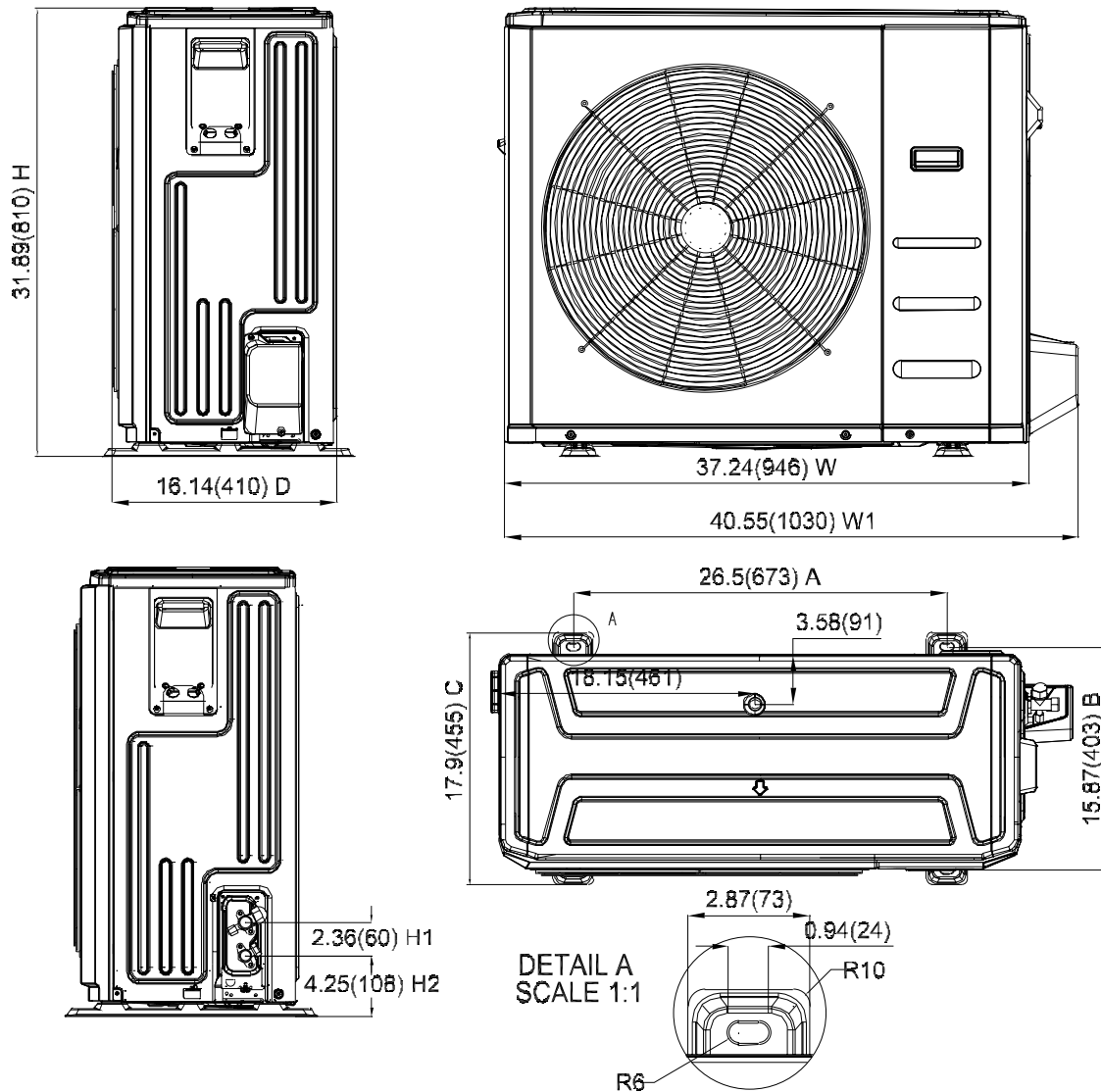

Panel Plate D30(Rounded grille 2)

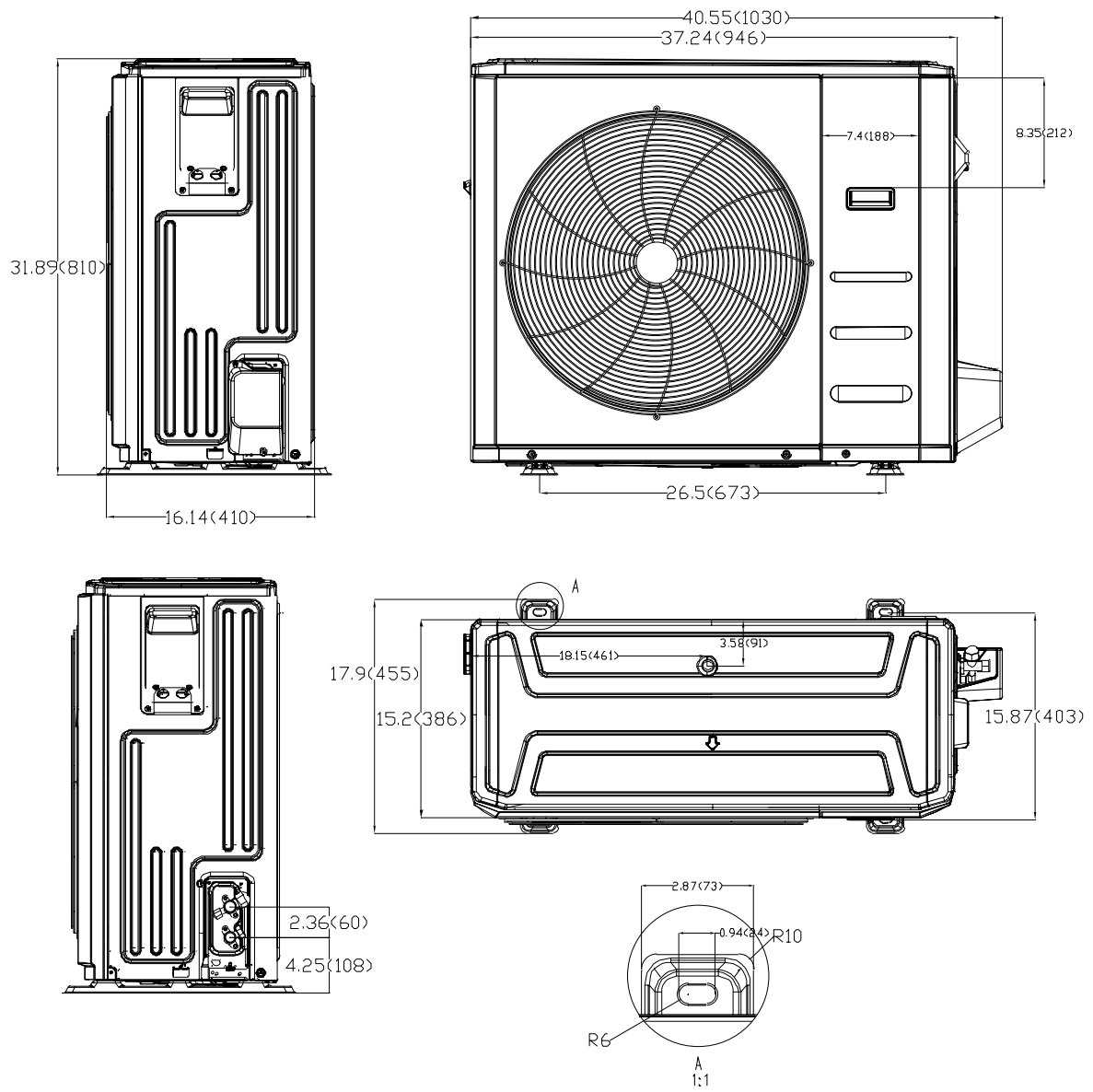

Panel Plate D30(Square grille)

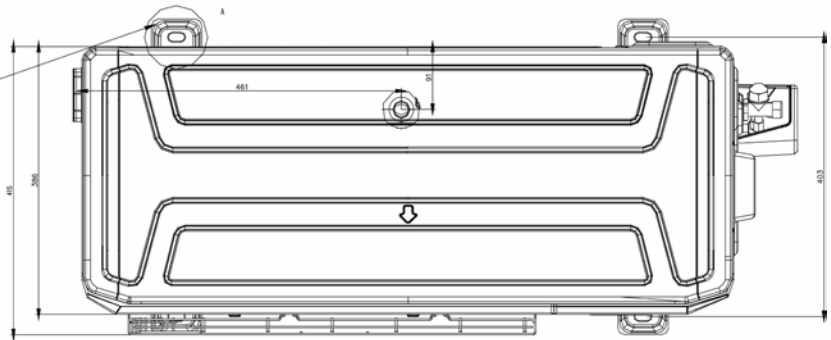
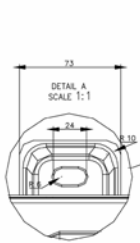
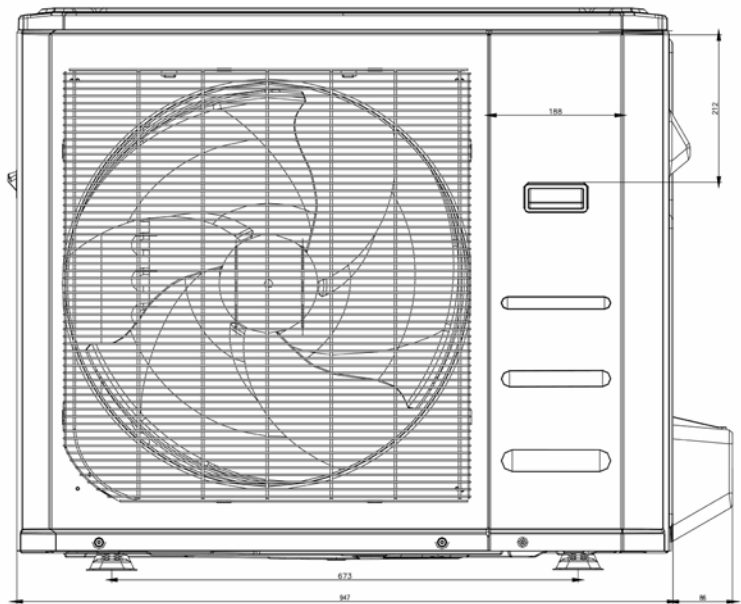
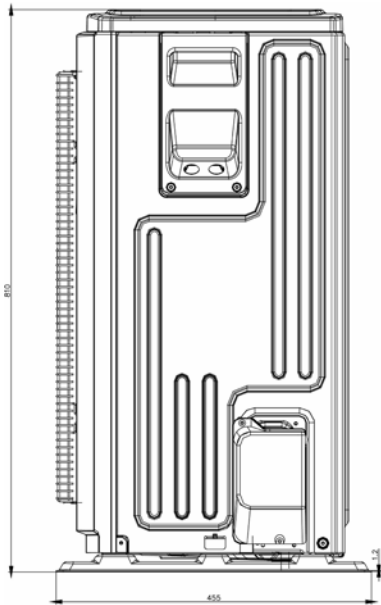

Panel Plate X630(Square grille)

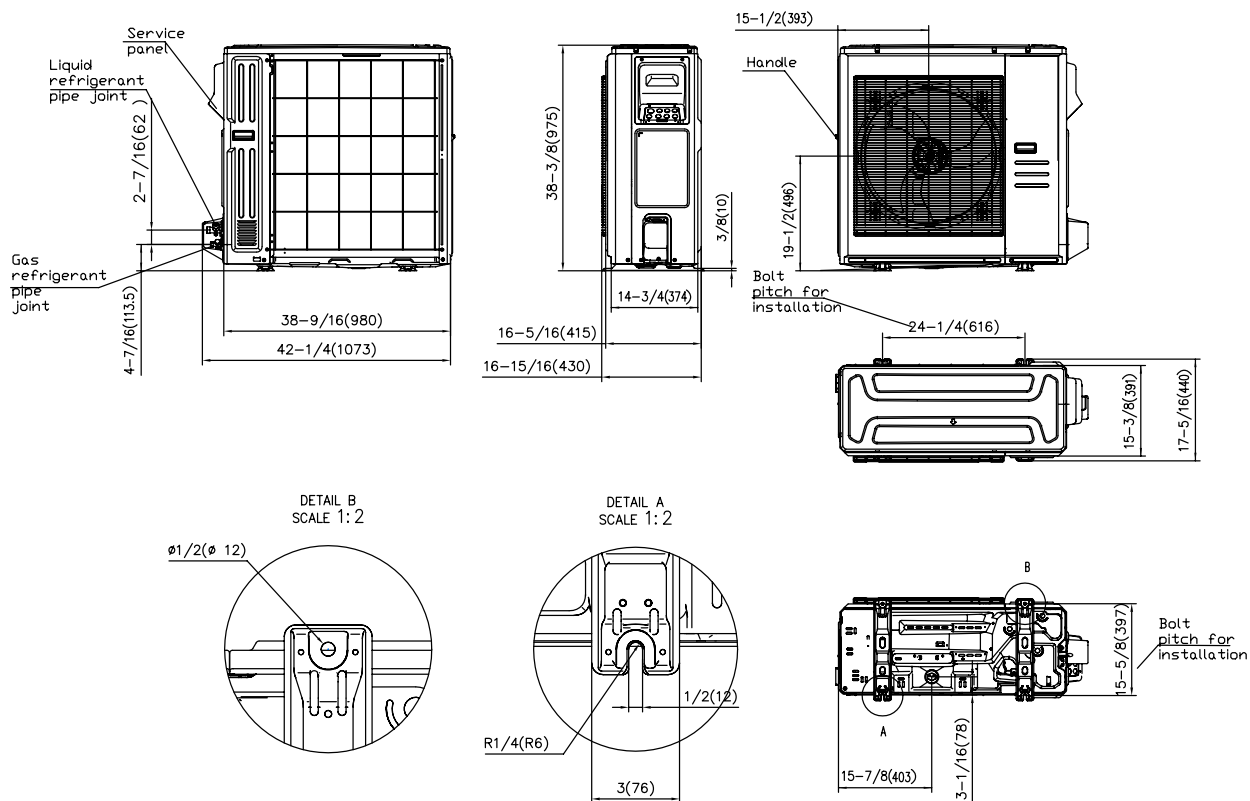

Panel Plate E30(Square grille)

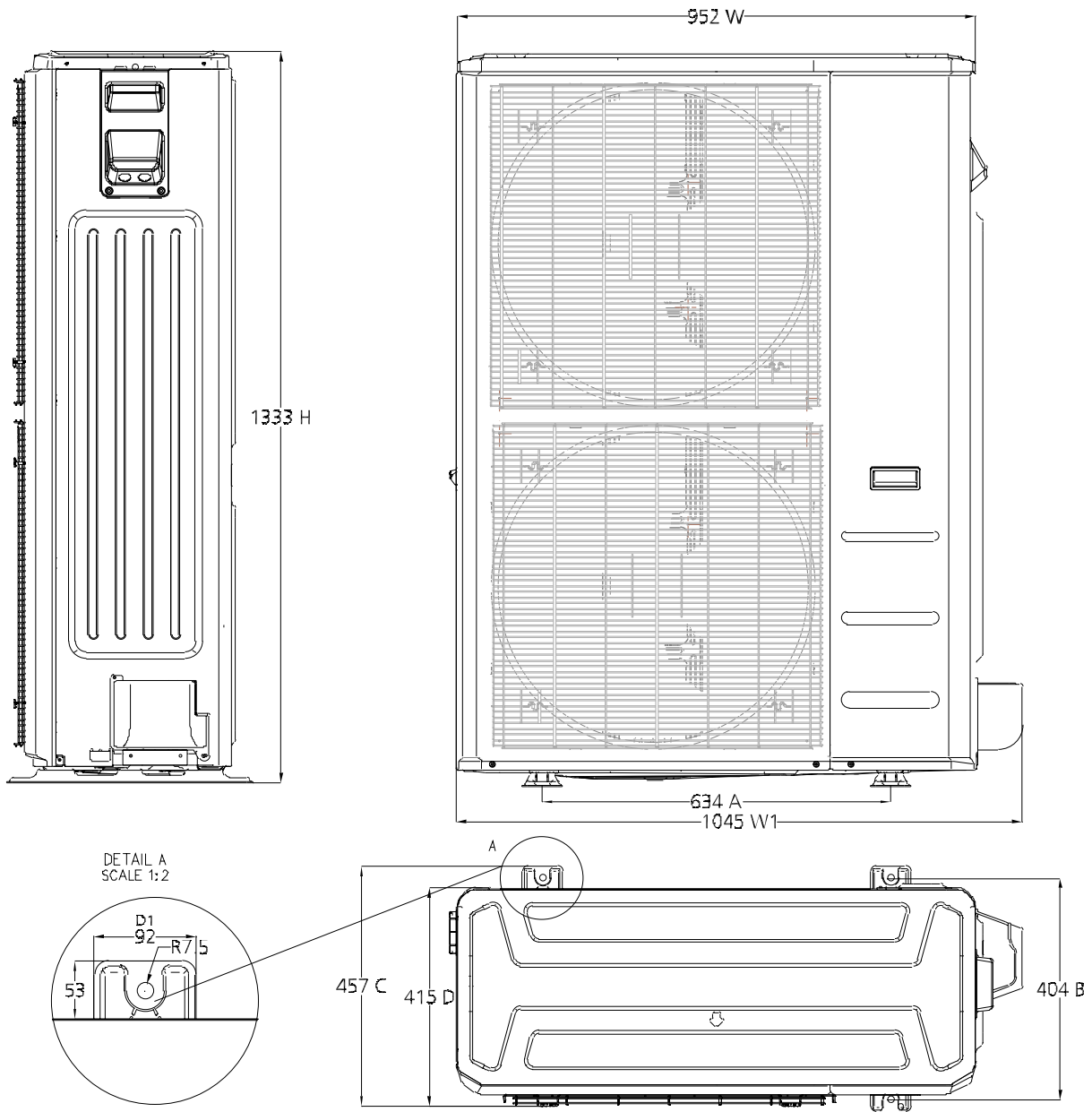

Panel Plate E30(Rounded grille 1)

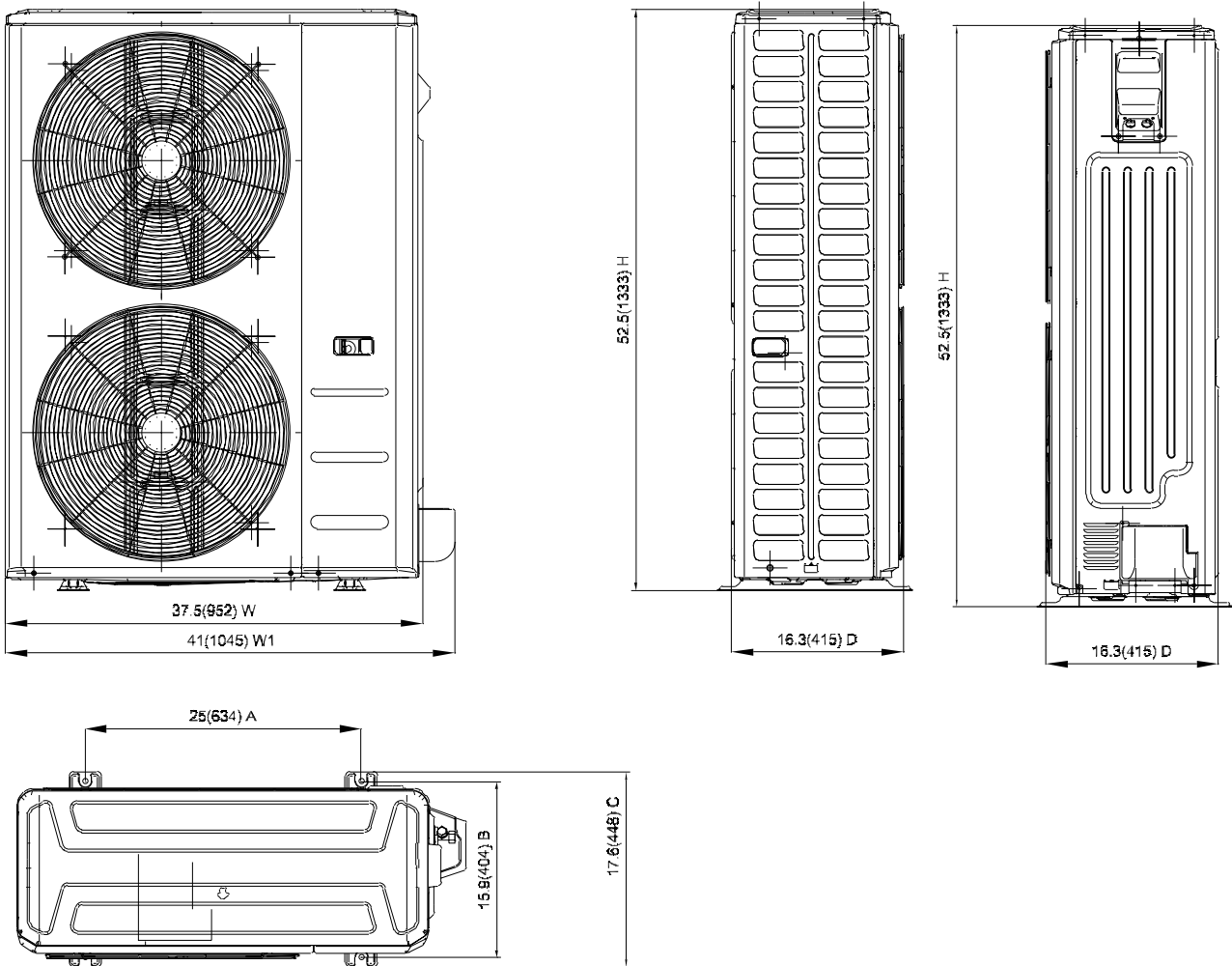

Panel Plate E30(Rounded grille 2)

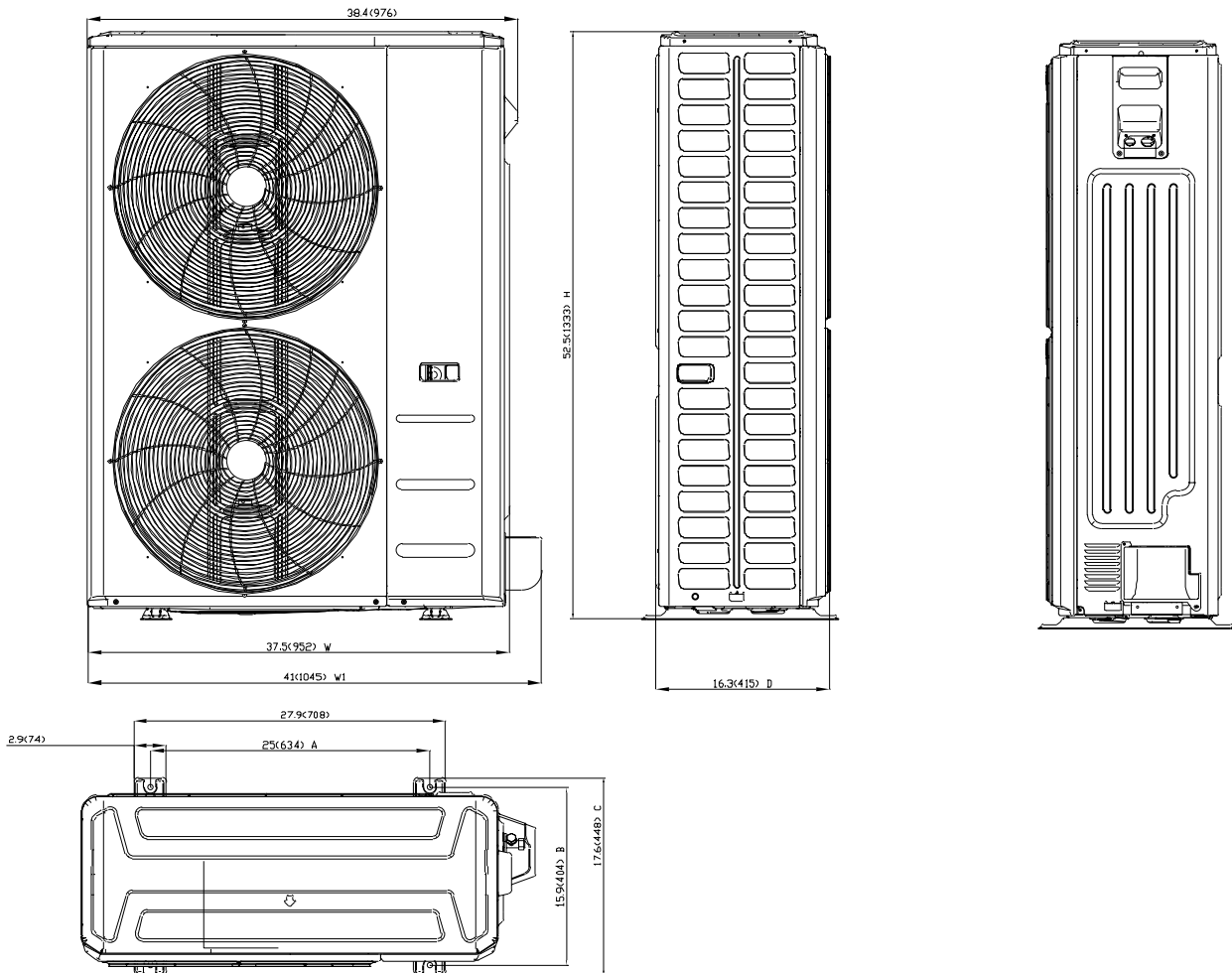

2. Service Place

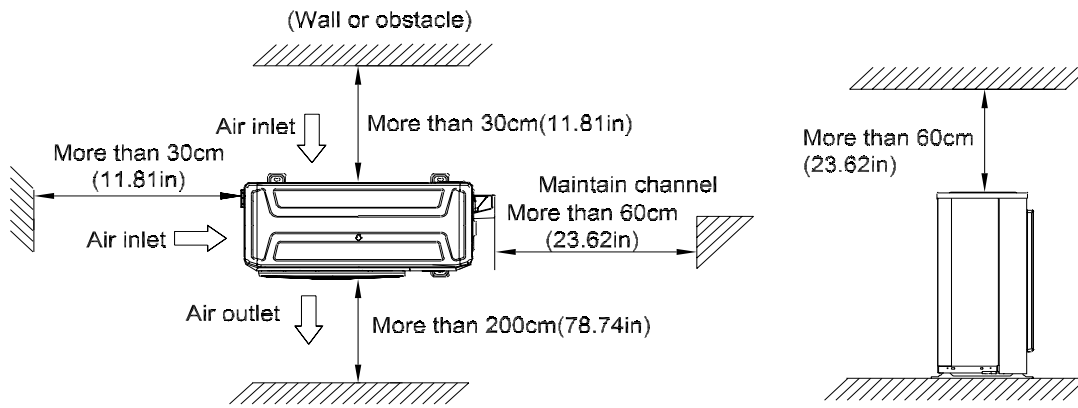

3. Capacity Correction Factor for Height Difference

Capacity(Btu/h)		6k~9k		Pipe Length (m/ft)			
		Cooling		7.5/24.6	10/32.8	20/65.6	25/82
Height difference H (m)	Indoor Upper than Outdoor	10/32.8		0.969	0.936	0.920	
		5/16.4	0.995	0.979	0.946	0.929	
		0	1.000	0.984	0.951	0.934	
	Outdoor Upper than Indoor	-5/-16.4	1.000	0.984	0.951	0.934	
		-10/-32.8		0.984	0.951	0.934	
		Heating		7.5/24.6	10/32.8	20/65.6	25/82
Height difference H (m)	Indoor Upper than Outdoor	10/32.8		0.989	0.967	0.956	
		5/16.4	1.000	0.989	0.967	0.956	
		0	1.000	0.989	0.967	0.956	
	Outdoor Upper than Indoor	-5/-16.4	0.992	0.981	0.959	0.948	
		-10/-32.8		0.973	0.952	0.941	

Capacity(Btu/h)		12k		Pipe Length (m/ft)			
		Cooling		7.5/24.6	10/32.8	20/65.6	25/82
Height difference H (m)	Indoor Upper than Outdoor	10/32.8		0.974	0.953	0.942	
		5/16.4	0.995	0.984	0.962	0.951	
		0	1.000	0.989	0.967	0.956	
	Outdoor Upper than Indoor	-5/-16.4	1.000	0.989	0.967	0.956	
		-10/-32.8		0.989	0.967	0.956	
		Heating		7.5/24.6	10/32.8	20/65.6	25/82
Height difference H (m)	Indoor Upper than Outdoor	10/32.8		0.994	0.981	0.974	
		5/16.4	1.000	0.994	0.981	0.974	
		0	1.000	0.994	0.981	0.974	
	Outdoor Upper than Indoor	-5/-16.4	0.992	0.986	0.973	0.966	
		-10/-32.8		0.978	0.965	0.958	

Capacity(Btu/h)		18k		Pipe Length (m/ft)			
		Cooling		7.5/24.6	10/32.8	20/65.6	30/98.4
Height difference H (m)	Indoor Upper than Outdoor	20/65.6				0.941	0.919
		10/32.8		0.974	0.951	0.928	
		5/16.4	0.995	0.983	0.960	0.937	
		0	1.000	0.988	0.965	0.942	
	Outdoor Upper than Indoor	-5/-16.4	1.000	0.988	0.965	0.942	
		-10/-32.8		0.988	0.965	0.942	
		-20/-65.6			0.965	0.942	

Capacity(Btu/h)	18k		Pipe Length (m/ft)			
Heating			7.5/24.6	10/32.8	20/65.6	30/98.4
Height difference H (m)	Indoor Upper than Outdoor	20/65.6			0.987	0.978
		10/32.8		0.996	0.987	0.978
		5/16.4	1.000	0.996	0.987	0.978
	0		1.000	0.996	0.987	0.978
	Outdoor Upper than Indoor	-5/-16.4	0.992	0.988	0.979	0.970
		-10/-32.8		0.980	0.971	0.962
		-20/-65.6			0.963	0.955

Capacity (Btu/h)	24k		Pipe Length (m/ft)					
Cooling			7.5/24.6	10/32.8	20/65.6	30/98.4	40/131.2	50/164
Height difference H (m)	Indoor Upper than Outdoor	25/82				0.917	0.898	0.879
		20/65.6			0.946	0.926	0.907	0.887
		10/32.8		0.975	0.955	0.936	0.916	0.896
		5/16.4	0.995	0.985	0.965	0.945	0.925	0.905
	0		1.000	0.990	0.970	0.950	0.930	0.910
	Outdoor Upper than Indoor	-5/-16.4	1.000	0.990	0.970	0.950	0.930	0.910
		-10/-32.8		0.990	0.970	0.950	0.930	0.910
		-20/-65.6			0.970	0.950	0.930	0.910
		-25/-82				0.950	0.930	0.910

Heating			7.5/24.6	10/32.8	20/65.6	30/98.4	40/131.2	50/164
Height difference H (m)	Indoor Upper than Outdoor	25/82				0.984	0.978	0.972
		20/65.6			0.991	0.984	0.978	0.972
		10/32.8		0.997	0.991	0.984	0.978	0.972
		5/16.4	1.000	0.997	0.991	0.984	0.978	0.972
	0		1.000	0.997	0.991	0.984	0.978	0.972
	Outdoor Upper than Indoor	-5/-16.4	0.992	0.989	0.983	0.977	0.970	0.964
		-10/-32.8		0.981	0.975	0.969	0.963	0.957
		-20/-65.6			0.967	0.961	0.955	0.949
		-25/-82				0.953	0.947	0.941

Capacity (Btu/h)	30k		Pipe Length (m/ft)					
Cooling			7.5/24.6	10/32.8	20/65.6	30/98.4	40/131.2	50/164
Height difference H (m)	Indoor Upper than Outdoor	25/82				0.891	0.862	0.832
		20/65.6			0.930	0.900	0.871	0.841
		10/32.8		0.970	0.940	0.910	0.879	0.849
		5/16.4	0.995	0.980	0.949	0.919	0.888	0.858
		0	1.000	0.985	0.954	0.923	0.893	0.862
	Outdoor Upper than Indoor	-5/-16.4	1.000	0.985	0.954	0.923	0.893	0.862
		-10/-32.8		0.985	0.954	0.923	0.893	0.862
		-20/-65.6			0.954	0.923	0.893	0.862
-25/-82					0.923	0.893	0.862	
Heating			7.5/24.6	10/32.8	20/65.6	30/98.4	40/131.2	50/164
Height difference H (m)	Indoor Upper than Outdoor	25/82				0.961	0.945	0.929
		20/65.6			0.976	0.961	0.945	0.929
		10/32.8		0.992	0.976	0.961	0.945	0.929
		5/16.4	1.000	0.992	0.976	0.961	0.945	0.929
		0	1.000	0.992	0.976	0.961	0.945	0.929
	Outdoor Upper than Indoor	-5/-16.4	0.992	0.984	0.969	0.953	0.937	0.922
		-10/-32.8		0.976	0.961	0.945	0.930	0.914
		-20/-65.6			0.953	0.938	0.922	0.907
-25/-82					0.930	0.915	0.900	

Capacity (Btu/h)	36k		Pipe Length (m/ft)					
Cooling			7.5/24.6	15/49.2	25/82	35/114.8	50/164	65/213.3
Height difference H (m)	Indoor Upper than Outdoor	30/98.4				0.889	0.850	0.812
		20/65.6			0.924	0.898	0.859	0.820
		10/32.8		0.959	0.933	0.907	0.868	0.828
		5/16.4	0.995	0.969	0.942	0.916	0.876	0.837
		0	1.000	0.974	0.947	0.921	0.881	0.841
	Outdoor Upper than Indoor	-5/-16.4	1.000	0.974	0.947	0.921	0.881	0.841
		-10/-32.8		0.974	0.947	0.921	0.881	0.841
		-20/-65.6			0.947	0.921	0.881	0.841
-30/-98.4					0.921	0.881	0.841	
Heating			7.5/24.6	15/49.2	25/82	35/114.8	50/164	65/213.3
Height difference H (m)	Indoor Upper than Outdoor	30/98.4				0.964	0.945	0.927
		20/65.6			0.976	0.964	0.945	0.927
		10/32.8		0.988	0.976	0.964	0.945	0.927
		5/16.4	1.000	0.988	0.976	0.964	0.945	0.927
		0	1.000	0.988	0.976	0.964	0.945	0.927
	Outdoor Upper than Indoor	-5/-16.4	0.992	0.980	0.968	0.956	0.938	0.920
		-10/-32.8		0.972	0.960	0.948	0.930	0.912
		-20/-65.6			0.952	0.941	0.923	0.905
-30/-98.4					0.933	0.915	0.898	

Capacity (Btu/h)	48k		Pipe Length (m/ft)					
Cooling			7.5/24.6	15/49.2	25/82	35/114.8	50/164	65/213.3
Height difference H (m)	Indoor Upper than Outdoor	30/98.4				0.884	0.843	0.802
		20/65.6			0.920	0.893	0.852	0.810
		10/32.8		0.957	0.930	0.902	0.860	0.819
		5/16.4	0.995	0.967	0.939	0.911	0.869	0.827
		0	1.000	0.972	0.944	0.916	0.873	0.831
	Outdoor Upper than Indoor	-5/-16.4	1.000	0.972	0.944	0.916	0.873	0.831
		-10/-32.8		0.972	0.944	0.916	0.873	0.831
		-20/-65.6			0.944	0.916	0.873	0.831
		-30/-98.4				0.916	0.873	0.831
	Heating			7.5/24.6	15/49.2	25/82	35/114.8	50/164
Height difference H (m)	Indoor Upper than Outdoor	30/98.4				0.958	0.936	0.915
		20/65.6			0.972	0.958	0.936	0.915
		10/32.8		0.986	0.972	0.958	0.936	0.915
		5/16.4	1.000	0.986	0.972	0.958	0.936	0.915
		0	1.000	0.986	0.972	0.958	0.936	0.915
	Outdoor Upper than Indoor	-5/-16.4	0.992	0.978	0.964	0.950	0.929	0.908
		-10/-32.8		0.970	0.956	0.942	0.921	0.900
		-20/-65.6			0.949	0.935	0.914	0.893
-30/-98.4					0.927	0.907	0.886	

Capacity (Btu/h)	60k		Pipe Length (m/ft)					
Cooling			7.5/24.6	15/49.2	25/82	35/114.8	50/164	65/213.3
Height difference H (m)	Indoor Upper than Outdoor	30/98.4				0.870	0.823	0.775
		20/65.6			0.911	0.879	0.831	0.783
		10/32.8		0.953	0.920	0.888	0.840	0.791
		5/16.4	0.995	0.962	0.930	0.897	0.848	0.799
		0	1.000	0.967	0.934	0.902	0.852	0.803
	Outdoor Upper than Indoor	-5/-16.4	1.000	0.967	0.934	0.902	0.852	0.803
		-10/-32.8		0.967	0.934	0.902	0.852	0.803
		-20/-65.6			0.934	0.902	0.852	0.803
-30/-98.4					0.902	0.852	0.803	
Heating			7.5/24.6	15/49.2	25/82	35/114.8	50/164	65/213.3
Height difference H (m)	Indoor Upper than Outdoor	30/98.4				0.955	0.932	0.909
		20/65.6			0.970	0.955	0.932	0.909
		10/32.8		0.985	0.970	0.955	0.932	0.909
		5/16.4	1.000	0.985	0.970	0.955	0.932	0.909
		0	1.000	0.985	0.970	0.955	0.932	0.909
	Outdoor Upper than Indoor	-5/-16.4	0.992	0.977	0.962	0.947	0.924	0.902
		-10/-32.8		0.969	0.954	0.939	0.917	0.895
		-20/-65.6			0.947	0.932	0.910	0.887
-30/-98.4					0.924	0.902	0.880	

4. Noise Criterion Curves

Outdoor Unit

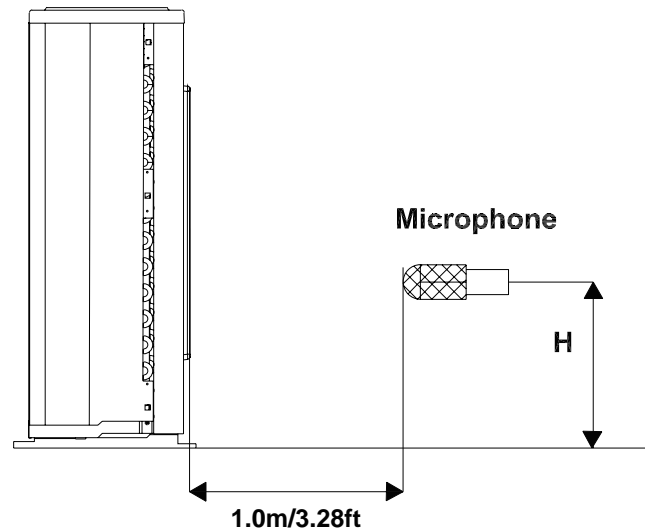

Note: $H = 0.5 \times$ height of outdoor unit

Notes:

- Sound measured at 1.0m/3.25ft away from the center of the unit.
- Data is valid at free field condition
- Data is valid at nominal operation condition
- Reference acoustic pressure $OdB=20\mu Pa$
- Sound level will vary depending on arrange off actors such as the construction (acoustic absorption coefficient) of particular room in which the equipment is installed.
- The operating conditions are assumed to be standard.

CPR18CD(O)

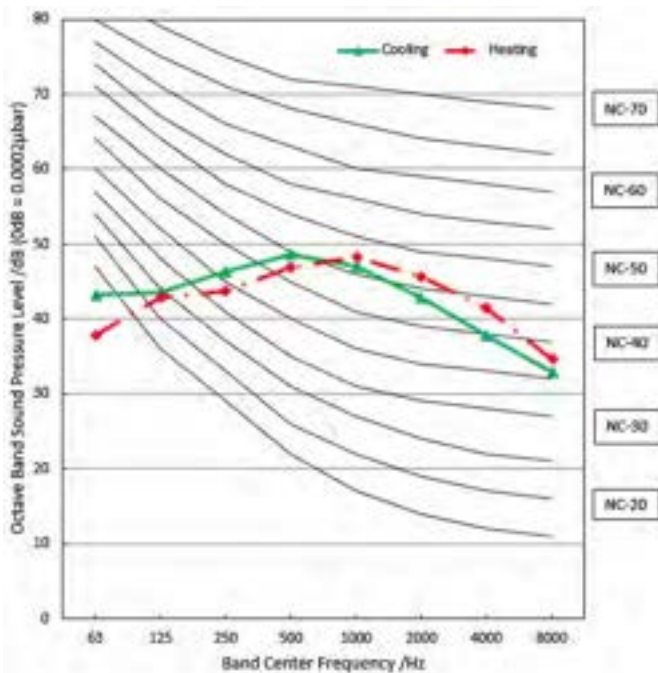

CPR24CD(O)

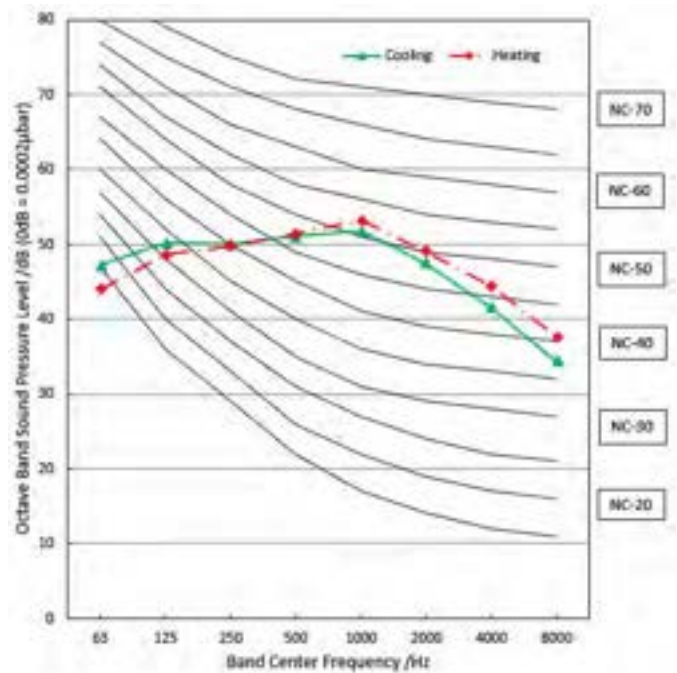

CPR30CD(O)

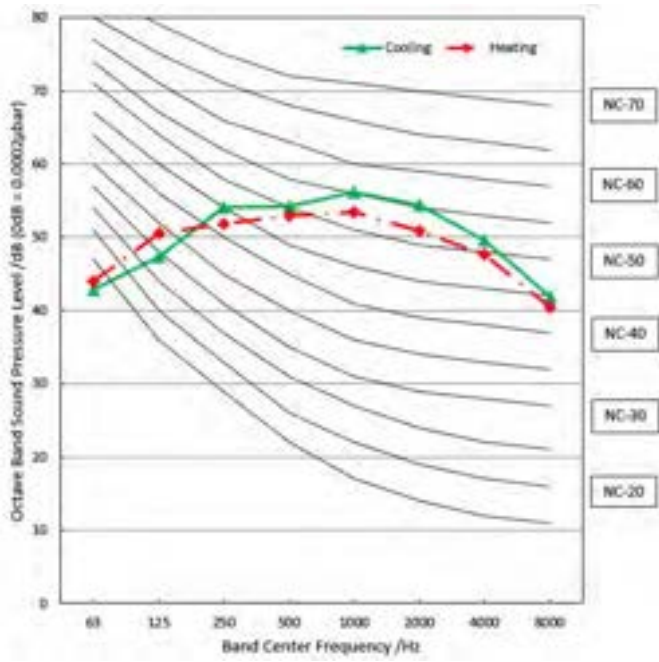

CPR36CD(O)

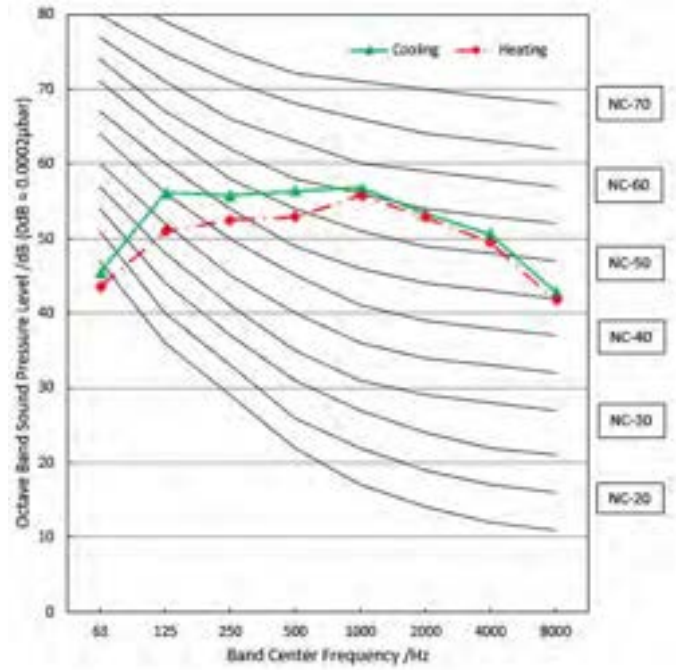

CPR48CD(O)

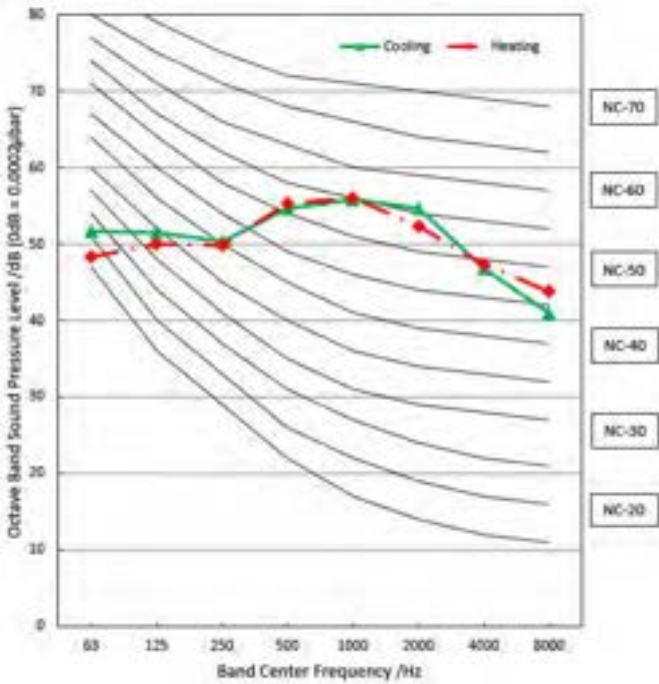

CPR60CD(O)

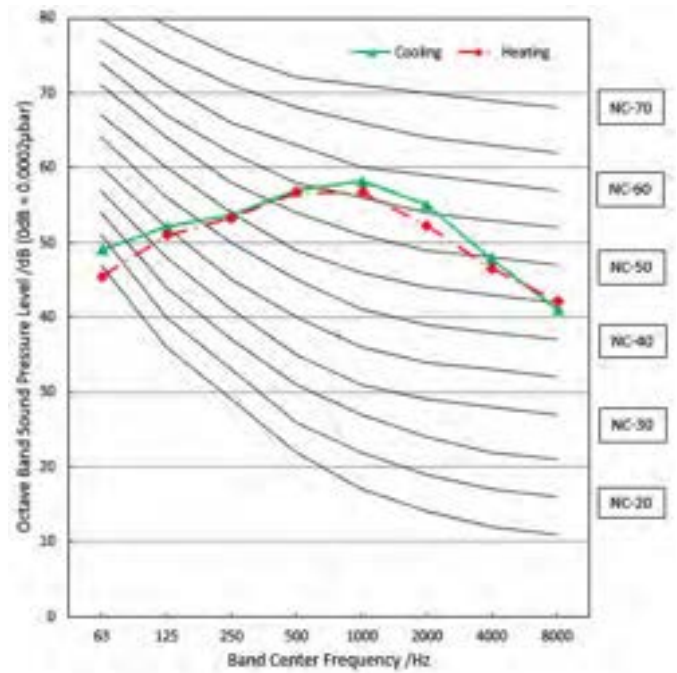

CPH18CD(O)

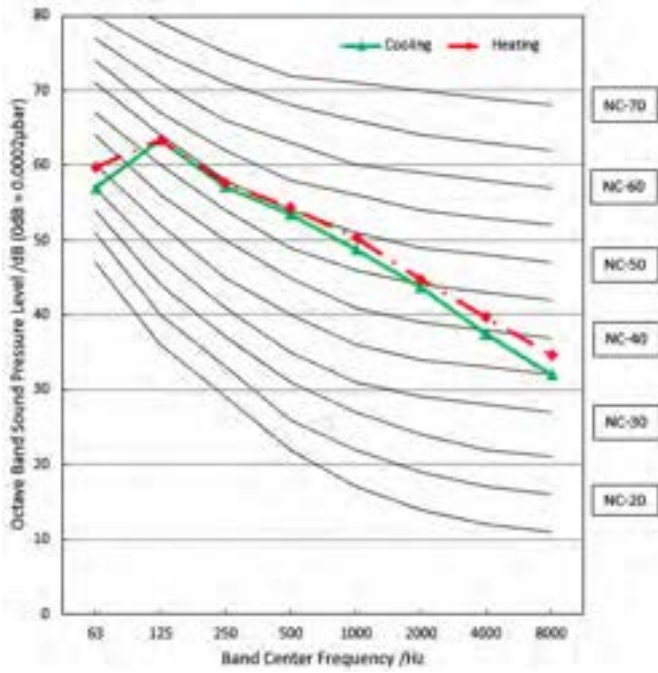

CPH24CD(O)

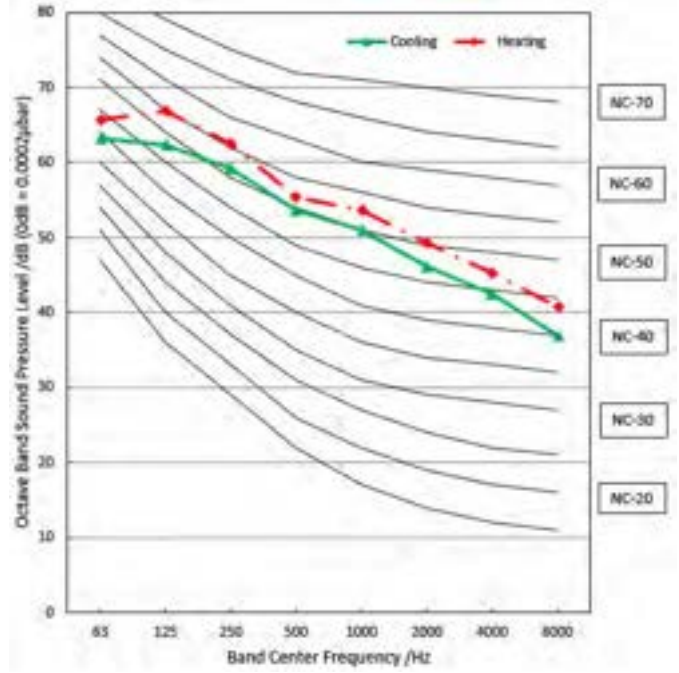

CPH30CD(O)

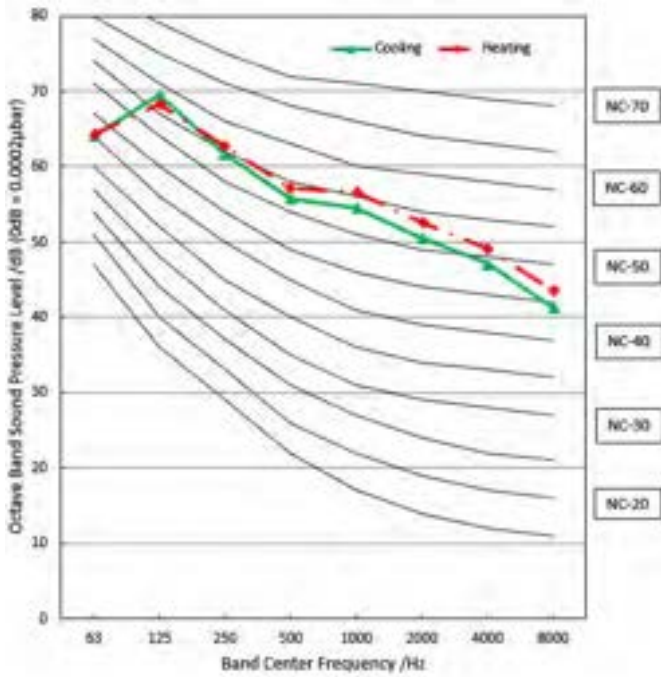

CPH36CD(O)

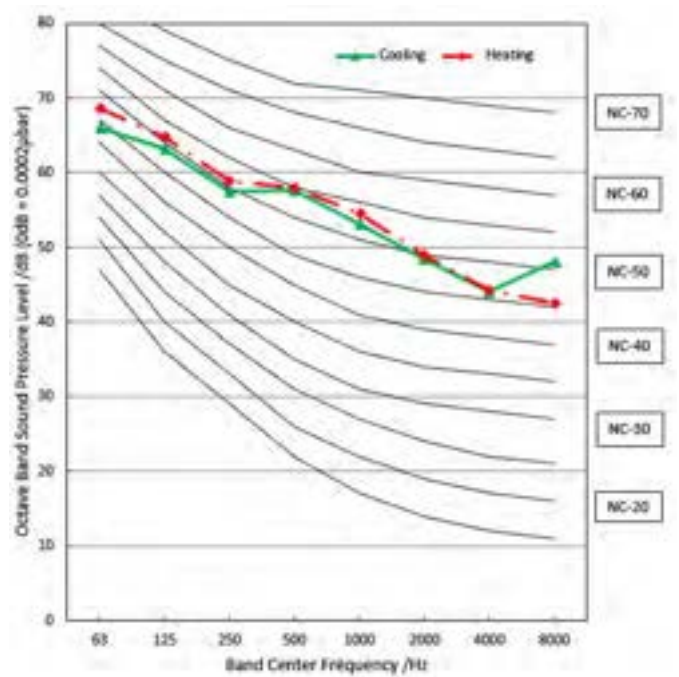

CPH48CD(O)

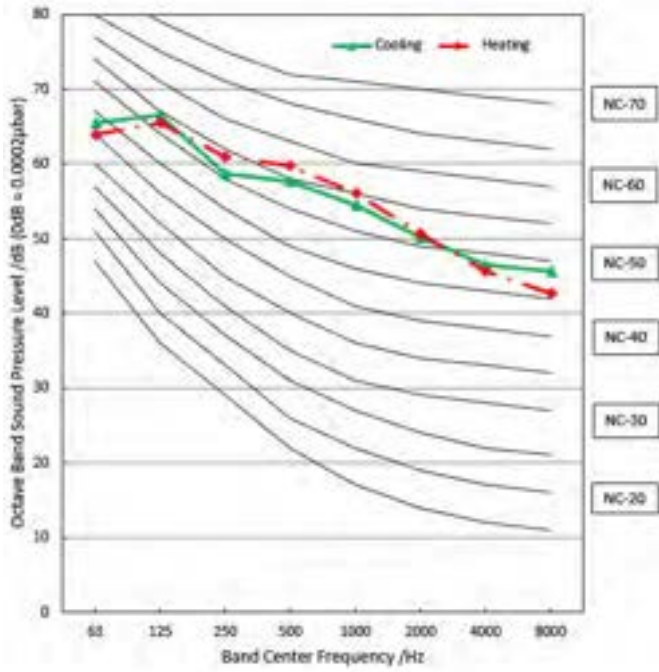

CPH60CD(O)

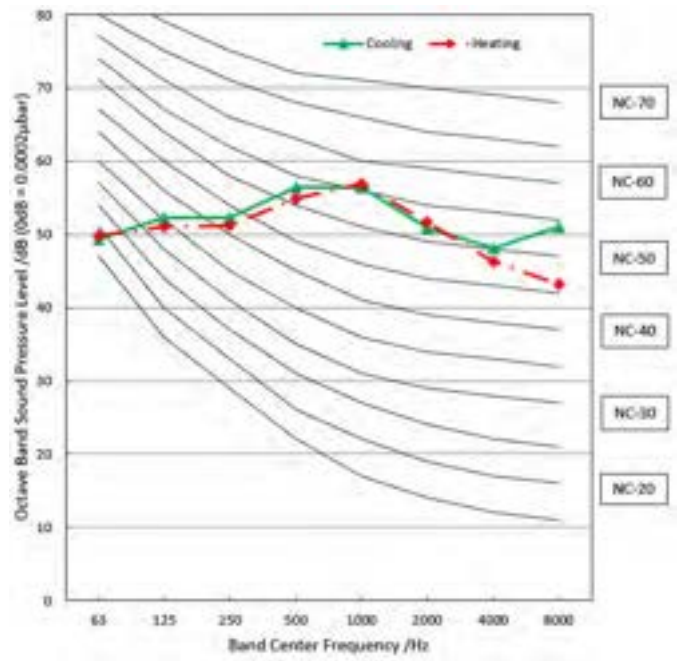

5. Refrigerant Cycle Diagrams

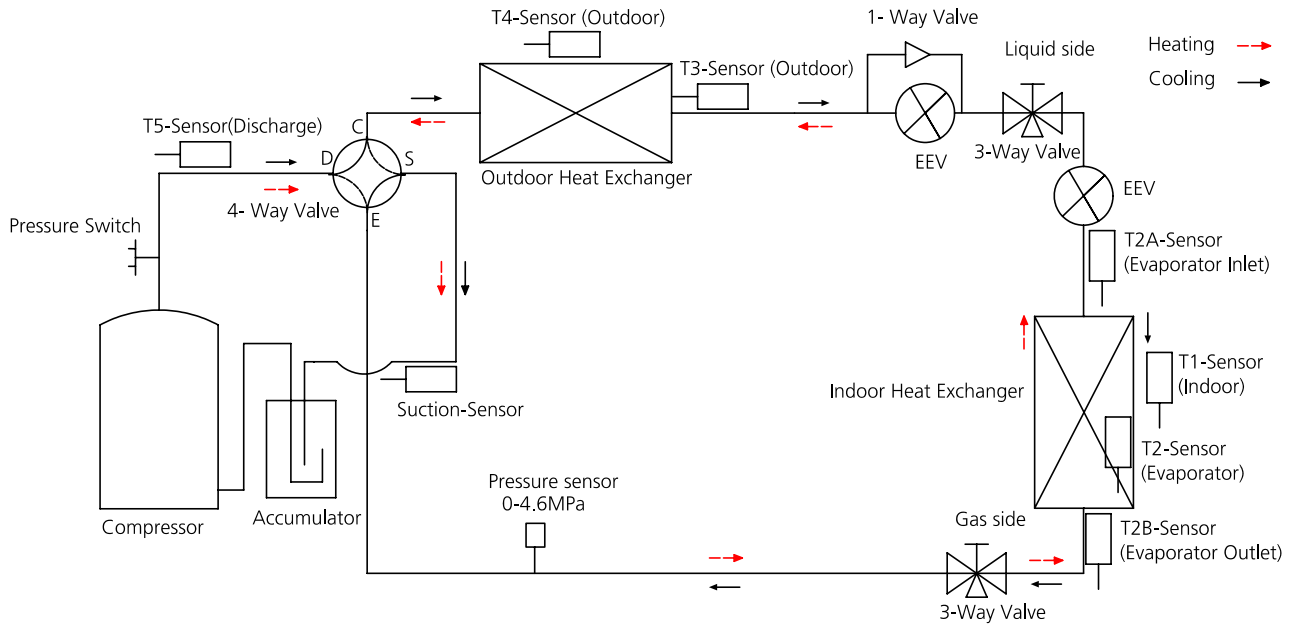

Model No.	Pipe Size (Diameter:ø) mm(inch)		Piping length (m/ft)		Elevation (m/ft)		Additional Refrigerant
	Gas	Liquid	Rated	Max.	Rated	Max.	
CPR18CD(O)	19(3/4)	9.52(3/8)	7.5/24.6	30/98.4	0	20/65.6	65g/m (0.69oz/ft)

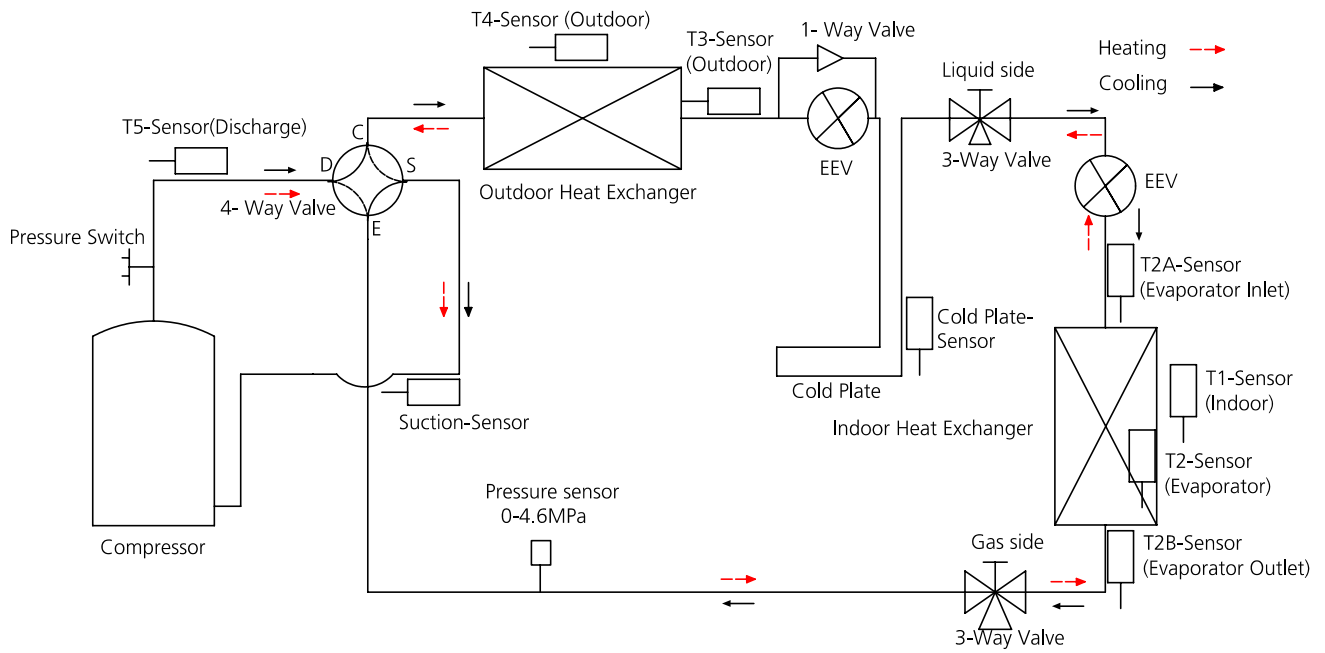

Model No.	Pipe Size (Diameter:ø) mm(inch)		Piping length (m/ft)		Elevation (m/ft)		Additional Refrigerant
	Gas	Liquid	Rated	Max.	Rated	Max.	
CPH24CD(O)	19(3/4)	9.52(3/8)	7.5/24.6	50/164	0	25/82	65g/m (0.69oz/ft)
CPR30CD(O)	19(3/4)	9.52(3/8)	7.5/24.6	50/164	0	25/82	

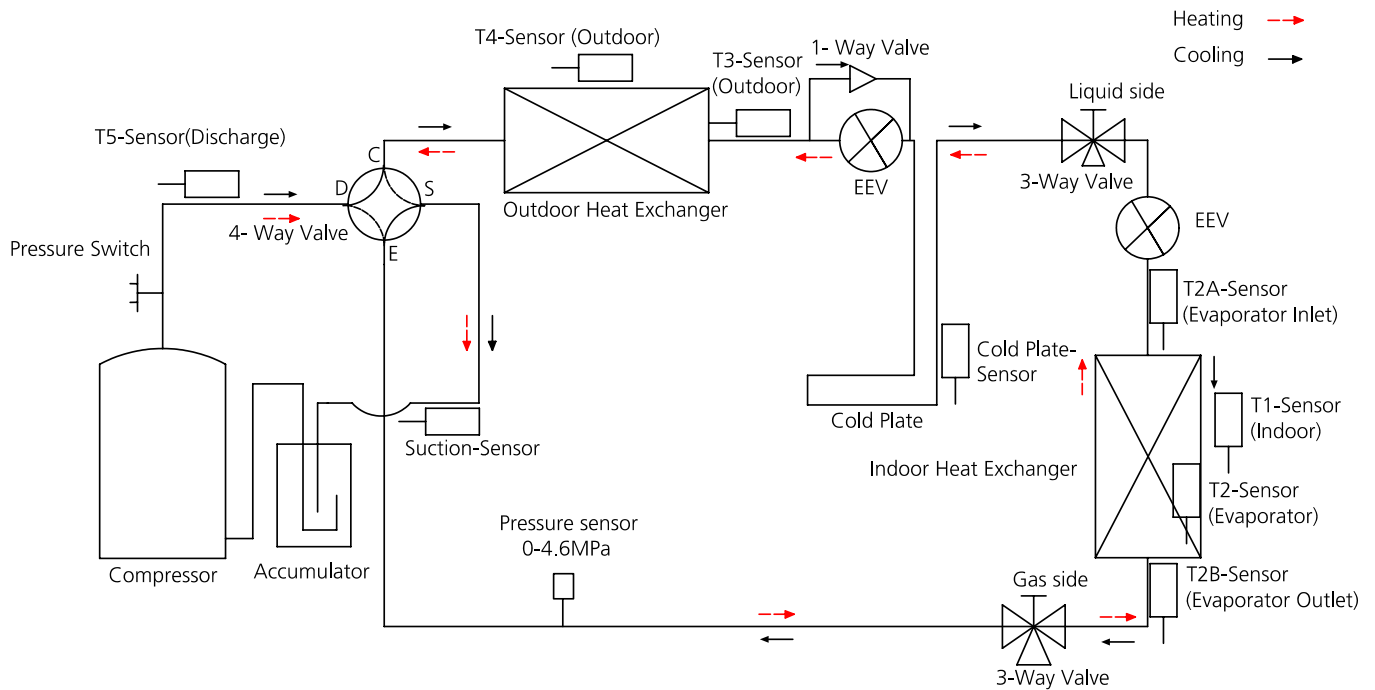

Model No.	Pipe Size (Diameter:ø) mm(inch)		Piping length (m/ft)		Elevation (m/ft)		Additional Refrigerant
	Gas	Liquid	Rated	Max.	Rated	Max.	
CPH18CD(O)	19(3/4)	9.52(3/8)	7.5/24.6	30/98.4	0	20/65.6	65g/m (0.69oz/ft)
CPR24CD(O)	19(3/4)	9.52(3/8)	7.5/24.6	50/164	0	25/82	
CPH30CD(O)	19(3/4)	9.52(3/8)	7.5/24.6	50/164	0	25/82	
CPR36CD(O)	19(3/4)	9.52(3/8)	7.5/24.6	65/213	0	30/98.4	
CPR48CD(O)	19(3/4)	9.52(3/8)	7.5/24.6	65/213	0	30/98.4	
CPR60CD(O)	22(7/8)	9.52(3/8)	7.5/24.6	65/213	0	30/98.4	

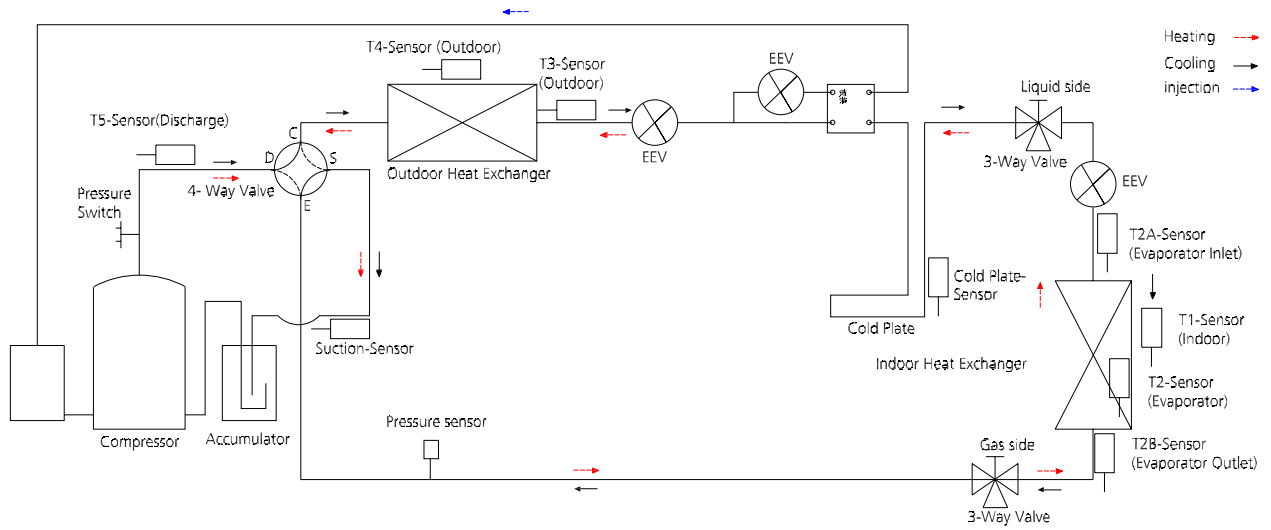

Model No.	Pipe Size (Diameter:ø) mm(inch)		Piping length (m/ft)		Elevation (m/ft)		Additional Refrigerant
	Gas	Liquid	Rated	Max.	Rated	Max.	
36K	19(3/4)	9.52(3/8)	7.5/24.6	65/213	0	30/98.4	65g/m (0.69oz/ft)

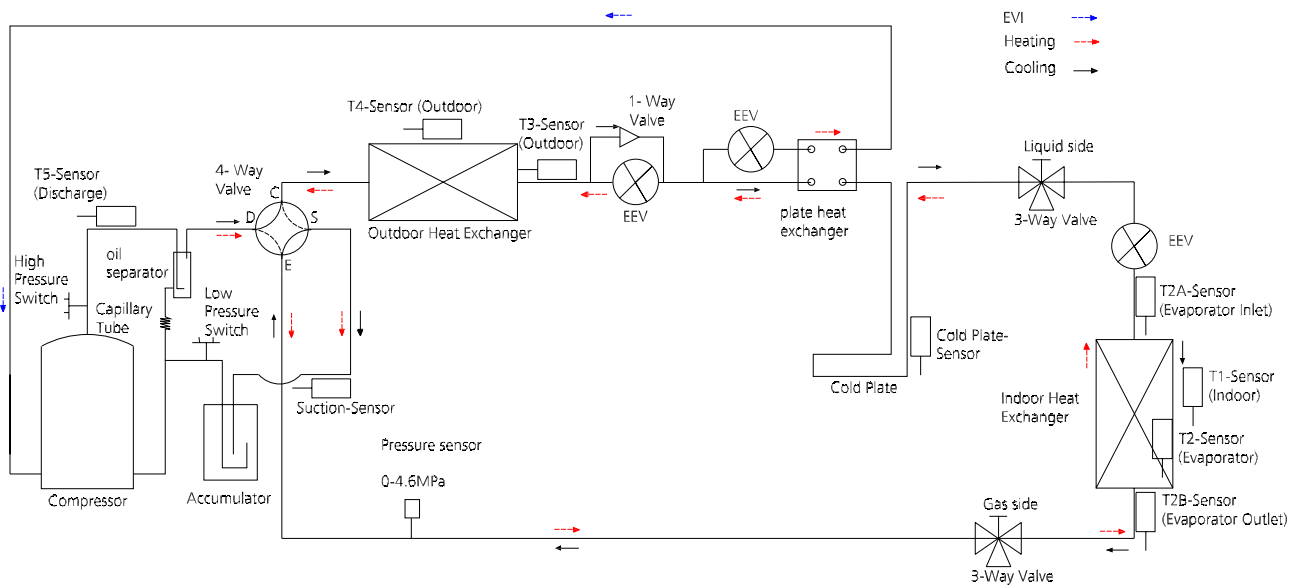

Model No.	Pipe Size (Diameter:ø) mm(inch)		Piping length (m/ft)		Elevation (m/ft)		Additional Refrigerant
	Gas	Liquid	Rated	Max.	Rated	Max.	
CPH36CD(O)	19(3/4)	9.52(3/8)	7.5/24.6	65/213	0	30/98.4	65g/m (0.69oz/ft)
CPH48CD(O)	19(3/4)	9.52(3/8)	7.5/24.6	65/213	0	30/98.4	

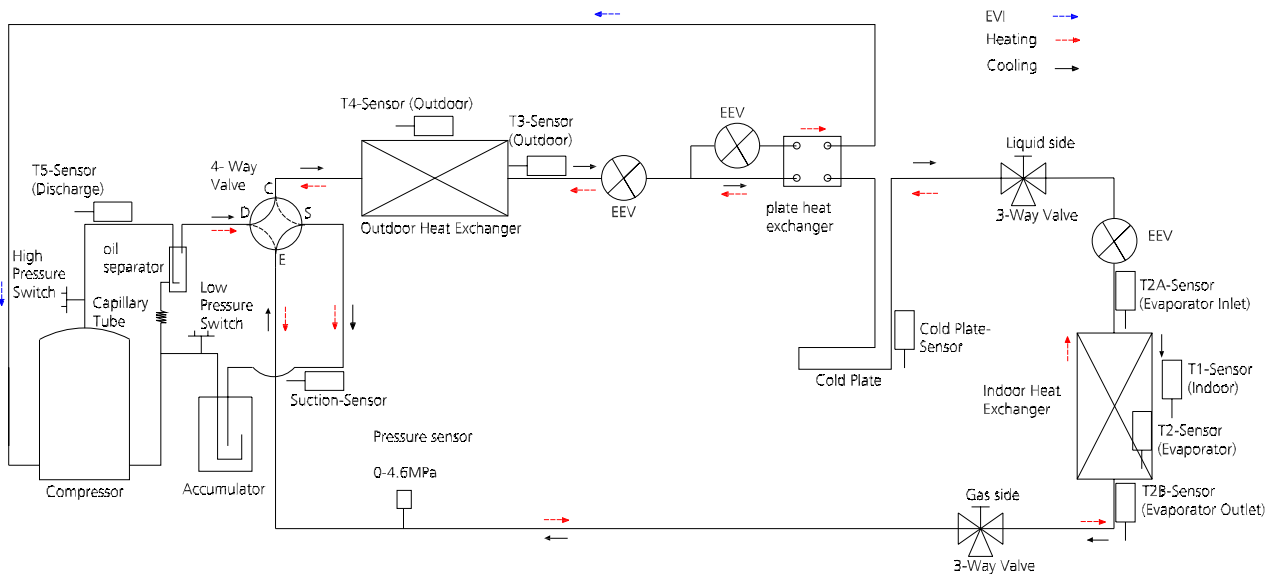

55K

Model No.	Pipe Size (Diameter:ø) mm(inch)		Piping length (m/ft)		Elevation (m/ft)		Additional Refrigerant
	Gas	Liquid	Rated	Max.	Rated	Max.	
CPH60CD(O)	22(7/8)	9.52(3/8)	7.5/24.6	65/213	0	30/98.4	65g/m (0.69oz/ft)

6. Electrical Wiring Diagrams

ODU Model	ODU Wiring Diagram
CPR18CD(O)	16022000036289
CPH18CD(O)	16022000036171
CPR24CD(O)	
CPH24CD(O)	16022000036170
CPH30CD(O)	
CPR30CD(O)	
CPR36CD(O)	
CPH36CD(O)	16022000036969
CPH48CD(O)	
CPH60CD(O)	
CPR48CD(O)	16022000036169
CPR60CD(O)	

ODU Model	ODU Main Printed Circuit Board	Inverter Module Printed Board	24V Printed Board
CPR18CD(O)	17122000046453	/	17122000054047
CPH18CD(O)	17122000048064	/	17122000054047
CPR24CD(O)			
CPH24CD(O)	17122000047742	/	17122000054047
CPH30CD(O)			
CPR30CD(O)			
CPR36CD(O)			
CPH36CD(O)	17122000037804	17122000042012	17122000054047
CPH48CD(O)			
CPR48CD(O)			
CPH60CD(O)			
CPR60CD(O)			

WIRING DIAGRAM

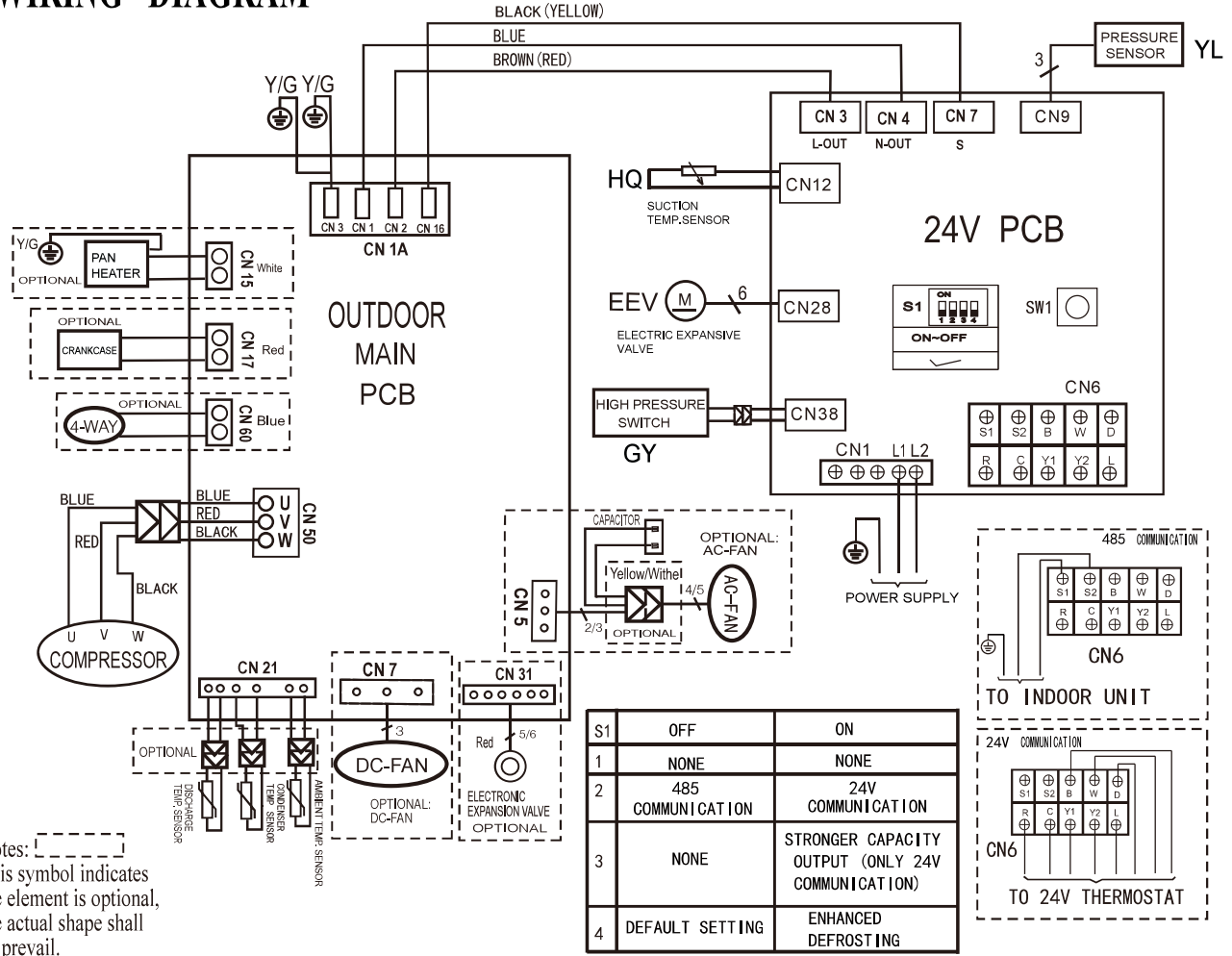

Outdoor unit wiring diagram:16022000036170

16022000036170

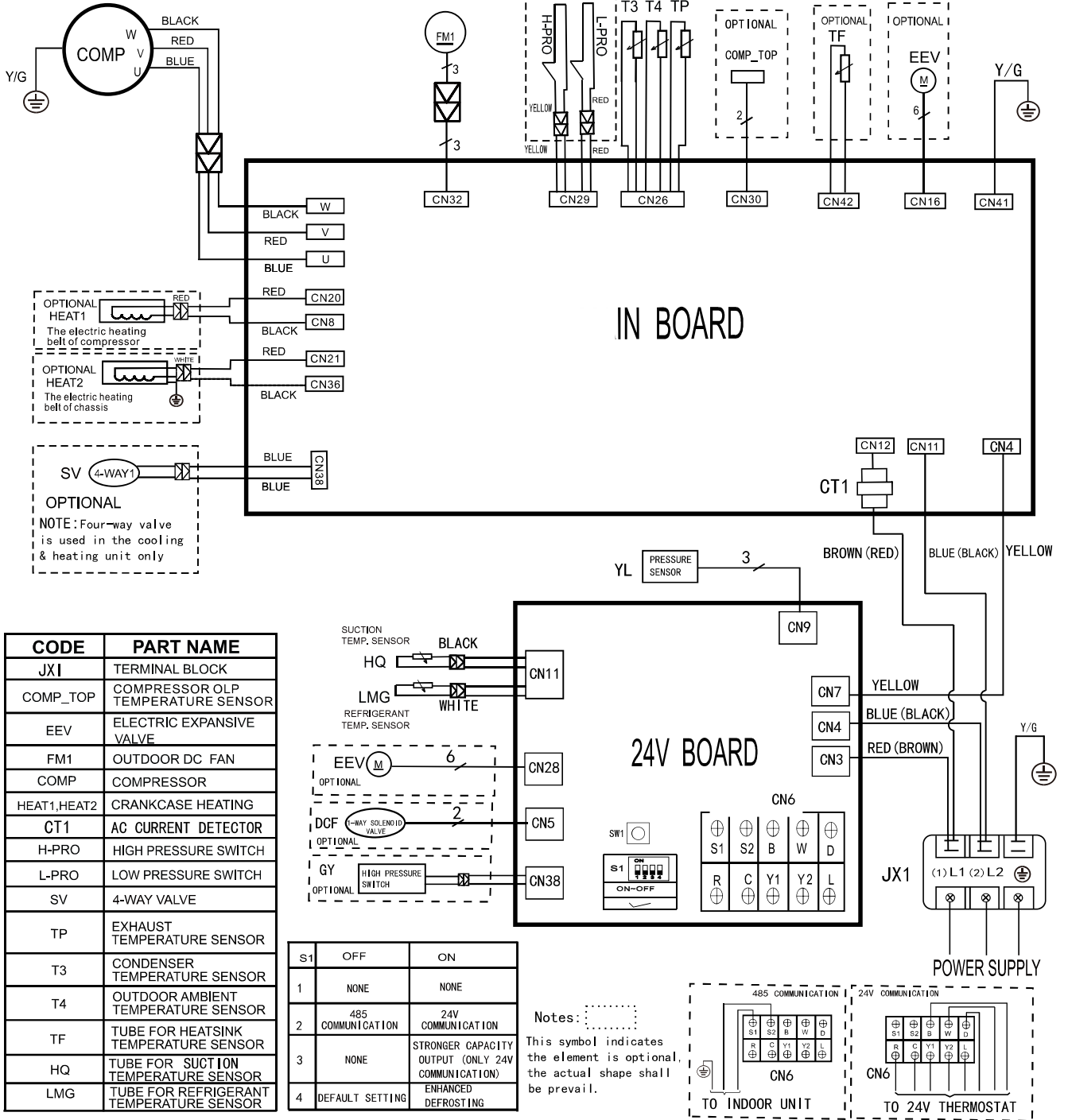

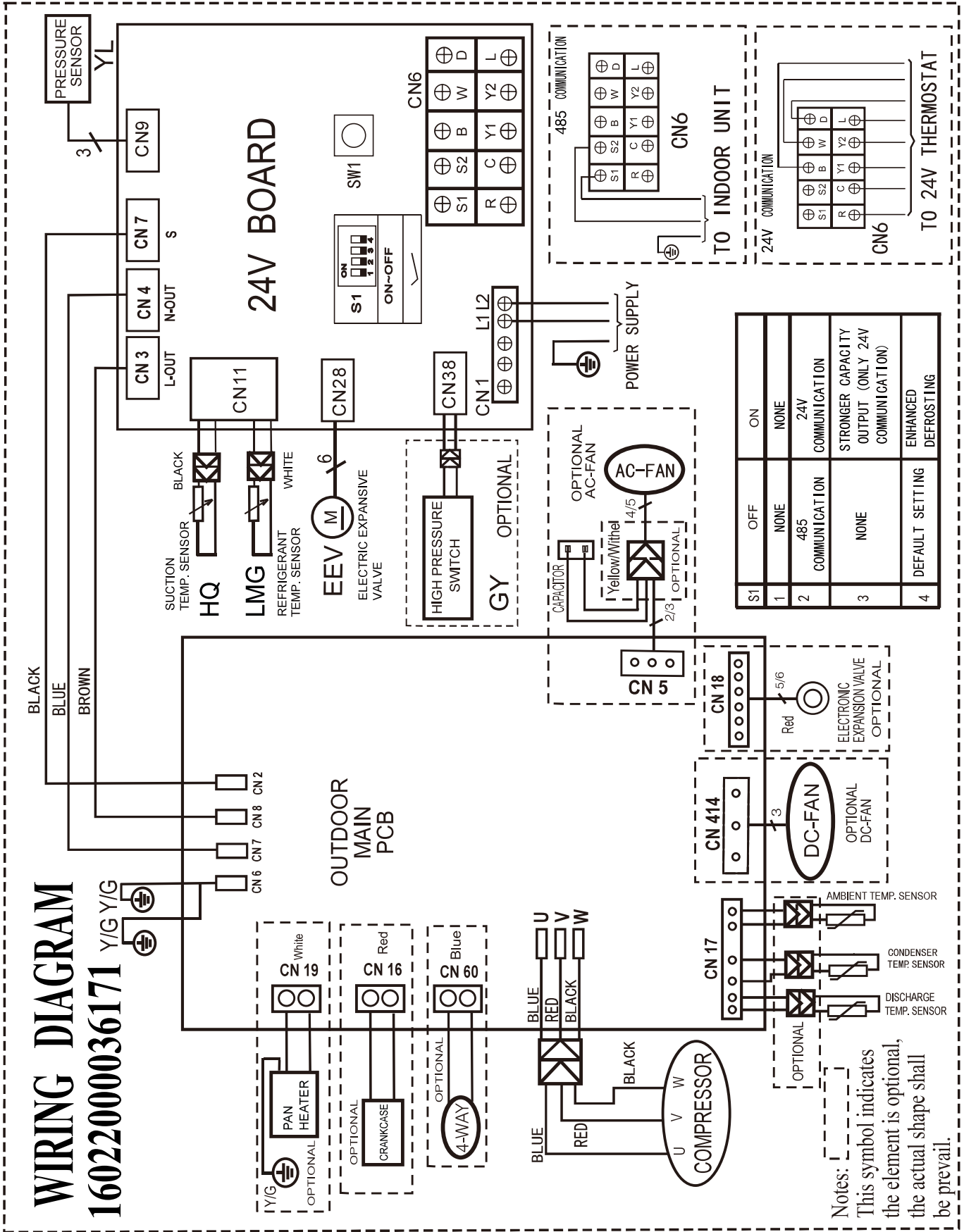

Outdoor unit wiring diagram:16022000036169

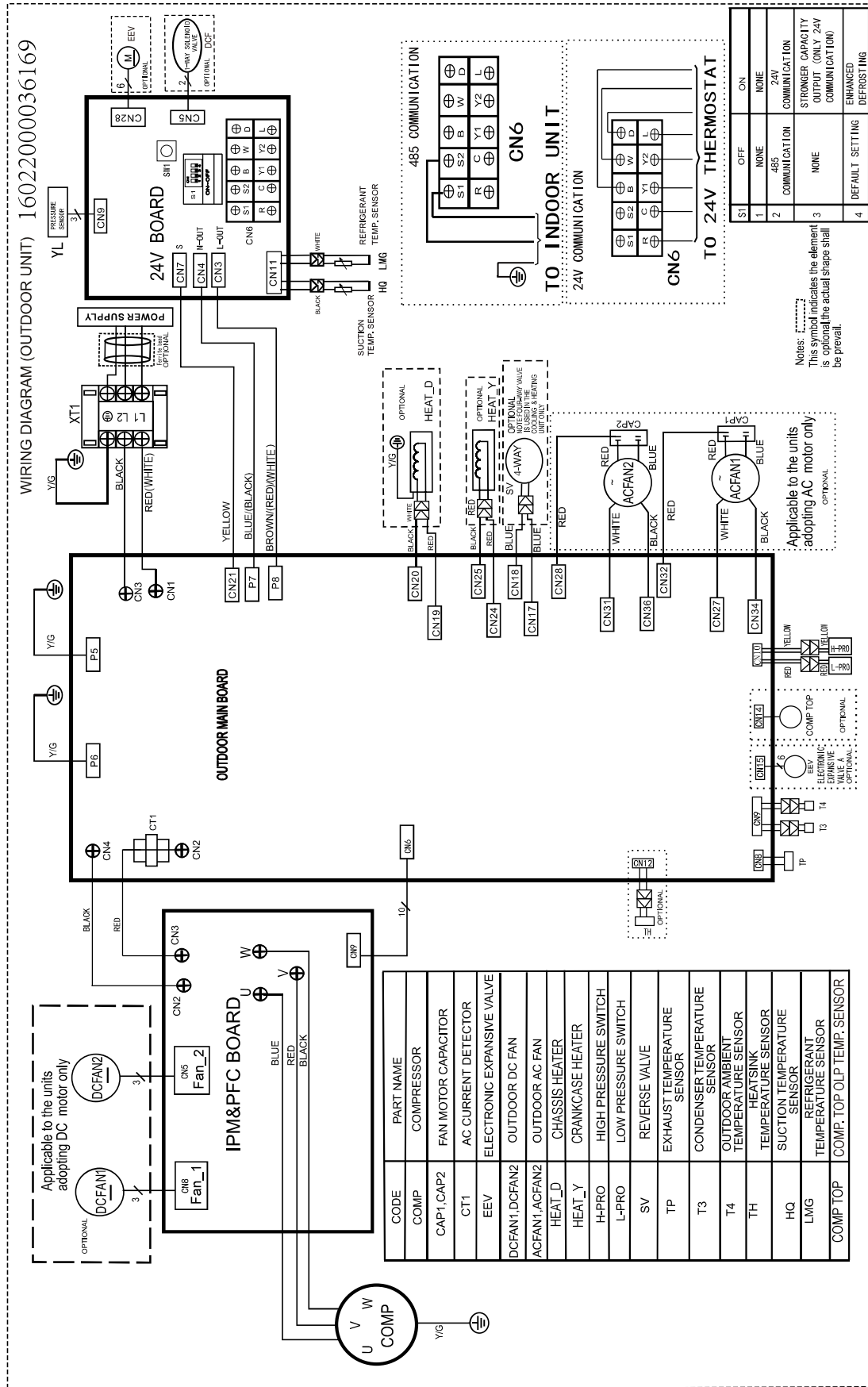

Outdoor unit wiring diagram:16022000036969

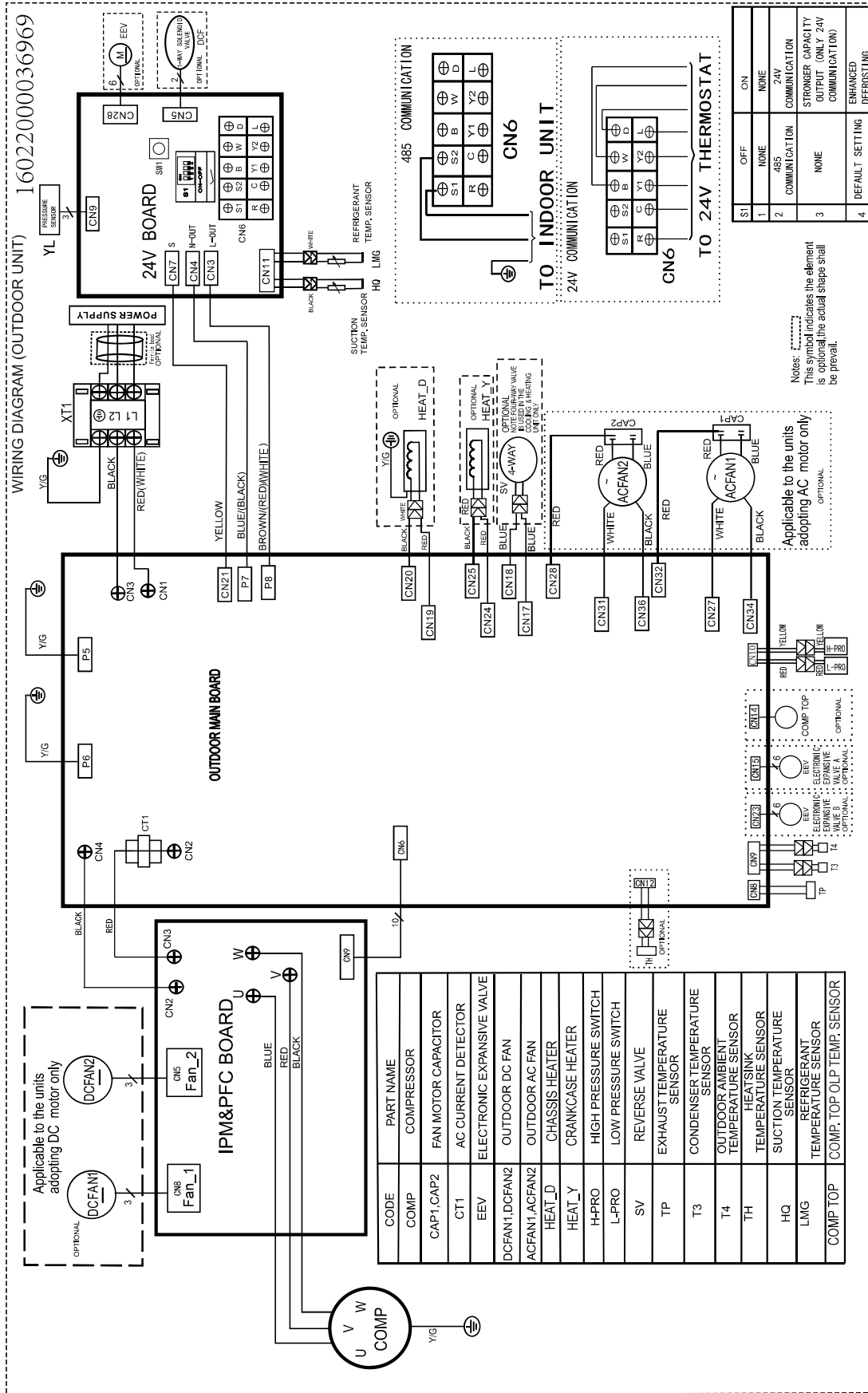

Outdoor unit wiring diagram:16022000040551

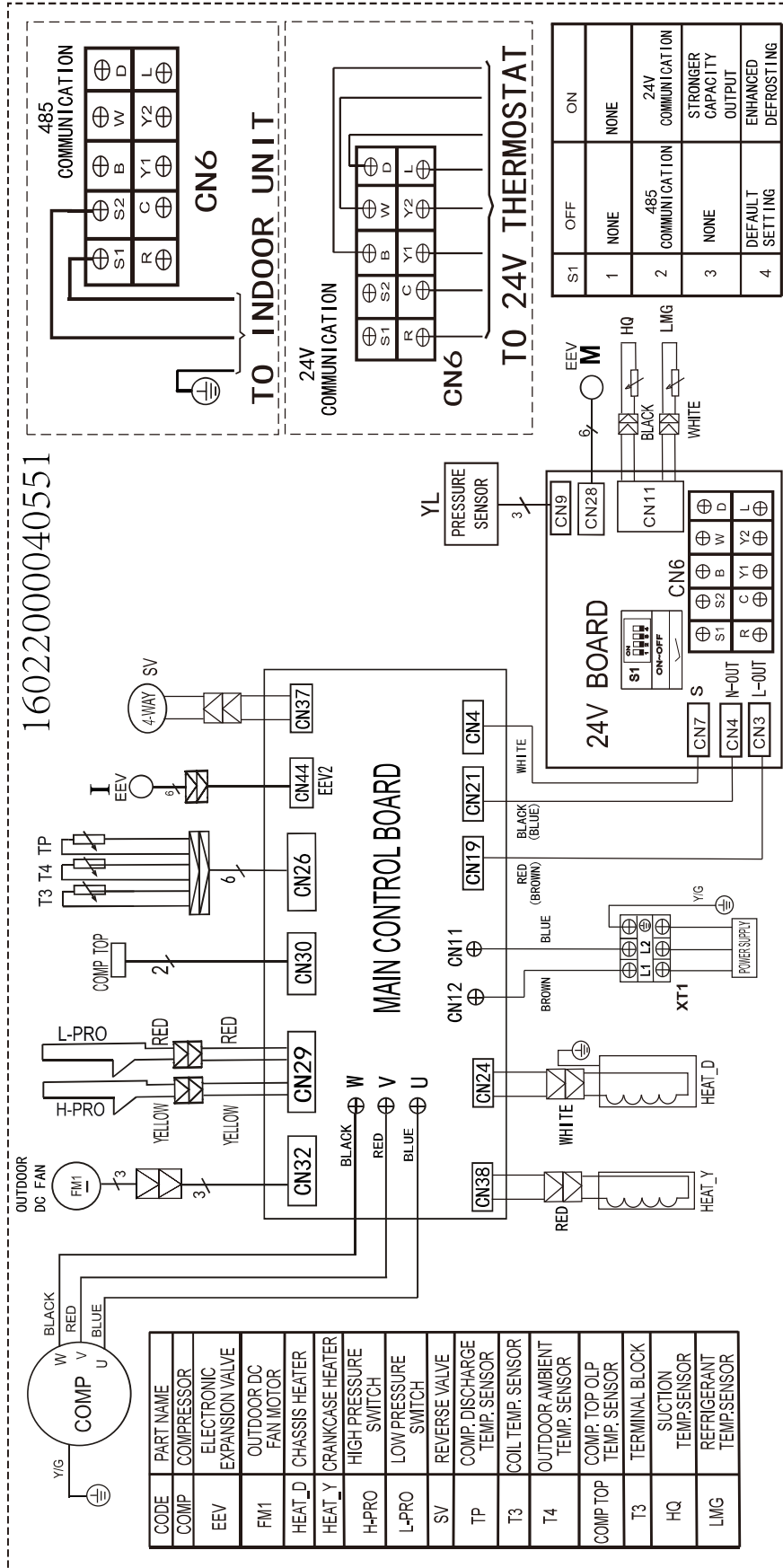

No.	Name	CN#	Meaning
1	CN1A	CN3	Earth: connect to Ground
		CN1	N_in: connect to N-line (208-230V AC input)
		CN2	L_in: connect to L-line (208-230V AC input)
		CN16	S: connect to indoor unit communication
2	HEAT1	CN17	connect to compressor heater, 208-230V AC when is ON
3	4-WAY	CN60	connect to 4 way valve, 208-230V AC when is ON.
4	HEAT2	CN15	connect to chassis heater, 208-230V AC when is ON
5	AC-FAN	CN25	connect to AC fan
6	PMV	CN31	connect to Electric Expansion Valve
7	TESTPORT	CN6	used for testing
8	TP T4 T3	CN21/CN22	connect to pipe temp. sensor T3, ambient temp. sensor T4, exhaust temp. sensor TP
9	DC-FAN	CN7	connect to DC fan
10	FAN_IPM	IPM 501	IPM for DC fan
11	W	CN28	connect to compressor
	V	CN29	0V AC (standby)
	U	CN30	10-200V AC (running)
12	COMP_IPM	IPM 301	IPM for compressor

Note: This section is for reference only. Please take practicality as standard.

Outdoor unit printed circuit board diagram: 17122000048064_17122000048066

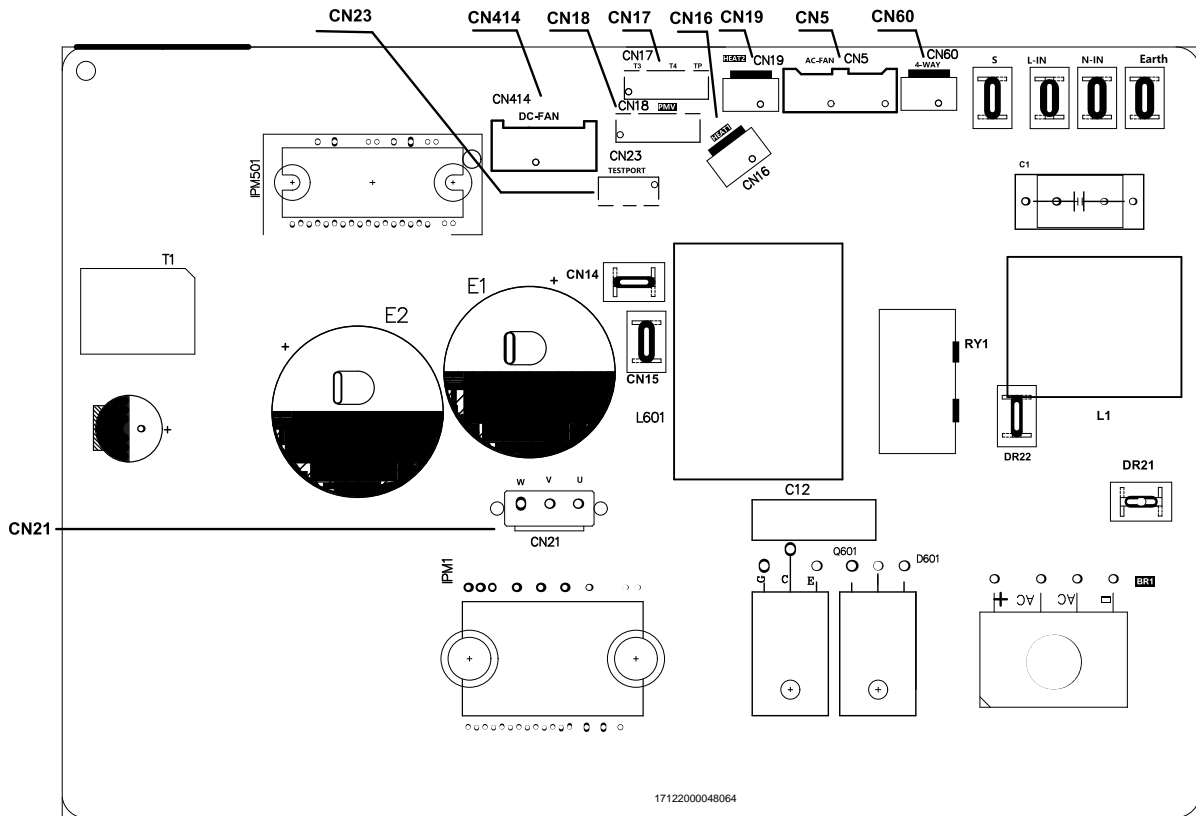

Port	Description	Parameter
CN23	Port for test board	5V/DC
CN414	Port for DC fan	0-310V/AC
CN18	Power output for electronic expansion valve	12V/DC
CN17	Power output for condenser (T3), ambient (T4) and discharge (Tp) temperature sensors	5V/DC
CN16	Power output for compressor heater	230V/AC
CN19	Power output for chassis heater	230V/AC
CN5	Power output for AC fan	230V/AC
CN60	Power output for 4-way valve	230V/AC
CN21	Port for compressor	0-310V/AC

Note: This pictures are only for reference, actual appearance may vary.

Outdoor unit printed circuit board diagram: 17122000047742

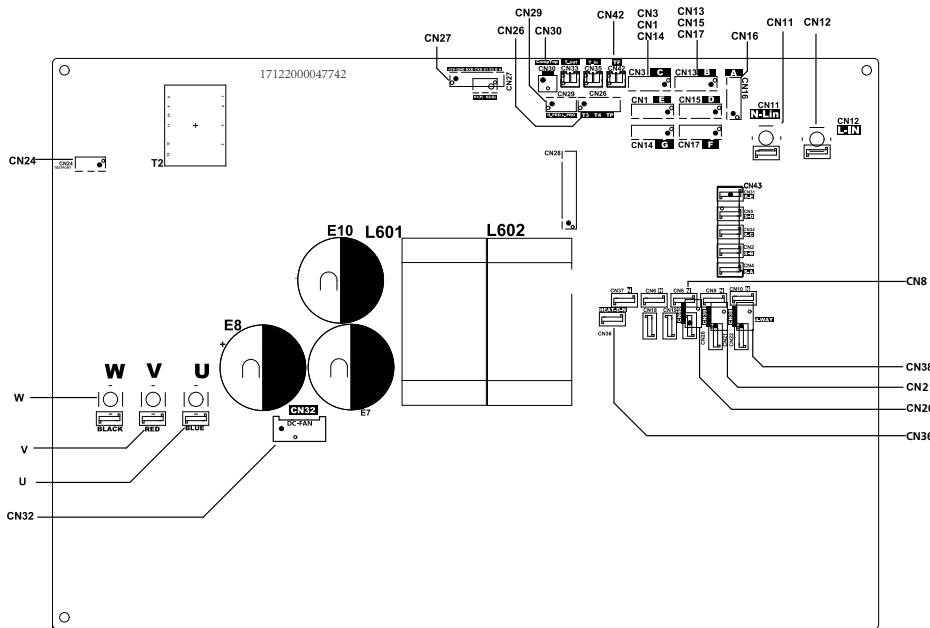

Port	Description	Parameter
CN27	Communication port with key board	
CN26	Power output for condenser (T3), ambient (T4) and discharge (Tp) temperature sensors	5V/DC
CN29	Port for High-pressure and low-pressure switches	
CN30	Port for OLP (compressor top)	
CN42	Power for heatsink (TF) temperature sensor	5V/DC
CN3,CN1, CN14, CN13, CN15,CN17	Power output for electronic expansion valve	12V/DC
CN11,12	Port for power cable (N, L)	230V/AC
CN43	S:Port for indoor unit communication	pin1-pin2: 24VDC Pulse wave; pin2-pin3: 208-230V AC input
CN38	Power output for 4-way valve	230V/AC
CN21,CN36	Power output for chassis heater	230V/AC
CN8,CN20	Power output for compressor heater	230V/AC
CN24	Port for test board	5V/DC
UVW	Port for compressor	0-310V/AC
CN32	Port for DC fan	0-310V/AC

Note: This pictures are only for reference, actual appearance may vary.

Outdoor unit printed circuit board diagram: 17122000037804

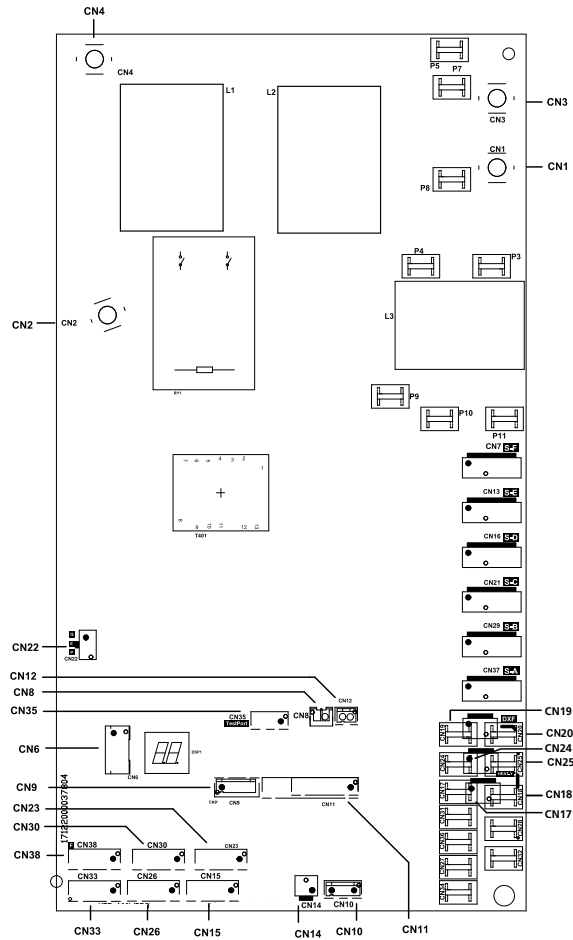

Port	Description	Parameter
CN2/CN4	Power output for IPM board	230V/AC
CN22	Port for communication with indoor unit	
CN12	Power output for IPM heat sink (TH) temperature sensor	5V/DC
CN8	Power output for discharge (TP) temperature sensor	5V/DC
CN35	Port for test board	5V/DC
CN6	Port for communication with IPM board	5V/DC
CN9	Power output for condenser (T3), ambient (T4) temperature sensors	5V/DC
CN15/CN23/CN26 CN30/CN34/CN38	Power output for EEV(A~F)	12V/DC
CN14	Power output for compressor top temperature sensor	5V/DC
CN10	Port for Hi-pressure and low-pressure switches	
CN11	Power output for pipe temp. sensor T2B	5V/DC
CN17/CN18	Power output for 4-way valve	230V/AC
CN24/CN25	Power output for compressor heater	230V/AC
CN19/CN20	Power output for chassis heater	230V/AC
CN1/CN3	Power input of the PCB	230V/AC

Note: This section is for reference only. Please take practicality as standard.

Outdoor unit IPM board diagram: 17122000042012

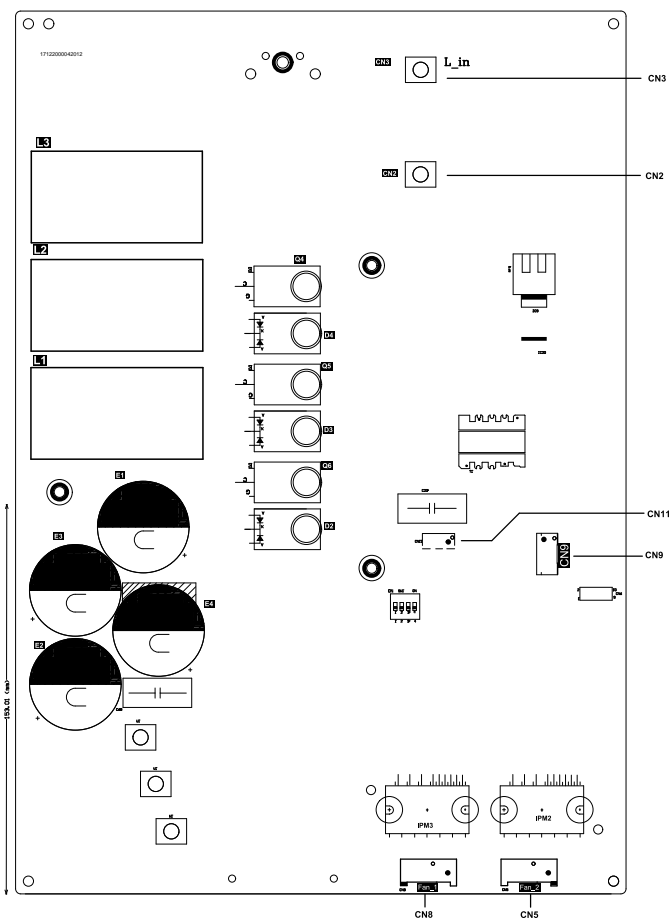

Port	Description	Parameter
CN3	N-in	
CN2	L-in	220V-240V/AC
CN11	Port for test board	5V/DC
CN9	Communication port with main board	5V/DC
CN5, CN8	Ports for DC fan motor	0-310V/AC
U, V, W	Output for compressor	0-310V/AC

Note: This section is for reference only. Please take practicality as standard.

Outdoor unit printed circuit board diagram: 17122300007152

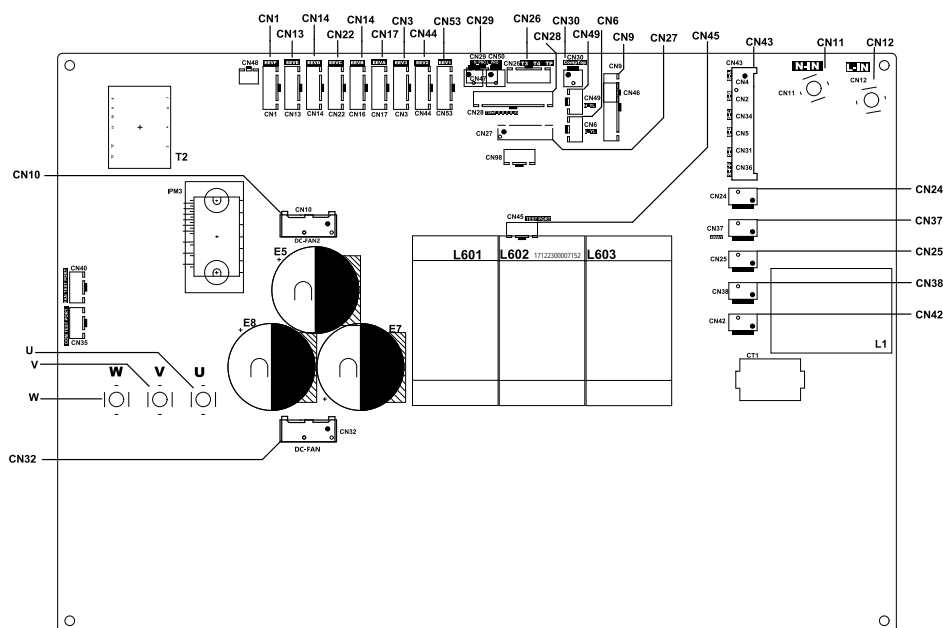

Port	Description	Parameter	Port	Description	Parameter
CN1, CN13, CN14, CN22, CN16, CN17, CN3, CN44, CN53	Power output for electronic expansion valve	12V/DC	CN43	Communication ports to indoor unit (S for A-F)	Input: 0~230V/AC
CN29	Port for high-pressure and low-pressure switches	Input: 5V/DC	CN11,12	Power input for this PCB	230V/AC
CN26	Power output for condenser(T3), ambient (T4) and discharge(TP) temperature sensors	5V/DC	CN24	Power output for chassis heater	230V/AC
CN28	Power output for evaporator (T2B) temperature sensor of IDU A-F	5V/DC	CN37	Power output for 4-way valve 1	230V/AC
CN30	Port for compressor top high temperature protector	Input: 5V/DC	CN25	Power output for 4-way valve 2	230V/AC
CN49/CN6	Port for Hi-pressure and low-pressure sensors	5V/DC	CN38	Power output for compressor heater	230V/AC
CN9	Power output for EVI temperature sensors (T5-T8)	5V/DC	CN42	Power output for 4-way valve 3	230V/AC
CN27	Communication port with key board	5V/DC	U, V, W	Output for compressor	0-310V/AC
CN45	Port for DR module (Test port)	5V/DC	CN32/CN10	Output for DC fan	0-310V/AC

Note: This pictures are only for reference, actual appearance may vary.

Outdoor unit printed circuit board diagram: 17122000054047

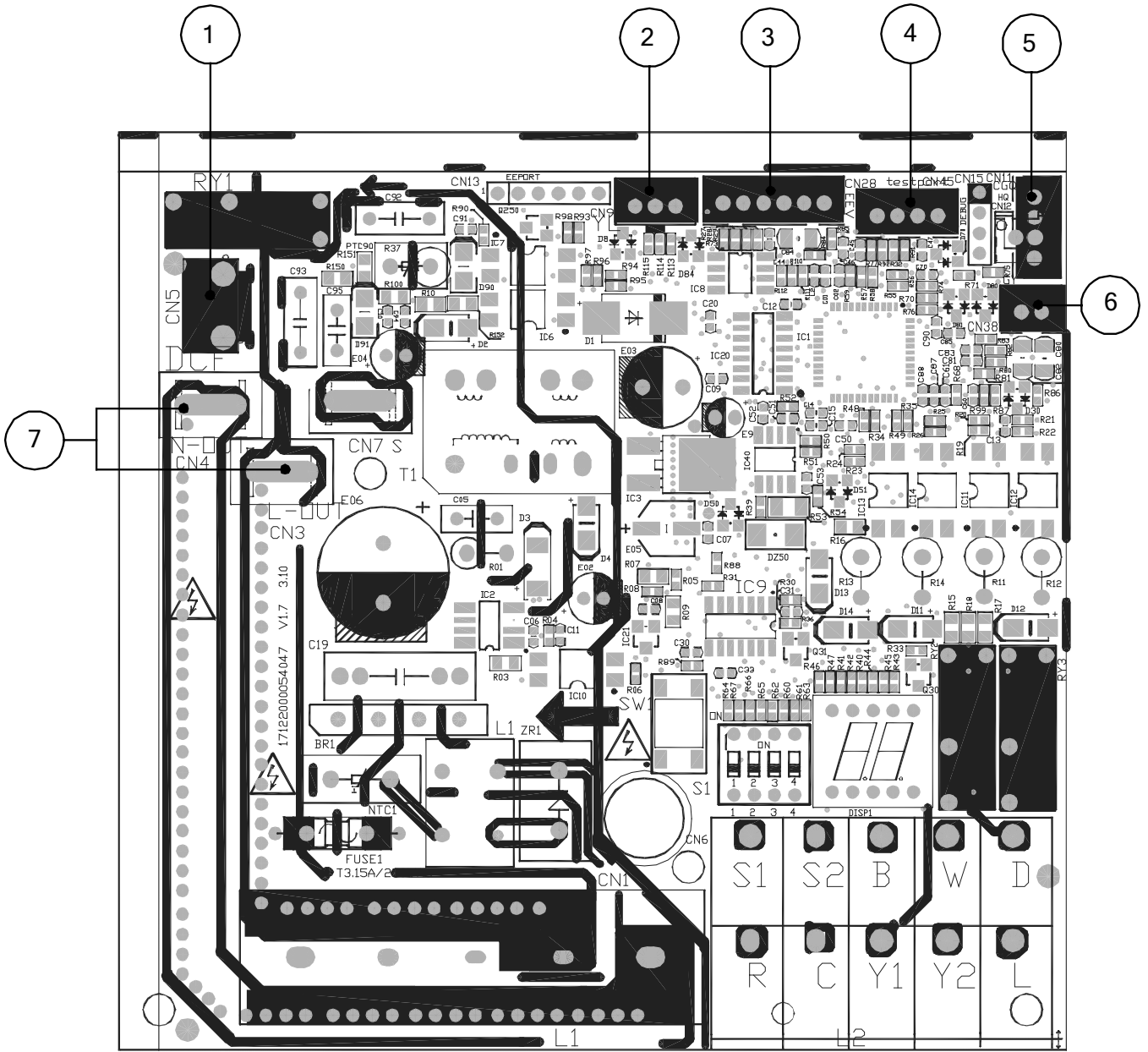

No.	Name	CN#	Meaning
1	/	CN5	connect to one-way solenoid valve
2	/	CN9	connect to pressure sensor (5VDC)
3	/	CN28	connect to electric expansion valve (12VDC)
4	TESTPORT	CN45	used for testing (5VDC)
5	/	CN11	connect to suction temp. sensor, cold plate temp. sensor (5VDC)
6	H-PRO	CN38	connect to high pressure switch (5VDC)
7	Power Supply	CN3	connect to main board L-Out
		CN4	connect to main board N-Out

Note: This section is for reference only. Please take practicality as standard.

Installation

Contents

1. Installation Overview
2. Location Selection
3. Indoor Unit Installation
4. Outdoor Unit Installation
5. Drainage Pipe Installation
6. Refrigerant Pipe Installation
7. Vacuum Drying and Leakage Checking
8. Additional Refrigerant Charge
9. Engineering of Insulation
10. Engineering of Electrical Wiring
11. Test Operation

1. Installation Overview

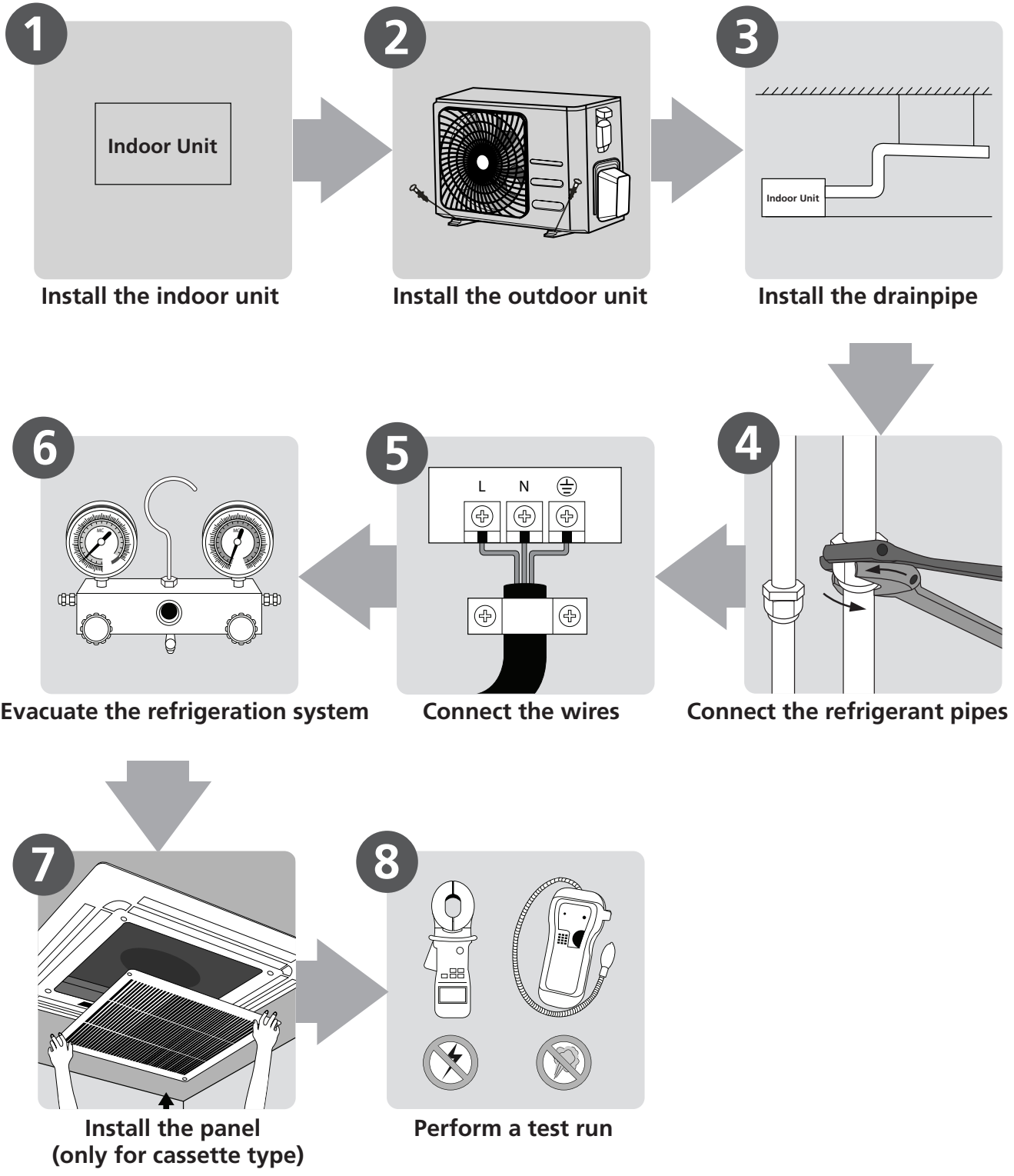

2. Location selection

2.1 Unit location selection can refer to installation manual.

2.2 DO NOT install the unit in the following locations:

- Where oil drilling or fracking is taking place.
- Coastal areas with high salt content in the air.
- Areas with caustic gases in the air, such as near hot springs.
- Areas with power fluctuations, such as factories.
- Enclosed spaces, such as cabinets.
- Areas with strong electromagnetic waves.
- Areas that store flammable materials or gas.
- Rooms with high humidity, such as bathrooms or laundry rooms.
- If possible, DO NOT install the unit where it is exposed to direct sunlight.

2.3 Rows of series installation

The relations between H, A and L are as follows.

	L	A
L ≤ H	$L \leq 1/2H$	25 cm / 9.8" or more
	$1/2H < L \leq H$	30 cm / 11.8" or more
L > H	Can not be installed	

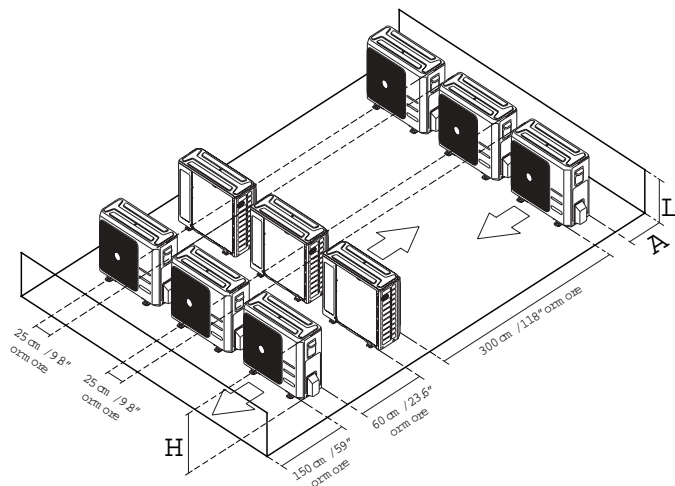

DO NOT install the rows of series like following figure.

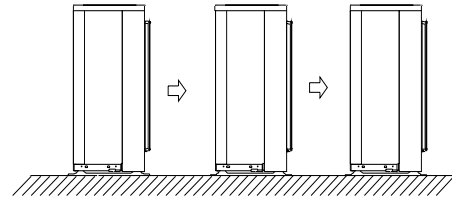

2.4 If the unit is exposed to heavy wind:

- Install unit so that air outlet fan is at a 90° angle to the direction of the wind. If needed, build a barrier in front of the unit to protect it from extremely heavy winds.

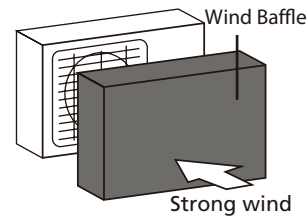
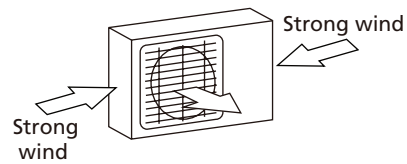

2.5 If the unit is frequently exposed to heavy rain or snow:

Build a shelter above the unit to protect it from the rain or snow. Be careful not to obstruct air flow around the unit.

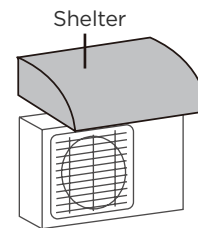

2.6 If the unit is frequently exposed to salty air (seaside):

Use outdoor unit that is specially designed to resist corrosion.

3. Indoor Unit Installation(AHU)

3.1 Service space for indoor unit

Horizontal installation

Plenum Clearances:

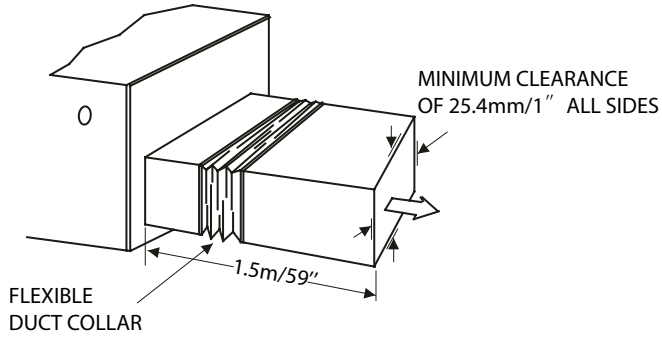

Vertical installation

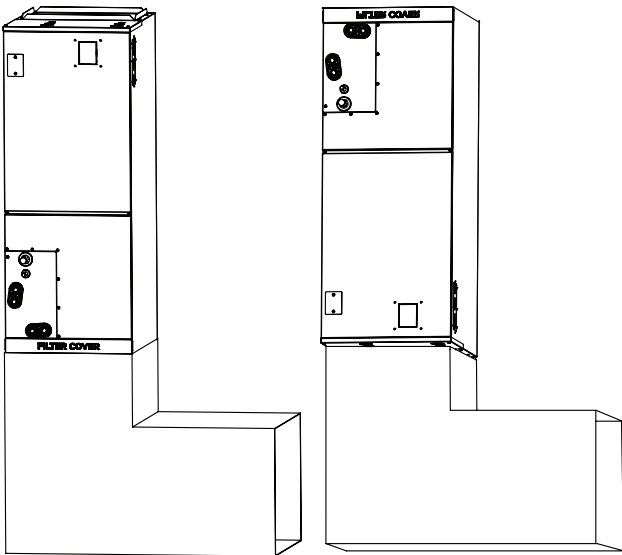

When installed vertically (upward or downward), the lower end of the air outlet needs to be connected to the L-shaped metal air duct and fastened by screws.

3.2 Installation place

Vertical installation

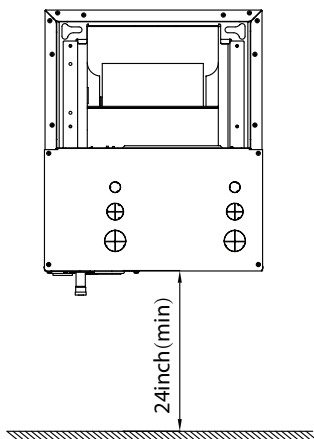

Horizontal installation

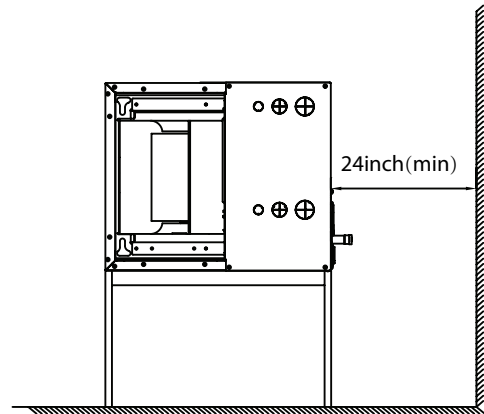

3.2 Install the main body

The unit may be installed in one of the upflow, downflow, horizontal left or horizontal right orientations.

Vertical installation

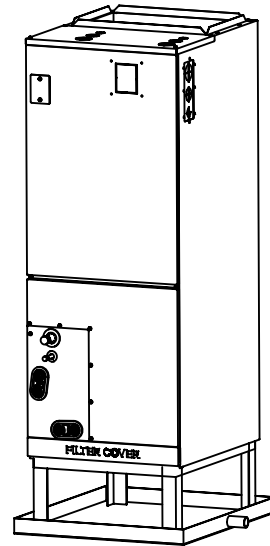

Horizontal installation

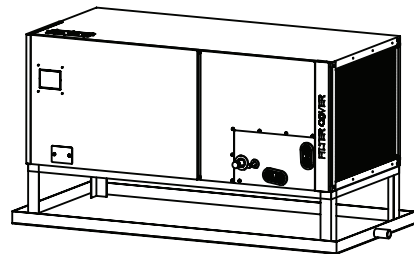

NOTE: For installation, an drain pan(not supplied) must be installed.

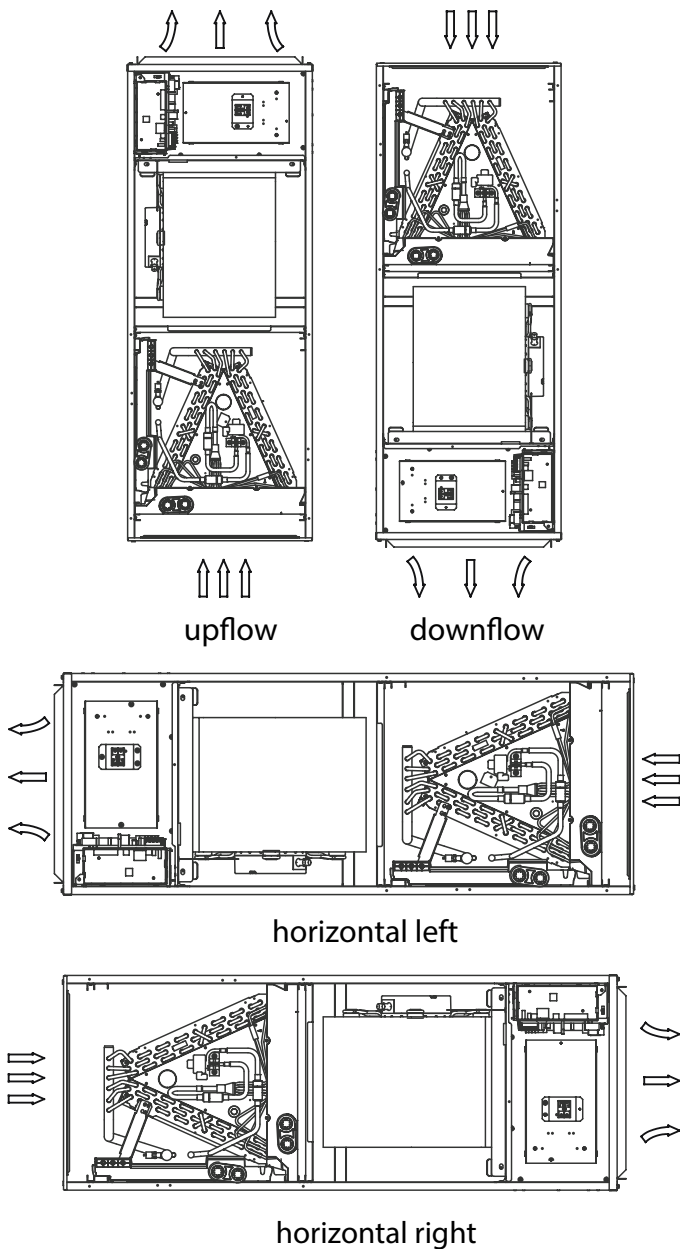

For the Horizontal left installation and vertical down installation, the direction of the evaporator should be changed and the drain pan should be removed first. Please do it according to the following steps:

1. Remove the fixed plate of the filter ,then take the filter off.

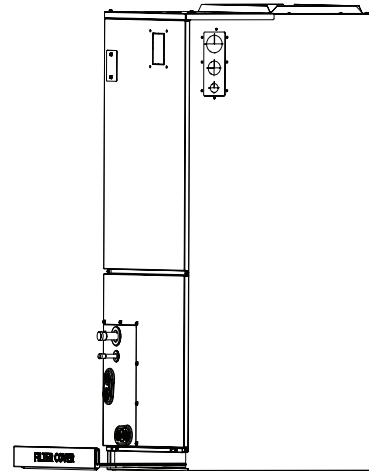

2. Remove the upper cover assembly.

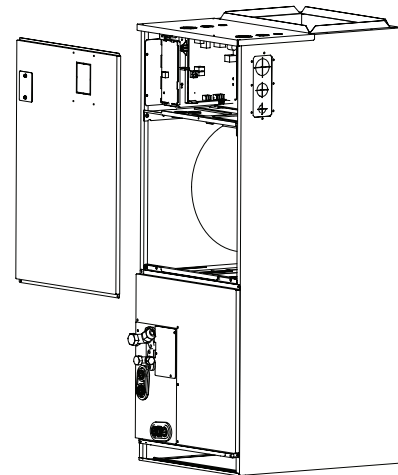

3. Remove evaporator cover plate.

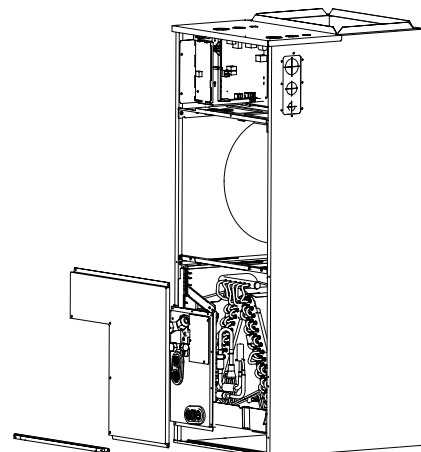

Note: Vertical up and horizontal left installation does not need to change the direction of evaporator.

Regular installation instructions

Please follow these steps to perform Vertical up installation and Horizontal left installation:

1. Open the upper cover.
2. Open the cover of the electronic control box.
3. Connect the wire according to the wiring diagram.
4. Connect the pipes.
5. Install the drainage pipes

Reversing installation instructions

4. Unplug temperature sensors T1,T2,T2A,T2B and electronic expansion valve(EEV) from the control board.

T1: Room temperature sensor

T2: Evaporator central temperature sensor

T2A: Evaporator input temperature sensor(only available for some models)

T2B: Evaporator output temperature sensor(only available for some models)

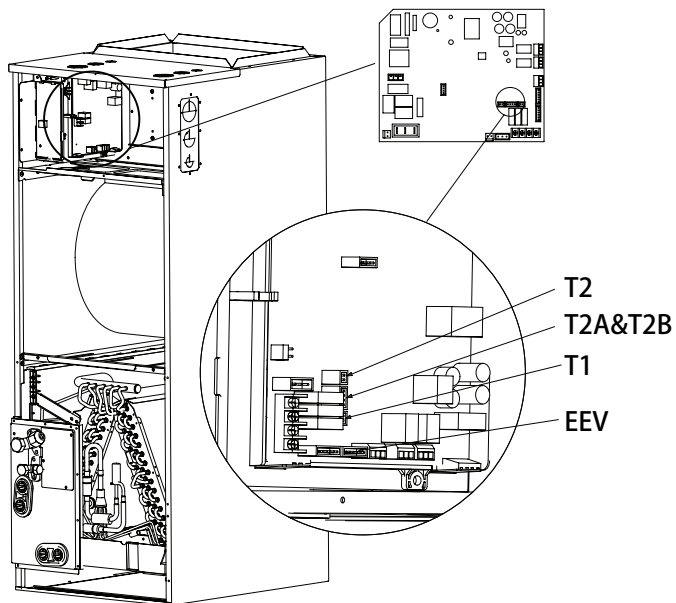

5. Remove T1,T2,T2A,T2B sensor,EEV wire ties.

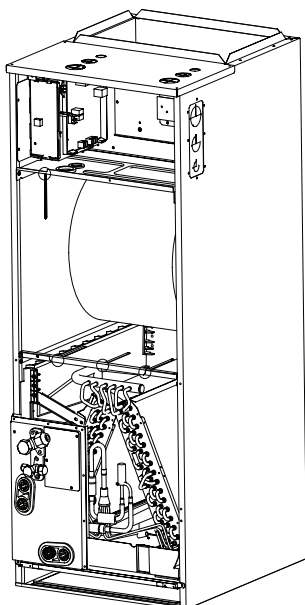

6. Take out the evaporator and drain pan and rotate 180°.

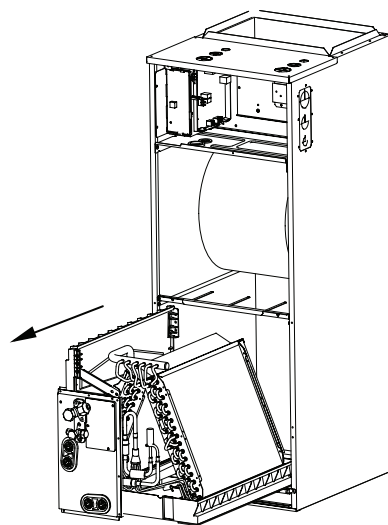

7. Adjust the position of the mounting parts.

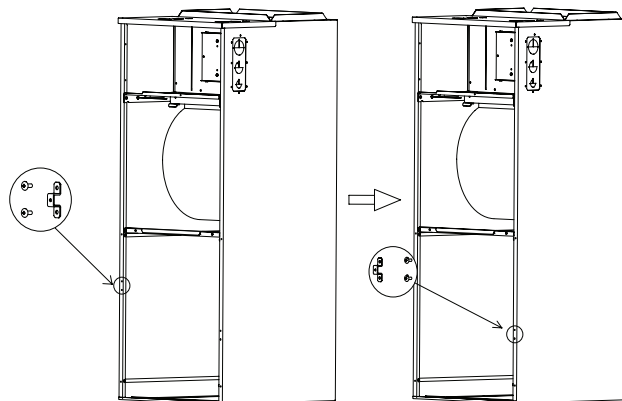

8. Reinstall the evaporator and drain pan.

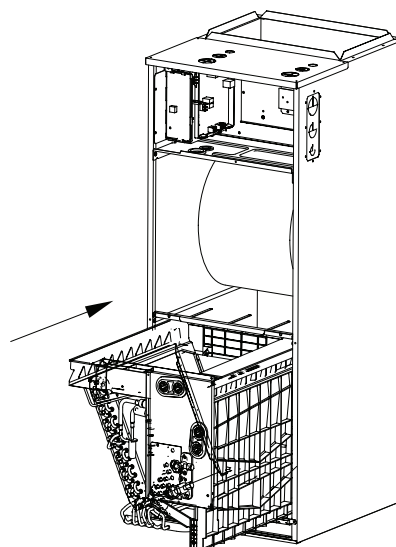

8. Reinstall T1,T2,T2A,T2B sensor plug and electronic expansion valve(EEV) and tie up the sensor wires.

Note: The wire body needs to pass through the wire groove from the drain pan and be stuck on the hook of the drain pan.

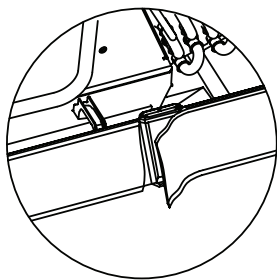
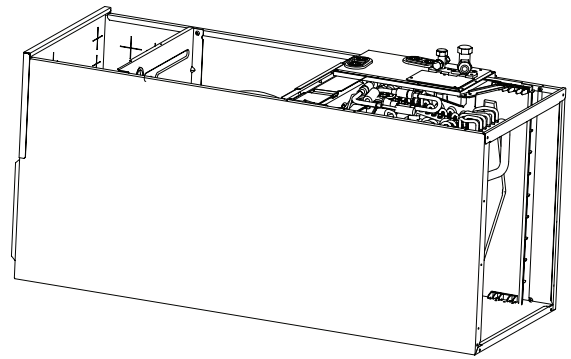
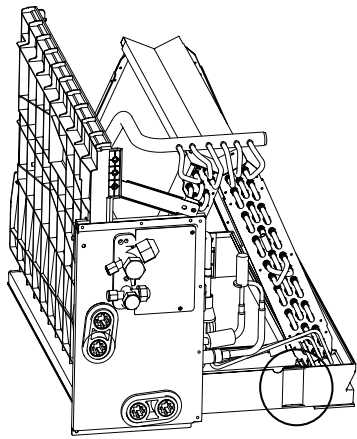

Cut the foam gasket.

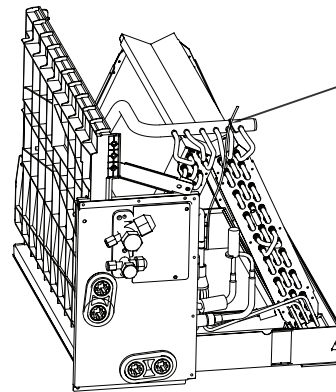

Use cable ties to fix the room temperature sensor as shown in the figure.

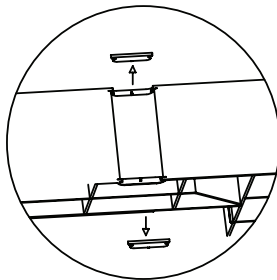

Remove knockouts as shown in the figure.

11. Reinstall evaporator cover plate.

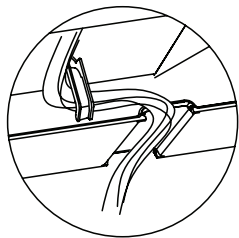

Hook the wire into the buckle and go down from the wire slot.

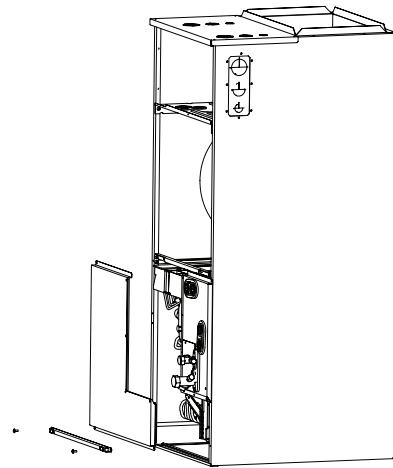

12. Connect the wire according to the wiring diagram.

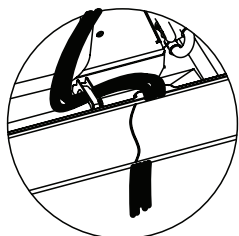

Replace foam gaster over wires.

13. Reassemble the upper cover.

10. The evaporator is assembled in place.

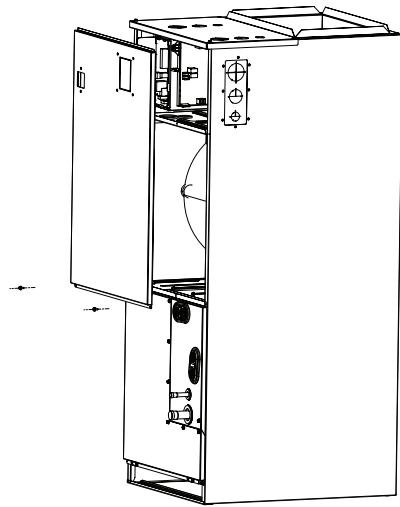

14. Reinstal the filter and filter cover plate.

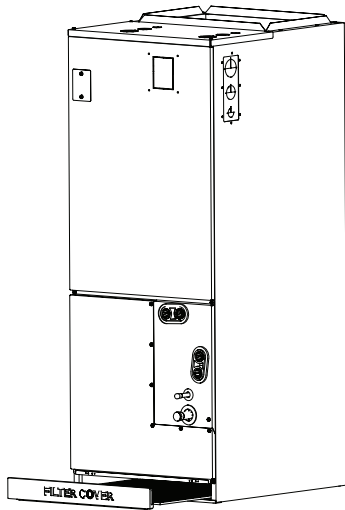





15. Connect the pipes.

16. Install the drainage pipes.

3.3 Install the Electric Auxiliary Heat Module (for some models)(not supplied)

Accessories

Name	Shape	Quantity
Manual		2
Seal sponge		1
Screw		7
Rubber cap		1
Electric auxiliary heating wiring diagram	/	1
Air switch label	/	1

NOTE:

Installation must be performed by an authorized dealer or specialist. Please make necessary protection when installing the unit.

Specification series of electric auxiliary heat module:

3kW,5kW,8kW,10kW, 15kW, 20kW,25kW.

The electric auxiliary heat module is only used for installation on the AHU internal machine.

If the unit needs to be equipped with electric auxiliary heat module, please check the electric auxiliary heat module specification that can be matched with the unit first to avoid unnecessary consequences caused by improper matching.

Selection and matching of internal machine and electric auxiliary heating components.

MODEL (Btu./h)	3kW	5kW	8kW	10kW	15kW	20kW	25kW
18K	Y	Y	Y	Y	-	-	-
24K	-	Y	Y	Y	Y	-	-
30K	-	Y	Y	Y	Y	-	-
36K	-	Y	Y	Y	Y	Y	-
48K	-	-	Y	Y	Y	Y	-
60K	-	-	-	Y	Y	Y	Y

Electric Auxiliary Heat Module installation and wiring operation

1. Remove the upper cover and use professional tools to remove the knock-out holes of the upper cover.

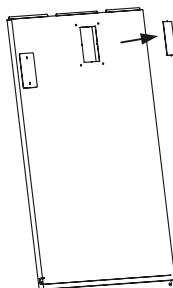
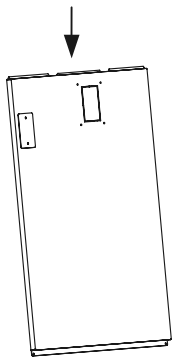
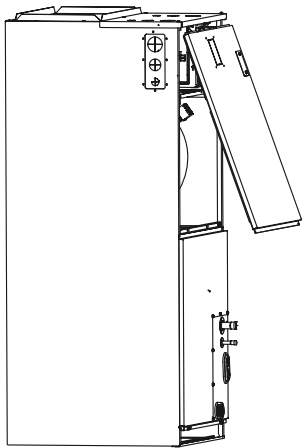

2. Remove the terminal block and power cord, loosen the screws, and remove the electric auxiliary heating cover.

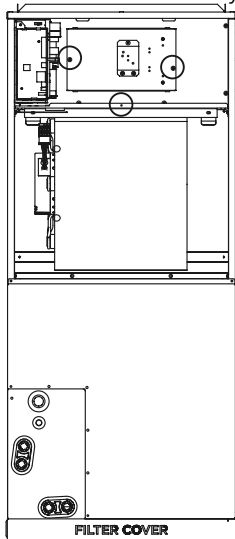

3. Install the electric auxiliary heating assembly into the chassis shell from the front, and note that the front end needs to be inserted into the shell assembly hole.

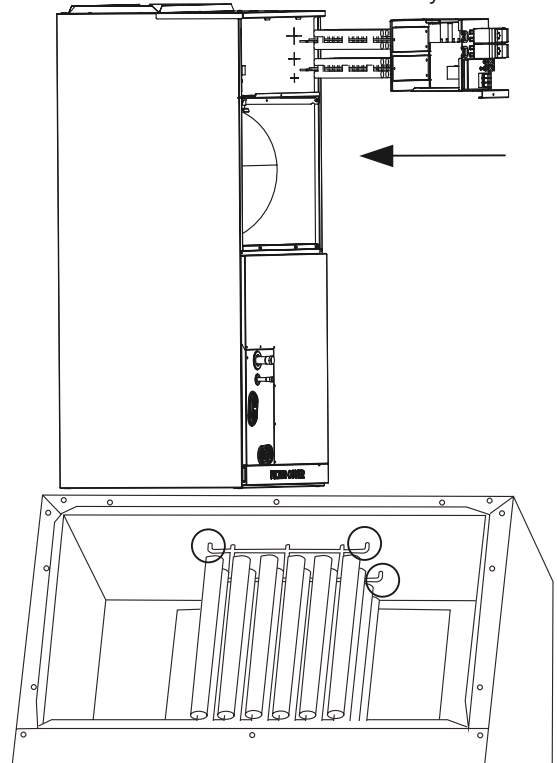

4. Tighten the mounting screws.

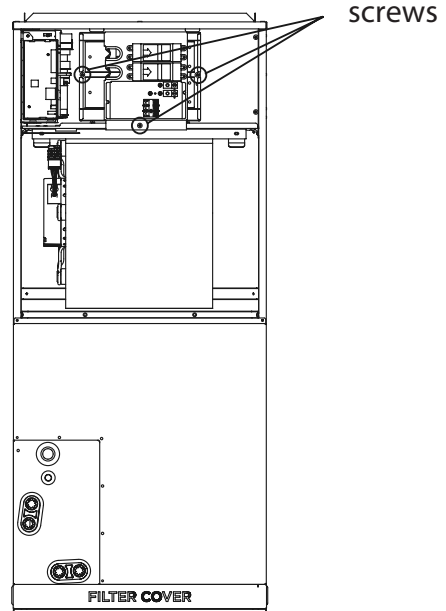

5. Wiring according to the wiring nameplate.

6. Tape the wiring diagram to the inside cover wiring is completed for future reference and maintenance.

7. Install the upper cover.

8. Install silicone breaker cover.

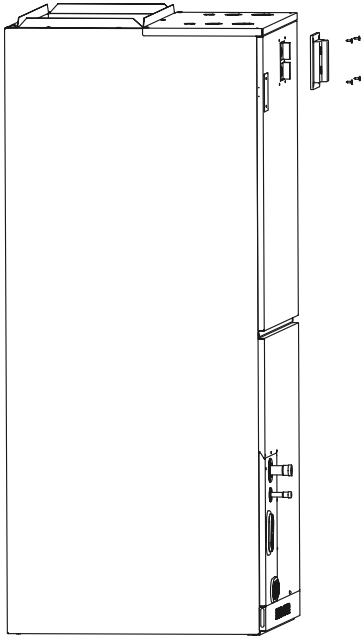

9. After installing the electric auxiliary heat module, apply the circuit breaker label near the silicone breaker cover that was just applied.

After the electric heating wiring is connected, please confirm before power on:

- Check all wiring and ensure reliable connection of wire body.
- Check the electric heating fixing screw, and the screw is fixed reliably.
- The size selection of power wire meets the power supply requirements.

Specifications	Number of circuit breakers	Number of relays	Number of power cord groups	Number of power cord grounding screws
3kW	1	1	2	2
5kW	1	1	2	2
8kW	1	2	2	2
10kW	1	2	2	2
15kW	2	3	3	3
20kW	2	4	3	3
25kW	3	5	4	4

NOTE:

- Electric auxiliary heating wiring diagram packed with the accessories.
- If branch circuit wire length exceeds 100 ft, consult NEC 210-19a to determine maximum wire length. Use 2% voltage drop.

Auxiliary Heater Electrical Data

Heater part No.	Heater kW	Internal Circuit Protection	CIRCUIT 1			CIRCUIT 2			CIRCUIT 3		
			Heater Amps	MCA (1)	MOCP (2)	Heater Amps	MCA (1)	MOCP (2)	Heater Amps	MCA (1)	MOCP (2)
EAH-03B(UL)	3	Ckt Bkr	10.8/12.0	14.0/16.0	15.0/20.0	/	/	/	/	/	/
EAH-05B(UL)	5	Ckt Bkr	18.0/20.0	23.0/27.0	25.0/30.0	/	/	/	/	/	/
EAH-08B(UL)	8	Ckt Bkr	28.8/32.0	37.0/42.0	40.0/45.0	/	/	/	/	/	/
EAH-10B(UL)	10	Ckt Bkr	36.0/40.0	46.0/53.0	50.0/60.0	/	/	/	/	/	/
EAH-15B(UL)	15	Ckt Bkr	18.0/20.0	23.0/27.0	25.0/30.0	36.0/40.0	46.0/53.0	50.0/60.0	/	/	/
EAH-20B(UL)	20	Ckt Bkr	36.0/40.0	46.0/53.0	50.0/60.0	36.0/40.0	46.0/53.0	50.0/60.0	/	/	/
EAH-25B(UL)	25	Ckt Bkr	18.0/20.0	23.0/27.0	25.0/30.0	36.0/40.0	46.0/53.0	50.0/60.0	36.0/40.0	46.0/53.0	50.0/60.0

4. Outdoor unit installation

4.1 Service space for outdoor unit

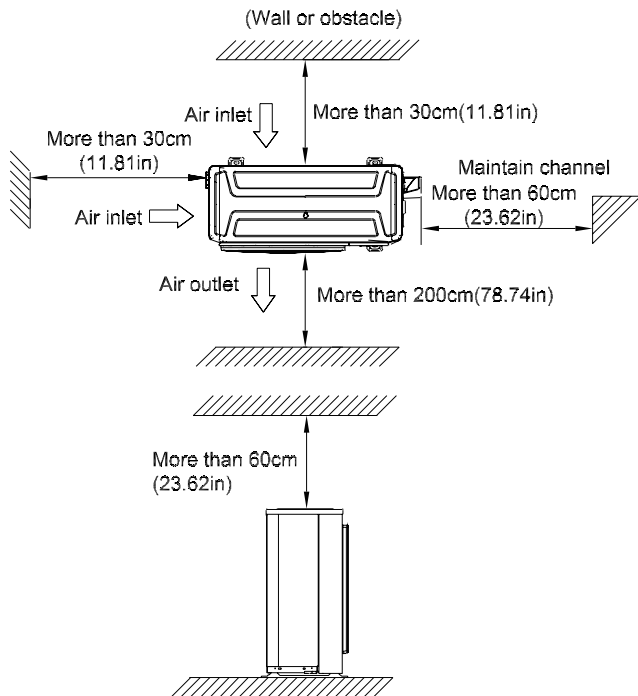

4.2 Install drain joint(Heat pump unit only)

Before bolting the outdoor unit in place, you must install the drain joint at the bottom of the unit.

Note that there are two different types of drain joints depending on the type of outdoor unit.

If the drain joint comes with a rubber seal(see Fig. A), do the following:

1. Fit the rubber seal on the end of the drain joint that will connect to the outdoor unit.
2. Insert the drain joint into the hole in the base pan of the unit.
3. Rotate the drain joint 90° until it clicks in place facing the front of the unit. **For some panel plates, you need to use tool.**
4. Connect a drain hose extension (not included) to the drain joint to redirect water from the unit during heating mode.

If the drain joint doesn't come with a rubber seal (see Fig. B), do the following:

1. Insert the drain joint into the hole in the base pan of the unit. The drain joint will click in place.

2. Connect a drain hose extension (not included) to the drain joint to redirect water from the unit during heating mode.

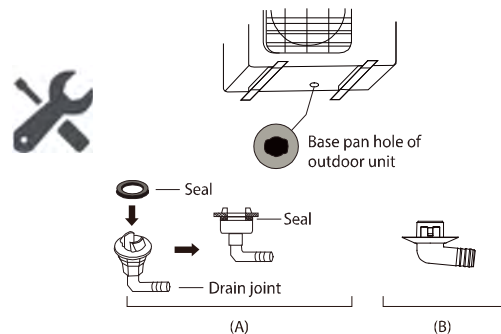

4.3 Bolt pitch

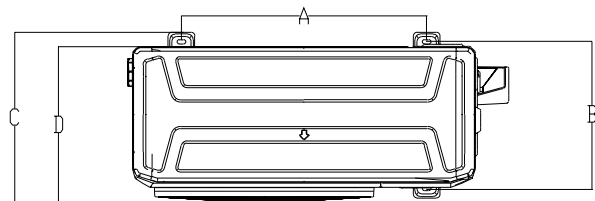

Panel Plate	Unit	D	A	B	C
X2	mm	303	452	286	314
	inch	11.93	17.80	11.26	12.36
X3	mm	330	511	317	346
	inch	12.99	20.12	12.48	13.62
X4	mm	342	663	354	394
	inch	13.46	26.1	13.94	15.5
X6	mm	375	615	397	440
	inch	14.76	24.2	15.6	17.3
D30	mm	410	673	403	455
	inch	16.14	26.50	15.87	17.9
E30	mm	415	634	404	457
	inch	16.34	24.96	15.9	17.99
590	mm	350	590	378	400
	inch	13.78	23.23	14.88	15.75

4.4 Install Outdoor Unit

Fix the outdoor unit with anchor bolts(M10)

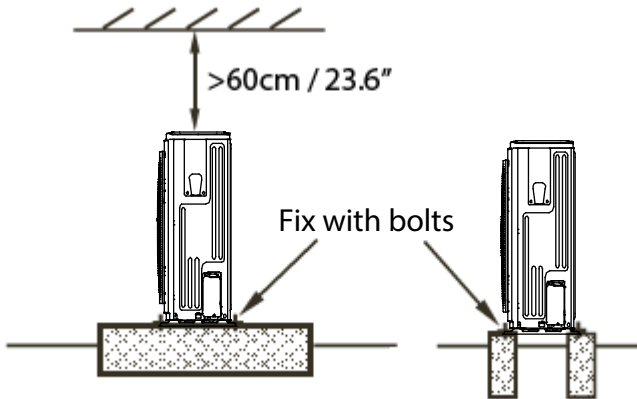

Caution

Since the gravity center of the unit is not at its physical center, so please be careful when lifting it with a sling.

Never hold the inlet of the outdoor unit to prevent it from deforming.

Do not touch the fan with hands or other objects.

Do not lean it more than 45, and do not lay it sidelong.

Make concrete foundation according to the specifications of the outdoor units.

Fasten the feet of this unit with bolts firmly to prevent it from collapsing in case of earthquake or strong wind.

5. Drainage Pipe Installation

Install the drainage pipe as shown below and take measures against condensation. Improperly installation could lead to leakage and eventually wet furniture and belongings.

5.1 Installation principle

- Ensure at least 1/100 slope of the drainage pipe
- Adopt suitable pipe diameter
- Adopt nearby condensate water discharge

5.2 Key points of drainage water pipe installation

1. Considering the pipeline route and elevation.

- Before installing condensate water pipeline, determine its route and elevation to avoid intersection with other pipelines and ensure slope is straight.

2. Drainage pipe selection

- The drainage pipe diameter shall not small than the drain hose of indoor unit
- According to the water flowrate and drainage pipe slope to choose the suitable pipe, the water flowrate is decided by the capacity of indoor unit.

Relationship between water flowrate and capacity of indoor unit

Capacity (kBtu/h)	Water flowrate (l/h)
12	2.4
18	4
24	6
30	7
36	8
42	10
48	12
60	14

According to the above table to calculate the total water flowrate for the confluence pipe selection.

For horizontal drainage pipe (The following table is for reference)

PVC pipe	Reference value of inner diameter of pipe (mm)	Allowable maximum water flowrate (l/h)		Remark
		Slope 1/50	Slope 1/100	
PVC25	20	39	27	For branch pipe
PVC32	25	70	50	
PVC40	31	125	88	Could be used for confluence pipe
PVC50	40	247	175	
PVC63	51	473	334	

Attention: Adopt PVC40 or bigger pipe to be the main pipe.

For Vertical drainage pipe (The following table is for reference)

PVC pipe	Reference value of inner diameter of pipe (mm)	Allowable maximum water flowrate (l/h)	Remark
PVC25	20	220	For branch pipe
PVC32	25	410	
PVC40	31	730	Could be used for confluence pipe
PVC50	40	1440	
PVC63	51	2760	
PVC75	67	5710	
PVC90	77	8280	

Attention: Adopt PVC40 or bigger pipe to be the main pipe.

3. Individual design of drainage pipe system

- The drainage pipe of air conditioner shall be installed separately with other sewage pipe, rainwater pipe and drainage pipe in building.
- The drainage pipe of the indoor unit with water pump should be apart from the one without water pump.

4. Supporter gap of drainage pipe

- In general, the supporter gap of the drainage pipe horizontal pipe and vertical pipe is respectively 1m~1.5m and 1.5m~2.0m.
- Each vertical pipe shall be equipped with not less than two hangers.
- Overlarge hanger gap for horizontal pipe shall create bending, thus leading to air block.

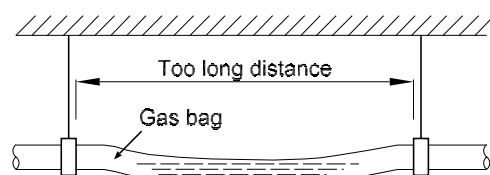

5. The horizontal pipe layout should avoid converse flow or bad flow

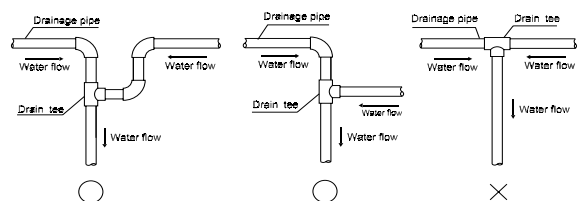

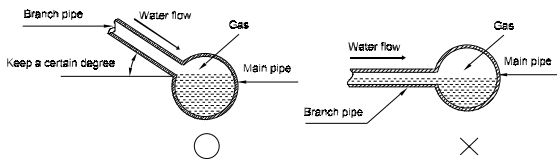

5.3 Insulation work of drainage pipe

Refer the introduction to the insulation engineering parts.

- The correct installation will not cause converse water flow and the slope of the branch pipes can be adjusted freely
- The false installation will cause converse water flow and the slope of the branch pipe can not be adjusted.

6. Water storage pipe setting

- If the indoor unit has high extra static pressure and without water pump to elevate the condensate water, such as high extra static pressure duct unit, the water storage pipe should be set to avoid converse flow or blow water phenomena.

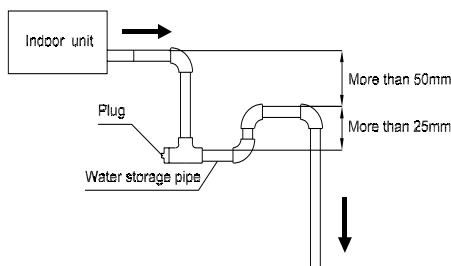

7. Blowhole setting

- For the concentrated drainage pipe system, there should design a blowhole at the highest point of main pipe to ensure the condensate water discharge smoothly.
- The air outlet shall face down to prevent dirt entering pipe.
- Each indoor unit of the system should be installed it.
- The installation should be considering the convenience for future cleaning.

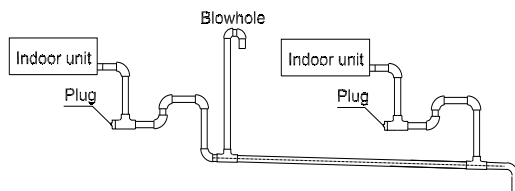

9. The end of drainage pipe shall not contact with ground directly.

6. Refrigerant Pipe Installation

6.1 Maximum length and drop height

Ensure that the length of the refrigerant pipe, the number of bends, and the drop height between the indoor and outdoor units meets the requirements shown in the following table.

Capacity(kBtu/h)	Max. Length (m/ft)	Max. Elevation (m/ft)
<15	25/82	10/32.8
15-23	30/98.4	20/65.6
24~35	50/164	25/82
36~60	65/213.3	30/98.4

Caution:

1. The capacity test is based on the standard length and the maximum permissible length is based on the system reliability.

2. Oil traps

-If oil flows back into the outdoor unit's compressor, this might cause liquid compression or deterioration of oil return. Oil traps in the rising gas piping can prevent this.

-An oil trap should be installed every 6m(20ft) of vertical suction line riser (<36000Btu/h unit).

-An oil trap should be installed every 10m(32.8ft) of vertical suction line riser (\geq 36000Btu/h unit).

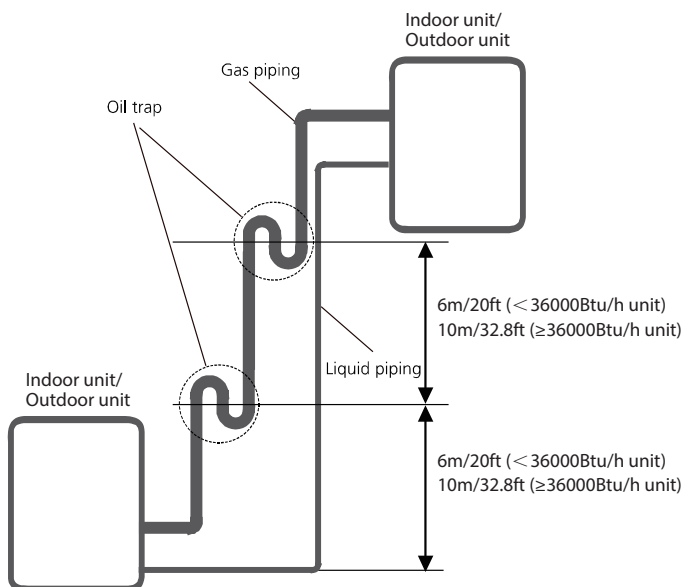

6.2 The procedure of connecting pipes

1. Choose the pipe size according to the specification table.

2. Confirm the cross way of the pipes.

3. Measure the necessary pipe length.

4. Cut the selected pipe with pipe cutter

- Make the section flat and smooth.

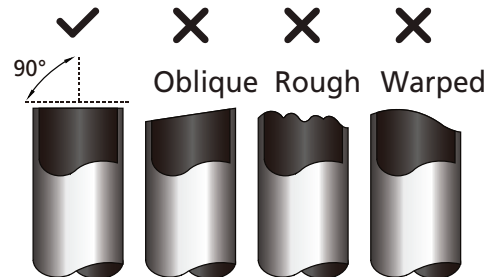

5. Insulate the copper pipe

- Before test operation, the joint parts should not be heat insulated.

6. Flare the pipe

- Insert a flare nut into the pipe before flaring the pipe
- According to the following table to flare the pipe.

Pipe diameter (inch(mm))	Flare dimension A (mm/inch)		Flare shape
	Min	Max	
1/4" (6.35)	8.4/0.33	8.7/0.34	
3/8" (9.52)	13.2/0.52	13.5/0.53	
1/2" (12.7)	16.2/0.64	16.5/0.65	
5/8" (15.9)	19.2/0.76	19.7/0.78	
3/4" (19)	23.2/0.91	23.7/0.93	
7/8" (22)	26.4/1.04	26.9/1.06	

- After flared the pipe, the opening part must be seal by end cover or adhesive tape to avoid duct or exogenous impurity come into the pipe.

7. Drill holes if the pipes need to pass the wall.

8. According to the field condition to bend the pipes so that it can pass the wall smoothly.

9. Bind and wrap the wire together with the insulated pipe if necessary.

10. Set the wall conduit
11. Set the supporter for the pipe.
12. Locate the pipe and fix it by supporter
 - For horizontal refrigerant pipe, the distance between supporters should not be exceed 1m.
 - For vertical refrigerant pipe, the distance between supporters should not be exceed 1.5m.
13. Connect the pipe to indoor unit and outdoor unit by using two spanners.
 - Be sure to use two spanners and proper torque to fasten the nut, too large torque will damage the bell mouthing, and too small torque may cause leakage. Refer the following table for different pipe connection.

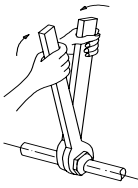
Pipe Diameter	Torque	Sketch map
	N.m(lb.ft)	
1/4" (6.35)	18~20 (13.3~14.8)	
3/8" (9.52)	32~39 (23.6~28.8)	
1/2" (12.7)	49~59 (36.1~43.5)	
5/8" (15.9)	57~71 (42~52.4)	
3/4" (19)	67~101 (49.4~74.5)	
7/8" (22)	85~110 (62.7~81.1)	

7. Vacuum Drying and Leakage Checking

7.1 Purpose of vacuum drying

- Eliminating moisture in system to prevent the phenomena of ice-blockage and copper oxidation. Ice-blockage shall cause abnormal operation of system, while copper oxide shall damage compressor.
- Eliminating the non-condensable gas (air) in system to prevent the components oxidizing, pressure fluctuation and bad heat exchange during the operation of system.

7.2 Selection of vacuum pump

- The ultimate vacuum degree of vacuum pump shall be -756mmHg or above.
- Precision of vacuum pump shall reach 0.02mmHg or above.

7.3 Operation procedure for vacuum drying

Due to different construction environment, two kinds of vacuum drying ways could be chosen, namely ordinary vacuum drying and special vacuum drying.

7.3.1 Ordinary vacuum drying

1. When conduct first vacuum drying, connect pressure gauge to the infusing mouth of gas pipe and liquid pipe, and keep vacuum pump running for 1 hour (vacuum degree of vacuum pump shall be reached -755mmHg).
2. If the vacuum degree of vacuum pump could not reach -755mmHg after 1 hour of drying, it indicates that there is moisture or leakage in pipeline system and need to go on with drying for half an hour.
3. If the vacuum degree of vacuum pump still could not reach -755mmHg after 1.5 hours of drying, check whether there is leakage source.
4. Leakage test: After the vacuum degree reaches -755mmHg, stop vacuum drying and keep the pressure for 1 hour. If the indicator of vacuum gauge does not go up, it is qualified. If going up, it indicates that there is moisture or leak source.

7.3.2 Special vacuum drying

The special vacuum drying method shall be adopted when:

1. Finding moisture during flushing refrigerant pipe.
2. Conducting construction on rainy day, because rain water might penetrated into pipeline.
3. Construction period is long, and rain water might penetrated into pipeline.

4. Rain water might penetrate into pipeline during construction.

Procedures of special vacuum drying are as follows:

1. Vacuum drying for 1 hour.
2. Vacuum damage, filling nitrogen to reach 0.5Kgf/cm² .

Because nitrogen is dry gas, vacuum damage could achieve the effect of vacuum drying, but this method could not achieve drying thoroughly when there is too much moisture. Therefore, special attention shall be drawn to prevent the entering of water and the formation of condensate water.

3. Vacuum drying again for half an hour.

If the pressure reached -755mmHg, start to pressure leakage test. If it cannot reached the value, repeat vacuum damage and vacuum drying again for 1 hour.

4. Leakage test: After the vacuum degree reaches -755mmHg, stop vacuum drying and keep the pressure for 1 hour. If the indicator of vacuum gauge does not go up, it is qualified. If going up, it indicates that there is moisture or leak source.

8. Additional Refrigerant Charge

- After the vacuum drying process is carried out, the additional refrigerant charge process need to be performed.
- The outdoor unit is factory charged with refrigerant. The additional refrigerant charge volume is decided by the diameter and length of the liquid pipe between indoor and outdoor unit. Refer the following formula to calculate the charge volume.

	Diameter of liquid pipe (mm(inch))	Formula
R410A(Throttling part in the indoor unit)	6.35(1/4)	$V=30(0.32)g/m(oz/ft) \times (L - \text{standard pipe length})$
	9.52(3/8)	$V=65(0.69)g/m(oz/ft) \times (L - \text{standard pipe length})$
	12.7(1/2)	$V=115(1.23)g/m(oz/ft) \times (L - \text{standard pipe length})$
R410A(Throttling part in the outdoor unit)	6.35(1/4)	$V=15(0.16)g/m(oz/ft) \times (L - \text{standard pipe length})$
	9.52(3/8)	$V=30(0.32)g/m(oz/ft) \times (L - \text{standard pipe length})$
	12.7(1/2)	$V=65(0.69)g/m(oz/ft) \times (L - \text{standard pipe length})$
R32	6.35(1/4)	$V=12(0.13)g/m(oz/ft) \times (L - \text{standard pipe length})$
	9.52(3/8)	$V=24(0.26)g/m(oz/ft) \times (L - \text{standard pipe length})$
	12.7(1/2)	$V=40(0.42)g/m(oz/ft) \times (L - \text{standard pipe length})$

V: Additional refrigerant charge volume.

L : The length of the liquid pipe.

Note:

- Refrigerant may only be charged after performed the vacuum drying process.
- Always use gloves and glasses to protect your hands and eyes during the charge work.
- Use electronic scale or fluid infusion apparatus to weight refrigerant to be recharged. Be sure to avoid extra refrigerant charged, it may cause liquid hammer of the compressor or protections.
- Use supplementing flexible pipe to connect refrigerant cylinder, pressure gauge and outdoor unit. And The refrigerant should be charged in liquid state. Before recharging, The air in the flexible pipe and manifold gauge should be exhausted.
- After finished refrigerant recharge process, check whether there is refrigerant leakage at the connection joint part.(Using gas leakage detector or soap water to detect).

9 . Engineering of Insulation

9.1 Insulation of refrigerant pipe

1. Operational procedure of refrigerant pipe insulation

Cut the suitable pipe → insulation (except joint section) → flare the pipe → piping layout and connection → vacuum drying → insulate the joint parts

2. Purpose of refrigerant pipe insulation

- During operation, temperature of gas pipe and liquid pipe shall be over-heating or over-cooling extremely. Therefore, it is necessary to carry out insulation; otherwise it shall debase the performance of unit and burn compressor.
- Gas pipe temperature is very low during cooling. If insulation is not enough, it shall form dew and cause leakage.
- Temperature of gas pipe is very high (generally 50-100 °C) during heating. Insulation work must be carried out to prevent hurt by carelessness touching.

3. Insulation material selection for refrigerant pipe

- The burning performance should over 120 °C
- According to the local law to choose insulation materials
- The thickness of insulation layer shall be above 10mm. If in hot or wet environment place, the layer of insulation should be thicker accordingly.

4. Installation highlights of insulation construction

- Gas pipe and liquid pipe shall be insulated separately, if the gas pipe and liquid pipe were insulated together; it will decrease the performance of air conditioner.

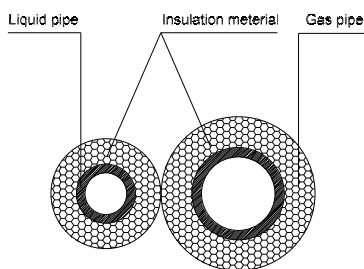

- The insulation material at the joint pipe shall be 5~10cm longer than the gap of the insulation material.
- The insulation material at the joint pipe shall be inserted into the gap of the insulation material.
- The insulation material at the joint pipe shall be banded to the gap pipe and liquid pipe tightly.
- The linking part should be use glue to paste together
- Be sure not bind the insulation material over-tight, it may extrude out the air in the material to cause bad

insulation and cause easy aging of the material.

9.2 Insulation of drainage pipe

1. Operational procedure of refrigerant pipe insulation

Select the suitable pipe → insulation (except joint section) → piping layout and connection → drainage test → insulate the joint parts

2. Purpose of drainage pipe insulation

The temperature of condensate drainage water is very low. If insulation is not enough, it shall form dew and cause leakage to damage the house decoration.

3. Insulation material selection for drainage pipe

- The insulation material should be flame retardant material, the flame retardancy of the material should be selected according to the local law.
- Thickness of insulation layer is usually above 10mm.
- Use specific glue to paste the seam of insulation material, and then bind with adhesive tape. The width of tape shall not be less than 5cm. Make sure it is firm and avoid dew.

4. Installation and highlights of insulation construction

- The single pipe should be insulated before connecting to another pipe, the joint part should be insulated after the drainage test.
- There should be no insulation gap between the insulation material.

10. Engineering of Electrical Wring

1. Highlights of electrical wiring installation

- All field wiring construction should be finished by qualified electrician.
- Air conditioning equipment should be grounded according to the local electrical regulations.
- Current leakage protection switch should be installed.
- Do not connect the power wire to the terminal of signal wire.
- When power wire is parallel with signal wire, put wires to their own wire tube and remain at least 300mm gap.
- According to table in indoor part named "the specification of the power" to choose the wiring, make sure the selected wiring not small than the date showing in the table.
- Select different colors for different wire according to relevant regulations.
- Do not use metal wire tube at the place with acid or alkali corrosion, adopt plastic wire tube to replace it.
- There must be not wire connect joint in the wire tube If joint is a must, set a connection box at the place.
- The wiring with different voltage should not be in one wire tube.
- Ensure that the color of the wires of outdoor and the terminal No. are same as those of indoor unit respectively.

Table: Minimum Cross-Sectional Area able of Power and Signal Cables

For North America:

Rated Current of Appliance (A)	AWG
≤ 6	18
6 - 10	16
10 - 16	14
16 - 25	12
25 - 32	10

For the other regions:

Rated Current of Appliance (A)	Nominal Cross-Sectional Area(mm ²)
≤ 6	0.75
6 - 10	1
10 - 16	1.5
16 - 25	2.5
25 - 32	4
32 - 45	6

2. Specific wiring method

Connection method A:

Refer to the wiring method of internal and external machine communication and wired controller as follows:

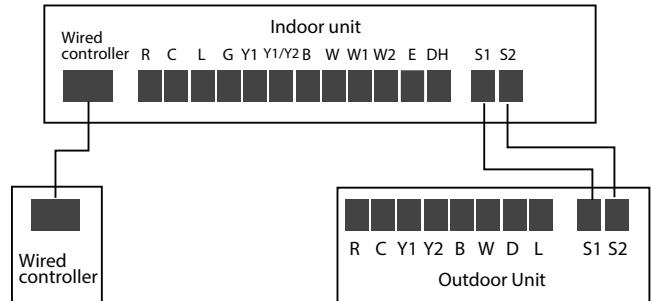

Connection method B:

To use a 24V thermostat, you need to refer to the following wiring:

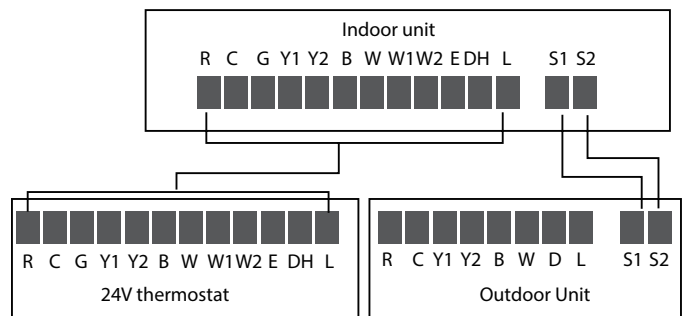

NOTE: The wiring method of the thermostat and the internal machine refers to the wiring of the non-communication scheme.

Connection method C:

Non-communication scheme wiring reference

- Wiring for 4H and 2C thermostat

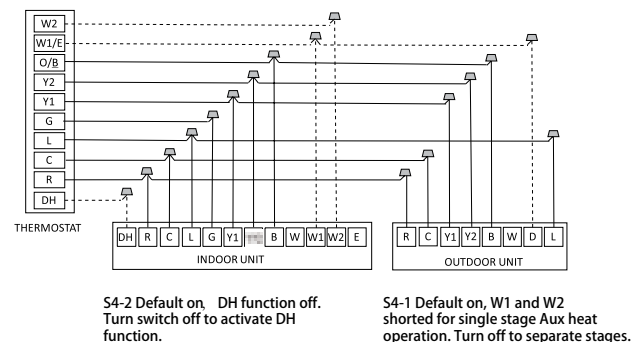

• Wiring for 3H and 1C thermostat

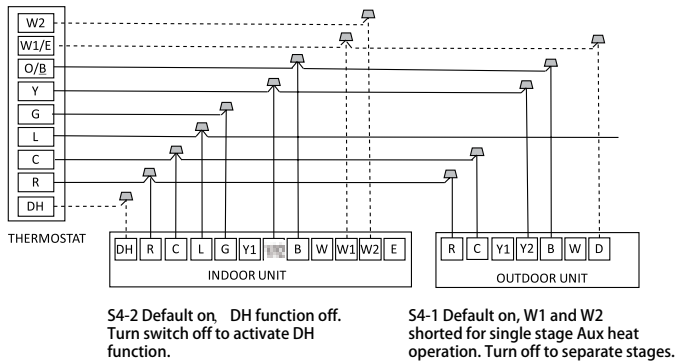

• Wiring for 2H and 1C thermostat

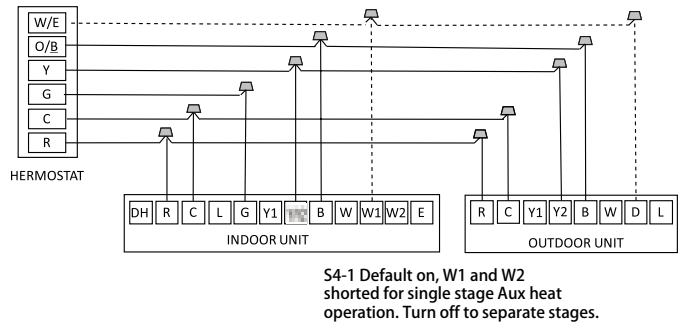

• Wiring for 3H and 2C thermostat

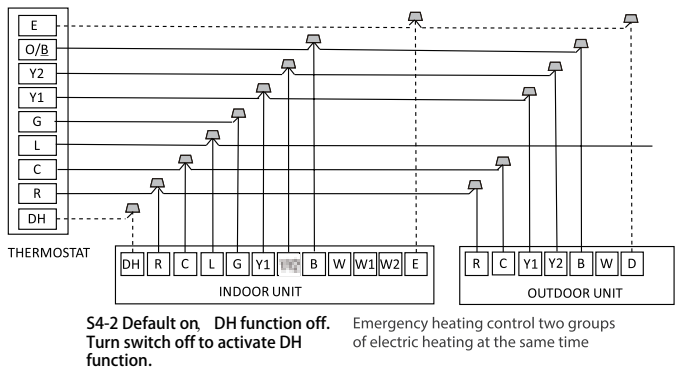

• Wiring for 1H and 1C thermostat

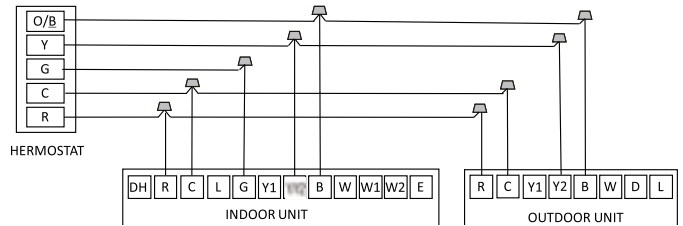

• Wiring for 1H and 1C thermostat

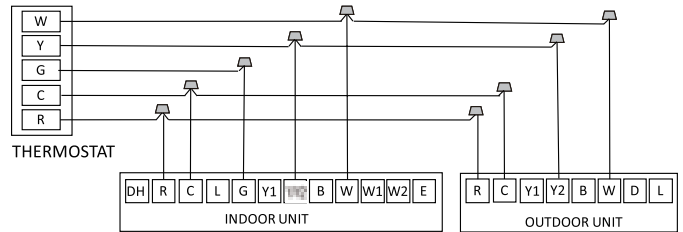

• Wiring for 3H and 2C thermostat

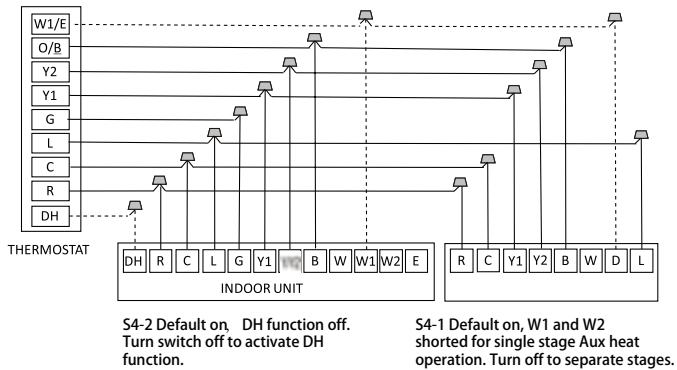

• Wiring for 2H and 2C thermostat

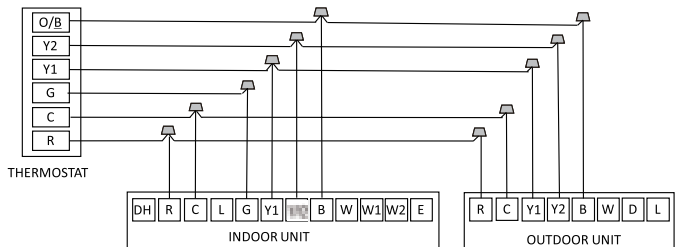

Note:

When the indoor and outdoor unit is connected without communication (connection mode C), indoor sensor fault and fan fault, the indoor unit plate outputs L signal to the temperature controller, and the temperature controller shall send out stop command to the outdoor unit .

If the temperature controller provided by the customer is not equipped with the output stop instruction of the outdoor unit , the outdoor units are not allowed to run in the non-communication mode. Please use connection mode B.

3. Optional function wiring

3.1 Condensate overflow switch

The unit will accommodate a remote condensate overflow switch. To enable, remote jumper J1, and connect the installer provided condensate overflow device to CN5 per below. When an overflow condition is present, the device should open connection signaling the unit to turn off the system.

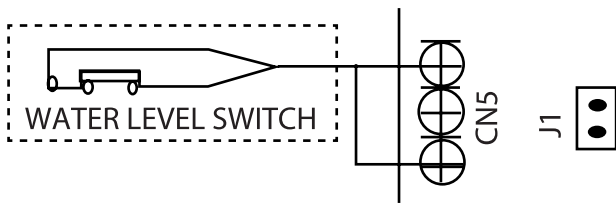

3.2 The fault warning

Alarm output:

An alarm output(CN33) can be utilized if actions are required when a fault is present. This is a passive outlet port, so you will need to input a voltage signal. The relay is normally-open for normal operation, and closed when a fault condition is active.

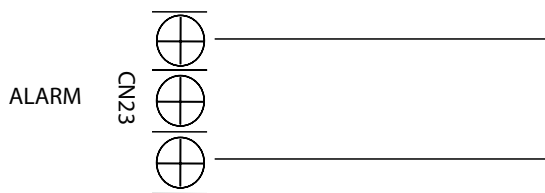

3.3 Humidification control wiring

- To connect a humidifier, utilize the passive signal "WORK" output (CN23) port as well as the G and C wires on the controller, and wire the humidistat and humidifier per above wiring diagram. When the fan is running, the CN23 relay will be closed, which will allow power to the humidifier when the humidistat is below humidity setpoint. If the thermostat or zone controller has an HUM interface, connect the humidifier directly to the HUM and C ports.

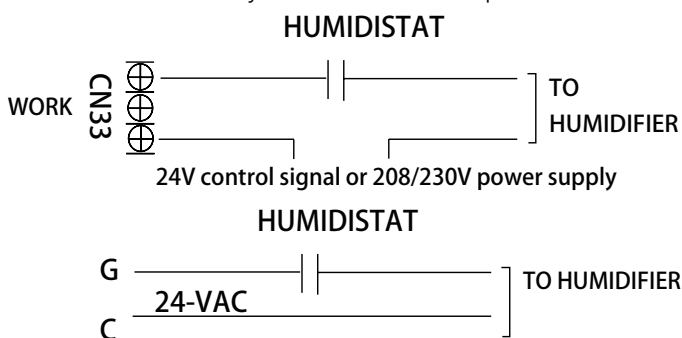

3.4 Dehumidification control wiring

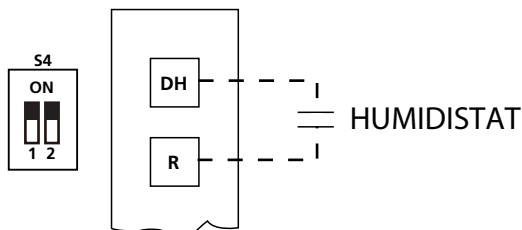

Dehumidification control requires indirect humidifier at DH and R. Set S4-2 as OFF. When the humidity rises and exceeds the set value of the humidifier, the 24V

signal of DH changes to 0V, the cooling system starts the dehumidification operation, and the air volume drops to 80% of the nominal cooling air volume.

3.5 UV, fresh air or negative ion wiring

The WORK port is linked with the fan. When the fan is running, the relay is closed; if an active 24V signal is required, it can be directly connected to the G and C ports.

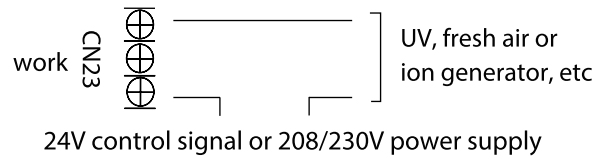

4. Control Logic

Indoor unit Connector

Connector	Purpose
R	24V Power Connection
C	Common
G	Fan Control
Y1	Low Cooling
Y/Y2	High Cooling
B	Heating Reversing Valve
W	Heating Control
W1	Stage 1 Electric heating
W2	Stage 2 Electric heating
E/AUX	Emergency heating
DH/DS/BK	Dehumidification/Zoning control
L	System Fault Signal

Outdoor unit Connector

Connector	Purpose
R	24V Power Connection
C	Common
Y1	Low Cooling
Y2	High Cooling
B	Heating Reversing Valve
W	Heating Control
D	Defrost Control
L	System Fault Signal

11. Test Operation

1. The test operation must be carried out after the entire installation has been completed.

2. Please confirm the following points before the test operation.

- The indoor unit and outdoor unit are installed properly.
- Piping and wiring are properly connected.
- Ensure that there are no obstacles near the inlet and outlet of the unit that might cause poor performance or product malfunction.
- The refrigeration system does not leak.
- The drainage system is unimpeded and draining to a safe location.
- The heating insulation is properly installed.
- The grounding wires are properly connected
- The length of the piping and the added refrigerant stow capacity have been recorded.
- The power voltage is the correct voltage for the air conditioner.

CAUTION: Failure to perform the test run may result in unit damage, property damage or personal injury.

3. Test Run Instructions

1. Open both the liquid and gas stop valves.
2. Turn on the main power switch and allow the unit to warm up.
3. Set the air conditioner to COOL mode, and check the following points.

Indoor unit

- Double check to see if the room temperature is being registered correctly.
- Ensure the manual buttons on the indoor unit works properly.
- Check to see that the drainage system is unimpeded and draining smoothly.
- Ensure there is no vibration or abnormal noise during operation.

Outdoor unit

- Check to see if the refrigeration system is leaking.
- Make sure there is no vibration or abnormal noise during operation.
- Ensure the wind, noise, and water generated by the unit do not disturb your neighbors or pose a safety hazard.

4. Drainage Test

a. Ensure the drainpipe flows smoothly. New buildings should perform this test before finishing the ceiling.

b. Turn on the main power switch and run the air conditioner in COOL mode.

c. Check to see that the water is discharged. It may take up to one minute before the unit begins to drain depending on the drainpipe.

d. Make sure that there are no leaks in any of the piping.

e. Stop the air conditioner. Turn off the main power switch and reinstall the test cover.

Maintenance

Contents

1.	First Time Installation Check	2
2	Refrigerant Recharge	4
3	Re-Installation	5
3.1	Indoor Unit.....	5
3.2	Outdoor Unit.....	7

1. First Time Installation Check

Air and moisture trapped in the refrigerant system affects the performance of the air conditioner by:

- Increasing pressure in the system.
- Increasing the operating current.
- Decreasing the cooling or heating efficiency.
- Congesting the capillary tubing due to ice build-up in the refrigerant circuit.
- Corroding the refrigerant system.

To prevent air and moisture from affecting the air conditioner's performance, the indoor unit, as well as the pipes between the indoor and outdoor unit, must be leak tested and evacuated.

Leak test (soap water method)

Use a soft brush to apply soapy water or a neutral liquid detergent onto the indoor unit connections and outdoor unit connections. If there is gas leakage, bubbles will form on the connection.

Air purging with vacuum pump

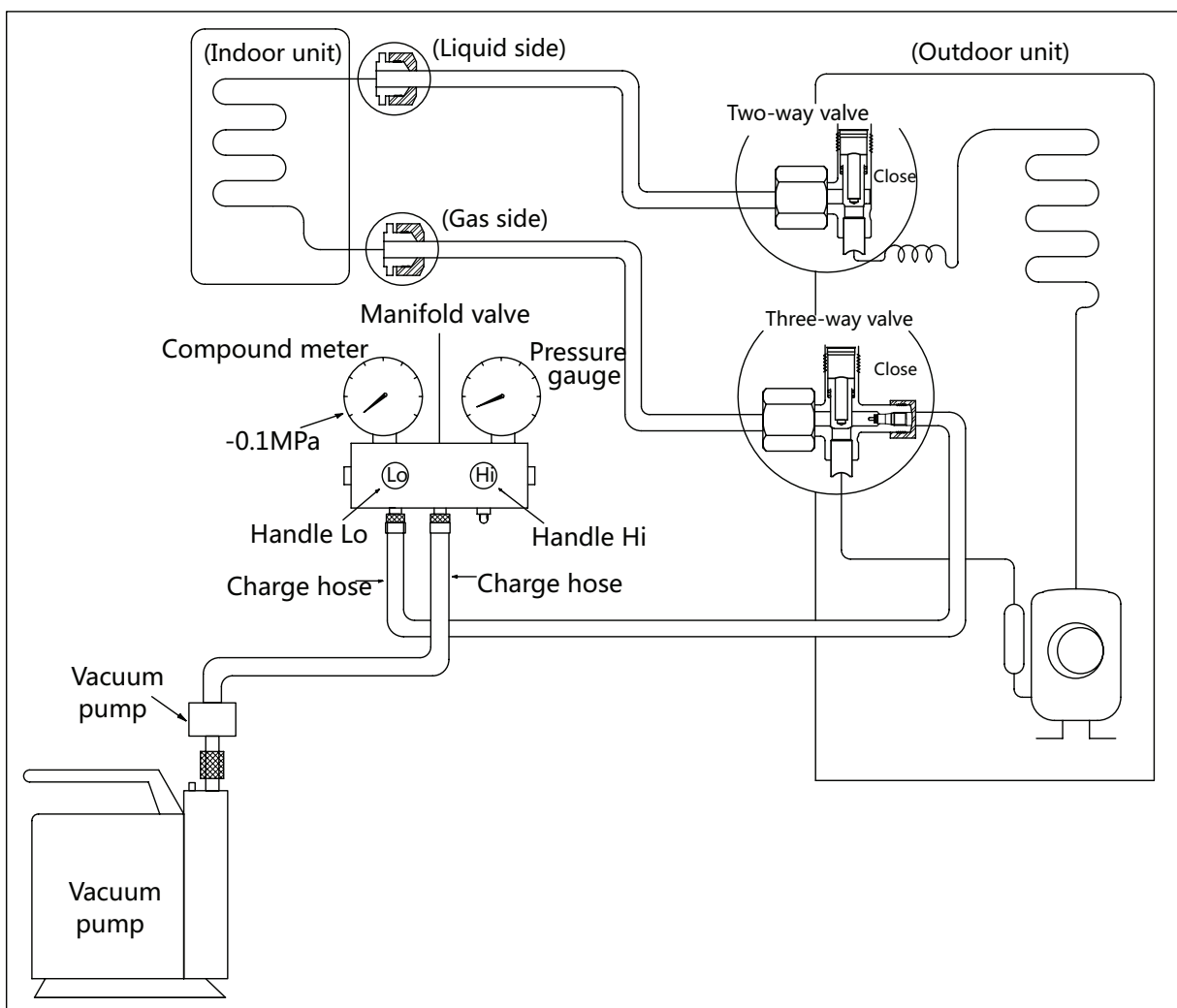

Procedure:

1. Tighten the flare nuts of the indoor and outdoor units, and confirm that both the 2- and 3-way valves are closed.
2. Connect the charge hose with the push pin of Handle Lo to the gas service port of the 3-way valve.
3. Connect another charge hose to the vacuum pump.
4. Fully open the Handle Lo manifold valve.
5. Using the vacuum pump, evacuate the system for 30 minutes.
 - a. Check whether the compound meter indicates -0.1 MPa (14.5 Psi).
 - If the meter does not indicate -0.1 MPa (14.5 Psi) after 30 minutes, continue evacuating for an additional 20 minutes.
 - If the pressure does not achieve -0.1 MPa (14.5 Psi) after 50 minutes, check for leakage.
- If the pressure successfully reaches -0.1 MPa (14.5 Psi), fully close the Handle Lo valve, then cease vacuum pump operations.
- b. Wait for 5 minutes then check whether the gauge needle moves after turning off the vacuum pump. If the gauge needle moves backward, check whether there is gas leakage.
6. Loosen the flare nut of the 3-way valve for 6 or 7 seconds and then tighten the flare nut again.
 - a. Confirm the pressure display in the pressure indicator is slightly higher than the atmospheric pressure.
 - b. Remove the charge hose from the 3-way valve.
7. Fully open the 2- and 3-way valves and tighten the cap of the 2- and 3-way valves.

2. Refrigerant Recharge

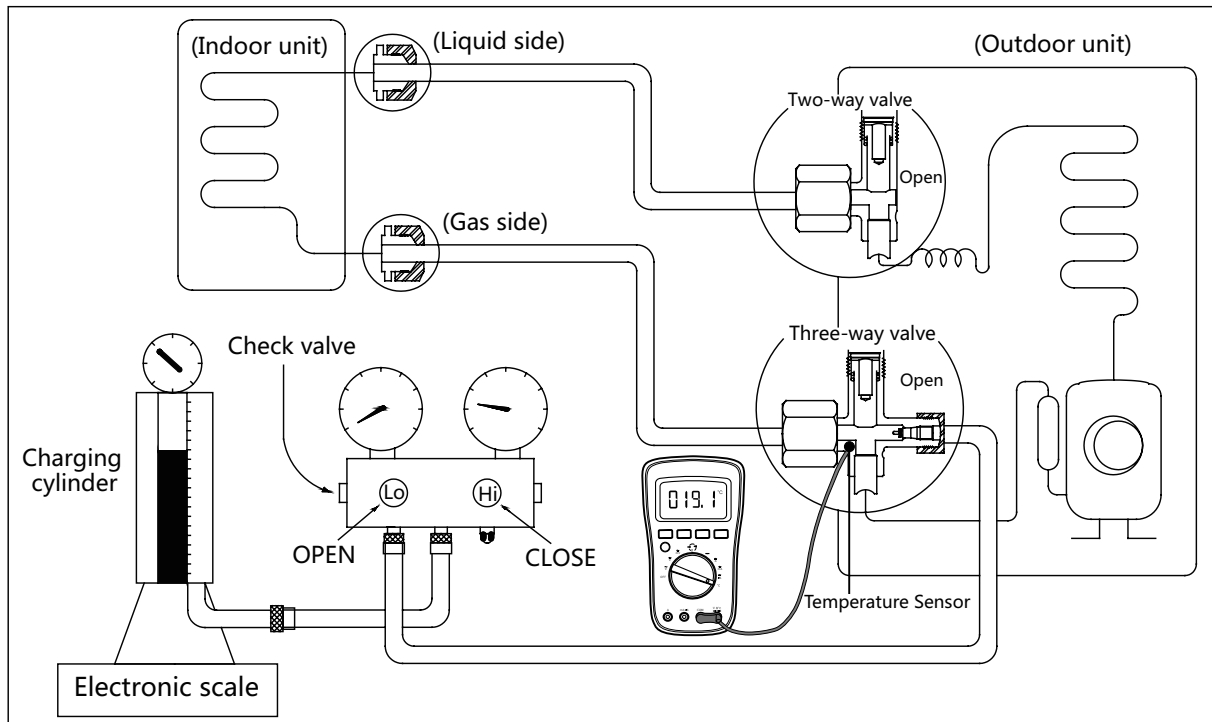

Procedure:

1. Close both 2- and 3-way valves.
2. Slightly connect the Handle Lo charge hose to the 3-way service port.
3. Connect the charge hose to the valve at the bottom of the cylinder.
4. If the refrigerant is R410A/R32, invert the cylinder to ensure a complete liquid charge.
5. Open the valve at the bottom of the cylinder for 5 seconds to purge the air in the charge hose, then fully tighten the charge hose with push pin Handle Lo to the service port of 3-way valve..
6. Place the charging cylinder onto an electronic scale and record the starting weight.
7. Fully open the Handle Lo manifold valve, 2- and 3-way valves.
8. Operate the air conditioner in cooling mode to charge the system with liquid refrigerant.
9. When the electronic scale displays the correct weight (refer to the gauge and the pressure of the low side to confirm, the value of pressure refers to chapter Appendix), turn off the air conditioner, then disconnect the charge hose from the 3-way service port immediately..
10. Mount the caps of service port and 2- and 3-way valves.
11. Use a torque wrench to tighten the caps to a torque of 18 N.m.
12. Check for gas leakage.

3. Re-Installation

3.1 Indoor Unit

Collecting the refrigerant into the outdoor unit

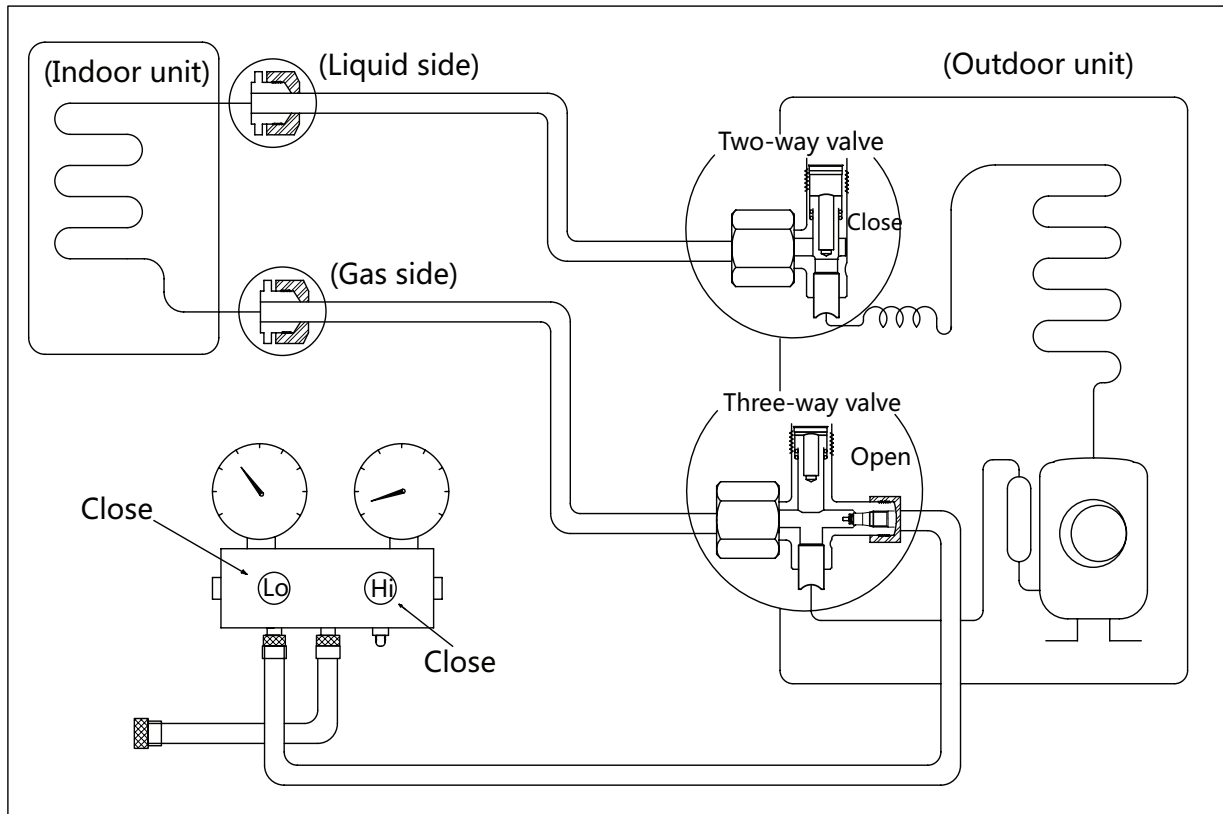

Procedure:

1. Confirm that the 2- and 3-way valves are opened.
2. Connect the charge hose with the push pin of Handle Lo to the 3-way valve's gas service port.
3. Open the Handle Lo manifold valve to purge air from the charge hose for 5 seconds and then close it quickly.
4. Close the 2-way valve.
5. Operate the air conditioner in cooling mode. Cease operations when the gauge reaches 0.1 MPa (14.5 Psi).
6. Close the 3-way valve so that the gauge rests between 0.3 MPa (43.5 Psi) and 0.5 MPa (72.5 Psi).
7. Disconnect the charge set and mount the caps of service port and 2- and 3-way valves.
8. Use a torque wrench to tighten the caps to a torque of 18 N.m.
9. Check for gas leakage.

Air purging with vacuum pump

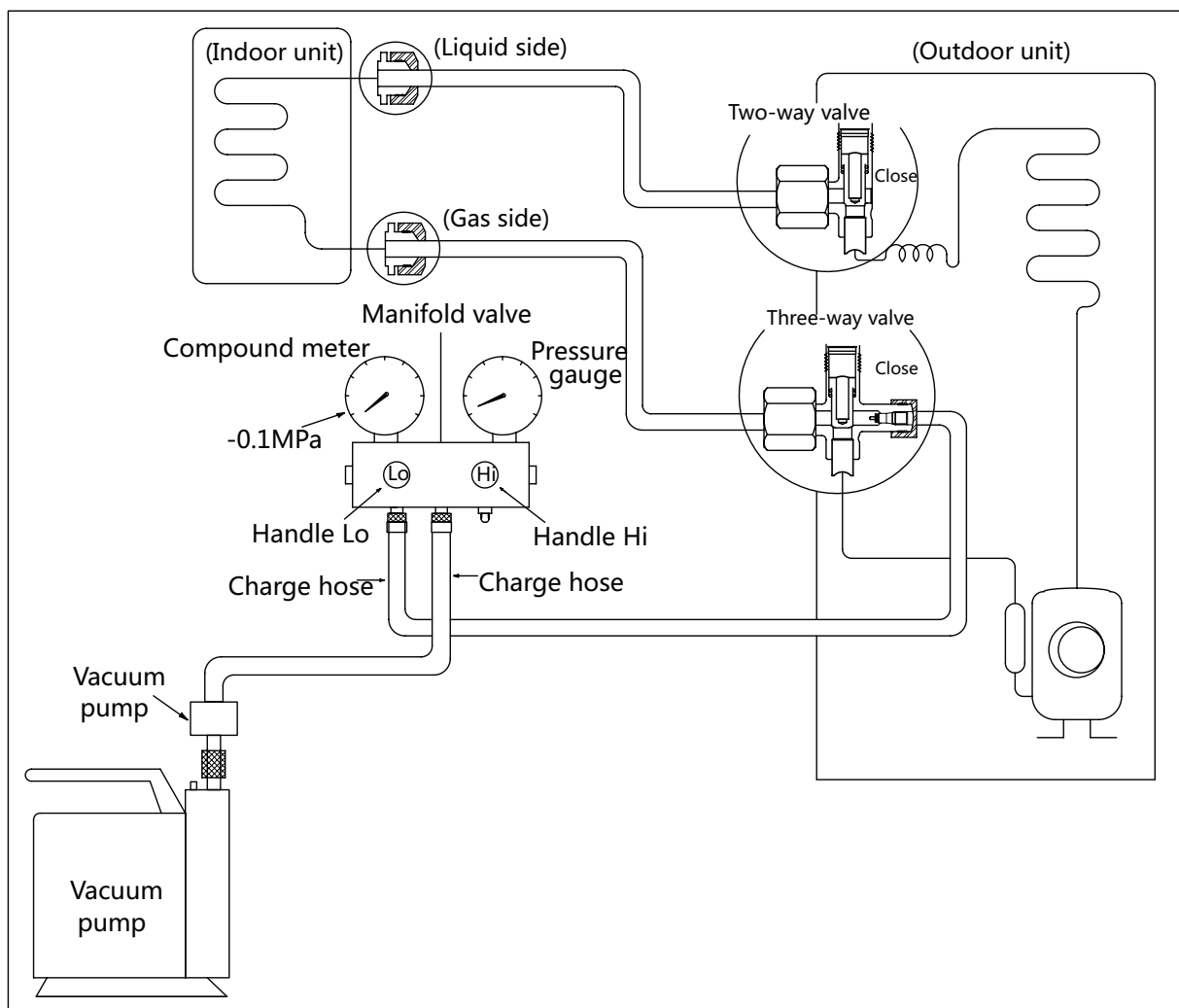

Procedure:

1. Tighten the flare nuts of the indoor and outdoor units, and confirm that both the 2- and 3-way valves are closed.
2. Connect the charge hose with the push pin of Handle Lo to the gas service port of the 3-way valve.
3. Connect another charge hose to the vacuum pump.
4. Fully open the Handle Lo manifold valve.
5. Using the vacuum pump, evacuate the system for 30 minutes.
 - a. Check whether the compound meter indicates -0.1 MPa (14.5 Psi).
 - If the meter does not indicate -0.1 MPa (14.5 Psi) after 30 minutes, continue evacuating for an additional 20 minutes.
 - If the pressure does not achieve -0.1 MPa (14.5 Psi) after 50 minutes, check for leakage.
 - b. If the pressure successfully reaches -0.1 MPa (14.5 Psi), fully close the Handle Lo valve, then cease vacuum pump operations.
6. Loosen the flare nut of the 3-way valve for 6 or 7 seconds and then tighten the flare nut again.
 - a. Confirm the pressure display in the pressure indicator is slightly higher than the atmospheric pressure.
 - b. Remove the charge hose from the 3-way valve.
7. Fully open the 2- and 3-way valves and tighten the cap of the 2- and 3-way valves.

3.2 Outdoor Unit

Evacuation for the whole system

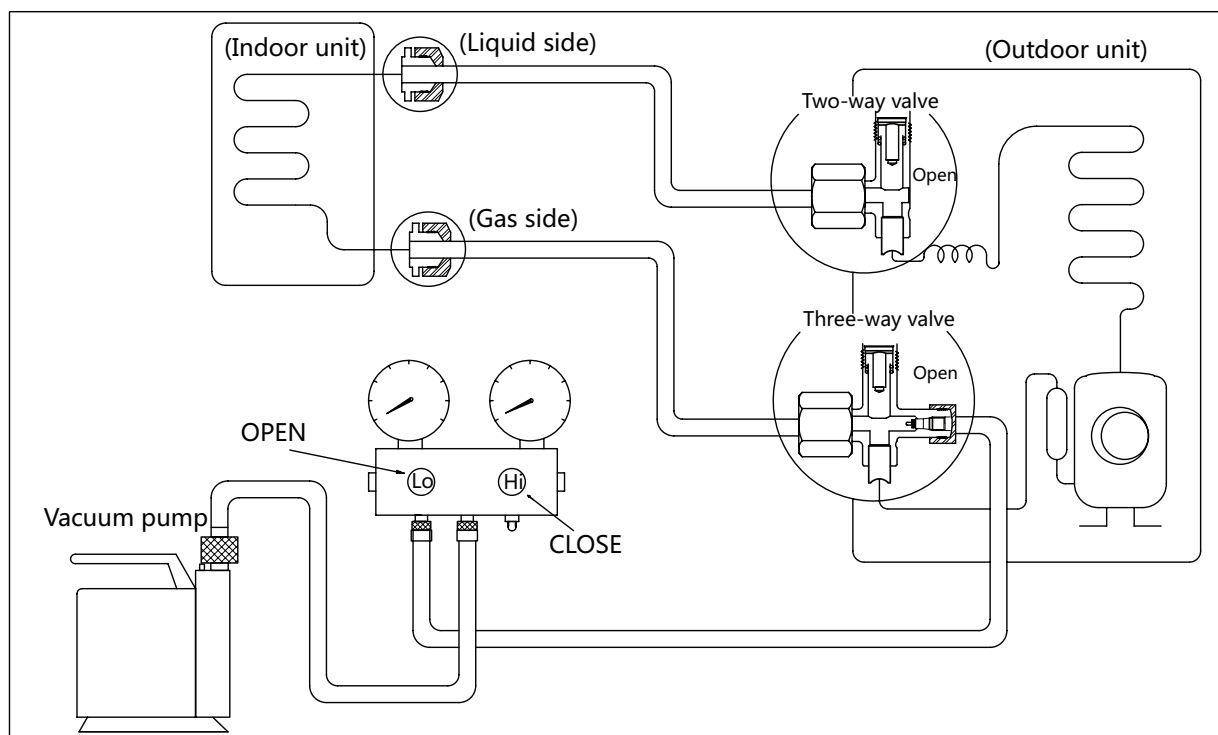

Procedure:

1. Confirm that the 2- and 3-way valves are opened.
2. Connect the vacuum pump to the 3-way valve's service port.
3. Evacuate the system for approximately one hour. Confirm that the compound meter indicates -0.1 MPa (14.5Psi).
4. Close the valve (Low side) on the charge set and turn off the vacuum pump.
5. Wait for 5 minutes then check whether the gauge needle moves after turning off the vacuum pump. If the gauge needle moves backward, check whether there is gas leakage.
6. Disconnect the charge hose from the vacuum pump.
7. Mount the caps of service port and 2- and 3-way valves.
8. Use a torque wrench to tighten the caps to a torque of 18 N.m.

Refrigerant charging

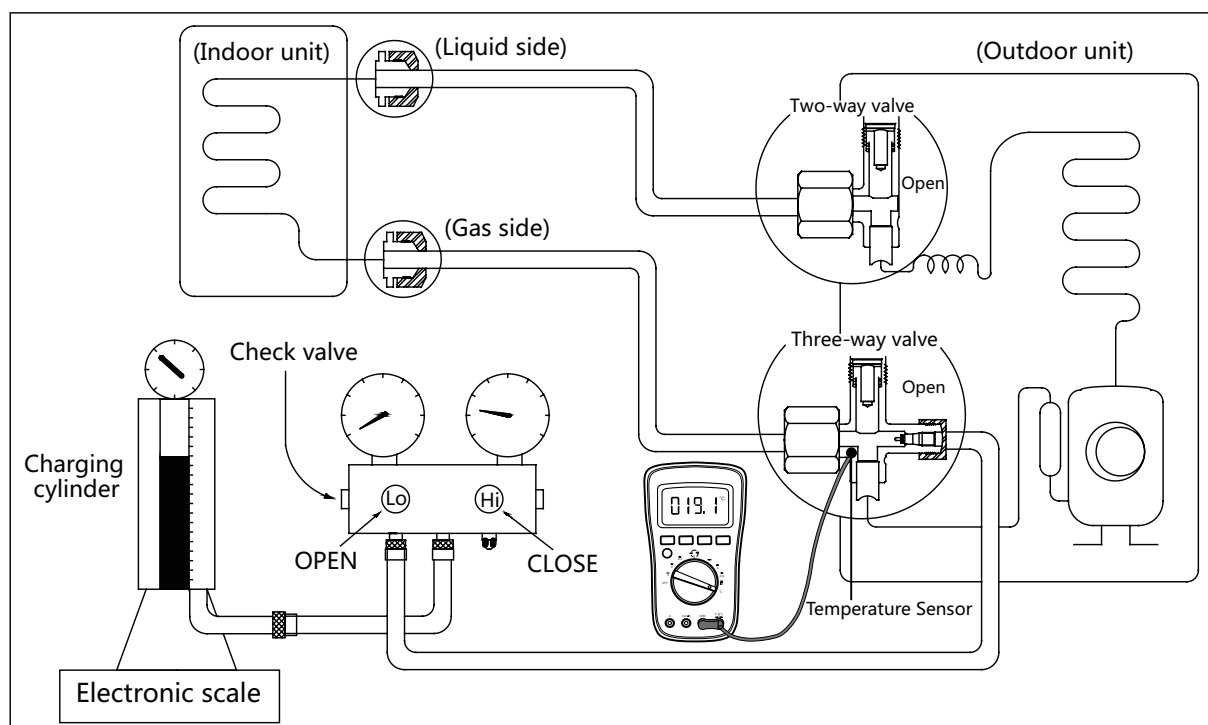

Procedure:

1. Close both 2- and 3-way valves.
2. Slightly connect the Handle Lo charge hose to the 3-way service port.
3. Connect the charge hose to the valve at the bottom of the cylinder.
4. If the refrigerant is R410A/R32, invert the cylinder to ensure a complete liquid charge.
5. Open the valve at the bottom of the cylinder for 5 seconds to purge the air in the charge hose, then fully tighten the charge hose with push pin Handle Lo to the service port of 3-way valve..
6. Place the charging cylinder onto an electronic scale and record the starting weight.
7. Fully open the Handle Lo manifold valve, 2- and 3-way valves.
8. Operate the air conditioner in cooling mode to charge the system with liquid refrigerant.
9. When the electronic scale displays the correct weight (refer to the gauge and the pressure of the low side to confirm, the value of pressure refers to chapter Appendix), turn off the air conditioner, then disconnect the charge hose from the 3-way service port immediately..
10. Mount the caps of service port and 2- and 3-way valves.
11. Use a torque wrench to tighten the caps to a torque of 18 N.m.
12. Check for gas leakage.

Note: 1. Mechanical connectors used indoors shall comply with local regulations.

2. When mechanical connectors are reused indoors, sealing parts shall be renewed. When flared joints are reused indoors, the flare part shall be re-fabricated.

Product Features

Contents

1.	Display Function	2
2.	Safety Features	3
3.	Basic Functions.....	3
3.1	Abbreviation.....	3
3.2	Fan Mode.....	3
3.3	Cooling Mode	3
3.4	Heating Mode(Heat Pump Units)	4
3.5	Auto Mode.....	5
4	Drying Mode	6
3.7	Forced Operation Function	6
3.8	Timer Function	6
3.9	Sleep Function.....	6
3.10	Auto-Restart Function.....	6
4.	Remote Controller Functions	7
4.1	LCD Wired Remote Controller	7
4.2	Centralized Controller	11

1. Display Function

Mode	Priority	G	Y1	Y/Y2	B	W	W1	W2	E/AUX	DH/DS/BK	Display
Shut down	/	0	0	0	0	0	0	0	0	*	00
Fan	7	1	0	0	*	0	0	0	0	*	01
Cooling 1	6	*	1	0	0	0	0	0	0	1	02
Cooling 2		*	*	1	0	0	0	0	0	1	03
Drying 1		*	1	0	0	0	0	0	0	0	04
Drying 2		*	*	1	0	0	0	0	0	0	05
Heating 1	5	*	1	0	1	0	0	0	0	1	06
Heating 2		*	*	1	1	0	0	0	0	1	07
Heating 2		*	*	*	*	1	0	0	0	1	
Electric heating 1	3	*	0	0	*	0	1	0	0	*	08
Electric heating 1		*	0	0	*	0	0	1	0	*	
Electric heating 2		*	0	0	*	0	1	1	0	*	09
Heating 1+Electric heating 1	4	*	1	0	1	0	1	0	0	1	10
Heating 1+Electric heating 1		*	1	0	1	0	0	1	0	1	
Heating 2 +Electric heating 1		*	*	1	1	0	1	0	0	1	
Heating 2 +Electric heating 1		*	*	*	*	1	1	0	0	1	
Heating 2 +Electric heating 1		*	*	1	1	0	0	1	0	1	
Heating 2 +Electric heating 1		*	*	*	*	1	0	1	0	1	
Heating 1+Electric heating 2	4	*	1	0	1	0	1	1	0	1	11
Heating 2+Electric heating 2		*	*	1	1	0	1	1	0	1	
Heating 2+Electric heating 2		*	*	*	*	1	1	1	0	1	
Emergency heating	1	*	*	*	*	*	*	*	1	*	12
Heating zone control	2	*	1	0	1	0	*	*	0	0	13
Heating zone control		*	*	1	1	0	*	*	0	0	
Heating zone control		*	*	*	*	1	*	*	0	0	

NOTICE:

1 : signal

0 : no signal

*: 1 or 0

If the input does not meet the above, press shutdown for processing.

2. Safety Features

Compressor three-minute delay at restart

Compressor functions are delayed for up to ten seconds upon the first startup of the unit, and are delayed for up to three minutes upon subsequent unit restarts.

Automatic shutoff based on discharge temperature

If the compressor discharge temperature exceeds a certain level for nine seconds, the compressor ceases operation.

Inverter module protection

The inverter module has an automatic shutoff mechanism based on the unit's current, voltage, and temperature. If automatic shutoff is initiated, the corresponding error code is displayed on the indoor unit and the unit ceases operation.

Indoor fan delayed operation

- When the unit starts, the indoor fan will operate after a period of setting time.
- If the unit is in heating mode, the indoor fan is regulated by the anti-cold wind function.

Compressor preheating

Preheating is automatically activated when T4 sensor is lower than setting temperature.

Sensor redundancy and automatic shutoff

- If one temperature sensor malfunctions, the air conditioner continues operation and displays the corresponding error code, allowing for emergency use.
- When more than one temperature sensor is malfunctioning, the air conditioner ceases operation.

3. Basic Functions

3.1 Abbreviation

Unit element abbreviations

Abbreviation	Element
T1	Indoor room temperature
T2	Coil temperature of evaporator
T3	Coil temperature of condenser
T4	Outdoor ambient temperature
TP	Compressor discharge temperature
TS	Setting temperature
Tsc	Adjusted setting temperature

In this manual, such as CDIFTEMP, HDIFTEMP2, TEH2, TCE1, TCE2...etc., they are well-setting parameter of EEPROM.

3.2 Fan Mode

When fan mode is activated:

- The outdoor fan and compressor are stopped.
- Temperature control is disabled and no temperature setting is displayed.
- The indoor fan speed can be set to low, medium, high, turbo and auto.
- Auto fan: In fan-only mode, AC operates the same as auto fan in cooling mode with the temperature set at 24°C(75°F).
- Under 24V control, when only G signal is available, when switching from heating mode or emergency heating mode to fan mode, $T4 < 10^{\circ}\text{C}(50^{\circ}\text{F})$, the heating mode is sent to the outdoor; when $T4 > 12^{\circ}\text{C}(54^{\circ}\text{F})$, the normal outdoor control is resumed, the fan mode is sent to the outdoor.

3.3 Cooling Mode

3.3.1 Compressor Control

- If the following conditions are satisfied, the compressor ceases operation.
 - When the frequency value calculated by the GA algorithm is negative compensation.
 - Protection time for temperature shutdown is more than ten minutes.
 - T1 is lower than or equal to (Tsc-CDIFTEMP).
- If one of the following conditions is satisfied, not judge protective time.
 - Compressor running frequency is more than test frequency.
 - When compressor running frequency is equal to test frequency, T4 is more than 15°C(59°F) or T4 fault.
 - Change setting temperature.
 - Turning on/off Turbo or Silent function.
 - Various frequency limit shutdown occurs.

3.3.2 Indoor Fan Control

- 1) In cooling mode, the indoor fan operates continuously. The fan speed can be set to low, medium, high, turbo and auto.
- 2) Auto fan action in cooling mode:
 - Descent curve
 - When T1-Tsc is lower than or equal to 3.5°C/6°F, fan speed reduces to high;
 - When T1-Tsc is lower than or equal to 1°C/2°F, fan speed reduces to medium;

- When T1-Tsc is lower than or equal to 0.5°C/1°F, fan speed reduces to low;
- Rise curve
 - When T1-Tsc is higher than 1°C/2°F, fan speed increases to medium;
 - When T1-Tsc is higher than 1.5°C/3°F, fan speed increases to high;
 - When T1-Tsc is higher than 4°C/7°F, fan speed increases to turbo.

3.3.3 Outdoor Fan Control

- The outdoor unit will be run at different fan speed according to T4 and compressor frequency.
- For different outdoor units, the fan speeds are different.

3.3.4 Condenser Temperature Protection

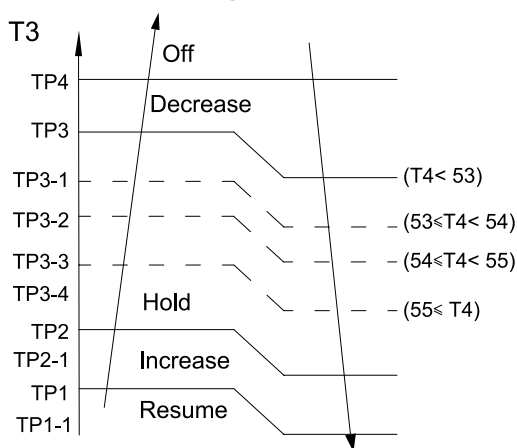

- Off: Compressor stops.
- Decrease: Decrease the running frequency to the lower level at 0.04Hz/s.
- Hold: Keep the current frequency.
- Increase: Increase the running frequency to the higher level at 1Hz/s
- Resume: No limitation for frequency.

3.3.5 Evaporator Temperature Protection

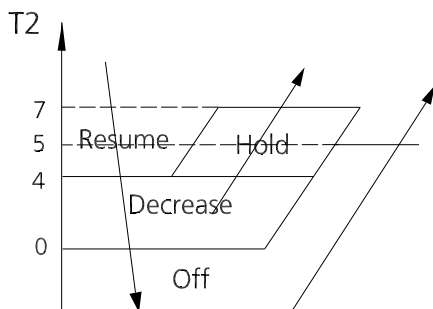

- Off: Compressor stops.
- Decrease: Decrease the running frequency to the lower level per 1 minute.

- Hold: Keep the current frequency.
- Resume: No limitation for frequency.

3.4 Heating Mode(Heat Pump Units)

3.4.1 Compressor Control

- If the following conditions are satisfied, the compressor ceases operation.
 - When the frequency value calculated by the GA algorithm is negative compensation.
 - Protection time for temperature shutdown is more than ten minutes.
 - T1 is higher than or equal to Tsc+ HDIFTEMP2.
- If one of the following conditions is satisfied, not judge protective time.
 - Compressor running frequency is more than test frequency.
 - Compressor running frequency is equal to test frequency, T4 is more than 15°C(59°F) or T4 fault.
 - Change setting temperature.
 - Turning on/off Turbo or Silent function.
- When the current is higher than the predefined safe value, surge protection is activated, causing the compressor to cease operations.

3.4.2 Indoor Fan Control:

- 1) In heating mode, the indoor fan operates continuously. The fan speed can be set to low, medium, high, turbo and auto.
- Anti-cold air function
 - The indoor fan is controlled by the indoor temperature T1 and indoor unit coil temperature T2.

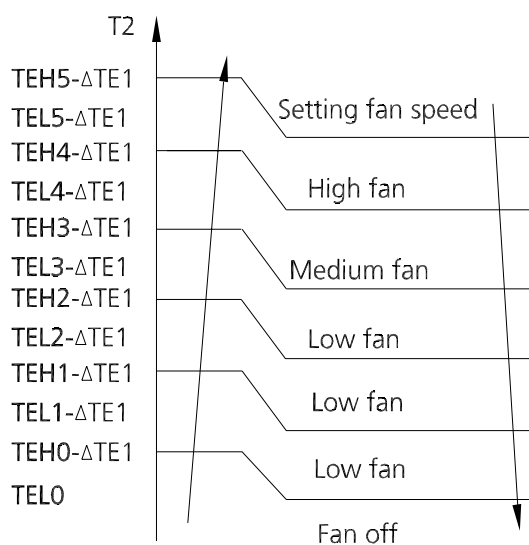

ΔTE1=0

2) Auto fan action in heating mode:

- Rise curve
 - When T1-Tsc is higher than $-1.5^{\circ}\text{C}/-3^{\circ}\text{F}$, fan speed reduces to high;
 - When T1-Tsc is higher than $0^{\circ}\text{C}/0^{\circ}\text{F}$, fan speed reduces to medium;
 - When T1-Tsc is higher than $0.5^{\circ}\text{C}/1^{\circ}\text{F}$, fan speed reduces to low;
- Descent curve
 - When T1-Tsc is lower than or equal to $0^{\circ}\text{C}/0^{\circ}\text{F}$, fan speed increases to medium;
 - When T1-Tsc is lower than or equal to $-1.5^{\circ}\text{C}/-3^{\circ}\text{F}$, fan speed increases to high;
 - When T1-Tsc is lower than or equal to $-3^{\circ}\text{C}/-5^{\circ}\text{F}$, fan speed increases to turbo.

3.4.3 Outdoor Fan Control:

- The outdoor unit will be run at different fan speed according to T4 and compressor frequency.
- For different outdoor units, the fan speeds are different.

3.4.4 Defrosting mode

- The unit enters defrosting mode according to the temperature value of T3 and T4 as well as the compressor running time.
- In defrosting mode, the compressor continues to run, the indoor and outdoor motor will cease operation, the defrost light of the indoor unit will turn on, and the "df" symbol is displayed.
- If any one of the following conditions is satisfied, defrosting ends and the machine switches to normal heating mode:
 - T3 rises above TCDE1.
 - T3 maintained above TCDE2 for 80 seconds.
 - Unit runs for 15 minutes consecutively in defrosting mode.
- If T4 is lower than or equal to $-22^{\circ}\text{C}(-8^{\circ}\text{F})$ and compressor running time is more than TIMING_DEFROST_TIME, if any one of the following conditions is satisfied, defrosting ends and the machine switches to normal heating mode:
 - Unit runs for 10 minutes consecutively in defrosting mode.
 - T3 rises above $10^{\circ}\text{C}/50^{\circ}\text{F}$.
- If any one of the following conditions is satisfied, the unit enters defrosting mode
 - If T3 or T4 is lower than $-3^{\circ}\text{C}/27^{\circ}\text{F}$ for 30 seconds, Ts-T1 is lower than $5^{\circ}\text{C}/9^{\circ}\text{F}$ and compressor running time is more than EE_TIME_DEFROST7.
 - If T3 or T4 is lower than $-3^{\circ}\text{C}/27^{\circ}\text{F}$ for 30 seconds and compressor running time is more than EE_

TIME_DEFROST7+30 minutes.

- If any one of the following conditions is satisfied, defrosting ends and the machine switches to normal heating mode:
 - T3 rises above $\text{TCDE1}+4^{\circ}\text{C}/7^{\circ}\text{F}$.
 - T3 maintained above $\text{TCDE2}+4^{\circ}\text{C}/7^{\circ}\text{F}$ for 80 seconds.
 - Unit runs for 15 minutes consecutively in defrosting mode.

3.4.5 Evaporator Coil Temperature Protection

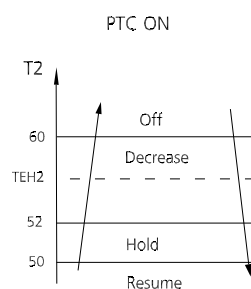
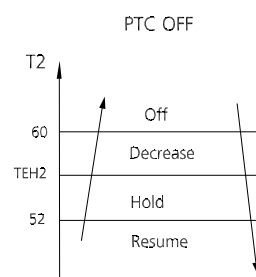

- Off: Compressor stops.
- Decrease: Decrease the running frequency to the lower level per 20 seconds.
- Hold: Keep the current frequency.
- Resume: No limitation for frequency.

3.5 Auto Mode

- This mode can be selected with the remote controller and the temperature setting can be adjusted between $16^{\circ}\text{C}\sim 30^{\circ}\text{C}(61^{\circ}\text{F}\sim 86^{\circ}\text{F})$.
- In auto mode, the machine selects cooling, heating, or fan-only mode on the basis of ΔT ($\Delta\text{T} = \text{T1}-\text{TS}$).

ΔT	Running mode
$\Delta\text{T} > 2^{\circ}\text{C}(4^{\circ}\text{F})$	Cooling
$-3^{\circ}\text{C}(-5^{\circ}\text{F}) < \Delta\text{T} \leq 2^{\circ}\text{C}(4^{\circ}\text{F})$	Fan-only
$\Delta\text{T} \leq -3^{\circ}\text{C}(-5^{\circ}\text{F})$	Heating*

Heating*: In auto mode, cooling only models run the fan

- Indoor fan will run at auto fan speed.
- If the machine switches mode between heating and

cooling, the compressor will keep stopping for certain time and then choose mode according to ΔT .

3.6 Drying Mode

- In drying mode, AC operates the same as auto fan in cooling mode.
- All protections are activated and operate the same as they do that in cooling mode.
- Low Room Temperature Protection

If the room temperature is lower than 10°C/50°F, the compressor ceases operations and does not resume until room temperature exceeds 12°C/54°F.

3.7 Forced Operation Function

Press the AUTO/COOL button, the AC will run as below sequence:

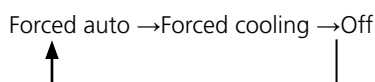

- Forced cooling mode:

The compressor and outdoor fan continue to run and the indoor fan runs at breeze speed. After running for 30 minutes, the AC will switch to auto mode with a preset temperature of 24°C(76°F).

- Forced auto mode:

Forced auto mode operates the same as normal auto mode with a preset temperature of 24°C(76°F).

- The unit exits forced operation when it receives the following signals:
 - Switch off
- Changes in:
 - mode
 - fan speed
 - sleep mode
 - Follow me

3.8 Timer Function

- The timing range is 24 hours.
- Timer On. The machine turns on automatically at the preset time.
- Timer Off. The machine turns off automatically at the preset time.
- Timer On/Off. The machine turns on automatically at the preset On Time, and then turns off automatically at the preset Off Time.
- Timer Off/On. The machine turns off automatically at the preset Off Time and then turns on automatically at the preset On Time.
- The timer does not change the unit operation mode. If the unit is off now, it does not start up immediately after the "timer off" function is set. When the setting

time is reached, the timer LED switches off and the unit running mode remains unchanged.

- The timer uses relative time, not clock time

3.9 Sleep Function

- The sleep function is available in cooling, heating, or auto mode.
- The operational process for sleep mode is as follows:
 - When cooling, the temperature rises 1°C/2°F (to not higher than 30°C/86°F) every hour. After 2 hours, the temperature stops rising and the indoor fan is fixed at low speed.
 - When heating, the temperature decreases 1°C/2°F (to not lower than 16°C/61°F) every hour. After 2 hours, the temperature stops decreasing and the indoor fan is fixed at low speed. Anti-cold wind function takes priority.
- The operating time for sleep mode is 8 hours, after which, the unit exits this mode.
- The timer setting is available in this mode.

3.10 Auto-Restart Function

- The indoor unit has an auto-restart module that allows the unit to restart automatically. The module automatically stores the current settings and in the case of a sudden power failure, will restore those setting automatically within 3 minutes after power returns.

4. Remote Controller Functions

4.1 LCD Wired Remote Controller

i) Buttons and Functions

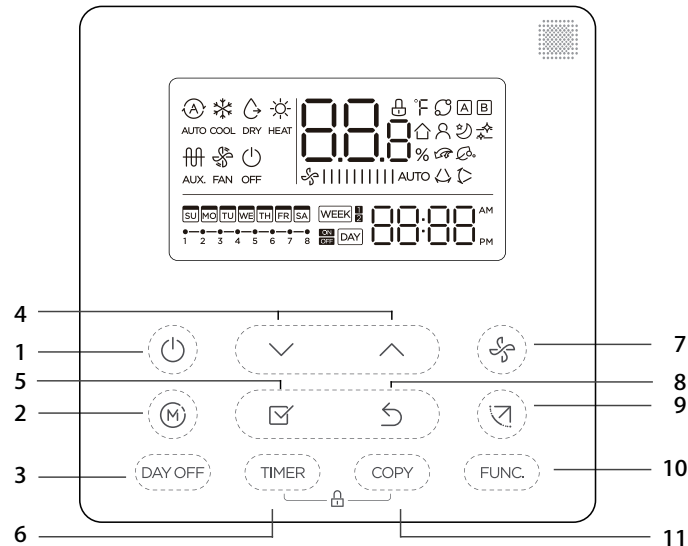

1. POWER button

Turn on or turn off the unit.

2 MODE button

Used to select the operation mode: Auto / Cooling / Drying / Heating / Fan;

3. DAY OFF/DEL button

To set 1 to 2 hours delay off for each day or a whole day off in a weekly timer schedule.

4. Adjust button

To set temperature, time and timer

5. CONFIRM button

To confirm an setting or call up the superior menu

6. TIMER button

To set timer on and timer off time of one day

7. FAN SPEED button

Used to select the fan speed.

8. BACK button

Back to previous operation or superior menu

9. Swing Button

Press to active vertical swing, hold for horizontal swing

10. FUNC. button

Press the FUNC. button to set the turbo or rotating or I feel function.

11. COPY button

To copy timer setting of one day to another in weekly schedule setting.

ii) LCD Screen

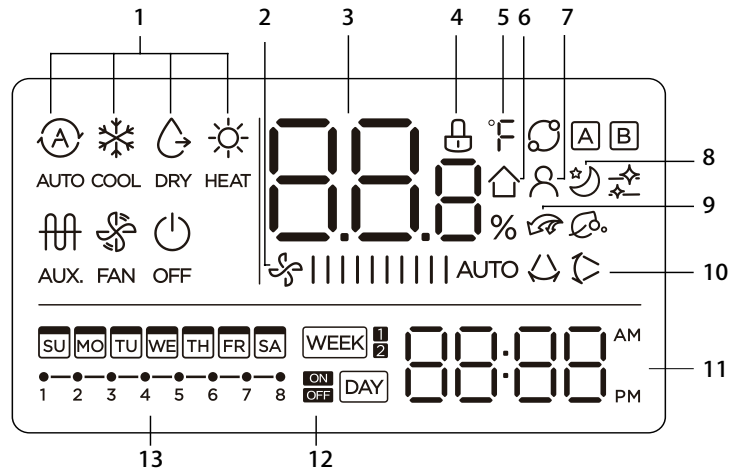

1 Operation mode indication

2 Fan speed indication

3 Temperature display

4 Lock indication

5 °C / °F indication

6 Room temperature indication

7 Follow Me function indication

8 Sleep mode indication

9 Electric Auxiliary Heat/Turbo function indication (some models)

NOTE: AHU models only have turbo functions.

10 Left-right swing indication (some models)

11 Clock display

12 On/Off timer

13 Timer display

iii) Installation

• Dimensions

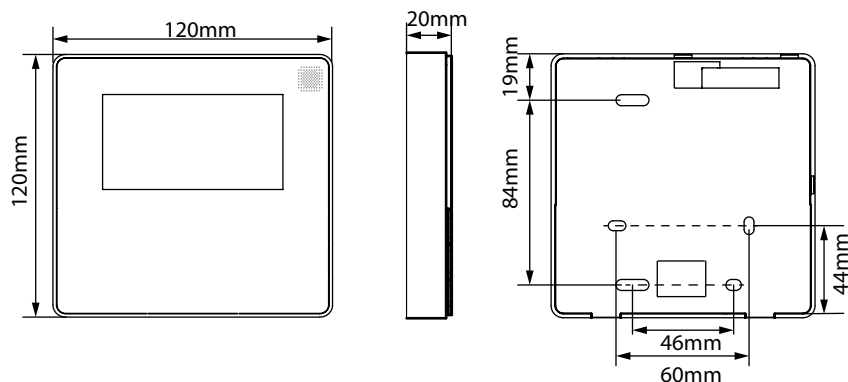

1) Connection

• Wire with the indoor unit:

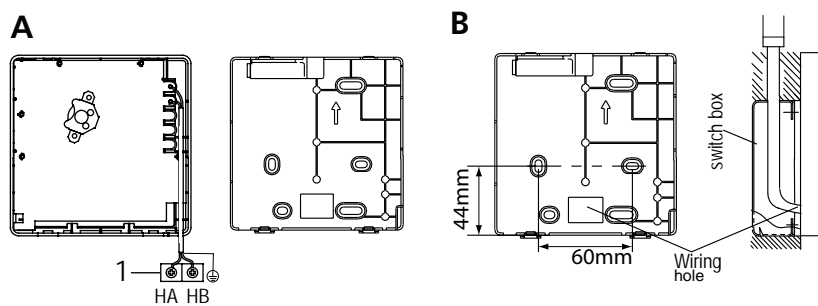

- 1: Indoor Unit.
- 2: Notch the part for the wiring to pass through with a nipper tool.
- Connect the terminals on the remote controller (HA ,HB), and the terminals of the indoor unit. (HA ,HB). (HA and HB do not have polarity.)

For some models: The wired controller connects to main control board directly.

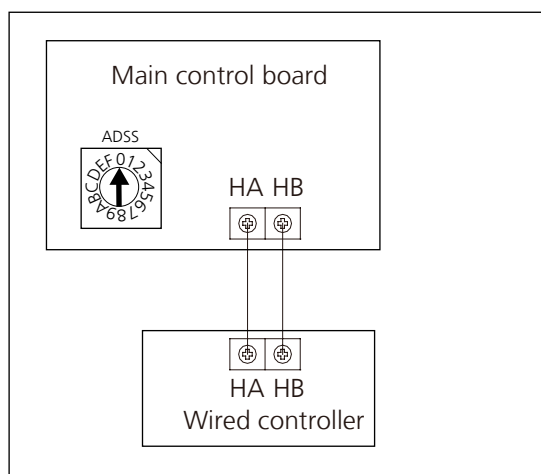

For some models: The wired controller connects to terminal board, terminal board connects to main control board.

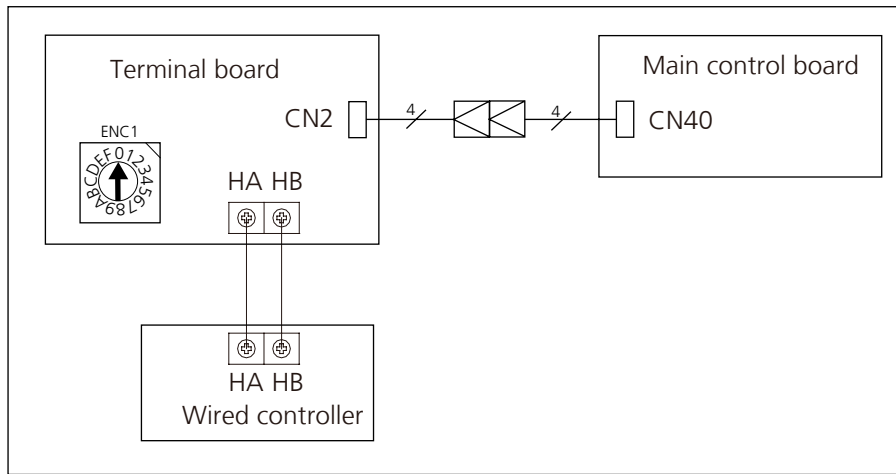

2) Address setting

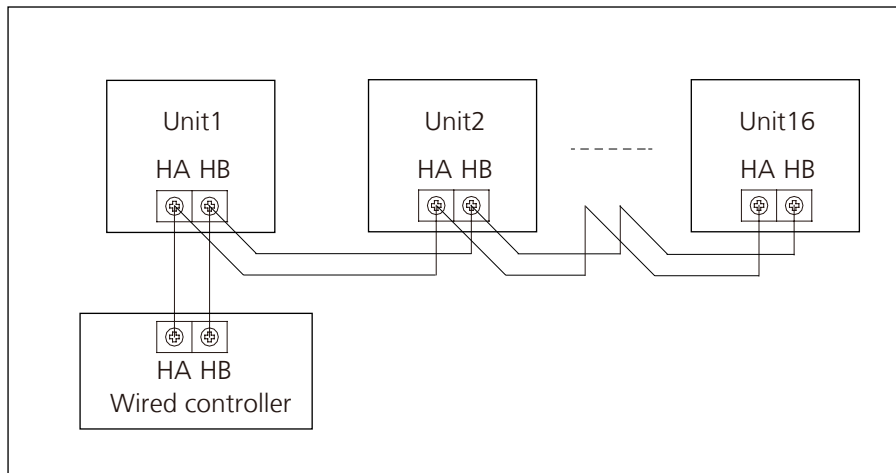

- One non-polarity controller can control up to 16 indoor units.
- When the non-polarity controller is connected to several units, every air-conditioner in network has only one network address to distinguish each other.
- Address code of air-conditioner in LAN is set by code switch ENC1(Duct and Ceiling& Floor) or ADSS(Cassette) of the indoor unit, and the set range is 0-15.
- Note: The indoor units are controlled at the same time, not independently. The purpose of setting network address is identify the unit when error occurs.

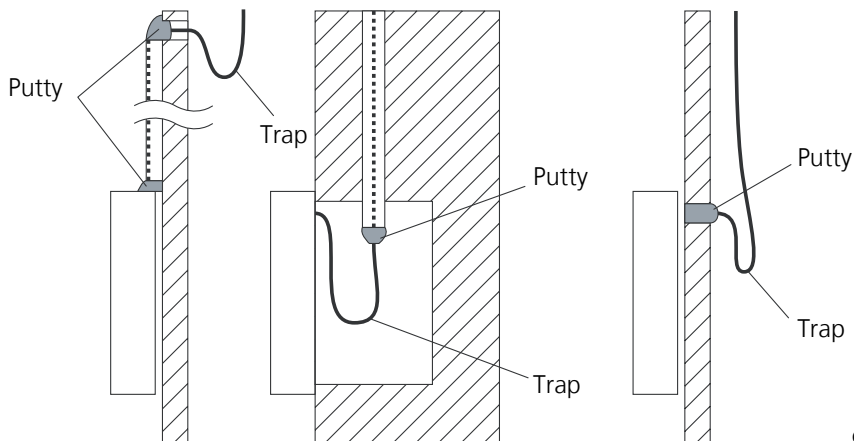

Note: DO NOT allow water to enter the remote control. Use the trap and putty to seal the wires.

4.2 Centralized Controller

1) Connection

For Light commercial air conditioner with XYE port, it can be directly connected to Centralized Controller (CCM03, CCM09).

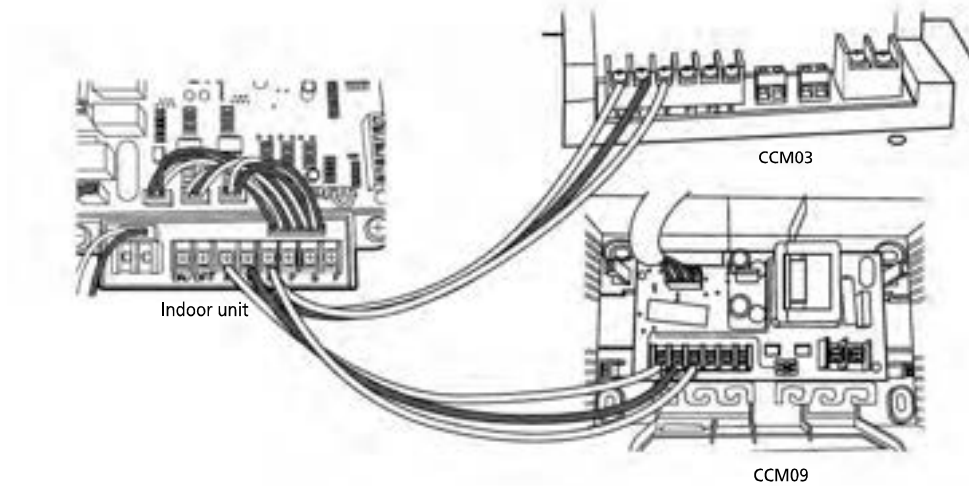

2) Address setting

When setting the address, please make sure the unit is powered off. The address can be set from 0 to 63 by the switch. Turn on the unit, then the address will be effective.

SWITCH FOR CCM UNIT ADDRESS			
S2 + S1			
ADDRESS	0~15	16~31	
Factory Setting	✓		
S2 + S1			
ADDRESS	32~47	48~63	
Factory Setting			

Note: For light commercial air conditioner with XYE port, it can be also connected to BMS (Building Management System).

If there is any CAC (central air conditioner) connecting with the central controller at the same time, please set the address from largest (63,62,61...), since the CAC units could obtain address automatically from the smallest (00,01,02...)

Troubleshooting

Contents

1.	Safety Caution	3
2.	General Troubleshooting	4
3.	Outdoor Unit Point Check Function	7
4.	Advanced Function Setting.....	9
5.	Error Diagnosis and Troubleshooting Without Error Code.....	13
	5.1 Remote maintenance.....	13
	5.2 Field maintenance	14
6.	Quick Maintenance by Error Code.....	19
7.	Troubleshooting by Error Code.....	21
	7.1 EH 00 / EC 51 (EEPROM parameter error Diagnosis and Solution)	21
	7.2 EL 01 (Indoor and outdoor unit communication error Diagnosis and Solution).....	22
	7.3 EH 03 / EC 07 (Fan speed is operating outside of the normal range)/EC 71(Over Current Failure of Outdoor DC Fan Motor)/EC 73(Zero-speed failure of outdoor DC fan motor) Diagnosis and Solution	23
	7.4 EH 60/EH 61/EC 53/EC 52/EC 54/EC 56/EC 57/EC 50/EC 5C (Open circuit or short circuit of temperature sensor diagnosis and solution)	25
	7.5 EL 0C (Refrigerant Leakage Detection Diagnosis and Solution).....	26
	7.6 EH 0E (Water-Level Alarm Malfunction Diagnosis and Solution).....	27
	7.7 PC 00 (IPM Malfunction or IGBT Over-strong Current Protection Diagnosis and Solution).....	28
	7.8 PC 01 (Over Voltage or Too Low Voltage Protection)/PC 10(Outdoor unit low AC voltage protection)/PC 11(Outdoor unit main control board DC bus high voltage protection)/PC 12(Outdoor unit main control board DC bus high voltage protection /341 MCE error) Diagnosis and Solution.....	29
	7.9 PC 04 (Inverter Compressor Drive Error Diagnosis and Solution).....	30
	7.10 PC 03/PC 31 (Low Pressure Protection Diagnosis and Solution)	31
	7.11 PC 02 (Top temperature protection of compressor or High temperature protection of IPM module Diagnosis and Solution).....	32
	7.12 EC 0d (Outdoor unit malfunction Diagnosis and Solution).....	33

Troubleshooting

Contents

7.13	PC 40(Communication error between outdoor main PCB and IPM board diagnosis and solution)	34
7.14	PC 08(Current overload protection)/PC 44(Outdoor unit zero speed protection)/PC 46(Compressor speed has been out of control)/PC 49(Compressor overcurrent failure) diagnosis and solution	35
7.15	PC 0F(PFC module protection diagnosis and solution)	37
7.16	EC 72 (Lack phase failure of outdoor DC fan motor diagnosis and solution)...	38
7.17	PC 43 (Outdoor compressor lack phase protection diagnosis and solution)...	39
7.18	PC 45 (Outdoor unit IR chip drive failure diagnosis and solution).....	40
7.19	PC 0L (Low ambient temperature protection).....	40
7.20	EC 55 (Outdoor IPM module temperature sensor fault Diagnosis and Solution)	41
7.21	PC 03/PC 30 (High pressure protection diagnosis and solution)	42
7.22	PC 0A (High temperature protection of condenser diagnosis and solution)...	44
7.23	PC 06 (Discharge temperature protection of compressor diagnosis and solution) 45	
7.24	EH 0b (Communication error between indoor two chips Diagnosis and Solution) 46	
7.25	EL 16(Communication malfunction between adapter board and outdoor main board diagnosis and solution)	47
7.26	FL 09(Indoor and outdoor mismatch malfunction diagnosis and solution) ...	47
7.27	PC 41(Outdoor compressor current sampling circuit failure diagnosis and solution)	48
7.28	EH b3 (Communication error between wired controller and indoor unit Diagnosis and Solution)	48
8.	Check Procedures	49

1. Safety Caution

! WARNING

Be sure to turn off all power supplies or disconnect all wires to avoid electric shock. While checking indoor/outdoor PCB, please equip oneself with antistatic gloves or wrist strap to avoid damage to the board.

! WARNING

Electricity remains in capacitors even when the power supply is off. Ensure the capacitors are fully discharged before troubleshooting.

Test the voltage between P and N on back of the main PCB with multimeter. If the voltage is lower than 36V, the capacitors are fully discharged. For models that cannot be measured, wait 5 minutes after the power supply is off to ensure that the capacitors are fully discharged.

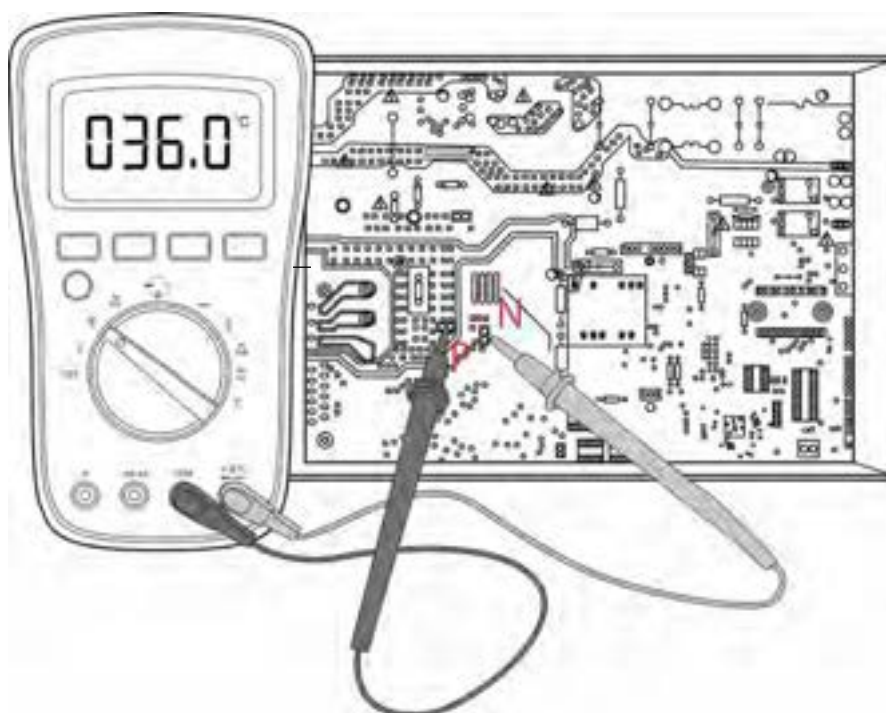

Note: This picture is for reference only. Actual appearance may vary.

2. General Troubleshooting

2.1 Error Display (Indoor Unit)

When the indoor unit encounters a recognized error, the operation lamp will flash in a corresponding series, the timer lamp may turn on or begin flashing, and an error code will be displayed. These error codes are described in the following table:

Display	Error Information	Solution
EH00	Indoor unit EEPROM parameter error	TS21
EL01	Indoor / outdoor unit communication error	TS22
EL16	Communication malfunction between adapter board and outdoor main board	TS47
EH03	The indoor fan speed is operating outside of the normal range(for some models)	TS23
EH60	Indoor room temperature sensor T1 is in open circuit or has short circuited	TS25
EH61	Evaporator coil temperature sensor T2 is in open circuit or has short circuited	TS25
EH62	Evaporator coil temperature sensor T2B is in open circuit or has short circuited	TS25
EH65	Evaporator coil temperature sensor T2A is in open circuit or has short circuited	TS25
EL0C	Refrigerant Leakage Detection	TS26
EH0b	Communication error between indoor two chips	TS46
EH0E	Water-level alarm malfunction	TS27
EC53	Outdoor room temperature sensor T4 is in open circuit or has short circuited	TS25
EC52	Condenser coil temperature sensor T3 is in open circuit or has short circuited	TS25
EC54	Compressor discharge temperature sensor TP is in open circuit or has short circuited	TS25
EC56	Evaporator coil outlet temperature sensor T2B is in open circuit or has short circuited(for free-match indoor units)	TS25
EC51	Outdoor unit EEPROM parameter error	TS21
EC07	The outdoor fan speed is operating outside of the normal range(for some models)	TS23
PC00	IPM malfunction or IGBT over-strong current protection	TS28
PC01	Over voltage or over low voltage protection	TS29
PC02	Top temperature protection of compressor or High temperature protection of IPM module	TS32
PC04	Inverter compressor drive error	TS30

PC 03	High pressure protection or low pressure protection (for some models)	TS31
EC 0d	Outdoor unit malfunction	TS33
PC 0L	Low ambient temperature protection	TS40
Fl 09	Mismatch between the new and old platforms	TS47

For other errors:

The display board may show a garbled code or a code undefined by the service manual. Ensure that this code is not a temperature reading.

Troubleshooting:

Test the unit using the remote control. If the unit does not respond to the remote, the indoor PCB requires replacement. If the unit responds, the display board requires replacement.

LED flash frequency:



2.2 Error Display on Two Way Communication Wired Controller

Display	Malfunction or Protection	Solution
EH b3	Communication error between wire controller and indoor unit	TS48

The other error codes displayed on the wire controller are same from those on the unit.

2.3 Error Display (For Some Outdoor Unit)

Display	Malfunction or Protection	Solution
EE 51	Outdoor EEPROM malfunction	TS21
EL 01	Indoor / outdoor units communication error	TS22
EL 16	Communication malfunction between adapter board and outdoor main board	TS47
PC 00	IPM module protection	TS28
PC 02	Top temperature protection of compressor or High temperature protection of IPM module	TS32
PC 06	Temperature protection of compressor discharge	TS45
PC 08	Outdoor overcurrent protection	TS35
PC 0A	High temperature protection of condenser	TS44
PC 0F	PFC module protection	TS37
PC 10	Outdoor unit low AC voltage protection	TS29
PC 11	Outdoor unit main control board DC bus high voltage protection	TS29
PC 12	Outdoor unit main control board DC bus high voltage protection /341 MCE error	TS29
PC 30	High pressure protection	TS42
PC 31	Low pressure protection	TS31
PC 40	Communication malfunction between IPM board and outdoor main board	TS34
PC 41	Outdoor compressor current sampling circuit failure	TS48
PC 43	Outdoor compressor lack phase protection	TS39
PC 44	Outdoor unit zero speed protection	TS35
PC 45	Outdoor unit IR chip drive failure	TS40
PC 46	Compressor speed has been out of control	TS35
PC 49	Compressor overcurrent failure	TS35
EE 52	Condenser coil temperature sensor T3 is in open circuit or has short circuited	TS25
EE 53	Outdoor room temperature sensor T4 is in open circuit or has short circuited	TS25
EE 54	Compressor discharge temperature sensor TP is in open circuit or has short circuited	TS25
EE57	Refrigerant pipe temperature sensor error	TS25
EE 5C	High pressure sensor is in open circuit or has short circuited	TS25
EE 71	Over current failure of outdoor DC fan motor	TS25
EE 72	Lack phase failure of outdoor DC fan motor	TS38
EE 73	Zero-speed failure of outdoor DC fan motor	TS23
EE 07	Outdoor fan speed has been out of control	TS23
PC 0L	Low ambient temperature protection	TS40
LC 06	High temperature protection of IPM module	TS32
EE 55	Outdoor IPM module temperature sensor fault	TS41
PH 90	High temperature protection of evaporator	--
PH 91	Low temperature protection of evaporator	--

3. Outdoor Unit Point Check Function

- A check switch is included on the outdoor PCB.
- Push SW1 to check the unit's status while running. The digital display shows the following codes each time the SW1 is pushed.

Number of Presses	Display	Remark
00	Normal display	Displays running frequency, running state, or malfunction code Defrosting mode: "dF" or alternative displays between running frequency and "dF" (each appears for 0.5s.) Forced cooling mode: the LED displays "FC" or alternative displays between running frequency and "FC" (each appears for 0.5s).
01	Indoor unit capacity demand code	Actual data*HP*10 If capacity demand code is higher than 99, the digital display tube will show single digit and tens digit. (For example, the digital display tube show "5.0",it means the capacity demand is 15. the digital display tube show "60",it means the capacity demand is 6.0) GA algorithm models display "--"
02	The frequency after the capacity requirement adapter	If the value is higher than 99, the digital display tube will show single digit and tens digit.
03	Room temperature (T1)	If the temp. is lower than 0 degree, the digital display tube will show "0".If the temp. is higher than 70 degree, the digital display tube will show "70".
04	Indoor unit evaporator temperature (T2)	If the temp. is lower than -9 degree, the digital display tube will show "-9".If the temp. is higher than 70 degree, the digital display tube will show "70". If the indoor unit is not connected, the digital display tube will show: "--"
05	Condenser pipe temp.(T3)	
06	Outdoor ambient temp.(T4)	
07	Compressor discharge temp. (TP)	The display value is between 0~199 degree. If the temp. is lower than 0 degree, the digital display tube will show "0". If the temp. is higher than 99 degree, the digital display tube will show single digit and tens digit. (For example, the digital display tube show "0.5",it means the compressor discharge temp. is 105 degree. the digital display tube show "1.6",it means the compressor discharge temp. is 116 degree)
08	AD value of current	The display value is a hex number.
09	AD value of voltage	For example, the digital display tube shows "Cd", it means AD value is 205.
10	Indoor unit running mode code	Standby:0,Cooling:1, Heating:2, Fan only 3, Drying:4, Forced cooling:6, Defrost:7
11	Outdoor unit running mode code	
12	EXV open angle	Actual data/4. If the value is higher than 99, the digital display tube will show single digit and tens digit. For example, the digital display tube show "2.0",it means the EXV open angle is 120×4=480p.)

13	Frequency limit symbol	Bit7	Frequency limit caused by IGBT radiator	The display value is a hex number. For example, the digital display show 2A, then Bit5=1, Bit3=1, and Bit1=1. This means that a frequency limit may be caused by T4, T3, or the current.
		Bit6	Reserved	
		Bit5	Reserved	
		Bit4	Frequency limit caused by low temperature of T2.(LH00)	
		Bit3	Frequency limit caused by T3.(LC01)	
		Bit2	Frequency limit caused by TP.(LC02)	
		Bit1	Frequency limit caused by current(LC03)	
		Bit0	Frequency limit caused by voltage (LC05)	
14	Outdoor unit fan speed	If it is higher than 99, the digital display tube will show single digit and tens digit. (For example, the digital display tube show "2.0",it means the fan speed is 120.) This value is multiplied by 8, and it is the current fan speed: 120*8=960		
15	The average value of the temperature values detected by the high and low pressure sensors in the last 10 seconds of the compressor frequency calculation period	The displayed value is the actual value plus 60 (that is, when the displayed value is 10, the actual value is -50). When the displayed value is higher than 99, the digital display tube will show single digit and tens digit. (if it displays 2.0, it means 120)		
16	The temperature value detected by the high and low pressure sensor	When there is no pressure sensor, it is displayed as --		
17	AD value detected by the high and low pressure sensor	The display value is a hex number. For example, the digital display tube shows "Cd", it means AD value is 205. When there is no pressure sensor, it is displayed as --		
18	The currently running communication protocol version	00-99		

4. Advanced Function Setting

In order to enter to the engineering mode, and check the advanced function settings, Please make the following steps:

If you want to check the current functions set value (Presetting Page):

- 1- Firstly, you need to disconnect the power supply from the unit, and wait for 1 minute.
- 2- Then connect the power supply again to the unit (the unit should be under the standby state).
- 3- Press "Power" + "Fan" buttons together for 7s until the remote controller screen shows "0", and also "Auto, Cool, Dry, Heat, Battery " icons will be displayed at the same time.
- 4- Press "Up" or "Down" button to choose different channel number that you want to check (from 0-30) on the remote controller.
- 5- Then Press "Power" button for 2s until the remote controller screen shows "Ch" .
- 6- Press "OK" button to query the current function set value while the remote controller shows "CH", and the function set value will be shown on the indoor unit display.

If you want to change the current functions set value:

- 1- Firstly, you need to disconnect the power supply from the unit, and wait for 1 minute.
- 2- Then connect the power supply again to the unit (the unit should be under the standby state).
- 3- Press "Power" + "Fan" buttons together for 7s until the remote controller screen shows "0", and also "Auto, Cool, Dry, Heat, Battery " icons will be displayed at the same time.
- 4- Press "Up" or "Down" button to choose different channel number that you want to change (from 0-30) on the remote controller.
- 5- Then Press "Power" button for 2s until the remote controller screen shows "Ch" .
- 6- Press "Up" or "Down" button to choose the desired set value from the screen of the remote control.
- 7- Then Press "OK" to send the new set value to the indoor unit, and the indoor unit will display "CS", which means that the new set value is uploaded successfully.
- 8- Finally, disconnect the power supply again from the unit, and wait for 10 minutes, then connect it again.

Please note that:

- 1- The Channel number indicates a certain function, and each number will be showed on the indoor unit screen indicates the current function set value (Check the below table).
- 2- In the engineering mode, the other keys or operations are invalid except for the following buttons "Power", "Up", "Down" , and "Ok".
- 3- In order to set a new set value successfully, you need to finish the steps (from 2 to 7) within 1 minute only.
- 4- The engineering mode will be exited if there is no valid input data for 60s.
- 5- In order to exit from the engineering mode, Pleas follow the following steps:
 - Press "Power" button for 2s press until the remote controller screen shows "0".
 - Then Press "Power" + "Fan" buttons together for 2s to quit the engineering mode and back to the home screen.

Channel	Function	Parameter Value Meaning	Remark
0	Capacity setting (Btu/h)	1-100K	
1	Auto-restart function	0 – Inactive 1 – Active	
2	Fan control when Ts reached	1- Fan stop 2 - Fan runs at lowest RPM 3 - Fan runs at setting RPM 4 - Fan stops for 4 mins and runs for 1mins 5 - Fan stops for 8 mins and runs for 1mins 6 - Fan stops for 16 mins and runs for 1mins 7 - Fan stops for 24 mins and runs for 1mins 8 - Fan stops for 48 mins and runs for 1mins 9 - Fan stops for 15 mins and runs for 2.5mins 10 - Fan stops for 30 mins and runs for 2.5mins 11 - Fan stops for 60 mins and runs for 2.5 12- Fan runs at setting RPM, but stop if choose Automatic speed 13- Fan runs at the lowest speed, but stop if choose Automatic speed	
3	Mode lock	CH–Cooling and heating (all modes) HH–Heating only (Heating + Fan only) CC–Cooling only (Cooling + Drying + Fan only) nU–Cooling and heating without Auto	Remote controller will change as well.
4	Lowest setting temperature	16-24	Remote controller will change as well.
5	Highest setting temperature	25-30	Remote controller will change as well.
6	Reserved	Nothing to set	
7	/	Nothing to set	
8	/	Nothing to set	
9	/	Nothing to set	
10	/	Nothing to set	
11	Min. frequency limitation in cooling mode	10, 11, 12, ..., 49, 50, -- (Cancel)	
12	Min. frequency limitation in heating mode	10, 11, 12, ..., 49, 50, -- (Cancel)	
13	Max frequency selection in T4 limitation of Zone6	20, 21, 22, ..., 149, 150, -- (Cancel)	
14	/	Nothing to set	
15	Frequency selection of outdoor forced-operation	10, 11, 12, ..., 249, 250, -- (Cancel)	
16	One button reset	rS – Reset	

17	nA	Nothing to set	
18	Capacity setting(kW)	23,26,32,35,51,72,120,-- (Cancel)	
19	Max. frequency selection in cooling mode	40, 41, 42, ..., 83, 84, -- (Cancel)	
20	Max. frequency selection in heating mode	40, 41, 42, ..., 83, 84, -- (Cancel)	Without limitation
21	Cooling temperature compensation	-3.0, -2.5, -2.0, ..., 3.0, 3.5, -- (Cancel)	
22	Heating temperature compensation	-6.5, -6.0, -5.5, ..., 0.5, 1.0, 1.5, ..., 7.0, 7.5, -- (Cancel)	
23	Fan volume selection in cooling	Fan volume will add set data*20cfm.	
24	Reserved	Nothing to set	
25	Fan volume selection in heating	Fan volume will add set data*20cfm.	
26	Reserved	Nothing to set	
27	Defrosting type	A0-Normal defrosting A1-Enhanced defrosting	
28	Anti-cold air Stop Fan Temperature	16~28	
29	Reserved	Nothing to set	
30	Reserved	Nothing to set	

Error code of engineer mode

Display	Error Information
E _H 00	Indoor unit EEPROM parameter error
E _L 01	Indoor / outdoor unit communication error
E _L 16	Communication malfunction between adapter board and outdoor main board
E _H 03	The indoor fan speed is operating outside of the normal range
E _C 51	Outdoor unit EEPROM parameter error
E _C 52	Condenser coil temperature sensor T3 is in open circuit or has short circuited
E _C 53	Outdoor room temperature sensor T4 is in open circuit or has short circuited
E _C 54	Compressor discharge temperature sensor TP is in open circuit or has short circuited
E _C 55	IGBT temperature sensor TH is in open circuit or has short circuited
E _C 56	Evaporator coil outlet temperature sensor T2B is in open circuit or has short circuited(for free-match indoor units)
E _C 0d	Outdoor unit malfunction
E _H 60	Indoor room temperature sensor T1 is in open circuit or has short circuited
E _H 61	Evaporator coil temperature sensor T2 is in open circuit or has short circuited
E _H 62	Evaporator coil temperature sensor T2B is in open circuit or has short circuited
E _H 65	Evaporator coil temperature sensor T2A is in open circuit or has short circuited
E _C 07	The outdoor fan speed is operating outside of the normal range(
E _H 0b	Communication error between indoor two chips
E _L 0c	Refrigerant leak detected
E _H 0E	Water-level alarm malfunction
P _L 09	Mismatch between the new and old platforms
P _C 00	IPM malfunction or IGBT over-strong current protection
P _C 01	Over voltage or over low voltage protection
P _C 02	Top temperature protection of compressor or High temperature protection of IPM module
P _C 04	Inverter compressor drive error
P _C 08	Outdoor current protection
P _C 03	Pressure protection
P _C 0L	Outdoor low ambient temperature protection
P _H 90	Evaporator coil temperature over high protection
P _H 91	Evaporator coil temperature over low Protection
P _C 0R	Condenser high temperature protection

5. Error Diagnosis and Troubleshooting Without Error Code

WARNING

Be sure to turn off unit before any maintenance to prevent damage or injury.

5.1 Remote maintenance

SUGGESTION: When troubles occur, please check the following points with customers before field maintenance.

No.	Problem	Solution
1	Unit will not start	TS15 - TS16
2	The power switch is on but fans will not start	TS15 - TS16
3	The temperature on the display board cannot be set	TS15 - TS16
4	Unit is on but the wind is not cold(hot)	TS15 - TS16
5	Unit runs, but shortly stops	TS15 - TS16
6	The unit starts up and stops frequently	TS15 - TS16
7	Unit runs continuously but insufficient cooling(heating)	TS15 - TS16
8	Cool can not change to heat	TS15 - TS16
9	Unit is noisy	TS15 - TS16

5.2 Field maintenance

	Problem	Solution
1	Unit will not start	TS17 - TS18
2	Compressor will not start but fans run	TS17 - TS18
3	Compressor and condenser (outdoor) fan will not start	TS17 - TS18
4	Evaporator (indoor) fan will not start	TS17 - TS18
5	Condenser (Outdoor) fan will not start	TS17 - TS18
6	Unit runs, but shortly stops	TS17 - TS18
7	Compressor short-cycles due to overload	TS17 - TS18
8	High discharge pressure	TS17 - TS18
9	Low discharge pressure	TS17 - TS18
10	High suction pressure	TS17 - TS18
11	Low suction pressure	TS17 - TS18
12	Unit runs continuously but insufficient cooling	TS17 - TS18
13	Too cool	TS17 - TS18
14	Compressor is noisy	TS17 - TS18

1.Remote Maintenance	Electrical Circuit					Refrigerant Circuit								
Possible causes of trouble	Power failure.	The main power tripped	Loose connections	Faulty transformer	The voltage too high or too low	The remote control is powered off	Broken the remote control	Dirty air filter	Dirty condenser fins	The setting temperature is higher/lower than the room's (cooling/heating)	The ambient temperature is too high/low when the mode is cooling/heating	Fan mode	SILENCE function is activated(Optional function)	Frosting and defrosting frequently
Unit will not start.	☆	☆	☆	☆										
The power switch is on but fans will not start			☆	☆	☆									
The temperature on the playboard cannot be setted						☆	☆							
Unit is on but the wind is not cold(hot)										☆	☆	☆		
Unit runs, but shortly stops					☆					☆	☆			
The unit startup and stop frequently					☆						☆			☆
Unit runs continuously but insufficient cooling(heating)								☆	☆	☆	☆		☆	
Cool can not change to heat														
Unit is noisy														
Test method / remedy	Test voltage	Close the power switch	Inspect connections - tighten	Change the transformer	Test voltage	Replace the battery of the remote control	Replace the remote control	Clean or replace	Clean	Adjust the setting temperature	Turn on the AC later	Adjust to cool mode	Turn off the SILENCE function	Turn on the AC later

1.Remote Maintenance	Others					
Possible causes of trouble	Heavy load condition	Loosen hold down bolts and / or screws	Bad airproof	The air inlet or outlet of either unit is blocked	Interference from cell phone towers and remote boosters	Shipping plates remain attached
Unit will not start						
The power switch is on but fans will not start					☆	
The temperature on the display board cannot be set						
Unit is on but the wind is not cold(hot)						
Unit runs, but shortly stops						
The unit starts up and stops frequently				☆		
Unit runs continuously but insufficient cooling(heating)	☆		☆	☆		
Cool can not change to heat						
Unit is noisy		☆				☆
Test method / remedy	Check heat load	Tighten bolts or screws	Close all the windows and doors	Remove the obstacles	Reconnect the power or press ON/OFF button on remote control to restart operation	Remove them

2.Field Maintenance	Refrigerant Circuit															Others								
Possible causes of trouble	Compressor stuck	Shortage of refrigerant	Restricted liquid line	Dirty air filter	Dirty evaporator coil	Insufficient air through evaporator coil	Overcharge of refrigerant	Dirty or partially blocked condenser	Air or incompressible gas in refrigerant cycle	Short cycling of condensing air	High temperature condensing medium	Insufficient condensing medium	Broken compressor internal parts	Inefficient compressor	Expansion valve obstructed	Expansion valve or capillary tube closed completely	Leaking power element on expansion valve	Poor installation of feeler bulb	Heavy load condition	Loosen hold down bolts and / or screws	Shipping plates remain attached	Poor choices of capacity	Contact of piping with other piping or external plate	
Unit will not start																								
Compressor will not start but fans run	☆																							
Compressor and condenser (outdoor) fan will not start																								
Evaporator (indoor) fan will not start																								
Condenser (Outdoor) fan will not start																								
Unit runs, but shortly stops		☆	☆				☆	☆								☆	☆							
Compressor short-cycles due to overload		☆					☆	☆																
High discharge pressure							☆	☆	☆	☆	☆	☆												
Low discharge pressure		☆												☆										
High suction pressure							☆							☆				☆	☆					
Low suction pressure		☆	☆	☆	☆	☆								☆	☆	☆								
Unit runs continuously but insufficient cooling		☆	☆	☆	☆	☆		☆	☆	☆				☆					☆			☆		
Too cool																								
Compressor is noisy							☆						☆							☆	☆		☆	
Test method / remedy	Replace the compressor	Leak test	Replace restricted part	Clean or replace	Clean coil	Check fan	Change charged refrigerant volume	Clean condenser or remove obstacle	Purge, evacuate and recharge	Remove obstruction to air flow	Remove obstruction in air or water flow	Remove obstruction in air or water flow	Replace compressor	Test compressor efficiency	Replace valve	Replace valve	Replace valve	Fix feeler bulb	Check heat load	Tighten bolts or screws	Remove them	Choose AC of larger capacity or add the number of AC	Rectify piping so as not to contact each other or with external plate	

2.Field Maintenance	Electrical Circuit														
Possible causes of trouble	Power failure	Blown fuse or varistor	Loose connections	Shorted or broken wires	Safety device opens	Faulty thermostat / room temperature sensor	Wrong setting place of temperature sensor	Faulty transformer	Shorted or open capacitor	Faulty magnetic contactor for compressor	Faulty magnetic contactor for fan	Low voltage	Faulty stepping motor	Shorted or grounded compressor	Shorted or grounded fan motor
Unit will not start	☆	☆	☆	☆	☆			☆							
Compressor will not start but fans run				☆		☆			☆	☆				☆	
Compressor and condenser (outdoor) fan will not start				☆		☆				☆					
Evaporator (indoor) fan will not start				☆					☆		☆				☆
Condenser (Outdoor) fan will not start				☆		☆			☆		☆				☆
Unit runs, but shortly stops										☆		☆			
Compressor short-cycles due to overload										☆		☆			
High discharge pressure															
Low discharge pressure															
High suction pressure															
Low suction pressure															
Unit runs continuously but insufficient cooling															
Too cool						☆	☆								
Compressor is noisy															
Test method / remedy	Test voltage	Inspect fuse type & size	Inspect connections - tighten	Test circuits with tester	Test continuity of safety device	Test continuity of thermostat / sensor & wiring Place the temperature sensor at the central of the air inlet grille	Check control circuit with tester	Check capacitor with tester	Test continuity of coil & contacts	Test continuity of coil & contacts	Test voltage	Replace the stepping motor	Check resistance with multimeter	Check resistance with multimeter	

6. Quick Maintenance by Error Code

If you do not have the time to test which specific parts are faulty, you can directly change the required parts according to the error code.

You can find the parts to replace by error code in the following table.

Part requiring replacement	Error Code									
	E400	E401	E403	E460	E461	E462	E465	E40C	E40E	EC53
Indoor PCB	✓	✓	✓	✓	✓	✓	✓	✓	✓	x
Outdoor PCB	x	✓	x	x	x	x	x	x	x	✓
Indoor fan motor	x	x	✓	x	x	x	x	x	x	x
T1 sensor	x	x	x	✓	x	x	x	x	x	x
T2 Sensor	x	x	x	x	✓	x	x	x	x	x
T2B Sensor	x	x	x	x	x	✓	x	x	x	x
T2A Sensor	x	x	x	x	x	x	✓	x	x	x
T3 Sensor	x	x	x	x	x	x	x	x	x	x
T4 Sensor	x	x	x	x	x	x	x	x	x	✓
Reactor	x	✓	x	x	x	x	x	x	x	x
Compressor	x	x	x	x	x	x	x	x	x	x
Additional refrigerant	x	x	x	x	x	x	x	✓	x	x
Water-level switch	x	x	x	x	x	x	x	x	✓	x
Water pump	x	x	x	x	x	x	x	x	✓	x

Part requiring replacement	EC54	EC51	EC5C	EC52	EC 01/11 /12/13	PC00	PC01	PC02	PC04	PC03
Indoor PCB	x	x	x	x	x	x	x	x	x	x
Outdoor PCB	✓	✓	✓	✓	✓	✓	✓	✓	✓	✓
Outdoor fan motor	x	x	x	x	✓	✓	x	✓	✓	x
T3 Sensor	x	x	x	✓	x	x	x	x	x	x
TP Sensor	✓	x	x	x	x	x	x	x	x	x
Pressure sensor	x	x	✓	x	x	x	x	x	x	x
Reactor	x	x	x	x	x	x	✓	x	x	x
Compressor	x	x	x	x	x	✓	x	x	✓	x
IPM module board	x	x	x	x	x	✓	✓	✓	✓	x
Low pressure protector	x	x	x	x	x	x	x	x	x	✓
Additional refrigerant	x	x	x	x	x	x	x	x	x	✓

Part requiring replacement	EU 16	EM 0b	PC 06	PC 08/44/49	PC 0A	PC 0F
Indoor PCB	x	✓	x	x	x	x
Outdoor PCB	✓	x	✓	✓	✓	✓
Outdoor fan motor	x	x	x	✓	✓	x
T3 Sensor	x	x	x	x	✓	x
TP Sensor	x	x	✓	x	x	x
Pressure sensor	x	x	x	x	x	x
Reactor	x	x	x	✓	x	✓
Compressor	x	x	x	x	x	x
IPM module board	x	x	x	✓	x	x
Data adapter board	✓	✓	x	x	x	x
High pressure valve assy	x	x	✓	x	x	x
High pressure protector	x	x	x	x	x	x
Low pressure protector	x	x	x	x	x	x
Additional refrigerant	x	x	✓	x	✓	x

Part requiring replacement	PC 41	PC 43	PC 10/11/12	PC 30	PC 31	PC 40
Indoor PCB	x	x	x	x	x	x
Outdoor PCB	✓	✓	✓	✓	✓	✓
Outdoor fan motor	x	x	x	✓	x	x
T3 Sensor	x	x	x	x	x	x
TP Sensor	x	x	x	x	x	x
Pressure sensor	x	x	x	x	x	x
Reactor	x	x	✓	x	x	x
Compressor	x	✓	x	x	x	x
IPM module board	x	x	✓	x	x	✓
Data adapter board	x	x	x	x	x	x
High pressure valve assy	x	x	x	x	x	x
High pressure protector	x	x	x	✓	x	x
Low pressure protector	x	x	x	x	✓	x
Additional refrigerant	x	x	x	x	✓	x
Electric control box	x	x	x	x	x	✓

7. Troubleshooting by Error Code

7.1 EH 00 / EC 51 (EEPROM Parameter Error Diagnosis and Solution)

Description: Indoor or outdoor PCB main chip does not receive feedback from EEPROM chip.

Recommended parts to prepare:

- Indoor PCB
- Outdoor PCB

Troubleshooting and repair:

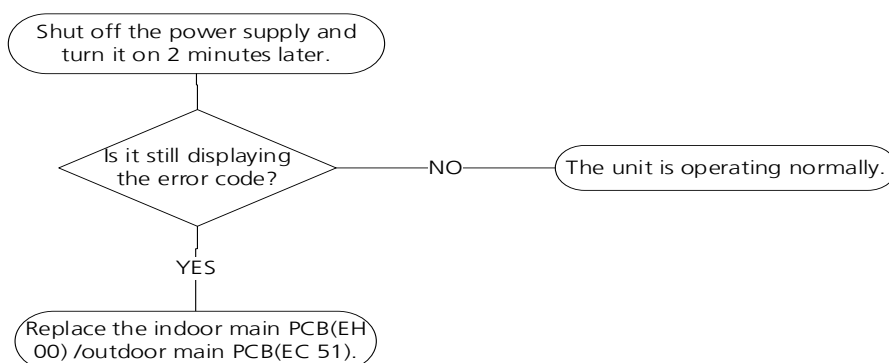

Remarks:

EEPROM: A read-only memory whose contents can be erased and reprogrammed using a pulsed voltage.

The location of the EEPROM chip on the indoor and outdoor PCB is shown in the following two images:

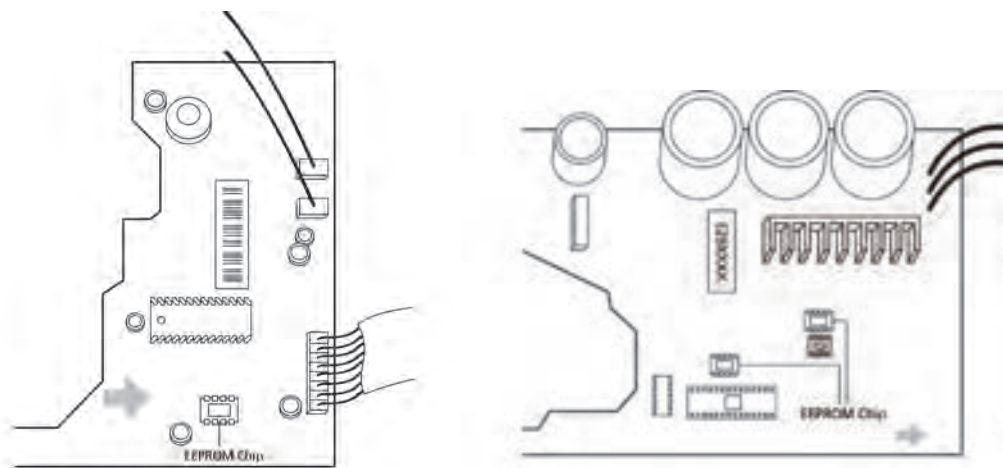

This pictures are only for reference, actual appearance may vary.

Troubleshooting and repair of compressor driven chip EEPROM parameter error and communication error between outdoor main chip and compressor driven chip are same as EC 51.

7.2 EL 01 (Indoor and Outdoor Unit Communication Error Diagnosis and Solution)

Description: Indoor unit can not communicate with outdoor unit

Recommended parts to prepare:

- Signal wires
- Magnet ring
- Indoor PCB
- Outdoor PCB

Troubleshooting and repair:

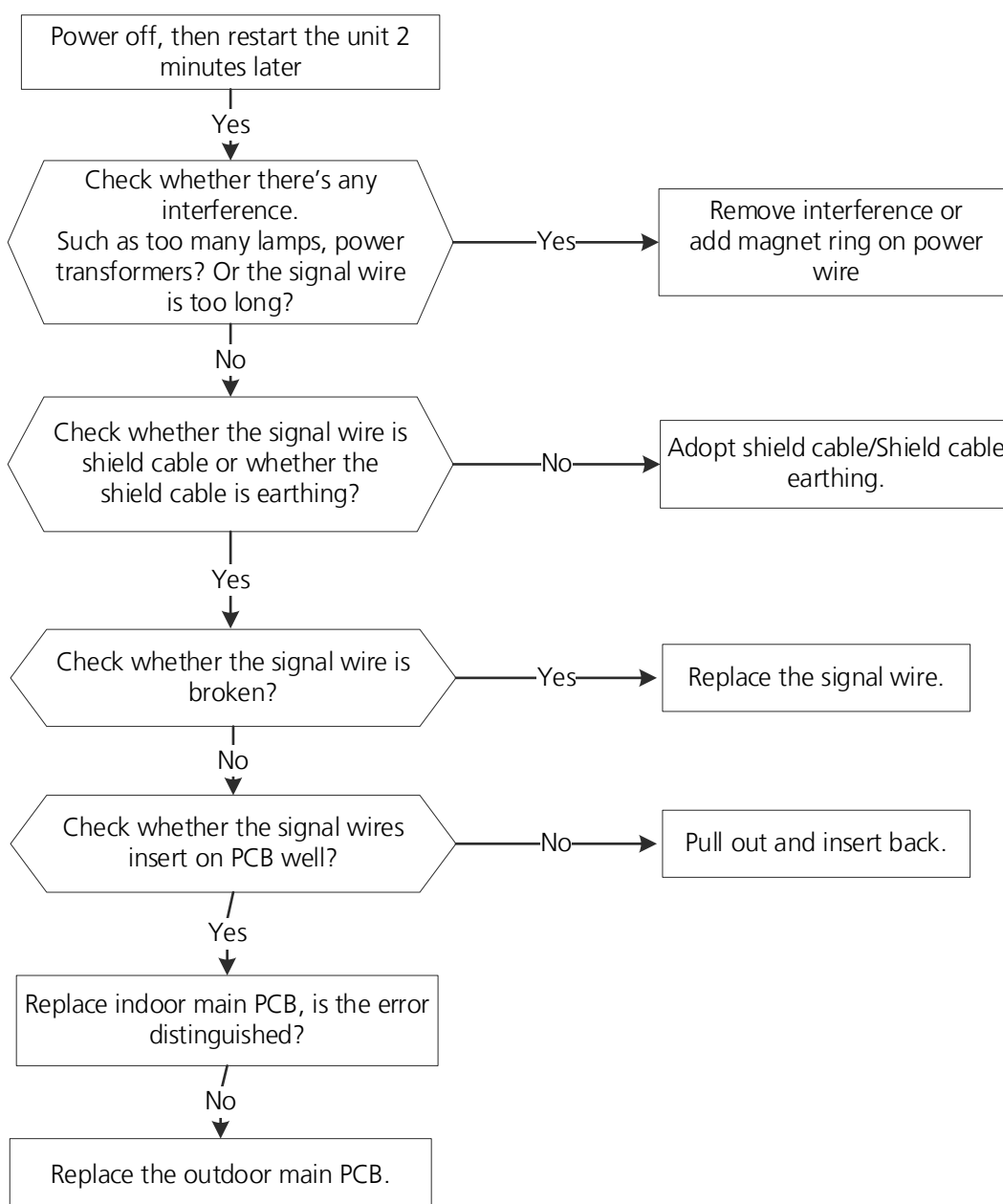

7.3 EH 03 / EC 07 (Fan Speed Is Operating Outside of Normal Range)/EC 71(Over Current Failure of Outdoor DC Fan Motor)/ EC73(Zero-speed failure of outdoor DC fan motor) Diagnosis and Solution

Description: When indoor / outdoor fan speed keeps too low or too high for a certain time, the unit ceases operation and the LED displays the failure.

Recommended parts to prepare:

- Connection wires
- Fan assembly
- Fan motor
- PCB

Troubleshooting and repair:

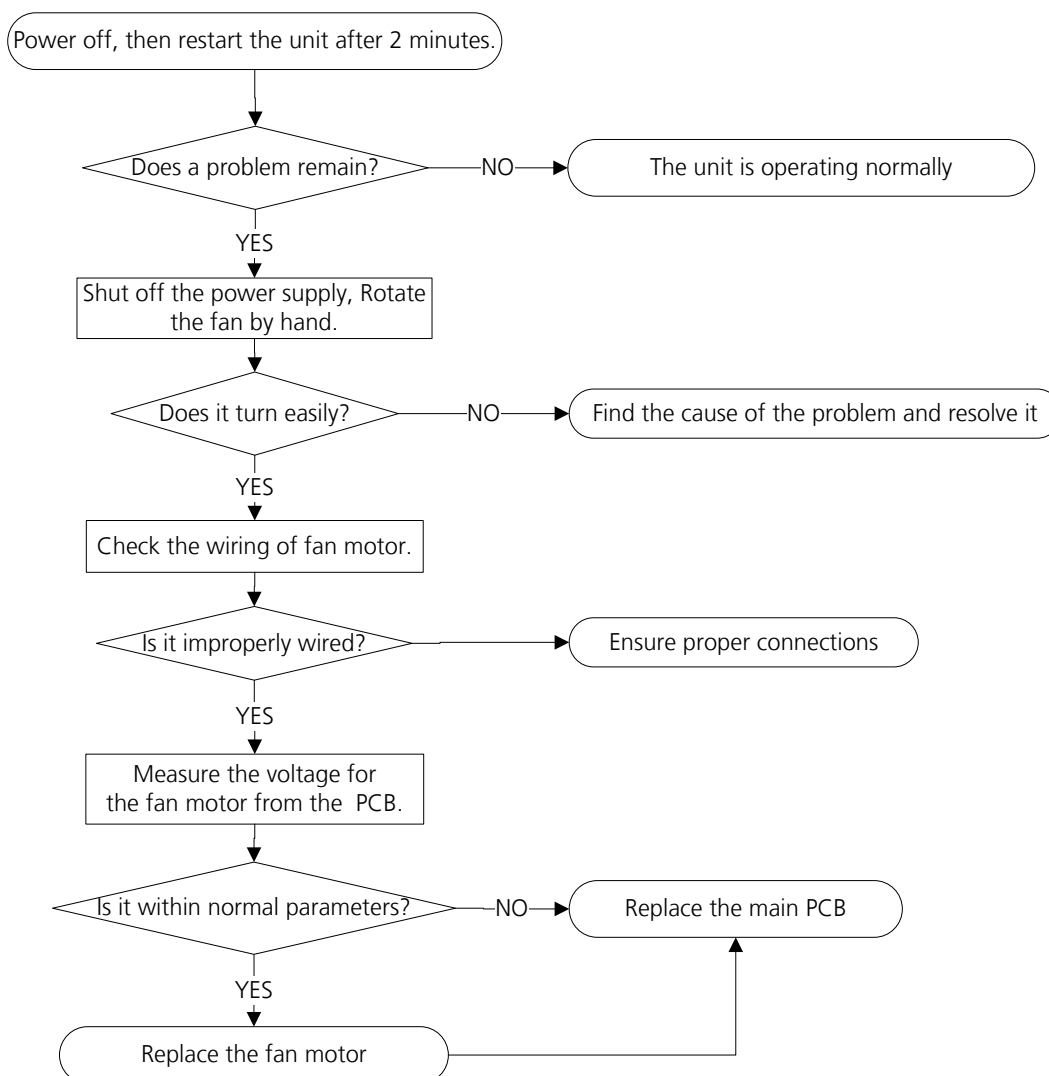

Index:**1. Indoor DC Fan Motor(control chip is in fan motor)**

Power on and when the unit is in standby, measure the voltage of pin1&pin2 of CN15, pin3 of CN34 in fan motor connector. If the value of the voltage is not in the range showing in below table, the PCB must has problems and need to be replaced.

**CN34**

NO.	Color	Signal	Voltage
1	/	/	
2	Black	GND	
3	Orange	PWM	5-12VDC
4	Blue	FG	0-12VDC

CN15

NO.	Color	Signal	Voltage
1	Yellow		208/230VAC
2	Black		208/230VAC
3	Yellow-Green	GND	

2. Outdoor DC Fan Motor (control chip is in outdoor PCB)

Release the UVW connector. Measure the resistance of U-V, U-W, V-W. If the resistance is not equal to each other, the fan motor must has problems and need to be replaced. otherwise the PCB must has problems and need to be replaced.



7.4 EH 60/EH 61/EH 62/ EH 65/ EC 53/EC 52/EC 54/EC 56/EC 57/EC 50/EC 5C (Open Circuit or Short Circuit of Temperature Sensor Diagnosis and Solution)

Description: If the sampling voltage is lower than 0.06V or higher than 4.94V, the LED displays the failure.

Recommended parts to prepare:

- Connection wires
- Sensors
- PCB

Troubleshooting and repair:

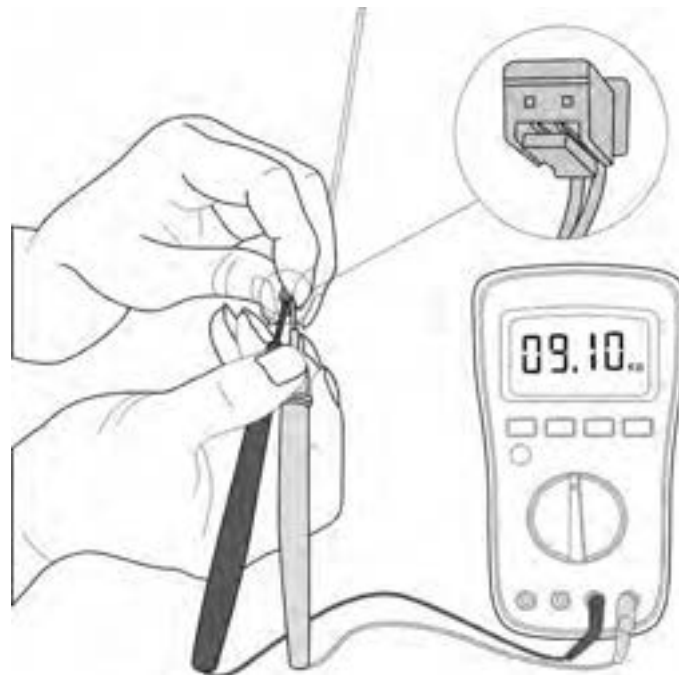
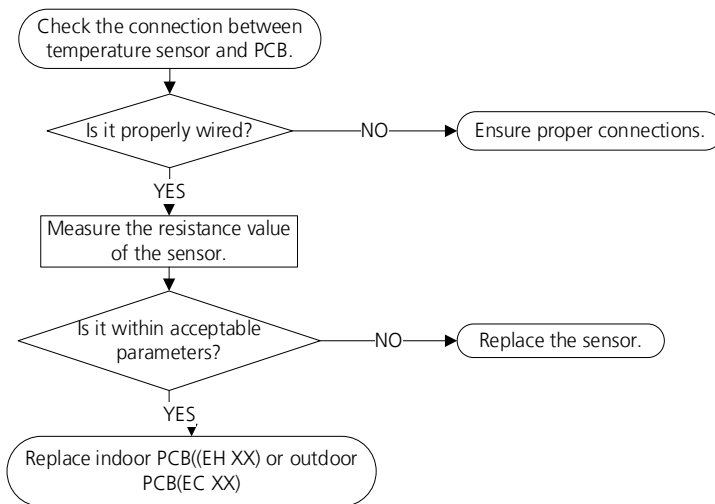

This picture and the value are only for reference, actual appearance and value may vary

7.5 EL 0C (Refrigerant Leakage Detection Diagnosis and Solution)

Description:

Judging the abnormality of the refrigeration system according to the number of compressor stops and the changes in operating parameters caused by excessive exhaust temperature.

Recommended parts to prepare:

- Indoor PCB
- Additional refrigerant

Troubleshooting and repair:

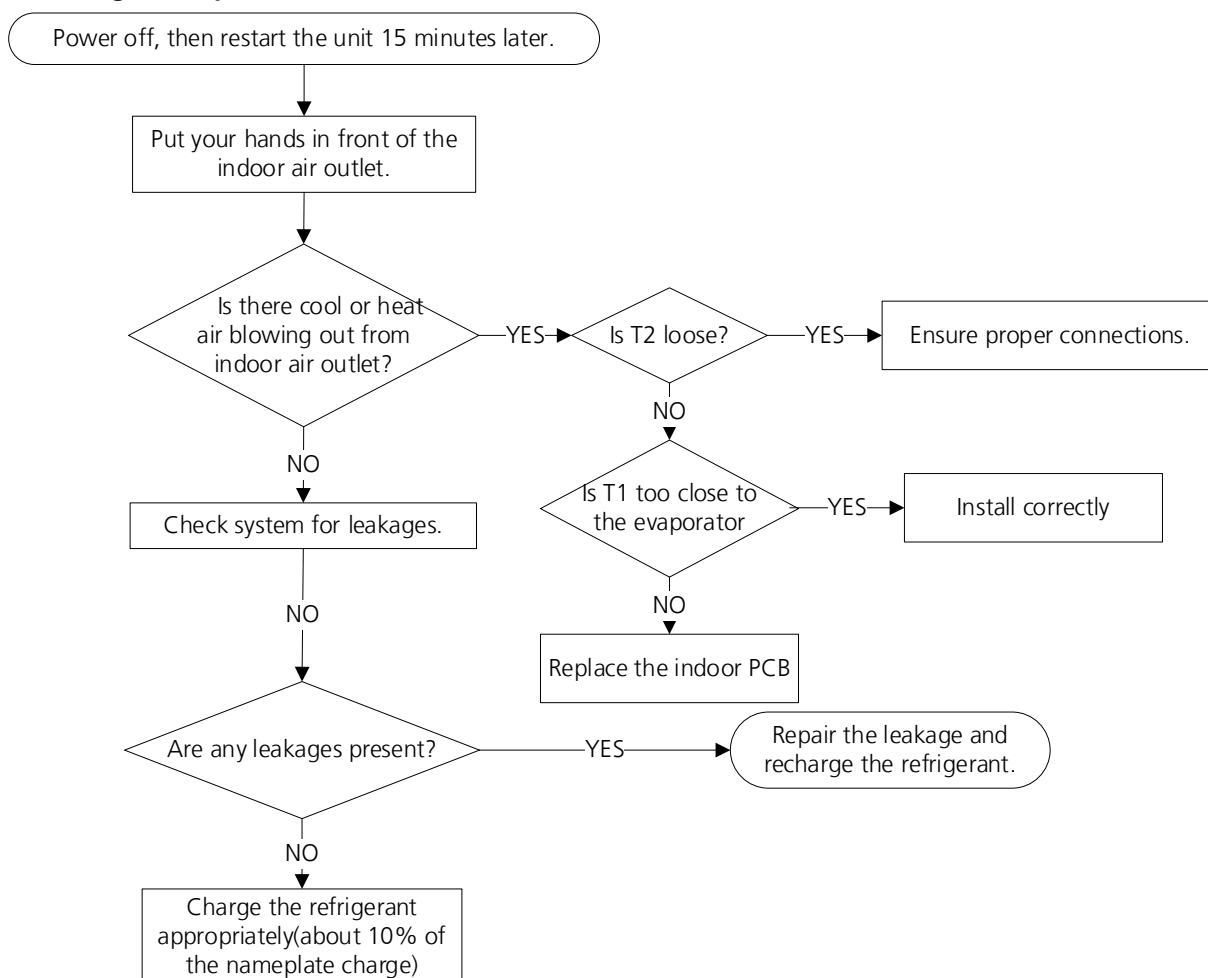

7.6 EH 0E(Water-Level Alarm Malfunction Diagnosis and Solution)

Description: If the sampling voltage is not 5V, the LED displays the failure code.

Recommended parts to prepare:

- Connection wires
- Water-level switch
- Indoor PCB

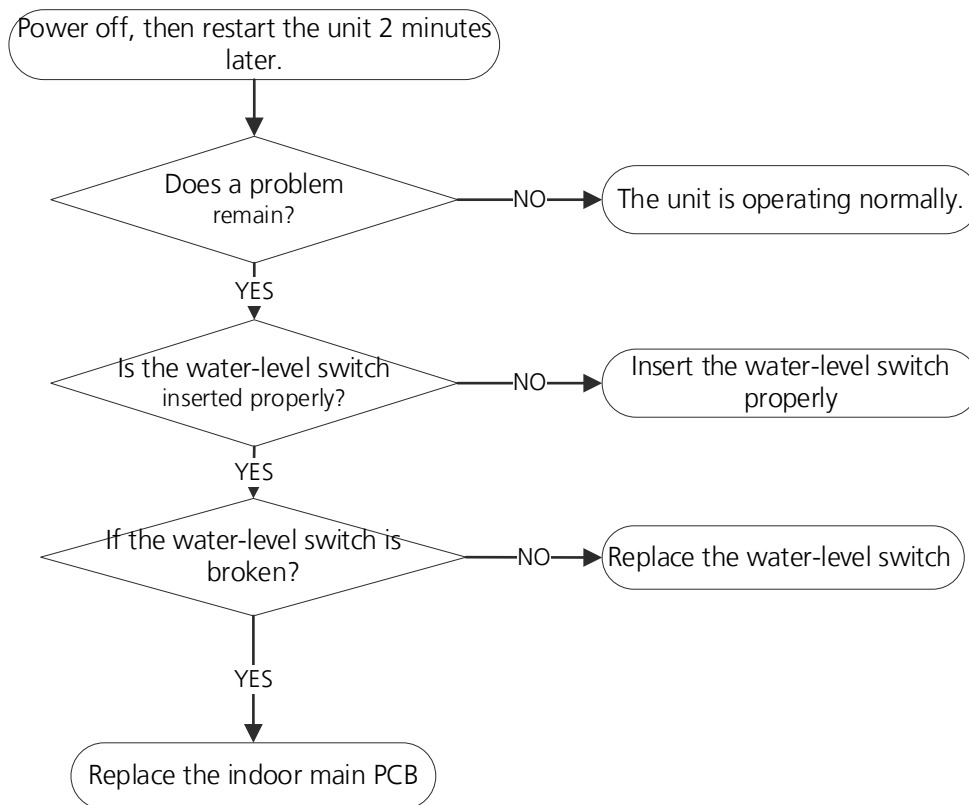

7.7 PC 00(IPM malfunction or IGBT over-strong current protection Diagnosis and Solution)

Description: When the voltage signal the IPM sends to the compressor drive chip is abnormal, the display LED shows “PC 00” and the AC turn off.

Recommended parts to prepare:

- Connection wires
- IPM module board
- Outdoor fan assembly
- Compressor
- Outdoor PCB

Troubleshooting and repair:

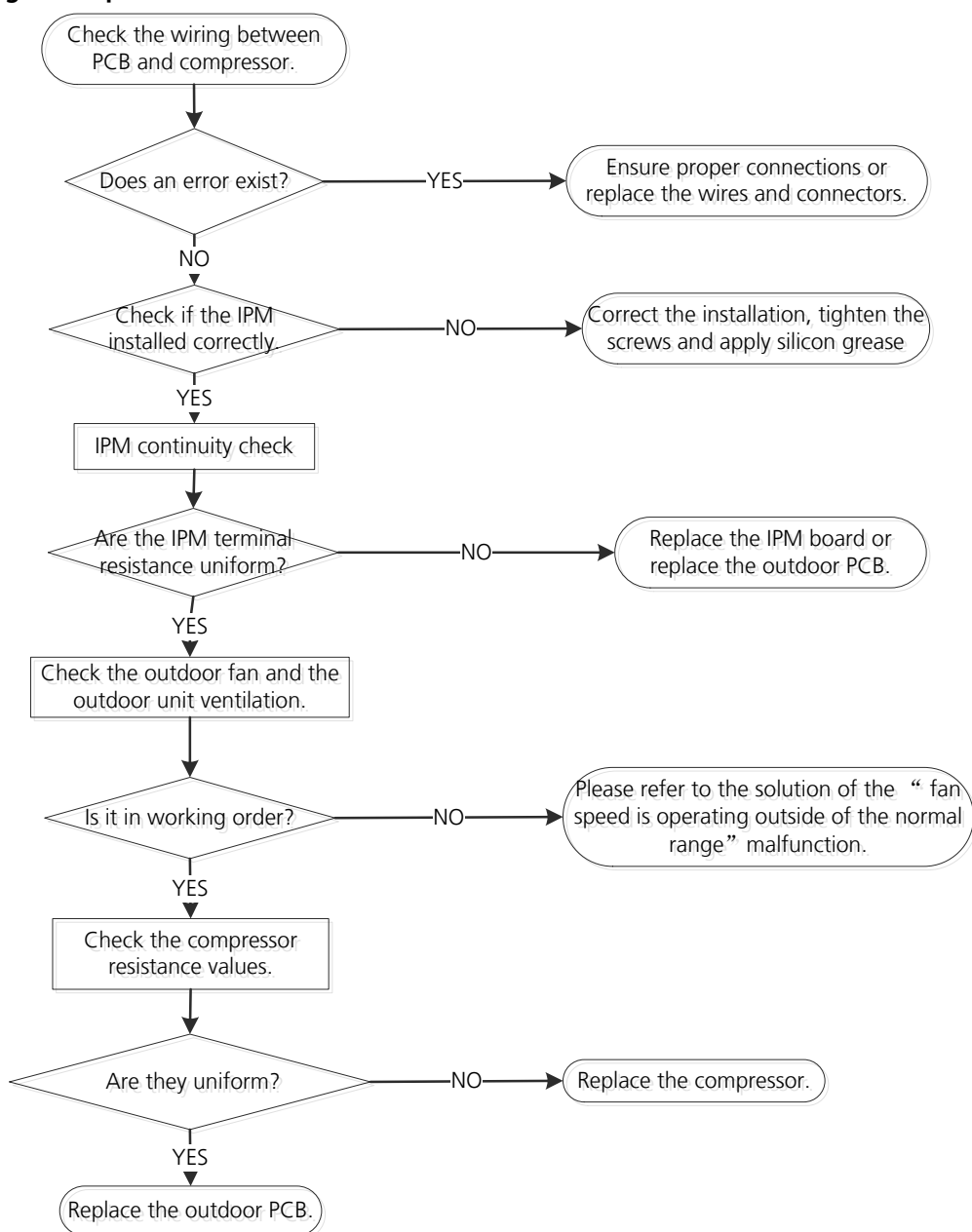

7.8 PC 01(Over voltage or too low voltage protection)/PC 10(Outdoor unit low AC voltage protection)/PC 11(Outdoor unit main control board DC bus high voltage protection)/PC 12(Outdoor unit main control board DC bus high voltage protection /341 MCE error) Diagnosis and Solution

Description: Abnormal increases or decreases in voltage are detected by checking the specified voltage detection circuit.

Recommended parts to prepare:

- Power supply wires
- IPM module board
- PCB
- Reactor

Troubleshooting and repair:

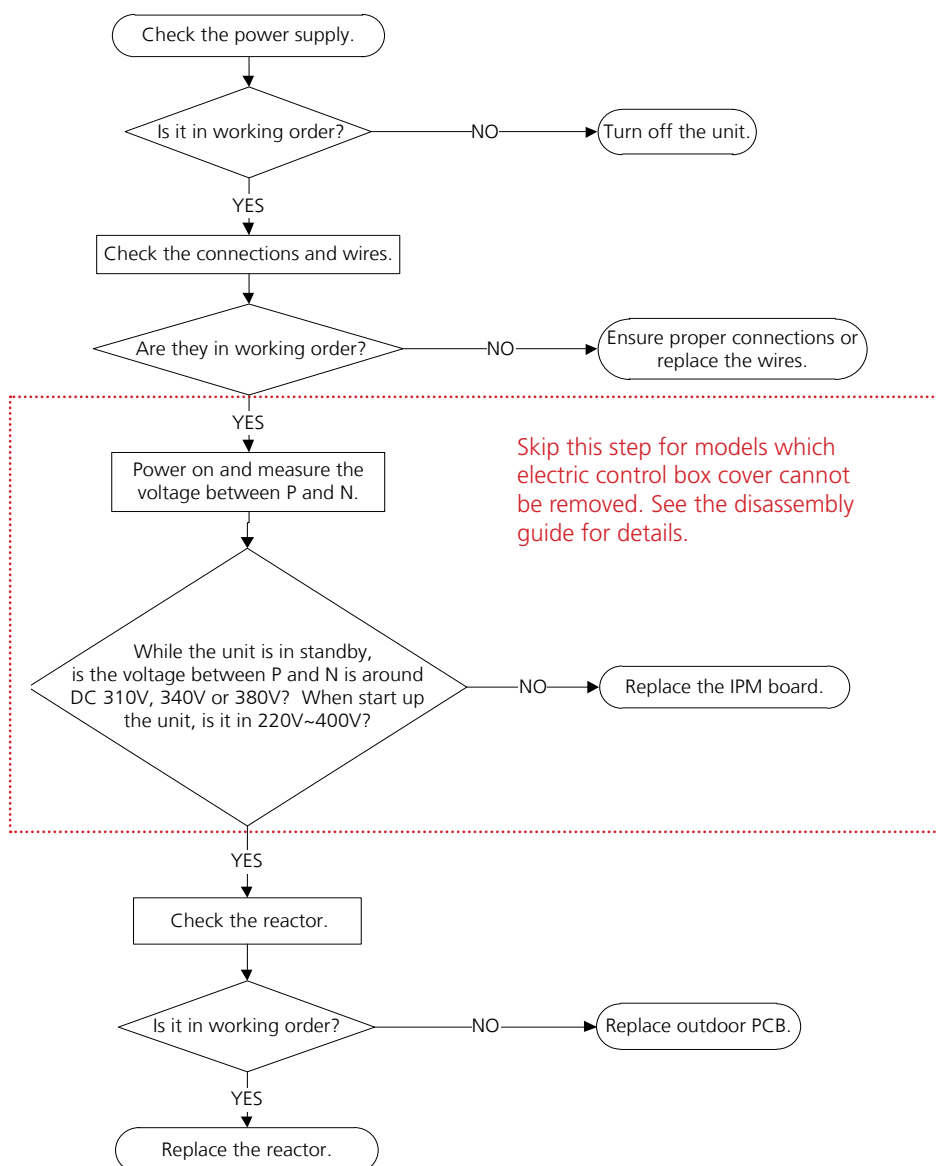

7.9 PC 04(Inverter compressor drive error Diagnosis and Solution)

Description: An abnormal inverter compressor drive is detected by a special detection circuit, including communication signal detection, voltage detection, compressor rotation speed signal detection and so on.

Recommended parts to prepare:

- Connection wires
- IPM module board
- Outdoor fan assembly
- Compressor
- Outdoor PCB

Troubleshooting and repair:

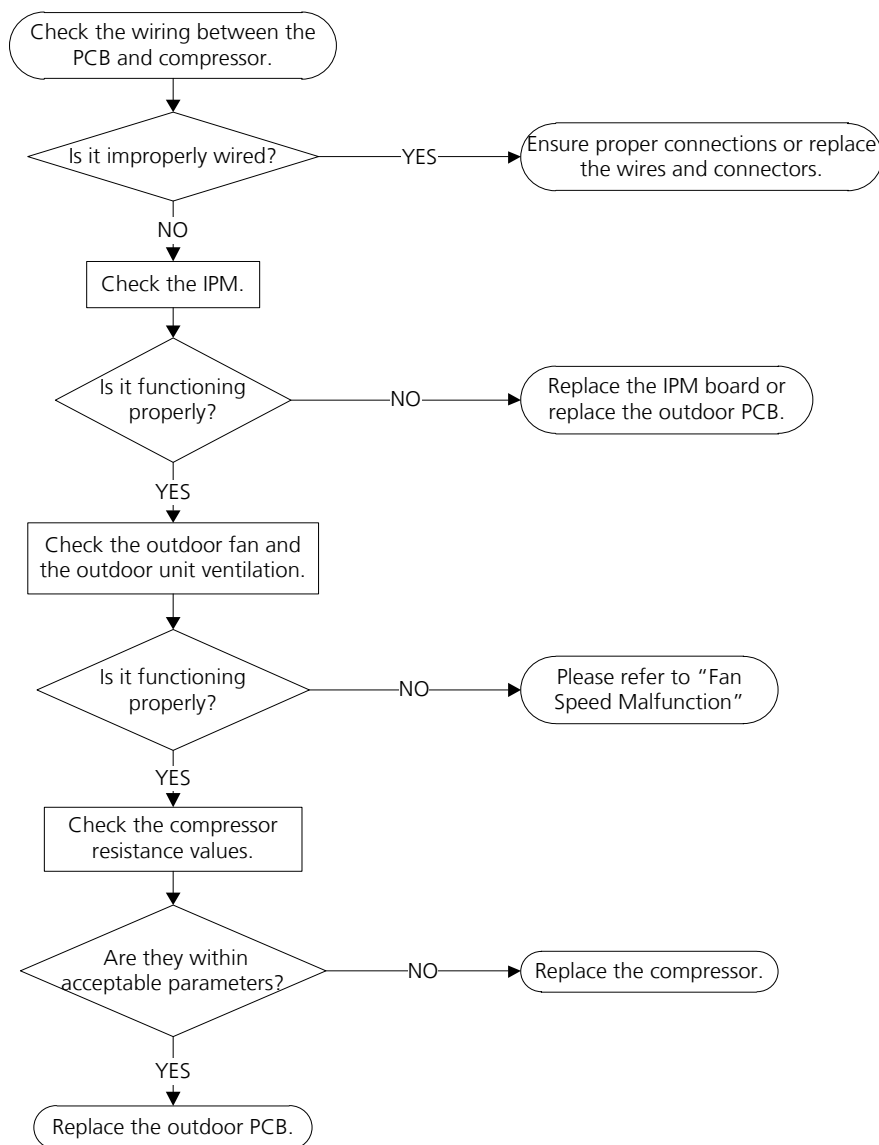

7.10 PC 03/PC 31(Low Pressure Protection Diagnosis and Solution)

Description: If the sampling voltage is not 5V, the LED displays a failure code.

Recommended parts to prepare:

- Connection wires
- Low pressure protector
- Indoor fan assembly
- Outdoor PCB

Troubleshooting and repair:

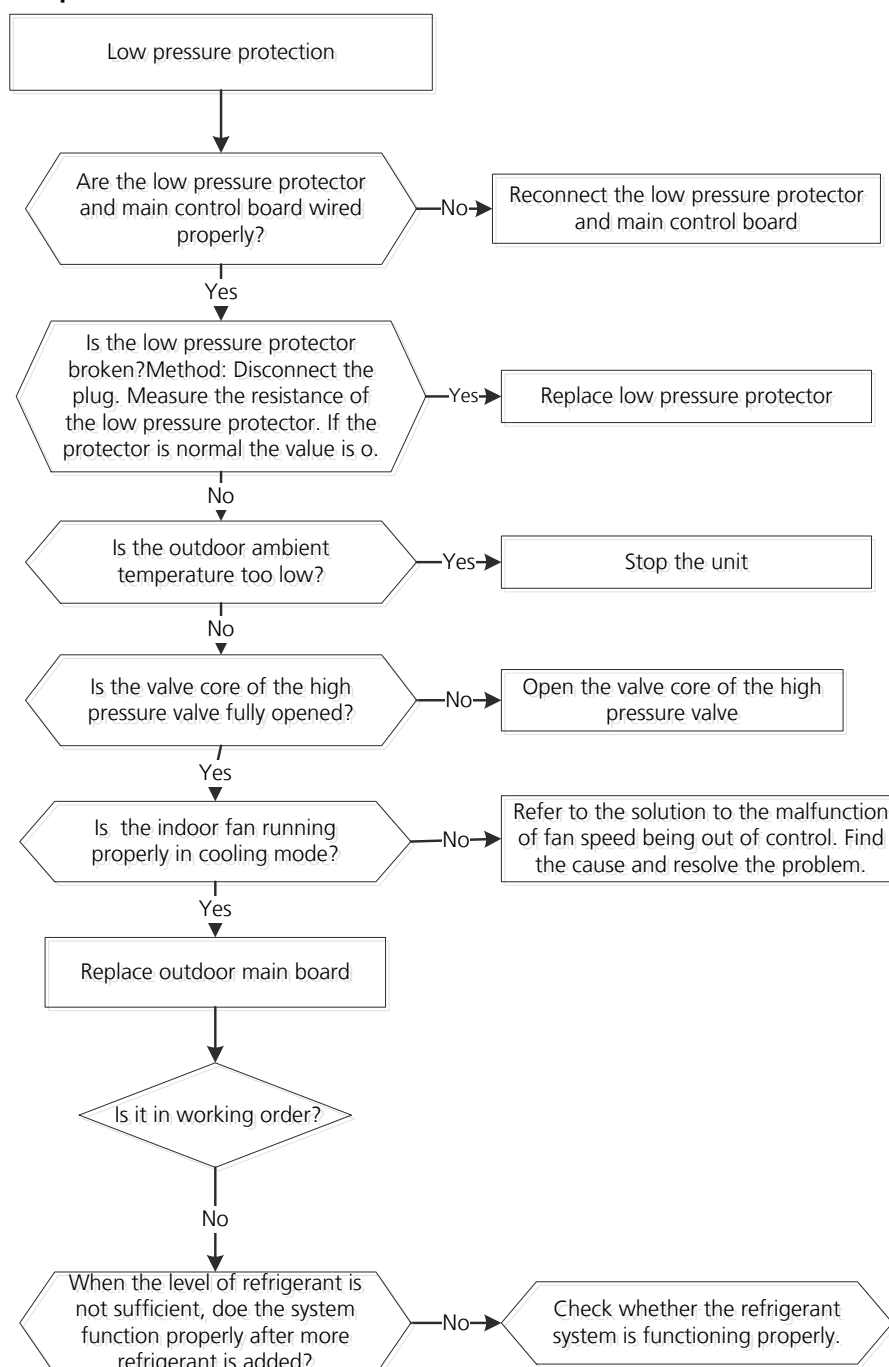

7.11 PC 02/LC 06(Top temperature protection of compressor or High temperature protection of IPM module diagnosis and solution)

Description: For some models with overload protector, If the sampling voltage is not 5V, the LED will display the failure. If the temperature of IPM module is higher than a certain value, the LED displays the failure code.

Models without overload protector should be diagnosed according to the second flowchart.

Recommended parts to prepare:

- Connection wires
- Outdoor PCB
- IPM module board
- High pressure protector
- System blockages

Troubleshooting and repair:

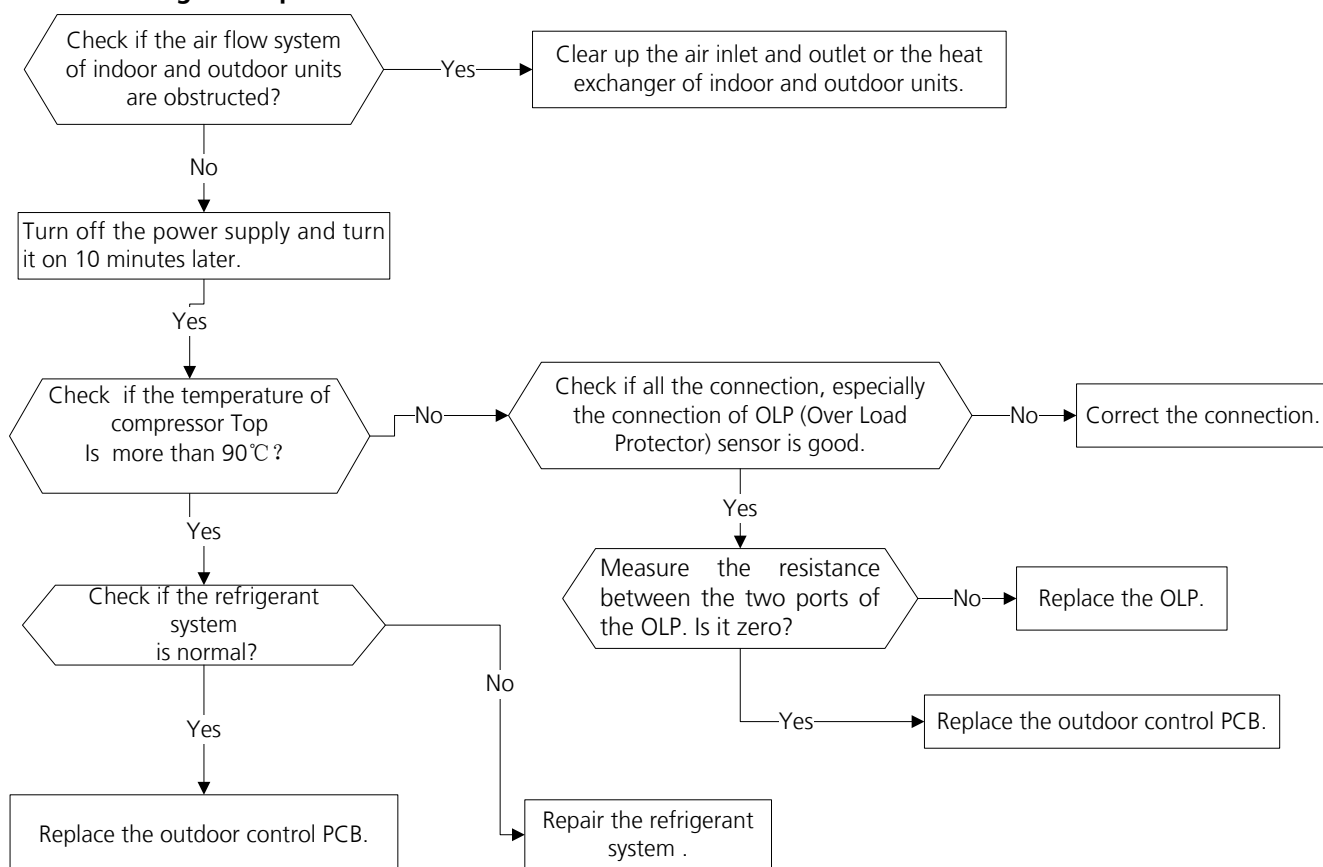

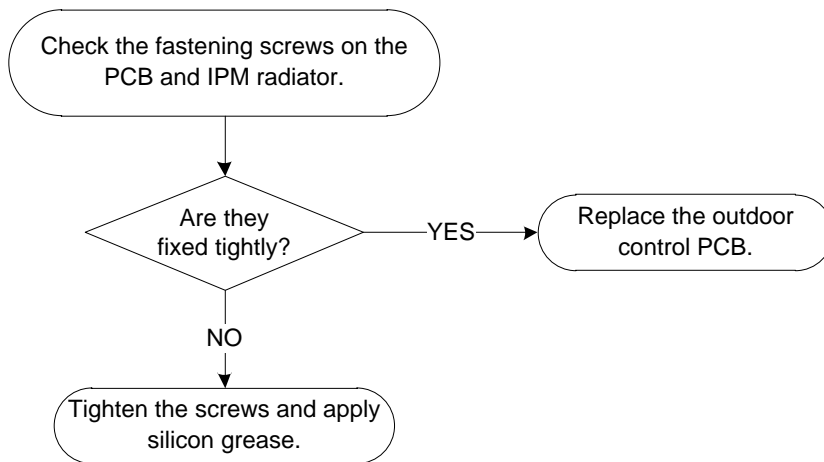

7.12 EC 0d(Outdoor unit malfunction Diagnosis and Solution)

Description: The indoor unit detect the outdoor unit is error.

Recommended parts to prepare:

- Outdoor unit

Troubleshooting and repair:

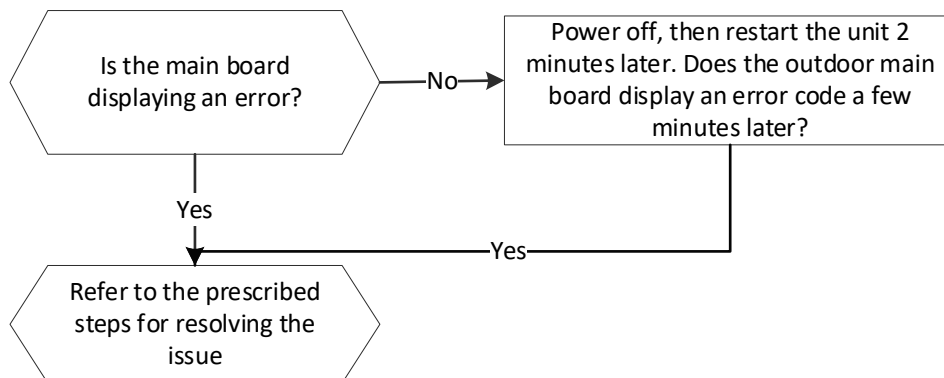

7.13 PC 40(Communication error between outdoor main PCB and IPM board diagnosis and solution)

Description: The main PCB cannot detect the IPM board.

Recommended parts to prepare:

- Connection wires
- IPM board
- Outdoor main PCB
- Electric control box

Troubleshooting and repair:

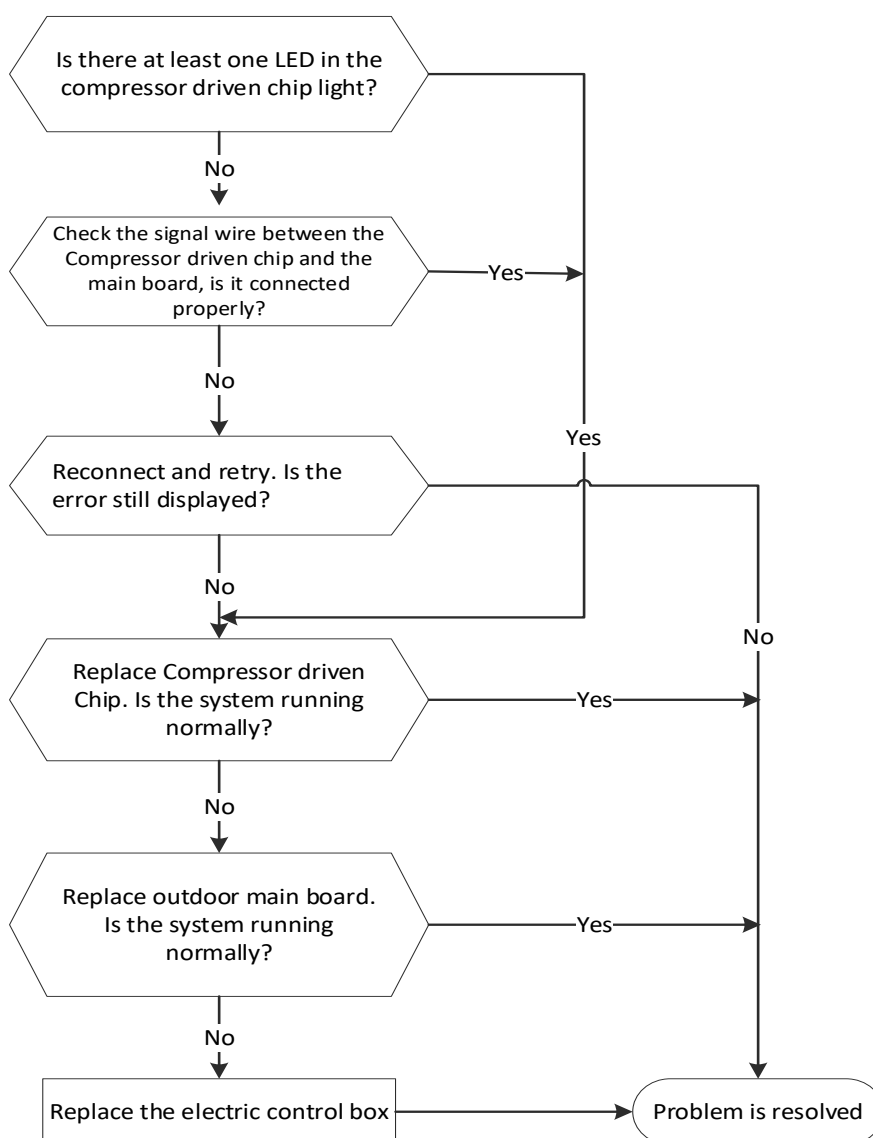

7.14 PC 08(Current overload protection)/PC 44(Outdoor unit zero speed protection)/ PC 46(Compressor speed has been out of control)/PC 49(Compressor overcurrent failure) diagnosis and solution

Description: An abnormal current rise is detected by checking the specified current detection circuit.

Recommended parts to prepare:

- Connection wires
- Rectifier
- PFC circuit or reactor
- Blocked refrigeration piping system
- Pressure switch
- Outdoor fan
- IPM module board
- Outdoor PCB

Troubleshooting and repair:

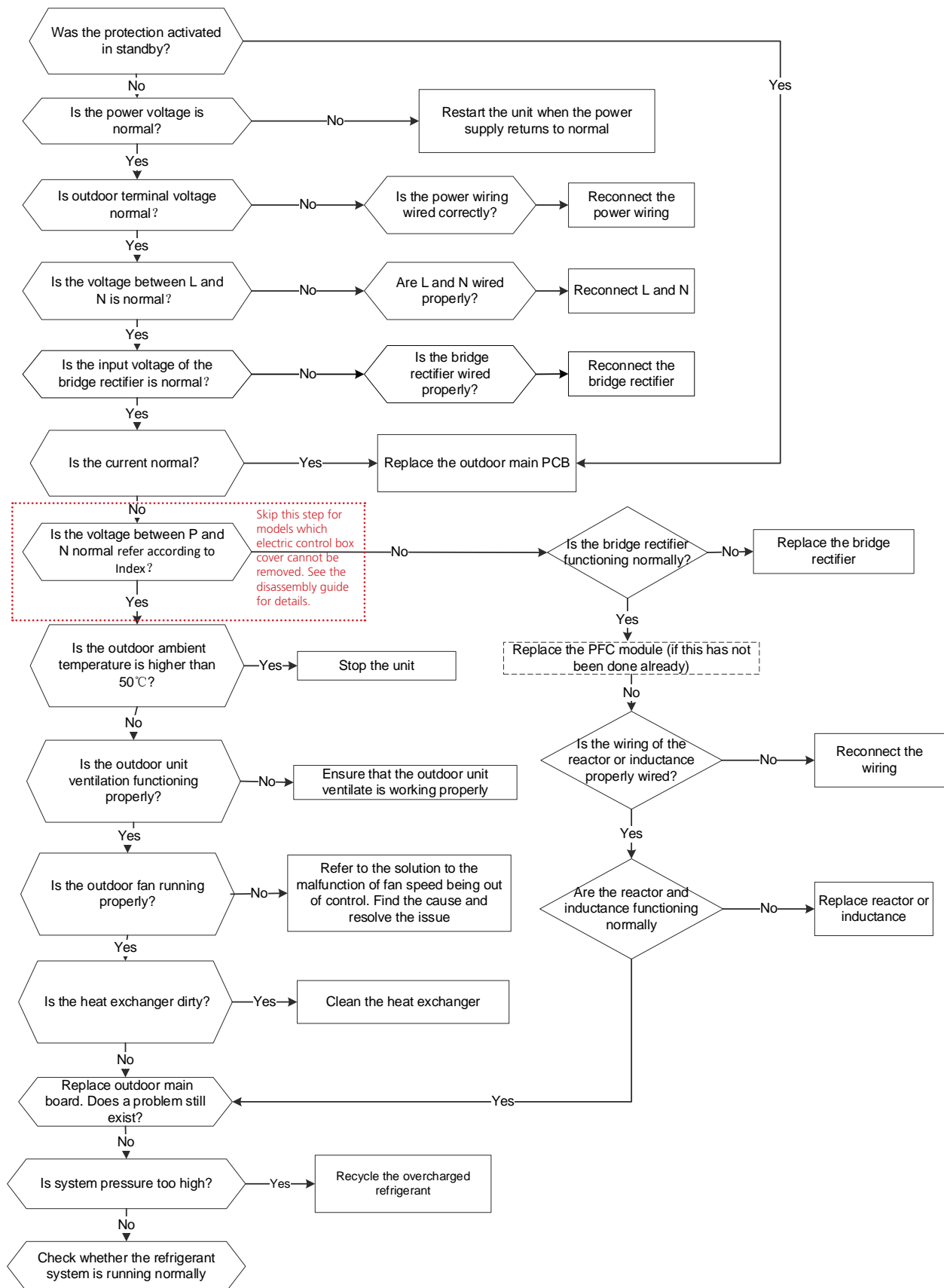

7.15 PC OF(PFC module protection diagnosis and solution)

Description: When the voltage signal that IPM send to compressor drive chip is abnormal, the LED displays the failure code and the AC turns off.

Recommended parts to prepare:

- Connection wires
- Inductance
- Outdoor main PCB
- PFC module

Troubleshooting and repair:

At first test the resistance between every two ports of U, V, W of IPM and P, N. If any result of them is 0 or close to 0, the IPM is defective. Otherwise, please follow the procedure below:

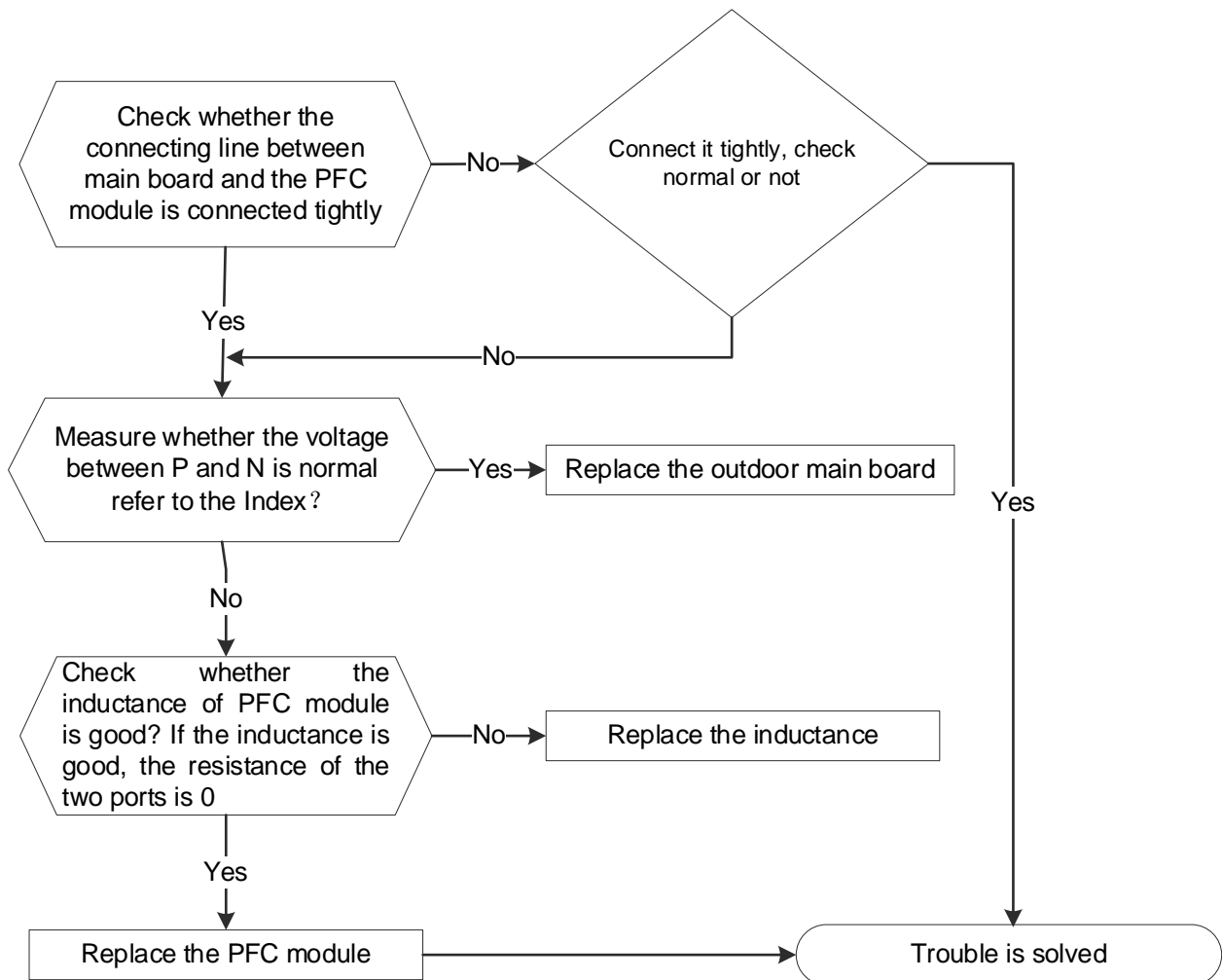

7.16 EC 72 (Lack phase failure of outdoor DC fan motor diagnosis and solution)

Description: When the three-phase sampling current of the DC motor is abnormal, especially when the current of one or more phases is always small and almost 0, the LED displays the failure code.

Recommended parts to prepare:

- Connection wire
- Fan motor
- Outdoor PCB

Troubleshooting and repair:

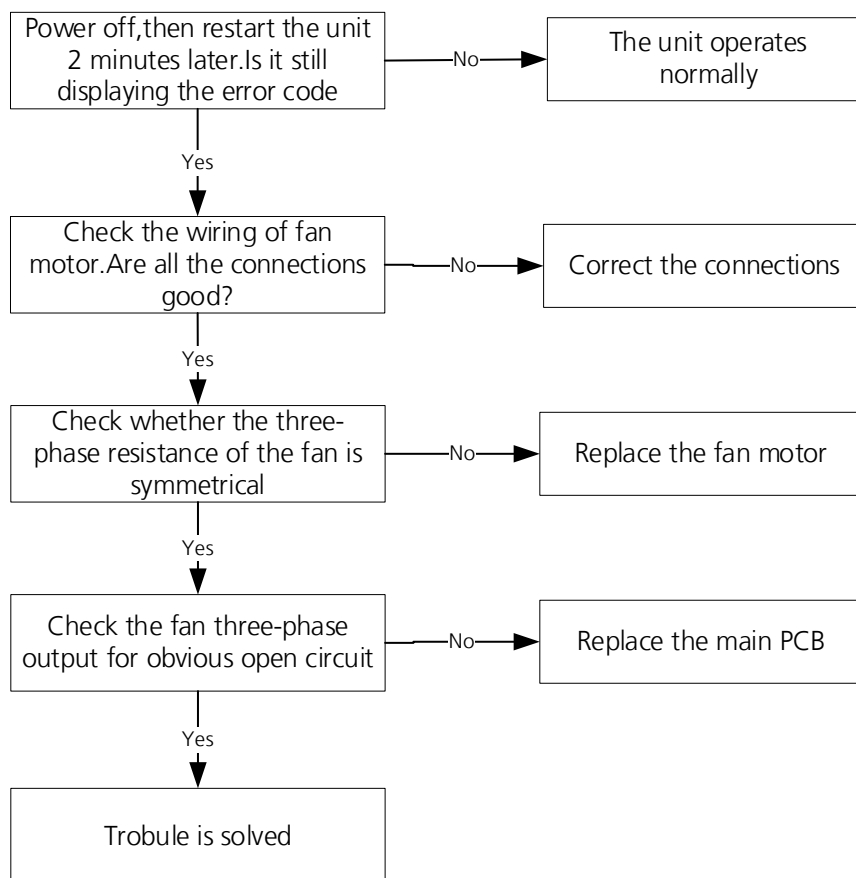

7.17 PC 43 (Outdoor compressor lack phase protection diagnosis and solution)

Description: When the three-phase sampling current of the compressor is abnormal, especially when the current of one or more phases is always small and almost 0, the LED displays the failure code

Recommended parts to prepare:

- Connection wire
- Compressor
- Outdoor PCB

Troubleshooting and repair:

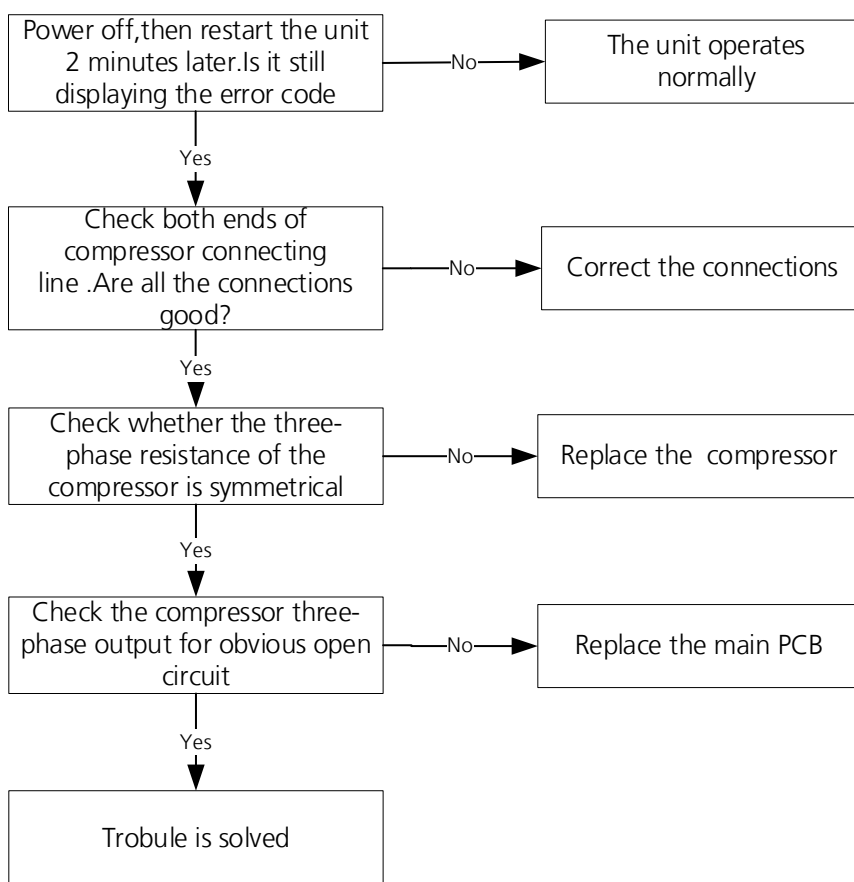

7.18 PC 45 (Outdoor unit IR chip drive failure) diagnosis and solution

Description: When the IR chip detects its own parameter error, the LED displays the failure code when power on.

Recommended parts to prepare:

- Inverter module PCB.

Troubleshooting and repair:

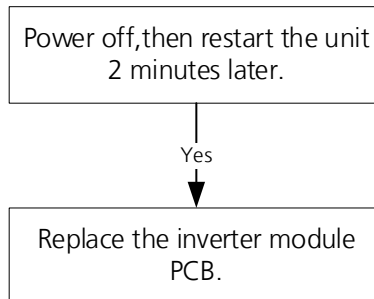

7.19 PC 0L (Low ambient temperature protection)

Description: It is a protection function. When compressor is off, outdoor ambient temperature(T4) is lower than -35°C. for 10s, the AC will stop and display the failure code.

When compressor is on, outdoor ambient temperature(T4) is lower than -40°C. for 10s, the AC will stop and display the failure code.

When outdoor ambient temperature(T4) is no lower than -32°C. for 10s, the unit will exit protection.

7.20 EC55 (Outdoor IPM module temperature sensor fault) diagnosis and solution

Description: If the sampling voltage is 0V or 5V, the LED displays the failure code.

Recommended parts to prepare:

- IPM module PCB
- Connection wires
- Sensors
- Outdoor main PCB

Troubleshooting and repair:

If the radiator has no sensor, follow the steps below to resolve,

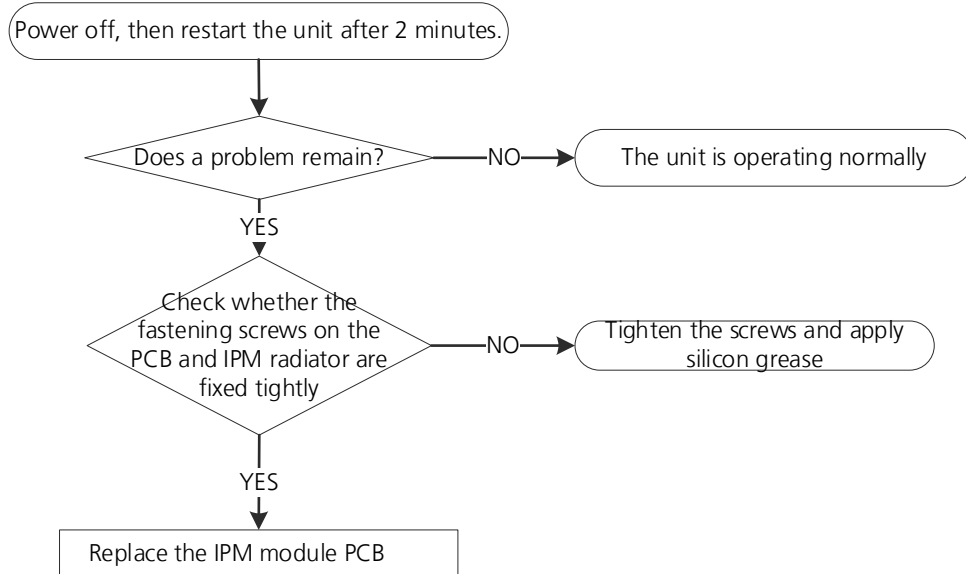

If the radiator has a sensor(TH), follow the steps below to resolve,

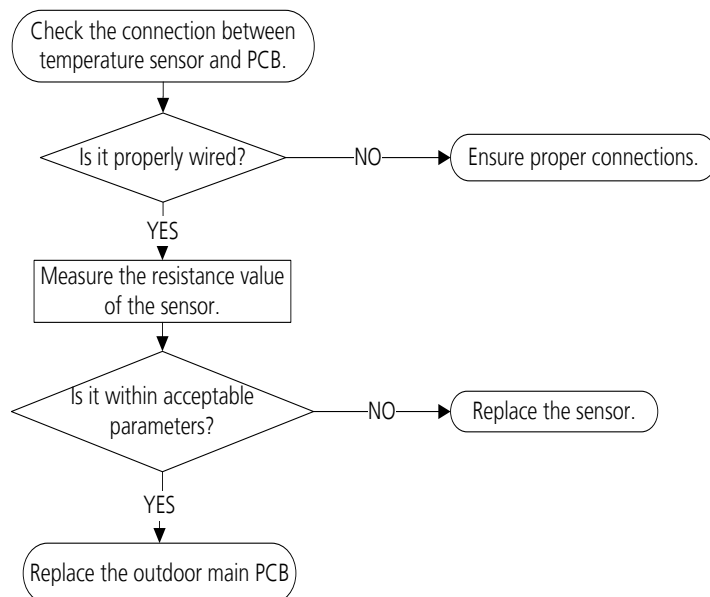

7.21 PC 03/PC 30 (High pressure protection diagnosis and solution)

Description: Outdoor pressure switch cut off the system because high pressure is higher than 4.4 MPa

Recommended parts to prepare:

- Connection wires
- Pressure switch
- Outdoor fan
- Outdoor main PCB

Troubleshooting and repair:

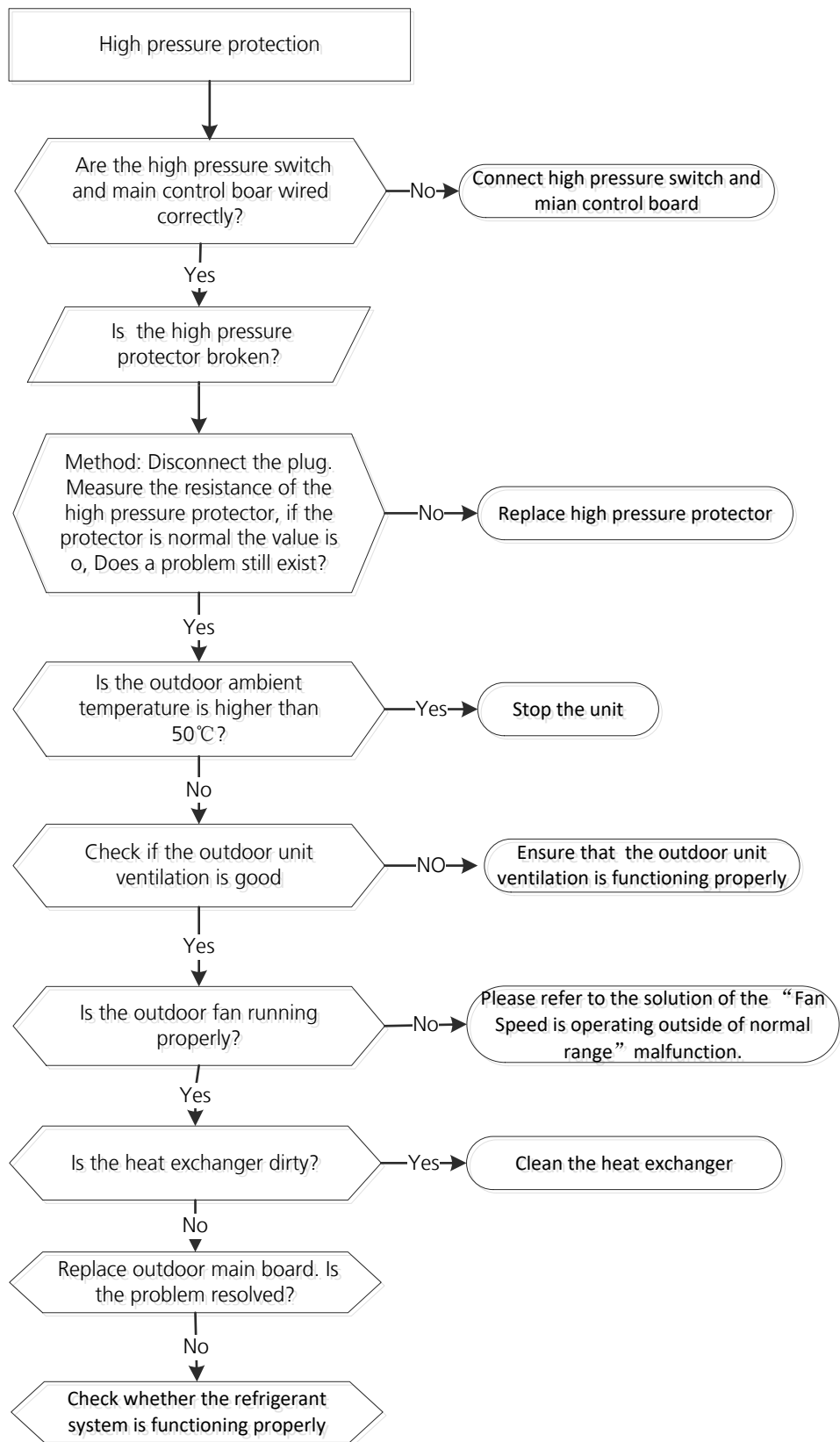

7.22 PC 0A (High temperature protection of condenser diagnosis and solution)

Description: When the outdoor pipe temperature is more than 65°C, the unit stops. It starts again only when the outdoor pipe temperature is less than 52°C.

Recommended parts to prepare:

- Connection wires
- Condenser temperature sensor
- Outdoor fan
- Outdoor main PCB
- Refrigerant

Troubleshooting and repair:

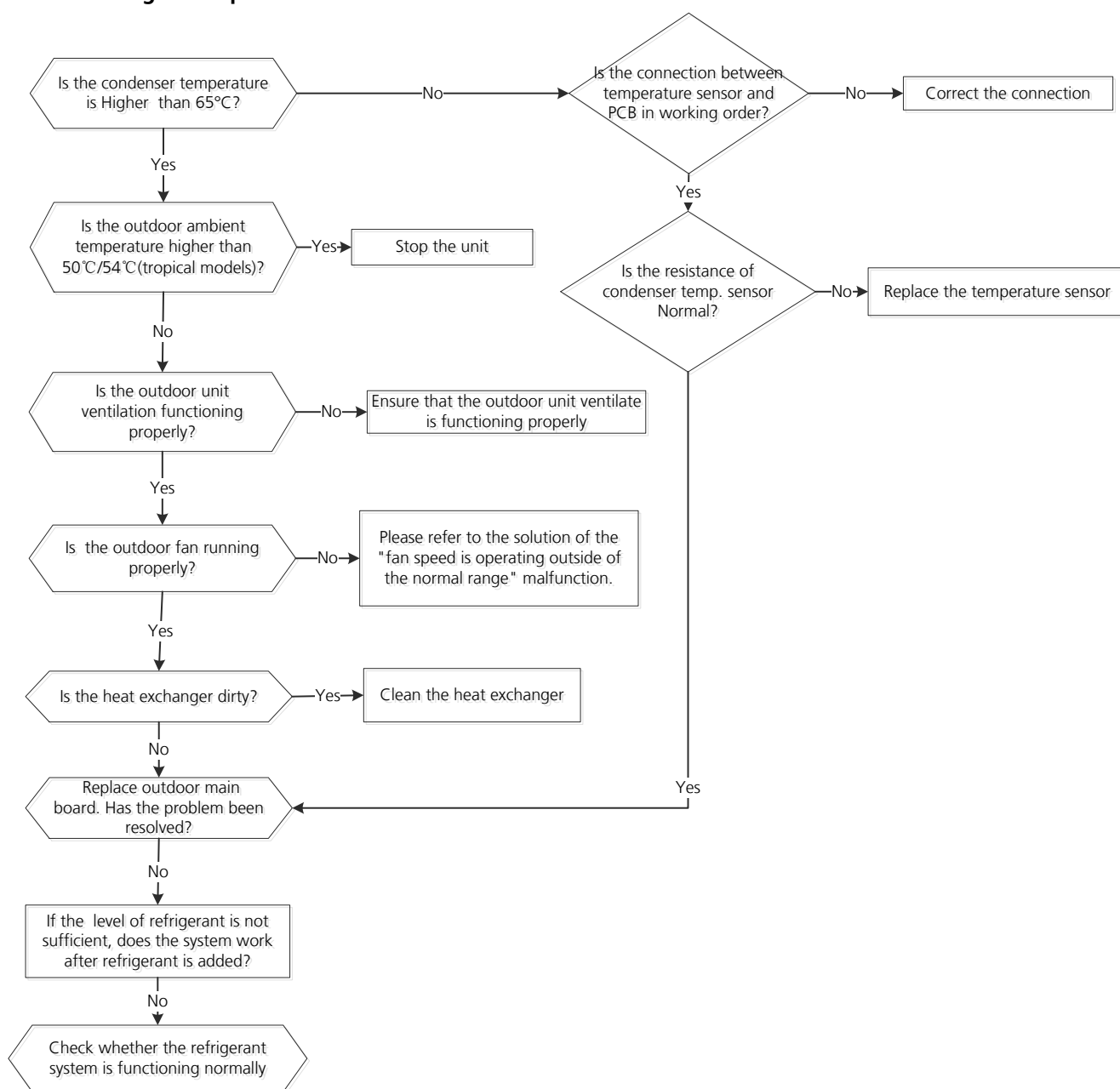

7.23 PC 06 (Discharge temperature protection of compressor diagnosis and solution)

Description: If the compressor discharge temperature exceeds a certain level for nine seconds, the compressor ceases operation, the LED displays the failure code

Recommended parts to prepare:

- Connection wires
- Discharge temperature sensor
- Additional refrigerant
- Outdoor main PCB

Troubleshooting and repair:

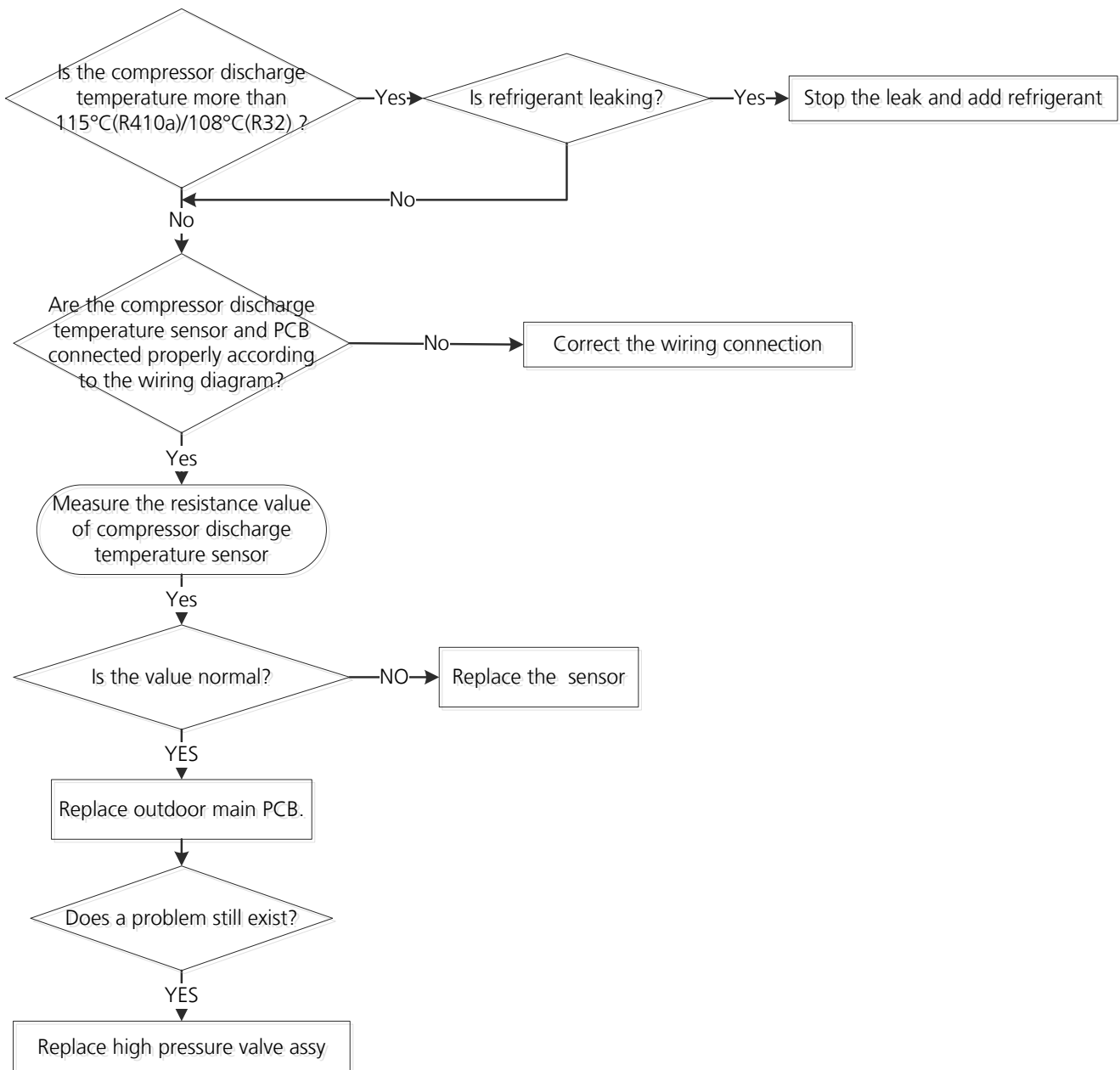

Note: For certain models, outdoor unit uses combination sensor, T3,T4 and TP are the same of sensor. This picture and the value are only for reference, actual appearance and value may vary.

7.24 EH 0b(Communication error between indoor two chips diagnosis and solution)

Description: Indoor PCB main chip does not receive feedback from another chip.

Recommended parts to prepare:

- Indoor main board
- Adapter board

Troubleshooting and repair:

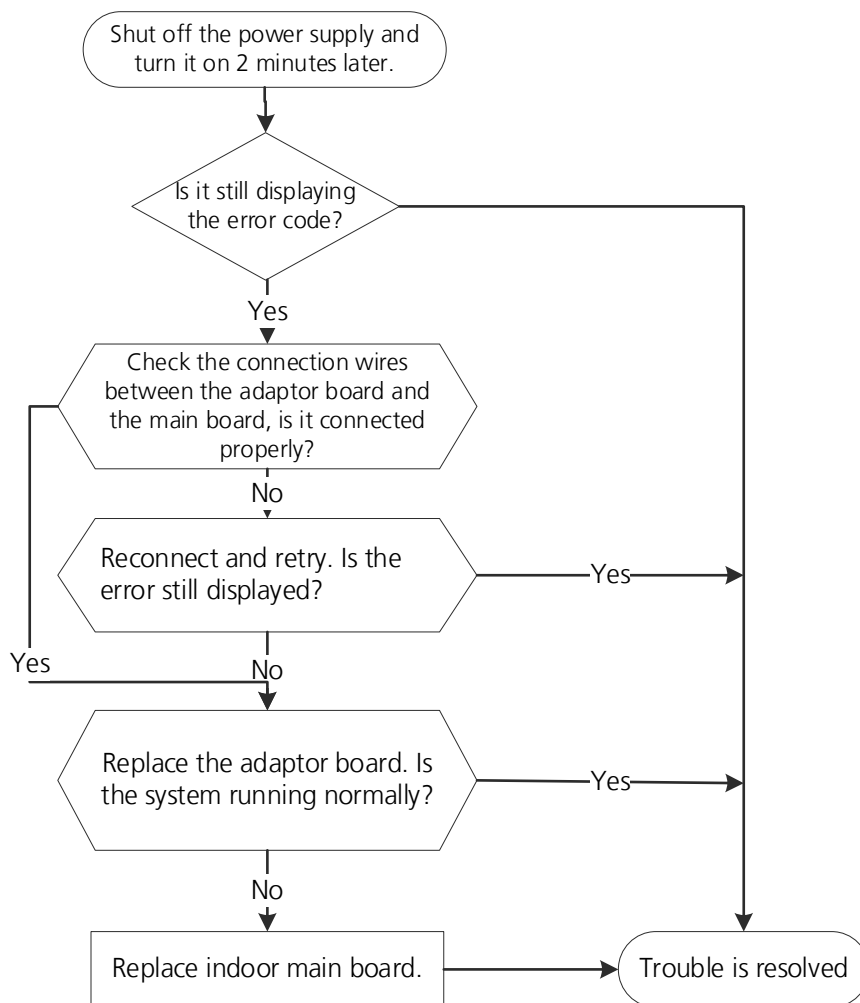

7.25 EL 16(Communication malfunction between adapter board and outdoor main board diagnosis and solution)

Description: The adapter PCB cannot detect the main control board.

Recommended parts to prepare:

- Connection wires
- Adapter board
- Outdoor main PCB

Troubleshooting and repair:

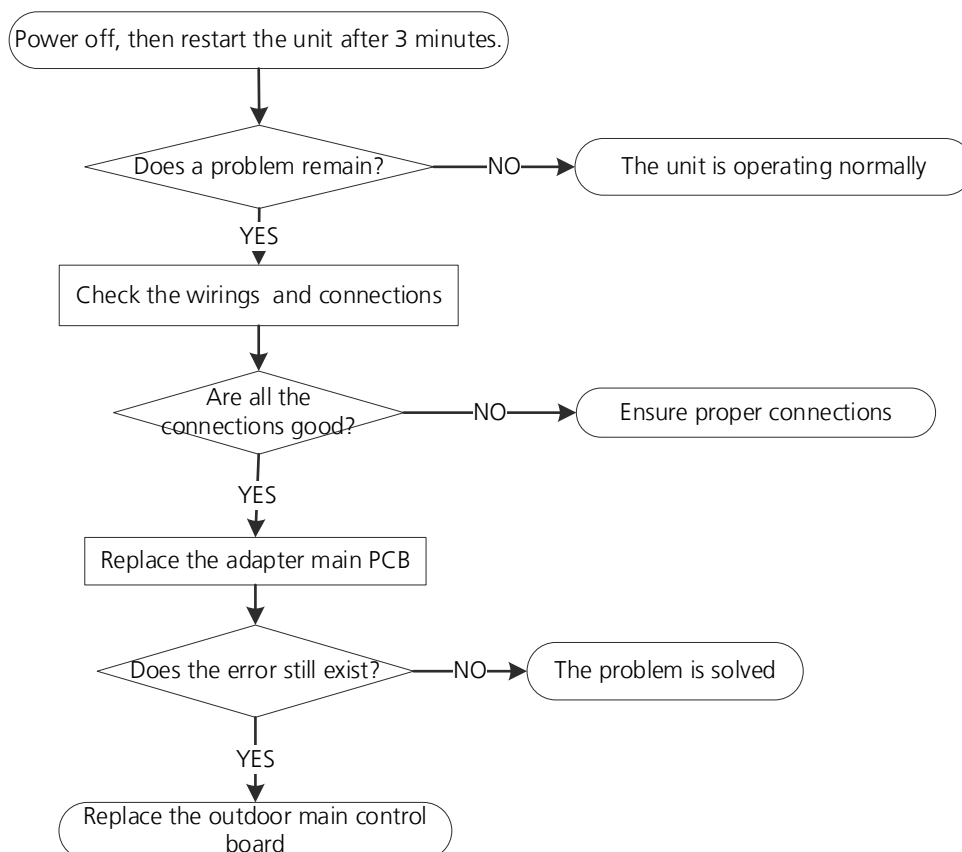

7.26 FL 09 (Indoor and outdoor mismatch malfunction diagnosis and solution)

Description: Indoor and outdoor units are mismatched, the LED displays this code. Please replace the matching indoor or outdoor unit.

7.27 PC 41(Outdoor compressor current sampling circuit failure diagnosis and solution)

Description: Three-phase sampling offset voltage error, the static bias voltage is normally 2.5V

Recommended parts to prepare:

- Outdoor main PCB

Troubleshooting and repair:

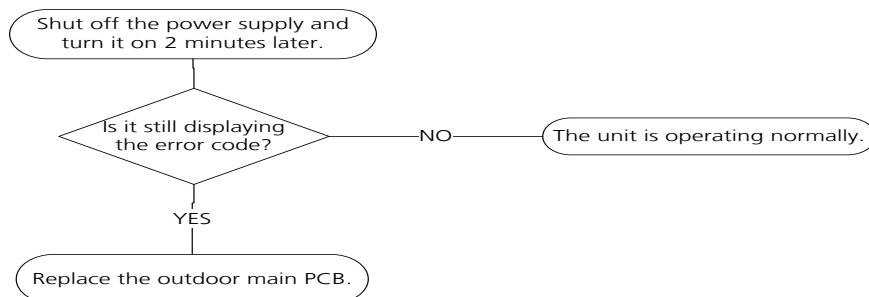

7.28 EH b3 (Communication error between wired controller and indoor unit Diagnosis and Solution)

Description: If Indoor PCB does not receive feedback from wired controller, the error displays on the wired controller

Recommended parts to prepare:

- Connection wires
- Indoor PCB
- Wired controller

Troubleshooting and repair:

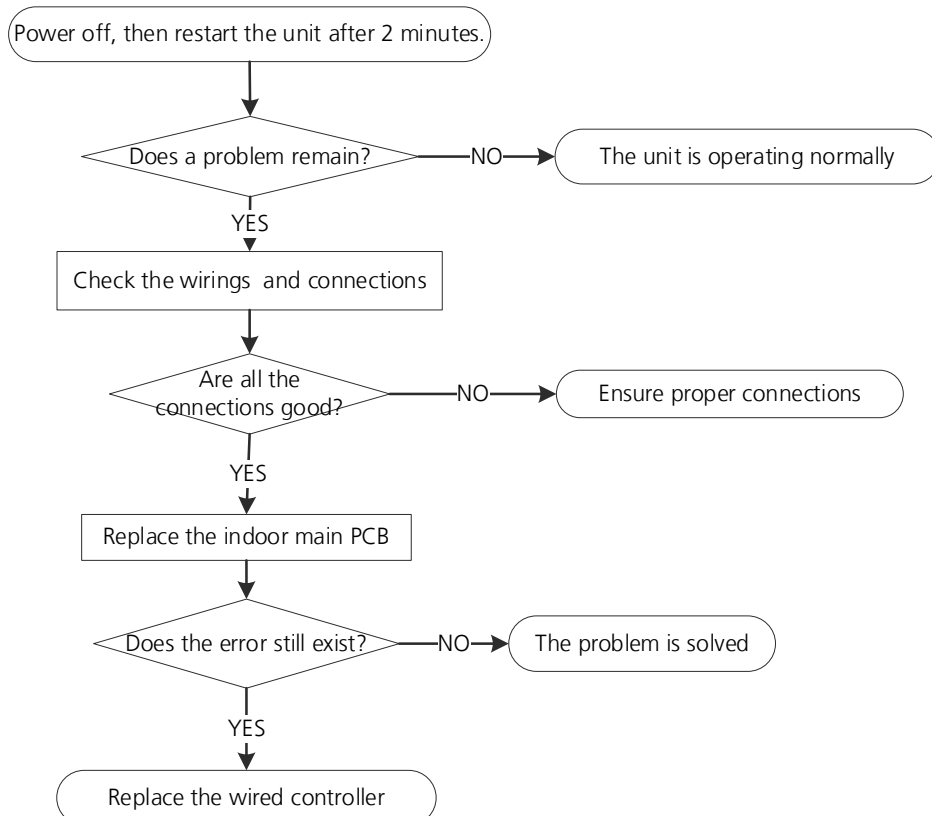

8. Check Procedures

8.1 Temperature Sensor Check

WARNING

Be sure to turn off all power supplies or disconnect all wires to avoid electric shock. Operate after compressor and coil have returned to normal temperature in case of injury.

1. Disconnect temperature sensor from PCB (Refer to Chapter 5. Indoor Disassembly and Chapter 6. Outdoor Disassembly).
2. Measure the resistance value of the sensor using a multi-meter.
3. Check corresponding temperature sensor resistance value table (Refer to Chapter 8. Appendix).

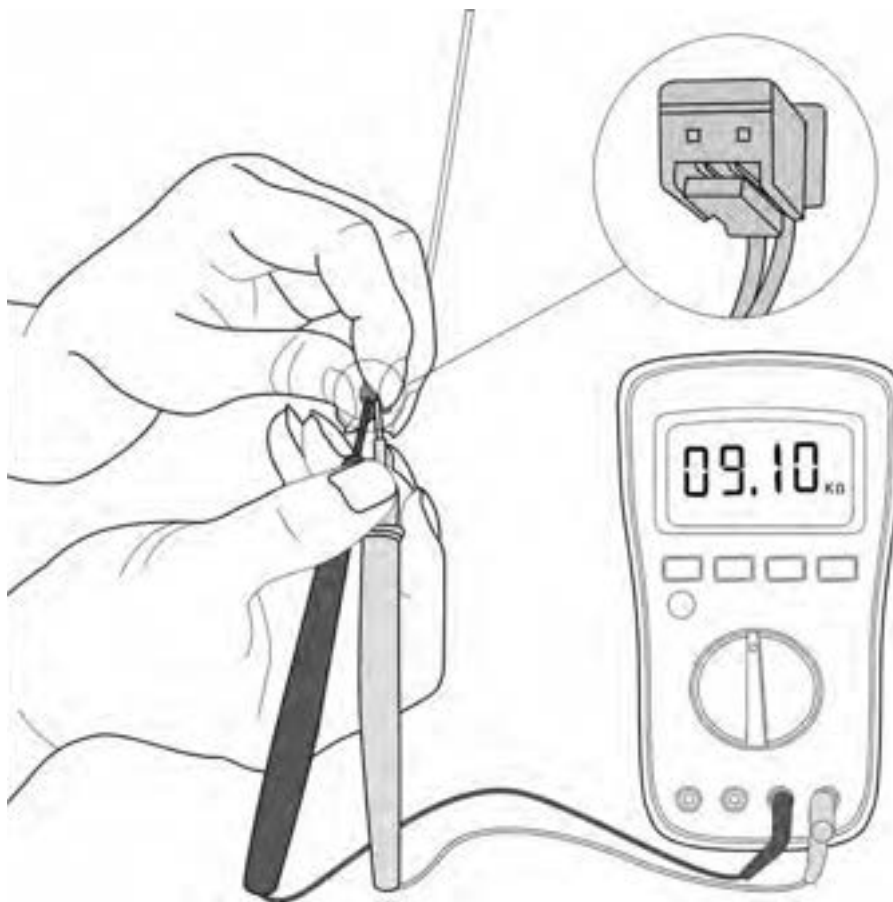

Note: The picture and the value are only for reference, actual condition and specific value may vary.

8.2 Compressor Check

1. Disconnect the compressor power cord from outdoor PCB (Refer to Chapter 6. Outdoor Unit Disassembly).
2. Measure the resistance value of each winding using a multi-meter.
3. Check the resistance value of each winding in the following table.

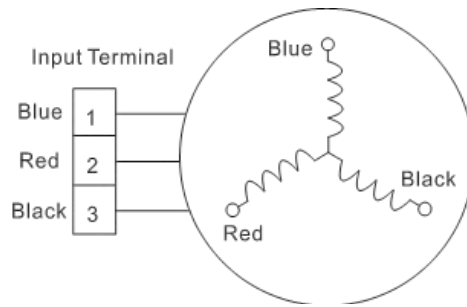

Resistance Value	ASM135D23UFZ	ATM115D43UFZ2	ASN98D22UFZ	ATQ360D1UMU
Blue-Red	1.75Ω	1.87Ω	1.57Ω	0.37Ω
Blue-Black				
Red-Black				

Resistance Value	ATF235D22UMT ATF250D22UMT KTF250D22UMT	ATF310D43UMT	KSK103D33UEZ3	ASM98D32UFZ
Blue-Red	0.75Ω	0.65Ω	2.13Ω	2.2Ω
Blue-Black				
Red-Black				

Resistance Value	ASN140D21UFZ KSN140D21UFZ	ASK89D29UEZD	KTM240D57UMT	KSN140D58UFZ
Blue-Red	1.28Ω	1.99Ω	0.62Ω	1.86Ω
Blue-Black				
Red-Black				

Resistance Value	KTF310D43UMT	ATN150D30UFZA KTM240D43UKT	KTM240D46UKT2	KTQ420D1UMU ATQ420D1SN5A1 EAPQ420D1UMUA EAPQ440D1UMUA
Blue-Red	0.65Ω	1.03Ω	1.04Ω	0.37Ω
Blue-Black				
Red-Black				



Note: The picture and the value are only for reference, actual condition and specific value may vary.

8.3 IPM Continuity Check

! WARNING

Electricity remains in capacitors even when the power supply is off. Ensure the capacitors are fully discharged before troubleshooting.

1. Turn off outdoor unit and disconnect power supply.
2. Discharge electrolytic capacitors and ensure all energy-storage unit has been discharged.
3. Disassemble outdoor PCB or disassemble IPM board.
4. Measure the resistance value between P and U(V, W, N); U(V, W) and N.

Digital tester		Resistance value	Digital tester		Resistance value
(+)Red	(-)Black	∞ (Several MΩ)	(+)Red	(-)Black	∞ (Several MΩ)
P	N		N	U	
	U			V	
	V			W	
	W			-	

Or test the conductivity of IPM with diode mode.

Needle-type Tester		Normal Value	Needle-type Tester		Normal Value
Red	Black		Red	Black	
P	U	Open-circuit	N	U	0.3-0.5V
	V			V	
	W			W	
Needle-type Tester		Normal Value	Needle-type Tester		Normal Value
Black	Red		Black	Red	
P	U	0.3-0.5V	N	U	Open-circuit
	V			V	
	W			W	

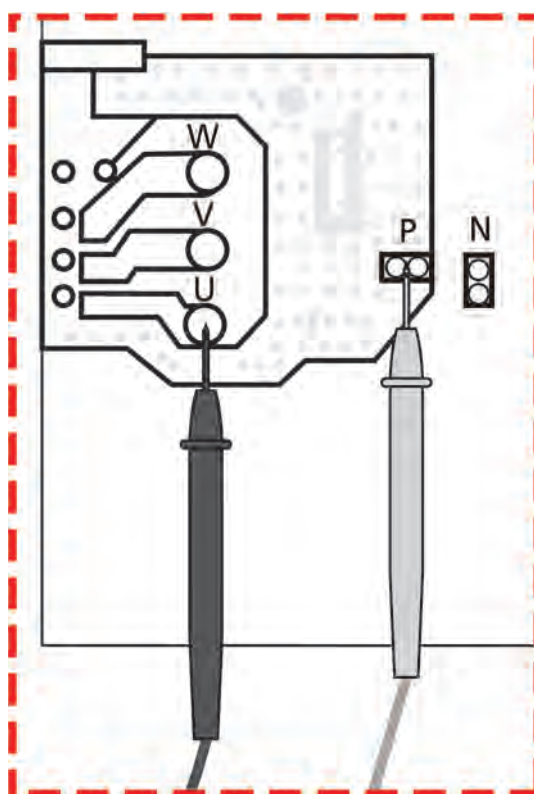

Note: The picture and the value are only for reference, actual condition and specific value may vary.

8.4 Normal voltage of P and N

	208-240V(1-phase)
In standby	
	around 310VDC
In operation	
	>310VDC

8.5 4-way Valve Check

1. Power on, use a digital tester to measure the voltage, when the unit operates in cooling, it is 0V. When the unit operates in heating, it is about 230VAC.

If the value of the voltage is not in the range, the PCB must have problems and need to be replaced.



2 Turn off the power, use a digital tester to measure the resistance. The value should be 1.8~2.5 K Ω .



8.6 EEV Check

! WARNING

**Electricity remains in capacitors even when the power supply is off.
Ensure the capacitors are fully discharged before troubleshooting.**

1. Disconnect the connector from outdoor PCB.
2. Measure the resistance value of each winding using a multi-meter.
3. Check the resistance value of each winding in the following table.

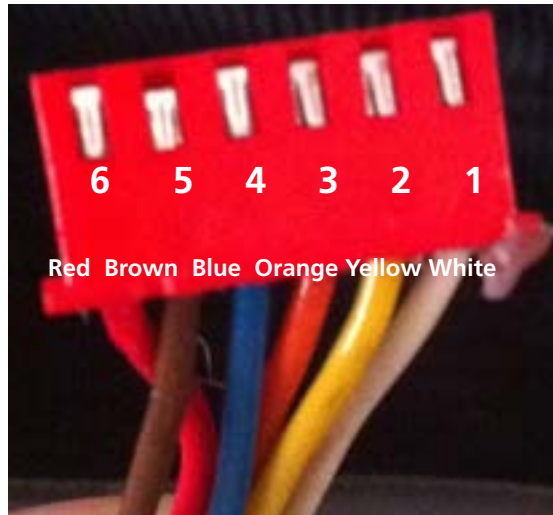

Color of lead winding	Normal Value
Red- Blue	About 50Ω
Red - Yellow	
Brown-Orange	
Brown-White	

8.7 Fuse of Electric Auxiliary Heat Module Check(Optional)

1. Disassemble the fuse from electric auxiliary heat module.
2. Use the multimeter signal gear to check whether there is a signal, if not, fuse is broken.



Indoor Unit Disassembly-Air Handle

Contents

1.	Indoor Unit Disassembly	1
1.1	Electrical Parts	2
1.2	Fan Motor and Fan	5
1.3	Evaporator.....	7
1.4	Electric Auxiliary Heat Module (Optional)	9

1. Indoor Unit Disassembly

1.1 Electrical Parts (Antistatic gloves must be worn.)

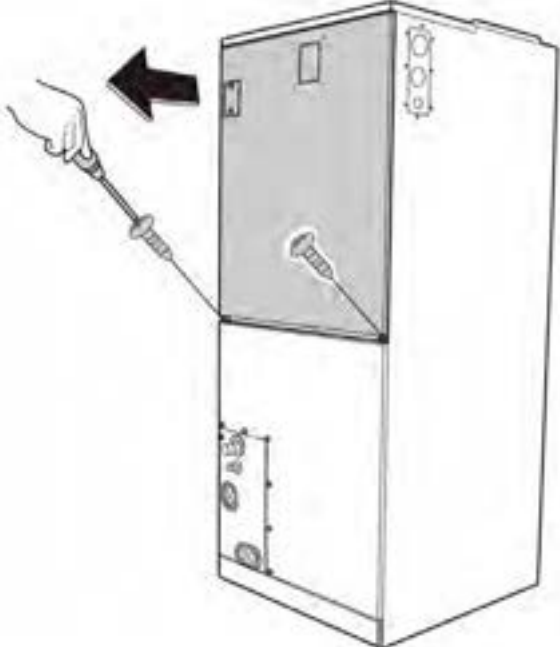
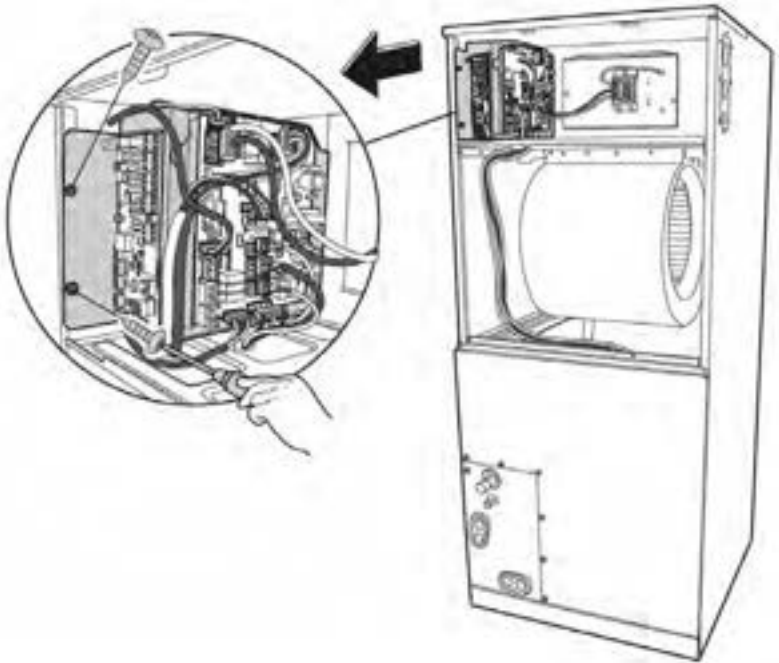
Procedure	Illustration
<p>1) Remove 2 screws of the upper cover Plate assembly and then remove the it. (see CJ_AHU_001)</p>	 <p>CJ_AHU_001</p>
<p>2) Remove 2 screws and unplug the plugs. (see CJ_AHU_002)</p> <p>3) Pull out the electric control box subassembly. (see CJ_AHU_002)</p>	 <p>CJ_AHU_002</p>

Note: This section is for reference only. Actual unit appearance may vary.

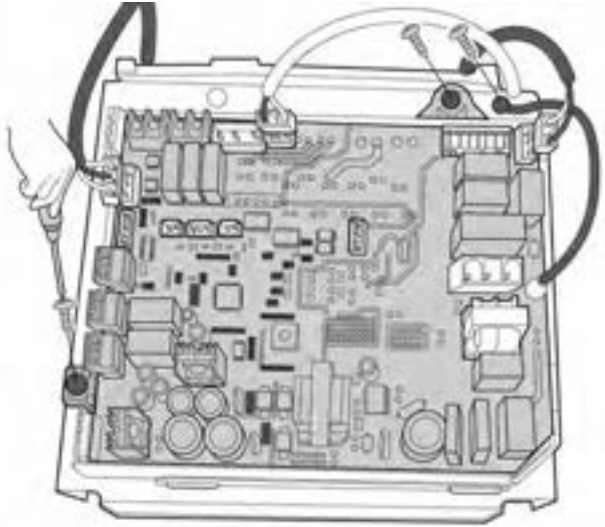
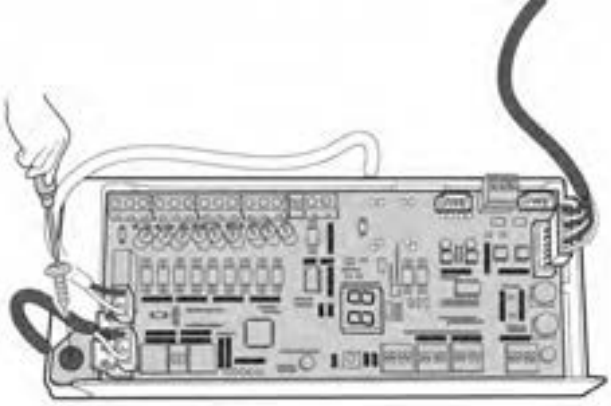
Procedure	Illustration
<p>4) Release 2 fixing screws and 1 earthing screw.(see CJ_AHU_003)</p> <p>5) Unplug the plugs and then remove the main control board subassembly. (see CJ_AHU_003)</p>	 <p style="text-align: center;">CJ_AHU_003</p>
<p>6) Release 1 fixing screw of the data transfer module control board to remove it. (see CJ_AHU_004)</p>	 <p style="text-align: center;">CJ_AHU_004</p>

Note: This section is for reference only. Actual unit appearance may vary.

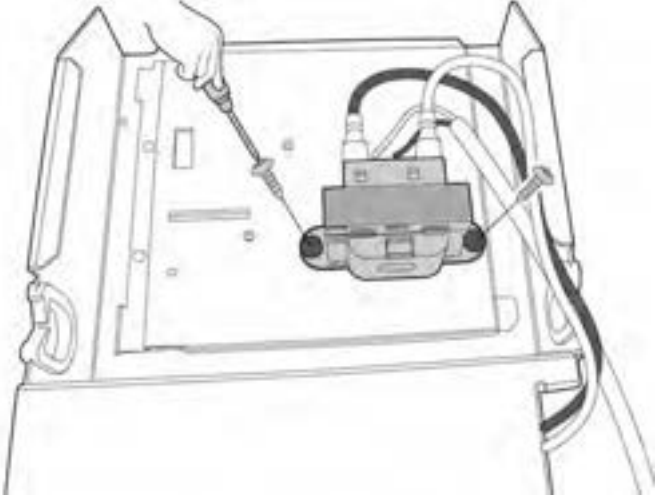
Procedure	Illustration
<p>7) Release 2 screws and then remove the transformer. (see CJ_AHU_005)</p>	 <p>CJ_AHU_005</p>

Note: This section is for reference only. Actual unit appearance may vary.

1.2 Fan Motor and Fan

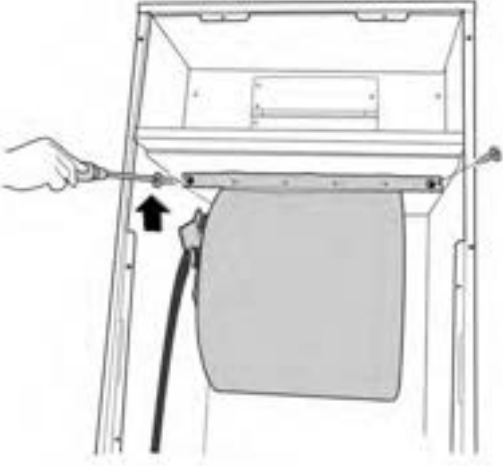
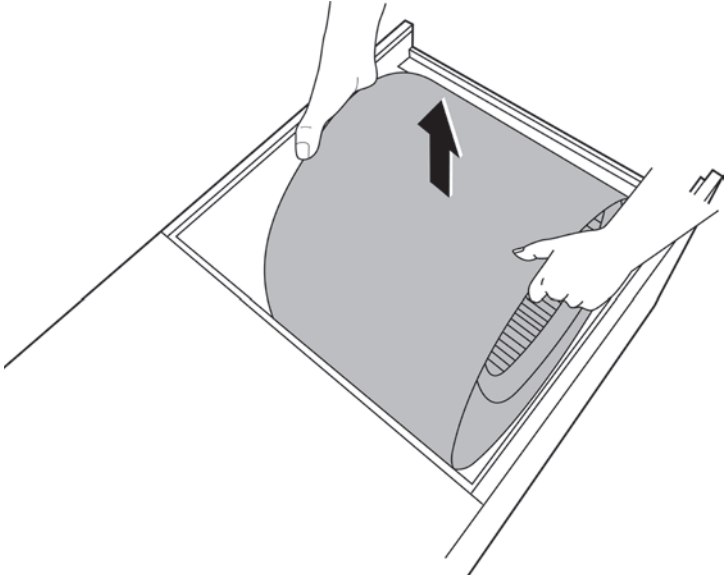
Procedure	Illustration
<p>1) Remove 2 screws of fan assembly (see CJ_AHU_006)</p>	 <p>CJ_AHU_006</p>
<p>2) Take out the fan assembly (see CJ_AHU_007)</p>	 <p>CJ_AHU_007</p>

Note: This section is for reference only. Actual unit appearance may vary.

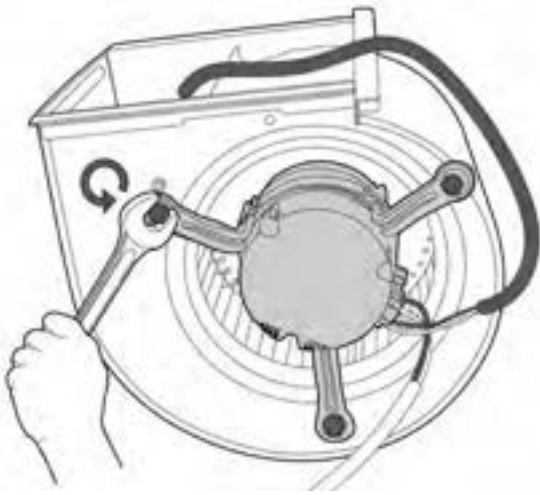
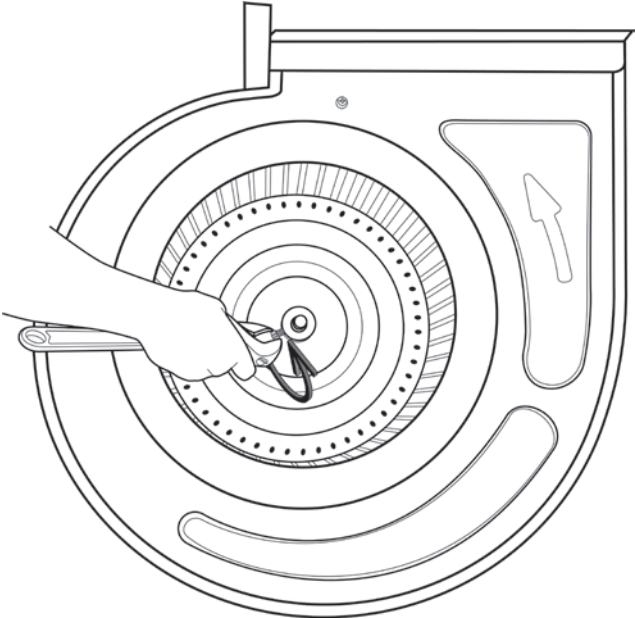
Procedure	Illustration
<p>3) Release 3 nuts fixing the fan motor and then take out the fan motor. (see CJ_AHU_008)</p>	 <p>CJ_AHU_008</p>
<p>4) Release the 1 nut fixing the fan and then take out the fan. (see CJ_AHU_009)</p>	 <p>CJ_AHU_009</p>

Note: This section is for reference only. Actual unit appearance may vary.

1.4 Evaporator

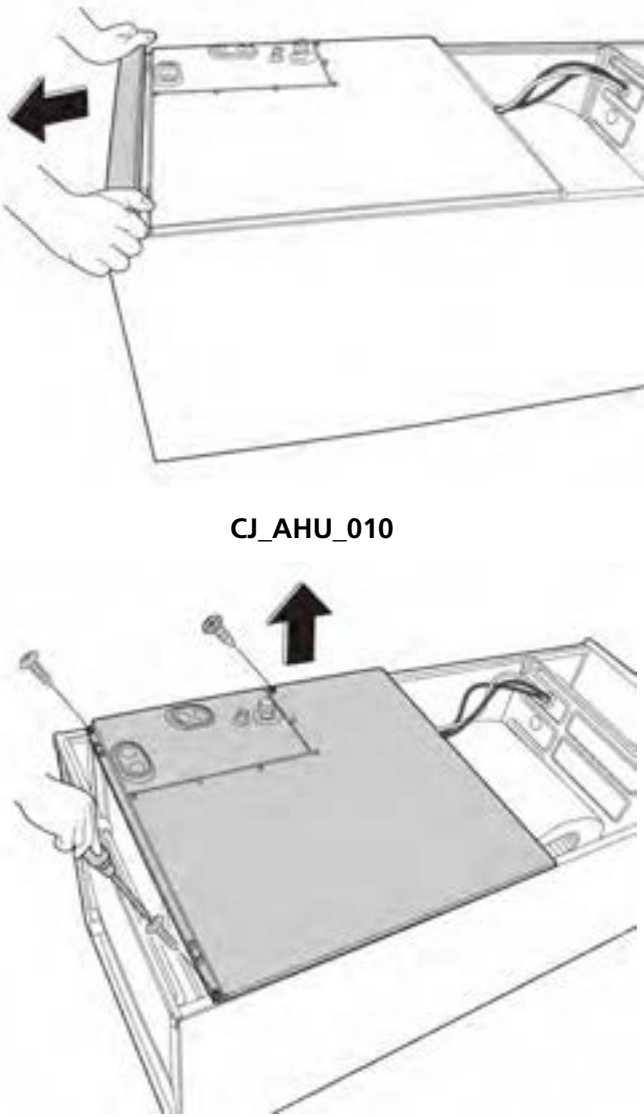
Procedure	Illustration
<p>1) Remove the cover plate (see CJ_AHU_010)</p> <p>2) Remove 3 screws of cover plate assembly(below) (see CJ_AHU_011)</p>	 <p>CJ_AHU_010</p> <p>CJ_AHU_011</p>

Note: This section is for reference only. Actual unit appearance may vary.

1.5 Electric Auxiliary Heat Module (Optional)

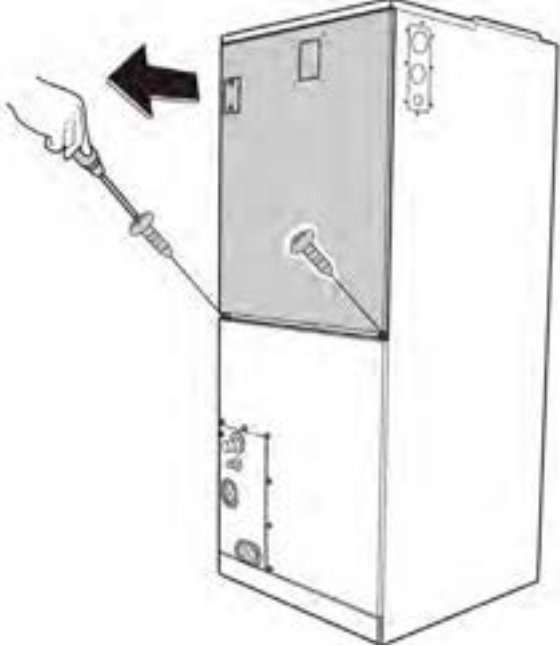
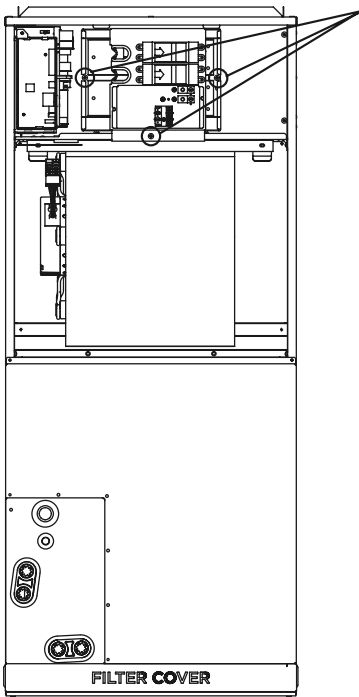
Procedure	Illustration
<p>1) Remove 2 screws of the upper cover Plate assembly and then remove the it. (see CJ_AHU_001)</p>	 <p>CJ_AHU_001</p>
<p>2) Remove 3 fixing screws. (see CJ_AHU_014)</p>	 <p>screws</p> <p>FILTER COVER</p> <p>CJ_AHU_014</p>

Note: This section is for reference only. Actual unit appearance may vary.

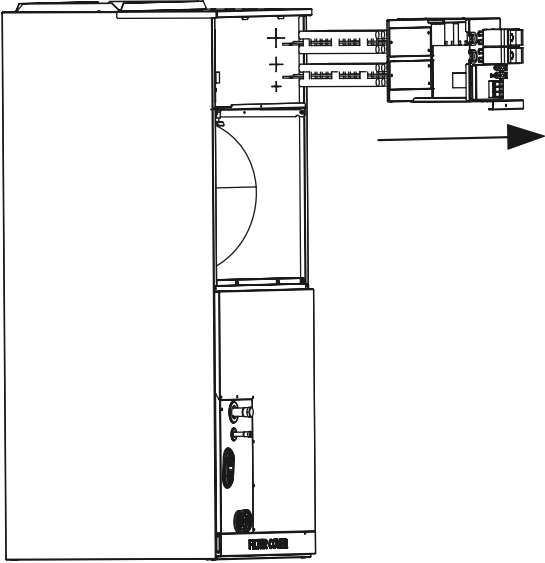
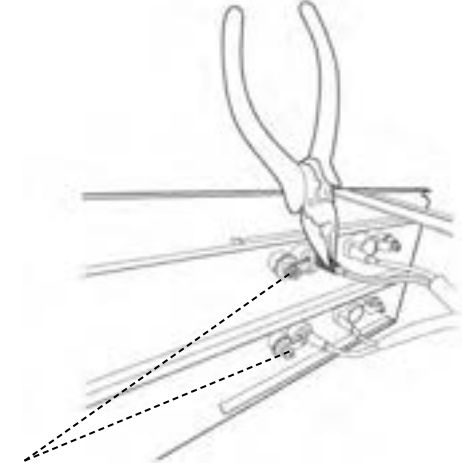
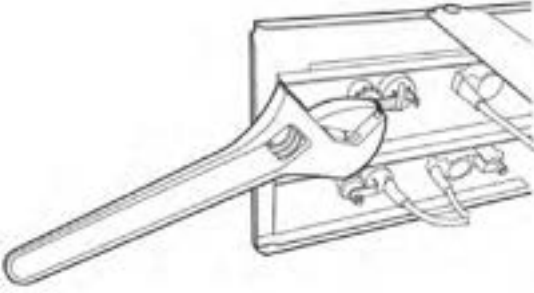
Procedure	Illustration
<p>3) Pull out the auxiliary heat module. (see CJ_AHU_015)</p>	 <p style="text-align: center;">CJ_AHU_015</p>
<p>4) Pull out the wire connect to the fuse with needle-nose pliers(see CJ_AHU_016)</p> <p>Note: Qty of EAH-03B&EAH-05B is 1, Qty of EAH-08B&EAH-10B is 2, Qty of EAH-15B is 3, Qty of EAH-20B is 4, Qty of EAH-25B is 5.</p>	 <p style="text-align: center;">CJ_AHU_016</p>
<p>5) Loosen the retaining nut, and then remove the fuse. (see CJ_AHU_017)</p>	 <p style="text-align: center;">CJ_AHU_017</p>

Note: This section is for reference only. Actual unit appearance may vary.

Outdoor Unit Disassembly

Contents

1.	Outdoor Unit Table	2
2.	Outdoor Unit Disassembly	3
2.1	Panel Plate.....	3
2.2	Electrical Parts	20
2.3	Fan Assembly	47
2.4	Fan Motor	48
2.5	Sound Blanket.....	49
2.6	Four-way Valve	50
2.7	Compressor.....	51

1. Outdoor Unit Disassembly

1.1 Outdoor Unit Table

Outdoor Unit Model	Panel Plate	PCB Board
CPR18CD(O)	X330	PCB Board 11
CPH18CD(O)	X430	PCB Board 3
CPH24CD(O)	D30	PCB Board 14
CPR24CD(O)	X430	PCB Board 3
CPH30CD(O)	D30	PCB Board 14
CPH30CD(O)	D30	PCB Board 14
CPR36CD(O)	D30	PCB Board 14
CPH36CD(O)	E30	PCB Board 8
CPH48CD(O)	E30	PCB Board 8
CPR48CD(O)	E30	PCB Board 8
CPR60CD(O)	E30	PCB Board 8
CPH60CD(O)	E30	PCB Board 8

2. Outdoor Unit Disassembly

2.1 Panel Plate

1. X230/X330

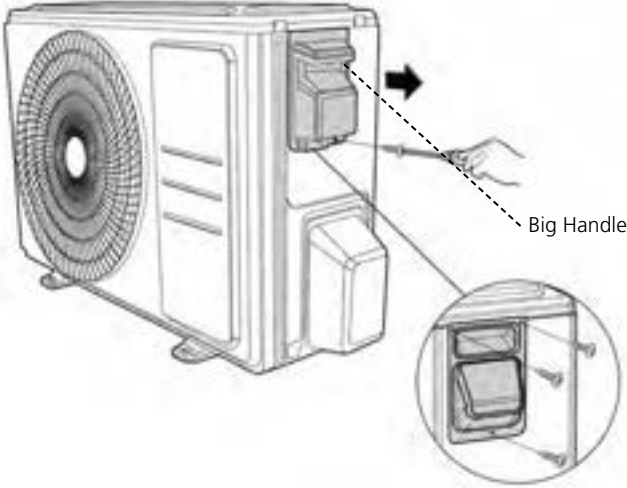
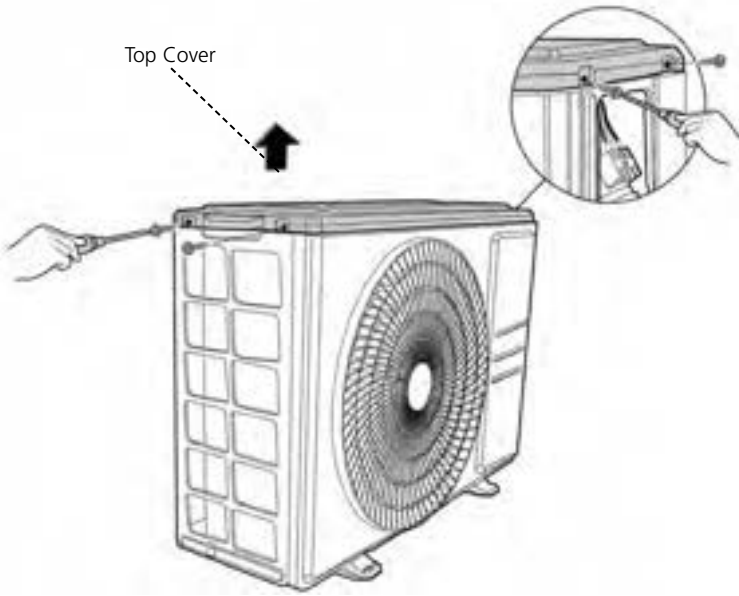
Procedure	Illustration
<p>1) Turn off the air conditioner and the power breaker.</p> <p>2) Remove the screw of the big handle and then remove the big handle (1 screws) (see CJ_X230_001).</p>	 <p style="text-align: center;">CJ_X230_001</p>
<p>3) Remove the screws of the top cover and then remove the top cover (4 screws). One of the screws is located underneath the big handle (see CJ_X230_002).</p>	 <p style="text-align: center;">CJ_X230_002</p>

Note: This section is for reference only. Actual unit appearance may vary.

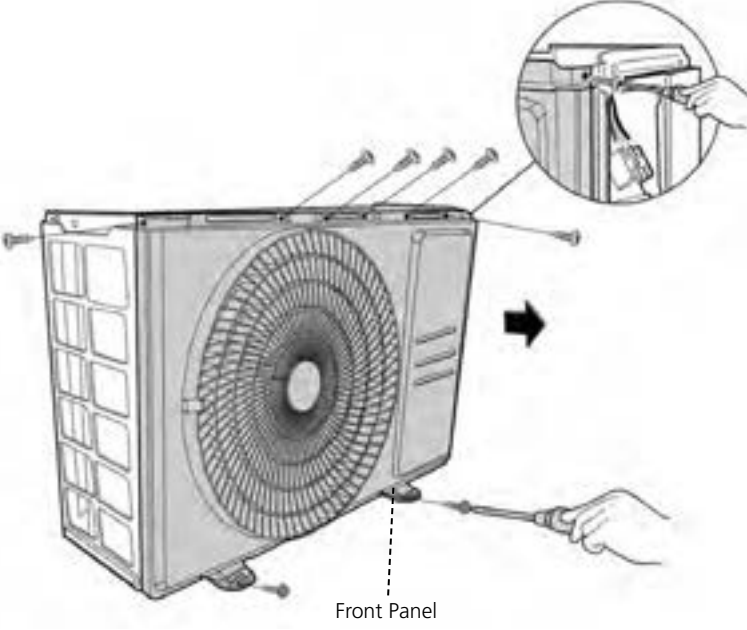
Procedure	Illustration
<p>4) Remove the screws of water collecting cover and then remove the water collecting cover (2 screws) (see CJ_X230_003).</p>	 <p style="text-align: center;">CJ_X230_003</p>
<p>5) Remove the screws of the front panel and then remove the front panel (7 screws(onoff models) or 9 screws(inverter models) (see CJ_X230_004).</p>	 <p style="text-align: center;">CJ_X230_004</p>

Note: This section is for reference only. Actual unit appearance may vary.

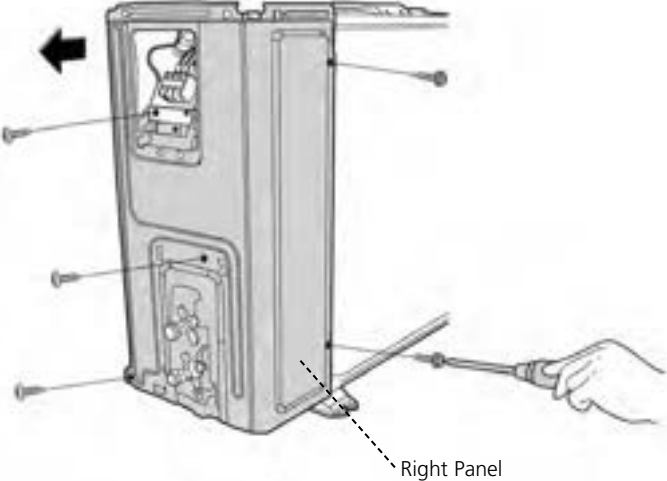
Procedure	Illustration
<p>6) Remove the screws of the right panel and then remove the right panel (5 screws) (see CJ_X230_005).</p>	 <p>CJ_X230_005</p>

Note: This section is for reference only. Actual unit appearance may vary.

2.X430

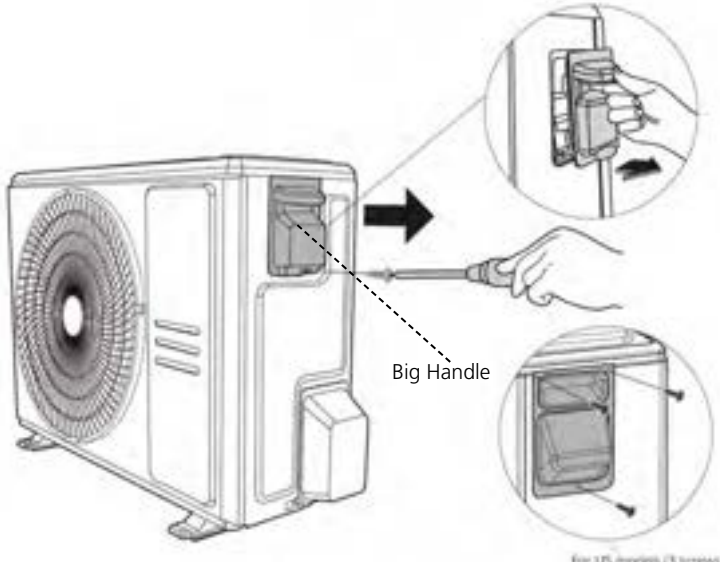
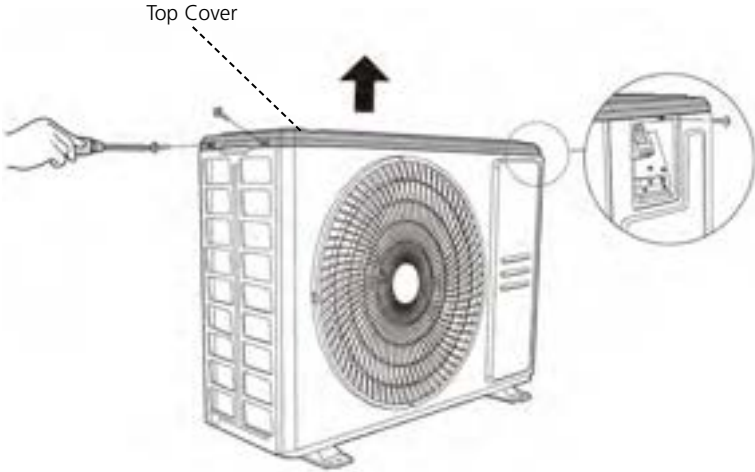
Procedure	Illustration
<p>1) Turn off the air conditioner and the power breaker.</p> <p>2) Remove the screw of the big handle and then remove the big handle (1 screw) (see CJ_X430_001).</p>	 <p style="text-align: center;">CJ_X430_001</p>
<p>3) Remove the screws of the top cover and then remove the top cover (3 screws). One of the screws is located underneath the big handle (see CJ_X430_002).</p>	 <p style="text-align: center;">CJ_X430_002</p>

Note: This section is for reference only. Actual unit appearance may vary.

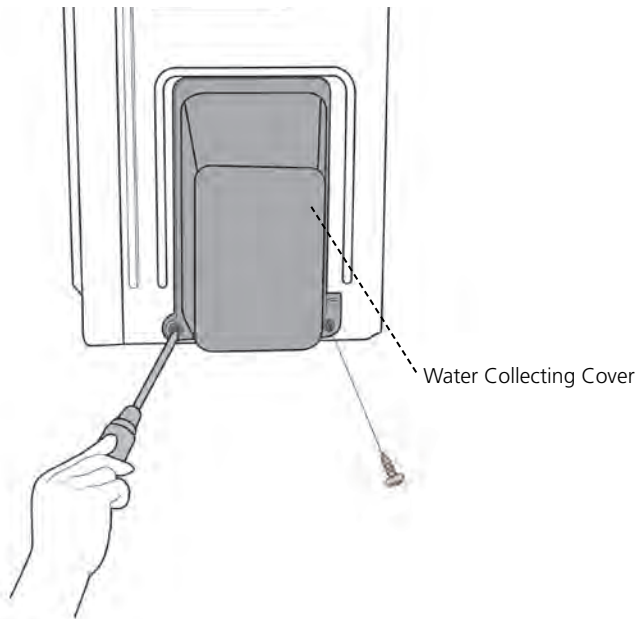
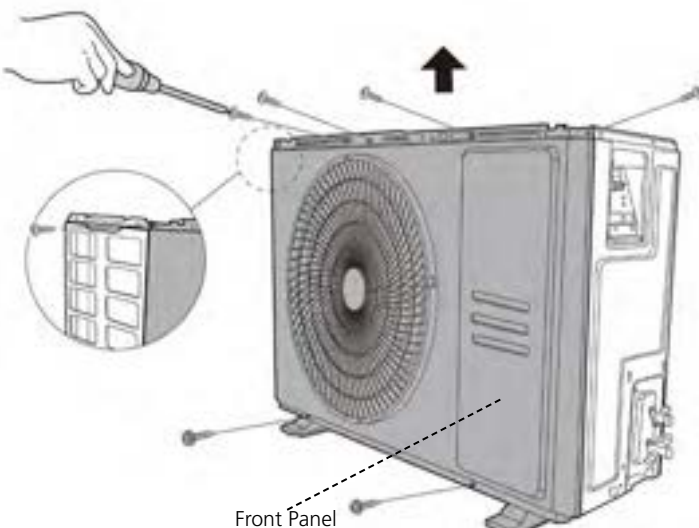
Procedure	Illustration
<p>4) Remove the screws of water collecting cover and then remove the water collecting cover (2 screws) (see CJ_X430_003).</p>	 <p style="text-align: center;">CJ_X430_003</p>
<p>5) Remove the screws of the front panel and then remove the front panel (7 screws(onoff models) or 9 screws(inverter models) (see CJ_X430_004).</p>	 <p style="text-align: center;">CJ_X430_004</p>

Note: This section is for reference only. Actual unit appearance may vary.

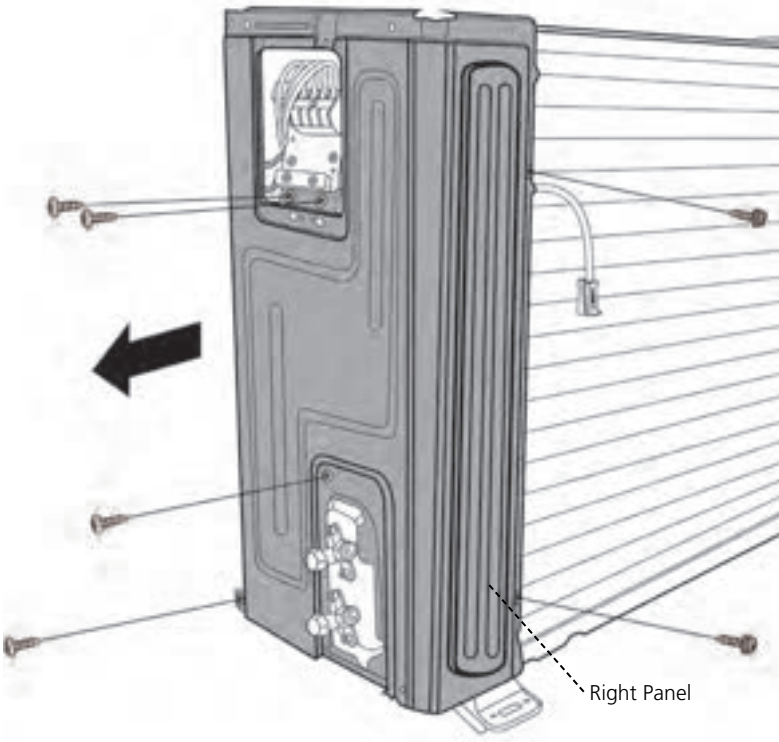
Procedure	Illustration
<p>6) Remove the screws of the right panel and then remove the right panel (6 screws) (see CJ_X430_005).</p>	 <p data-bbox="930 1160 1102 1189">CJ_X430_005</p>

Note: This section is for reference only. Actual unit appearance may vary.

3. D30

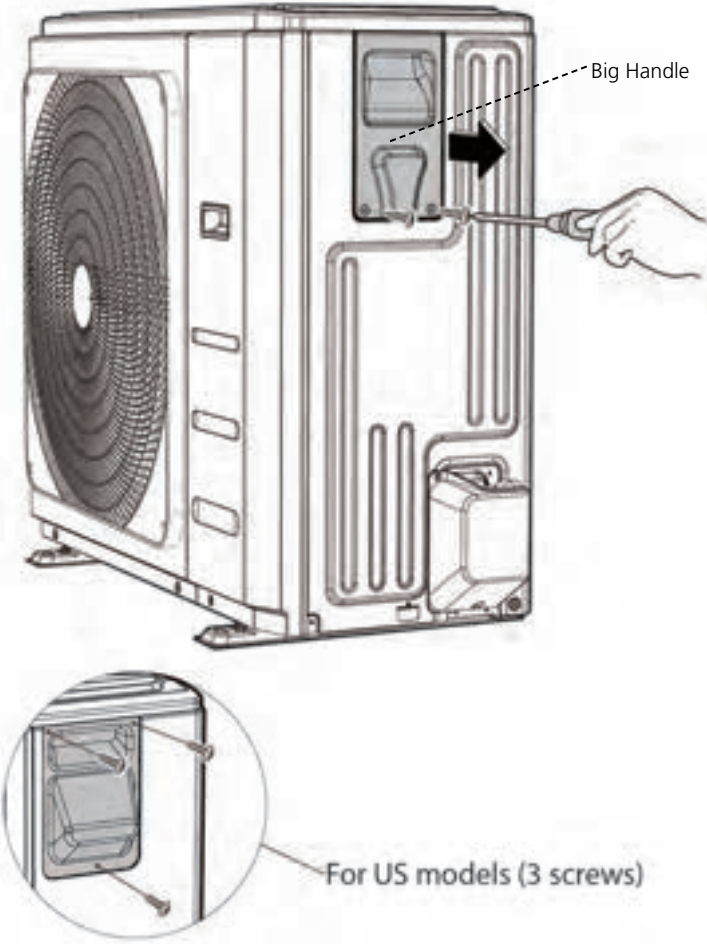
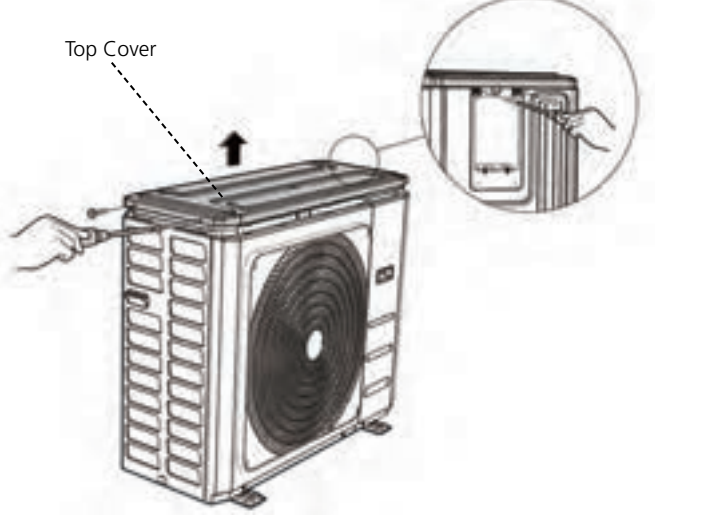
Procedure	Illustration
<p>1) Turn off the air conditioner and the power breaker.</p> <p>2) Remove the screws of the big handle and then remove the big handle (2 screws) (see CJ_D30_001).</p>	 <p style="text-align: center;">CJ_D30_001</p>
<p>3) Remove the screws of the top cover and then remove the top cover (4 screws). Two of the screws is located underneath the big handle (see CJ_D30_002).</p>	 <p style="text-align: center;">CJ_D30_002</p>

Note: This section is for reference only. Actual unit appearance may vary.

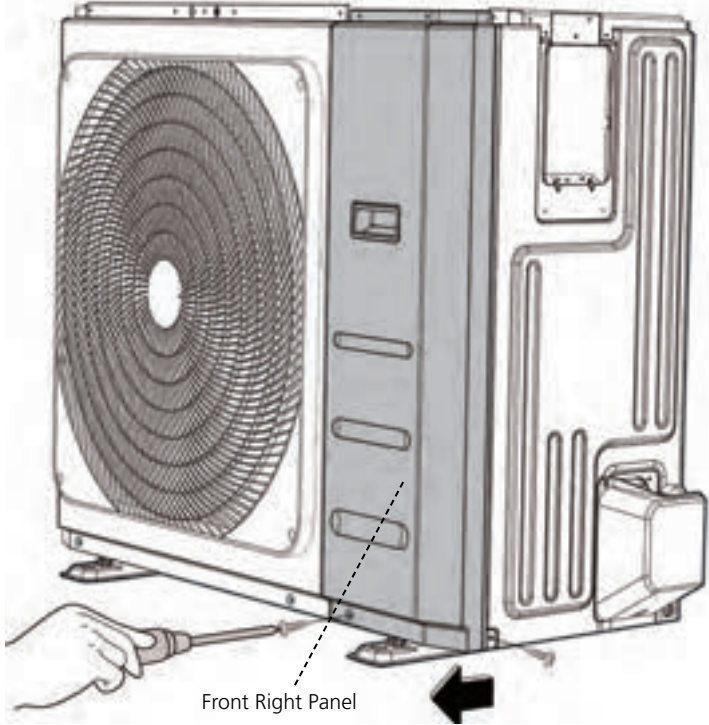
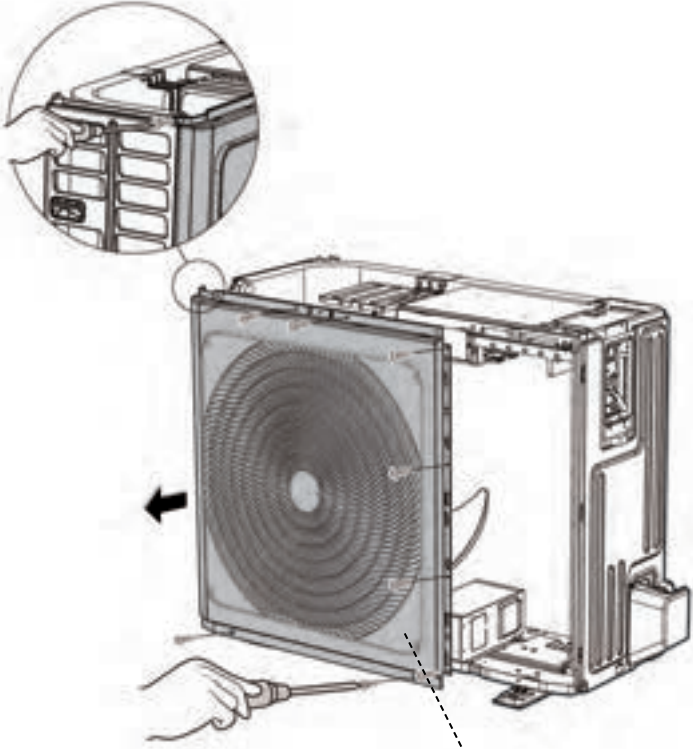
Procedure	Illustration
<p>4) Remove the screws of the front right panel and then remove the front right panel (2 screws) (see CJ_D30_003).</p>	 <p style="text-align: center;">CJ_D30_003</p>
<p>5) Remove the screws of the front panel and then remove the front panel (9 screws) (see CJ_D30_004).</p>	 <p style="text-align: center;">CJ_D30_004</p>

Note: This section is for reference only. Actual unit appearance may vary.

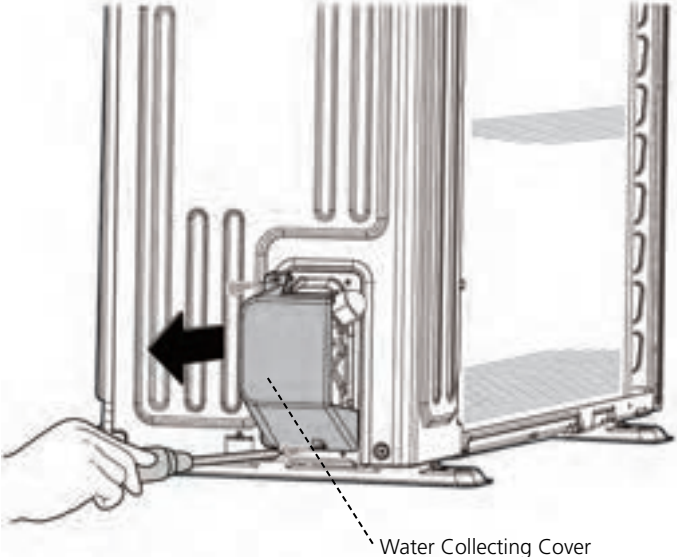
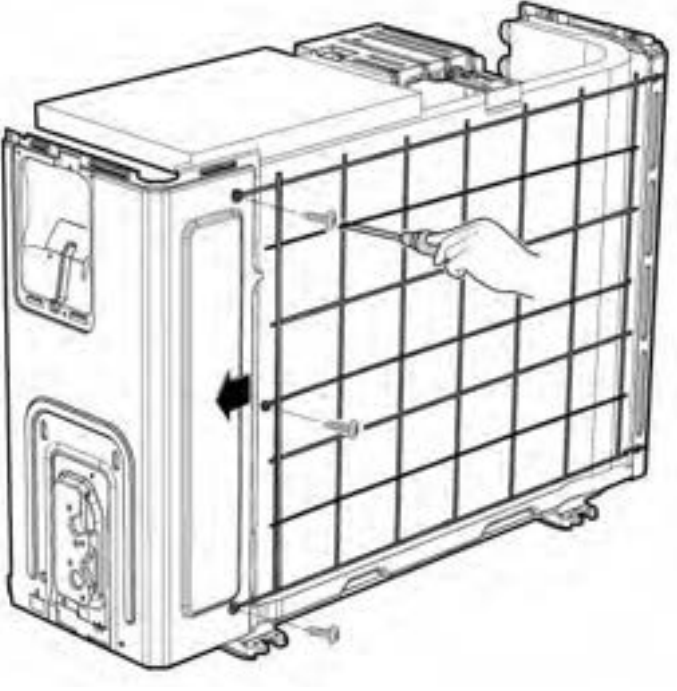
Procedure	Illustration
<p>6) Remove the screws of water collecting cover and then remove the water collecting cover (2 screws) (see CJ_D30_005).</p>	 <p style="text-align: center;">CJ_D30_005</p>
<p>7) Remove the screws of the rear net and then remove the rear net (2 screws) (see CJ_D30_006). (for some models)</p>	 <p style="text-align: center;">CJ_D30_006</p>

Note: This section is for reference only. Actual unit appearance may vary.

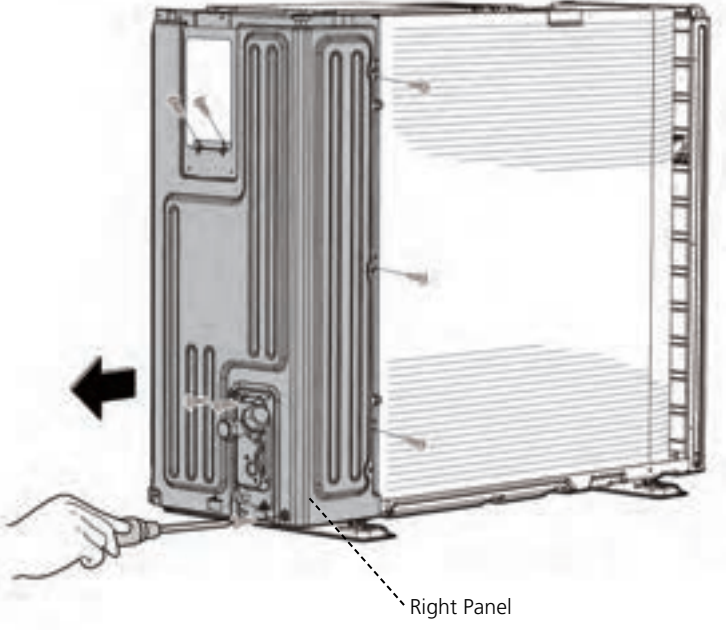
Procedure	Illustration
<p>8) Remove the screws of the right panel and then remove the right panel (8 screws) (see CJ_D30_007).</p>	 <p data-bbox="938 1093 1093 1131">CJ_D30_007</p>

Note: This section is for reference only. Actual unit appearance may vary.

4. X630

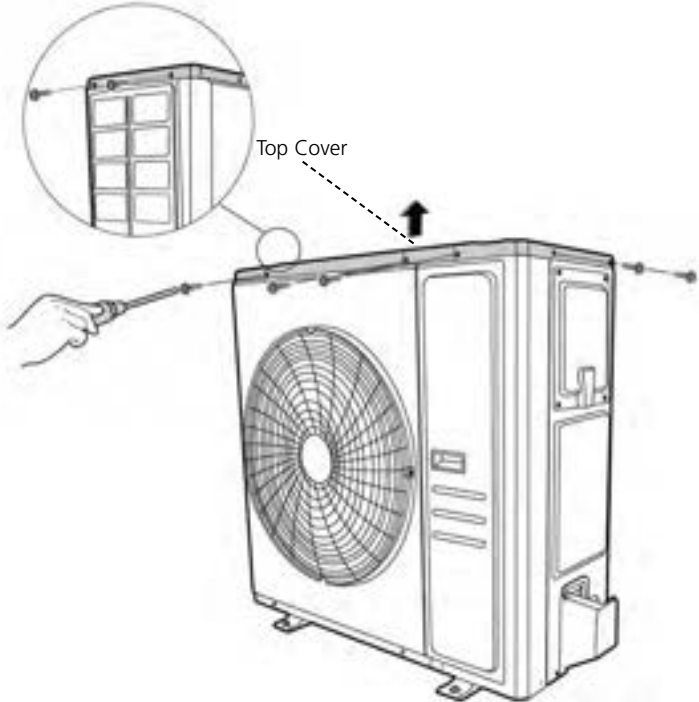
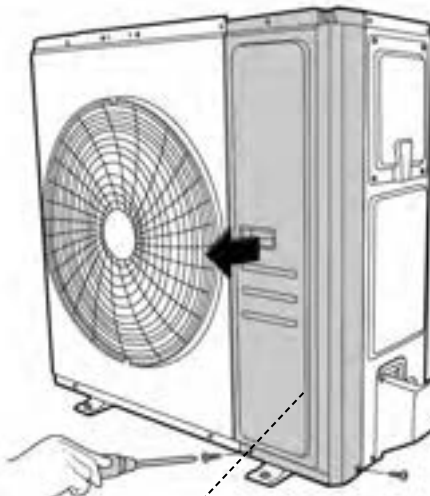
Procedure	Illustration
<p>1) Turn off the air conditioner and the power breaker.</p> <p>2) Remove the screws of the top cover and then remove the top cover (7 screws). (see CJ_X630_001).</p>	 <p style="text-align: center;">CJ_X630_001</p>
<p>3) Remove the screws of the front right panel and then remove the front right panel (2 screws) (see CJ_X630_002).</p>	 <p style="text-align: center;">CJ_X630_002</p>

Note: This section is for reference only. Actual unit appearance may vary.

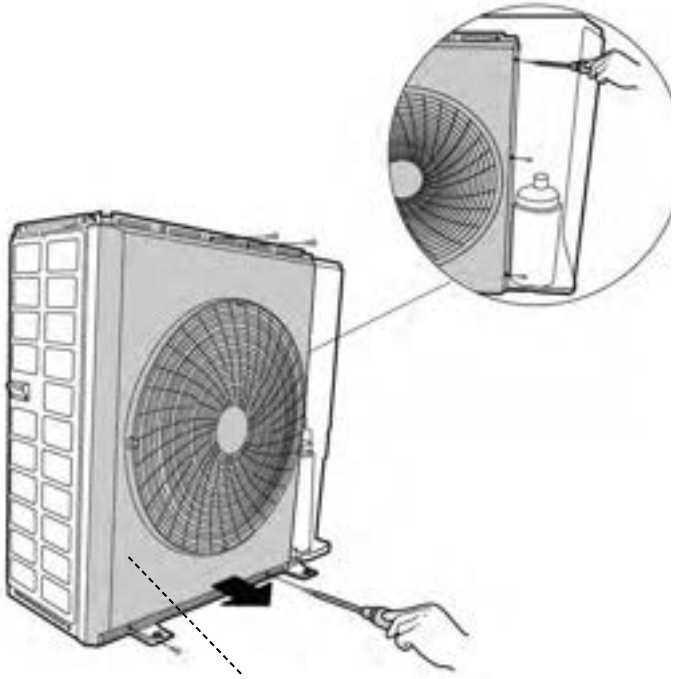
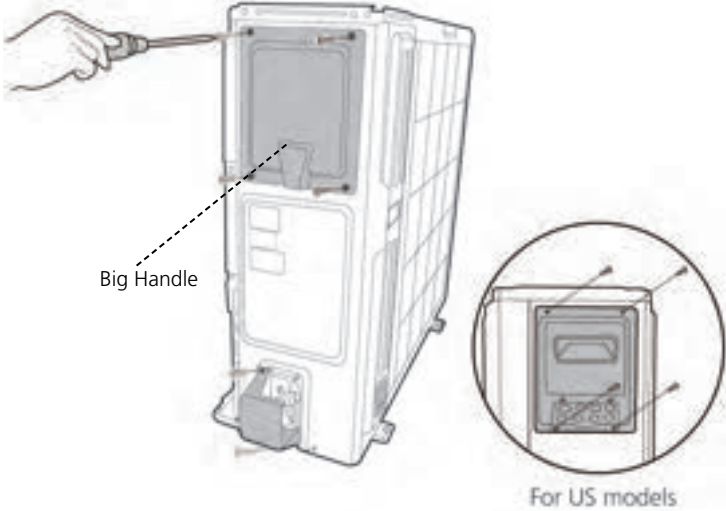
Procedure	Illustration
<p>4) Remove the screws of the front panel and then remove the front panel (8 screws) (see CJ_X630_003).</p>	 <p style="text-align: center;">Front Panel</p> <p style="text-align: center;">CJ_X630_003</p>
<p>5) Remove the screws of the big handle and then remove the big handle (4 screws) (see CJ_X630_004).</p>	 <p style="text-align: center;">Big Handle</p> <p style="text-align: center;">For US models</p> <p style="text-align: center;">CJ_X630_004</p>

Note: This section is for reference only. Actual unit appearance may vary.

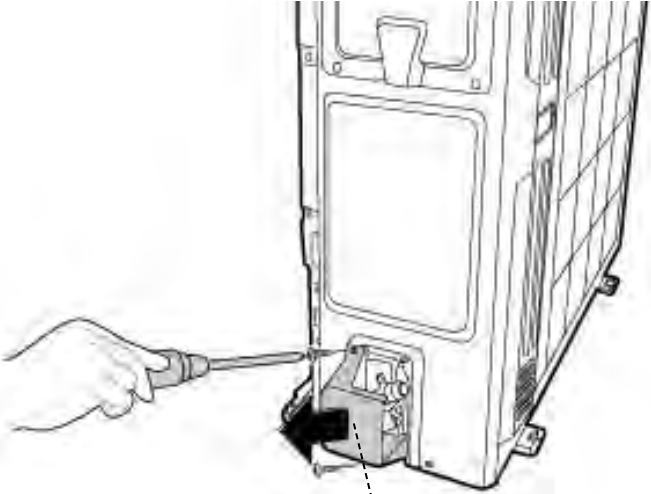
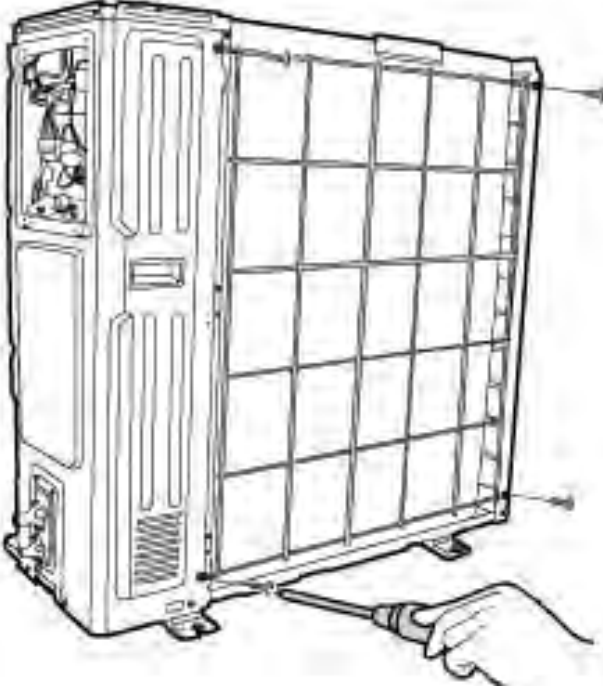
Procedure	Illustration
<p>6) Remove the screws of water collecting cover and then remove the water collecting cover (2 screws) (see CJ_X630_005).</p>	 <p data-bbox="932 925 1182 987">Water Collecting Cover CJ_X630_005</p>
<p>7) Remove the screws of the rear net and then remove the rear net (4 screws) (see CJ_X630_006). (for some models)</p>	 <p data-bbox="932 1803 1102 1832">CJ_X630_006</p>

Note: This section is for reference only. Actual unit appearance may vary.

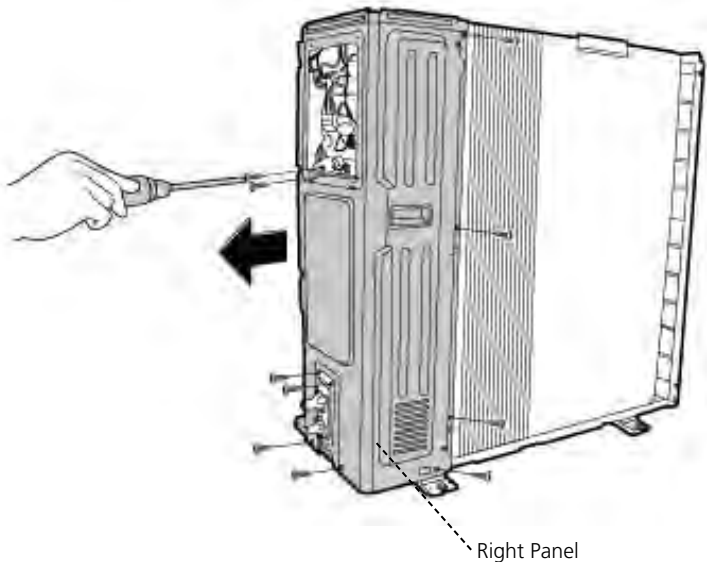
Procedure	Illustration
<p>8) Remove the screws of the right panel and then remove the right panel (10 screws) (see CJ_X630_007).</p>	 <p data-bbox="1129 925 1235 952">Right Panel</p> <p data-bbox="930 1016 1099 1048">CJ_X630_007</p>

Note: This section is for reference only. Actual unit appearance may vary.

4. E30/590

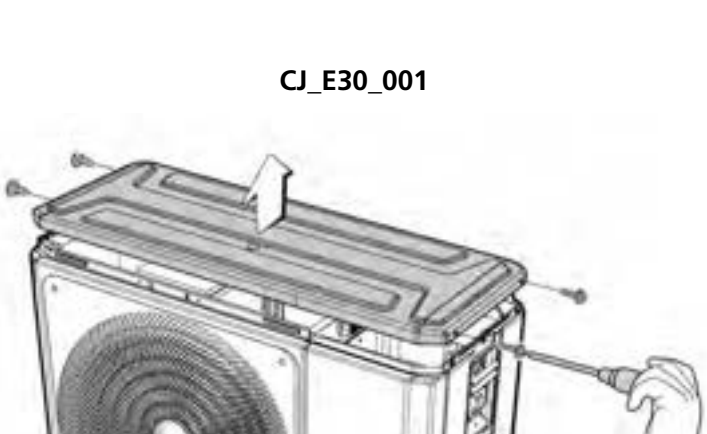
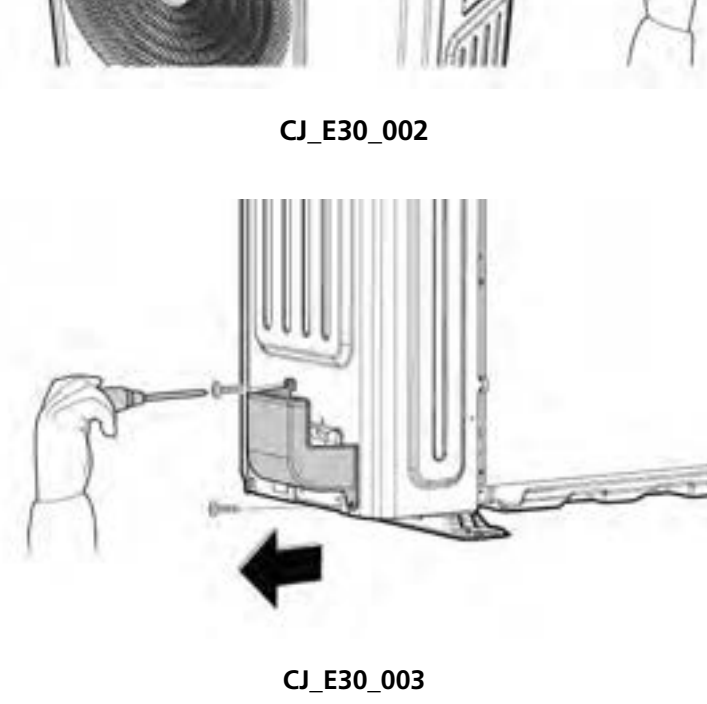
Procedure	Illustration
<p>1) Turn off the air conditioner and the power breaker.</p> <p>2) Remove the screws of the big handle and then remove the big handle (2 screws) (see CJ_E30_001).</p>	 <p style="text-align: center;">CJ_E30_001</p>
<p>3) Remove the screws of the top cover and then remove the top cover (4 screws). Two of the screws is located underneath the big handle (see CJ_E30_002).</p>	 <p style="text-align: center;">CJ_E30_002</p>
<p>4) Remove the screws of water collecting cover and then remove the water collecting cover (2 screw) (see CJ_E30_003).</p>	 <p style="text-align: center;">CJ_E30_003</p>

Note: This section is for reference only. Actual unit appearance may vary.

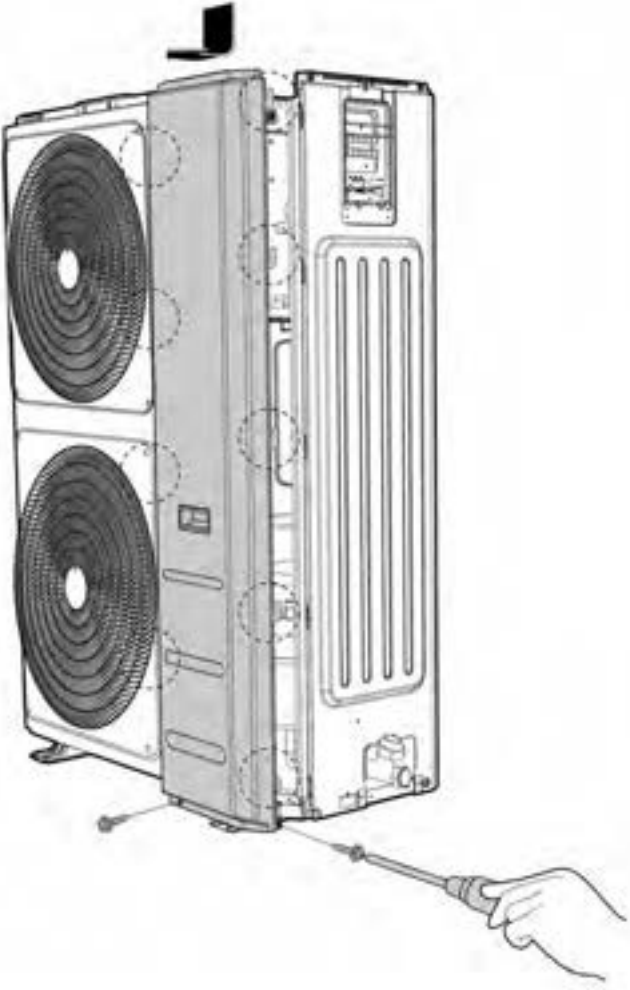
Procedure	Illustration
<p>1) Remove the screws of the front right panel and then remove the front right panel (2 screws) (see CJ_E30_004).</p>	 <p>The illustration shows a vertical outdoor air conditioning unit. A hand is using a screwdriver to remove screws from the front right panel. Dashed circles highlight the locations of the screws. The unit has two large circular fans on the left side and a control panel on the right. The label 'CJ_E30_004' is positioned below the illustration.</p> <p data-bbox="938 1355 1093 1388">CJ_E30_004</p>

Note: This section is for reference only. Actual unit appearance may vary.

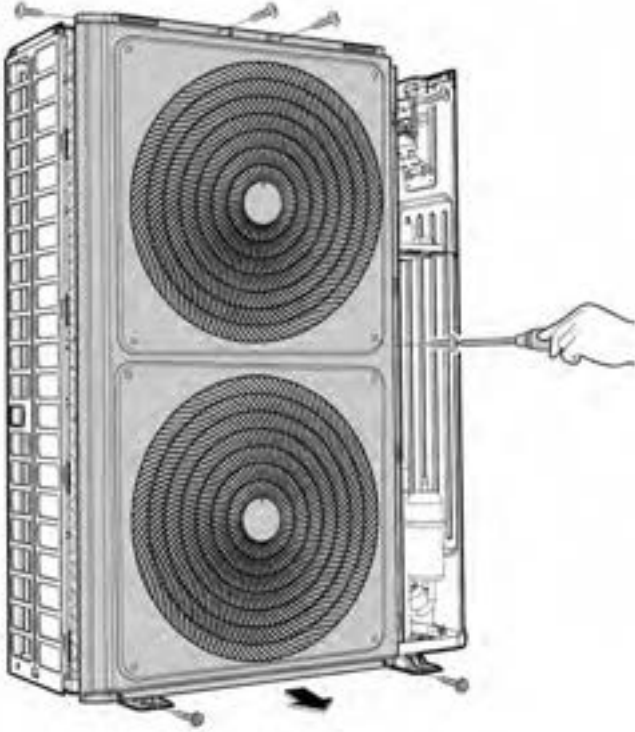
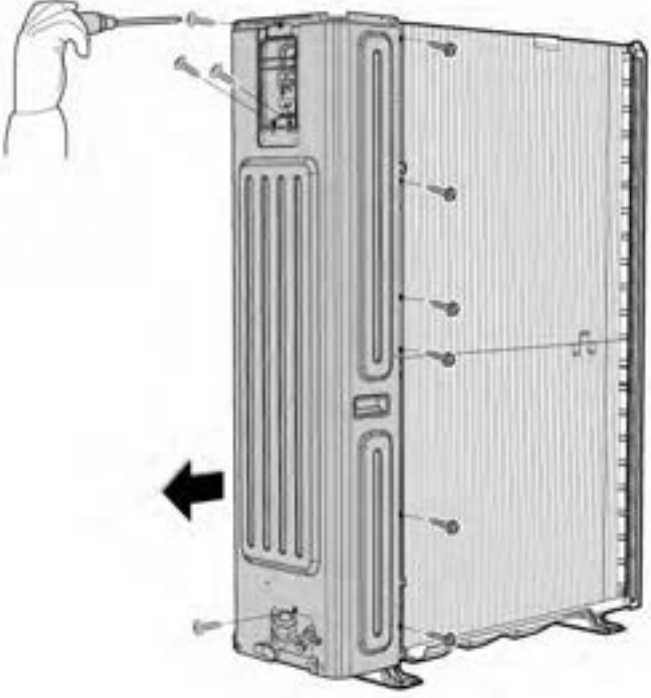
Procedure	Illustration
<p>2) Remove the screws of the front panel and then remove the front panel (7 screws) (see CJ_E30_005).</p>	 <p style="text-align: center;">CJ_E30_005</p>
<p>3) Remove the screws of the right panel and then remove the right panel (10 screws) (see CJ_E30_006).</p>	 <p style="text-align: center;">CJ_E30_006</p>

Note: This section is for reference only. Actual unit appearance may vary.

2.2 Electrical parts

⚠ WARNING: Antistatic gloves must be worn when you disassemble the electronic box.

Note: Remove the air outlet grille(refer to 3.1 Panel Plate) before disassembling electrical parts.

1. PCB board 1

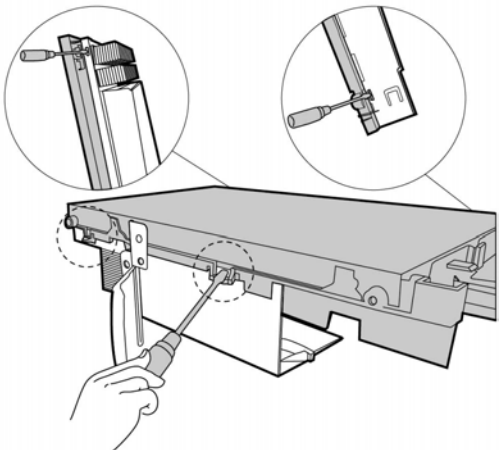
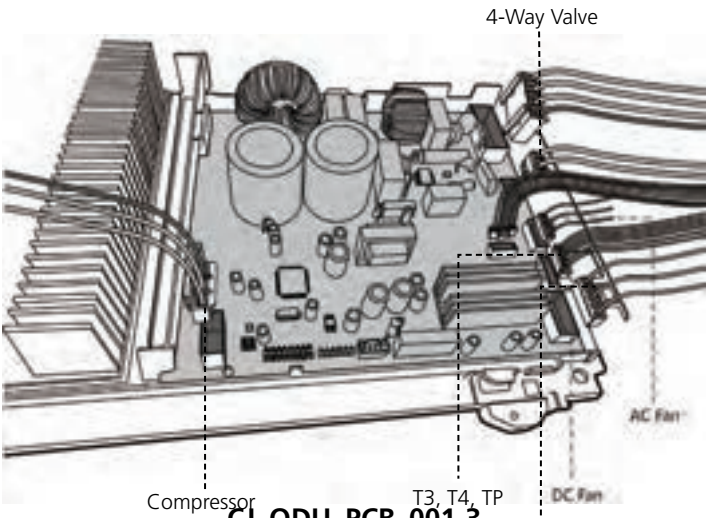
Procedure	Illustration
<p>1) Remove the screws of the top cover. (2 screws) (see CJ_ODU_PCB_001-1).</p>	 <p style="text-align: center;">CJ_ODU_PCB_001-1</p>
<p>2) Unfix the hooks and then open the electronic control box cover (4 hooks) (see CJ_ODU_PCB_001-2).</p>	 <p style="text-align: center;">CJ_ODU_PCB_001-2</p>
<p>3) Disconnect the connector for fan motor from the electronic control board (see CJ_ODU_PCB_001-3).</p> <p>4) Remove the connector for the compressor (see CJ_ODU_PCB_001-3).</p> <p>5) Pull out the two blue wires connected with the four way valve (CJ_ODU_PCB_001-3).</p> <p>6) Pull out connectors of the condenser coil temp. sensor(T3),outdoor ambient temp. sensor(T4) and discharge temp. sensor(TP) (CJ_ODU_PCB_001-3).</p> <p>7) Disconnect the electronic expansion valve wire (CJ_ODU_PCB_001-3).</p> <p>8) Then remove the electronic control board.</p>	 <p style="text-align: center;">CJ_ODU_PCB_001-3</p>

Note: This section is for reference only. Actual unit appearance may vary.

2. PCB board 2

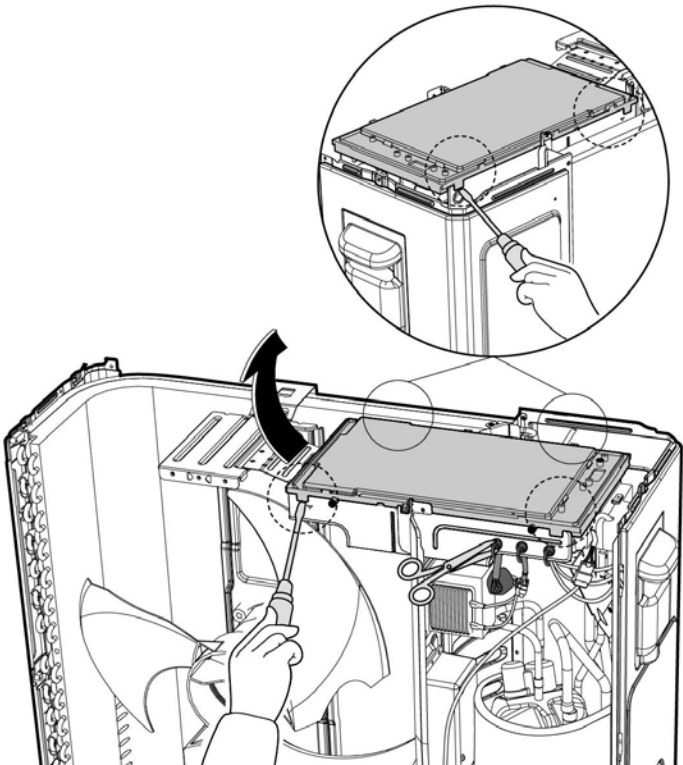
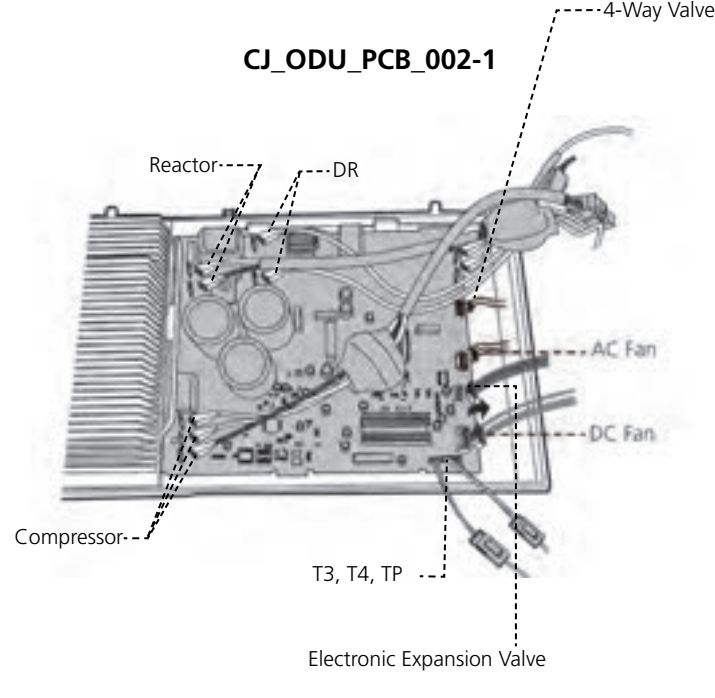
Procedure	Illustration
<p>1) Unfix the hooks and then open the electronic control box cover (4 hooks) (see CJ_ODU_PCB_002-1).</p>	
<p>2) Disconnect the connector for fan motor from the electronic control board (see CJ_ODU_PCB_002-2).</p> <p>3) Remove the connector for the compressor (see CJ_ODU_PCB_002-2).</p> <p>4) Pull out the two blue wires connected with the four way valve (see CJ_ODU_PCB_002-2).</p> <p>5) Pull out connectors of the condenser coil temp. sensor(T3), outdoor ambient temp. sensor(T4) and discharge temp. sensor(TP) (see CJ_ODU_PCB_002-2).</p> <p>6) Disconnect the electronic expansion valve wire (see Fig CJ_ODU_PCB_002-2).</p> <p>7) Then remove the electronic control board.</p>	 <p>CJ_ODU_PCB_002-1</p> <p>Reactor---DR</p> <p>4-Way Valve</p> <p>AC Fan</p> <p>DC Fan</p> <p>Compressor---</p> <p>T3, T4, TP ---</p> <p>Electronic Expansion Valve</p> <p>CJ_ODU_PCB_002-2</p>

Note: This section is for reference only. Actual unit appearance may vary.

3. PCB board 3

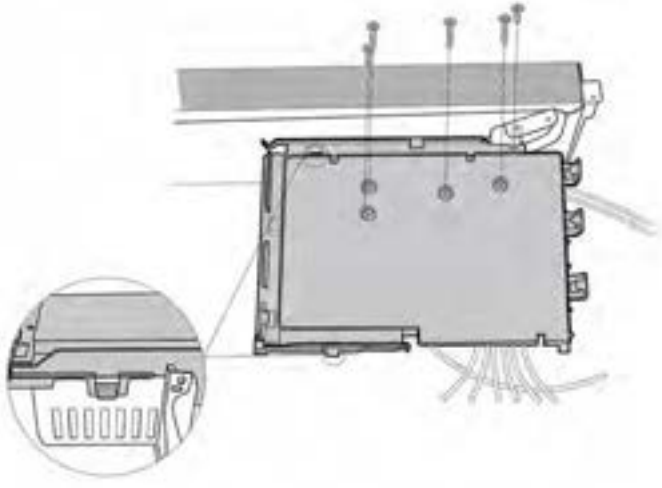
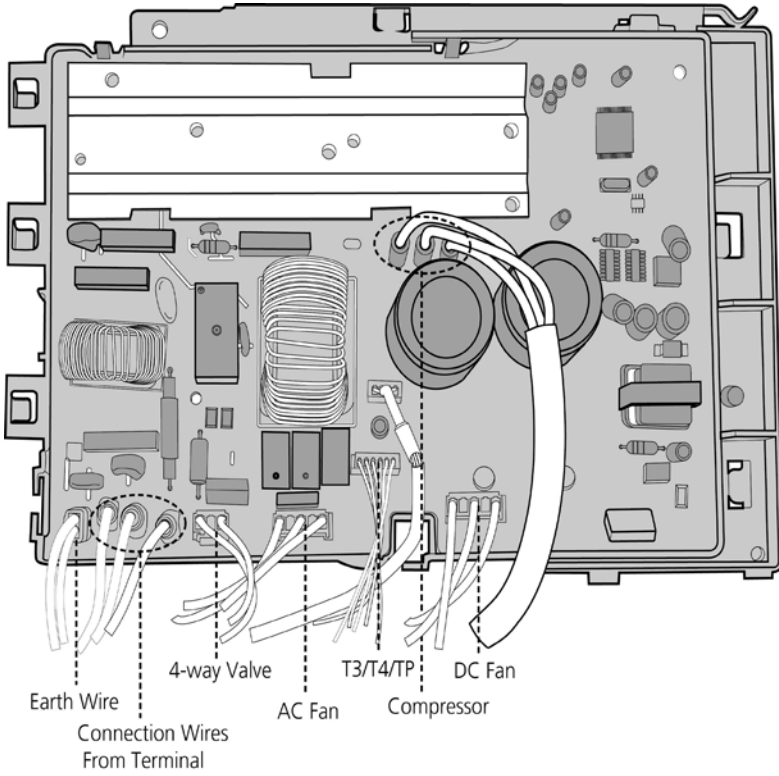
Procedure	Illustration
<p>1) Remove the screws and unfix the hooks, then open the electronic control box cover (5 screws and 2 hooks)(see CJ_ODU_PCB_003-1).</p> <p>Note: Electric control box cover cannot be removed, so the voltage between P and N cannot be measured.</p> <p>2) Remove all of connectors (see Fig CJ_ODU_PCB_003-2).</p> <p>3) Then remove the electronic control box subassembly.</p> <p>Note: When replacing the electronic control box subassembly with a new one, pay attention to applying thermal paste on the heat sink.</p>	 <p style="text-align: center;">CJ_ODU_PCB_003-1</p>  <p style="text-align: center;">CJ_ODU_PCB_003-2</p>

Note: This section is for reference only. Actual unit appearance may vary.

4. PCB board 4

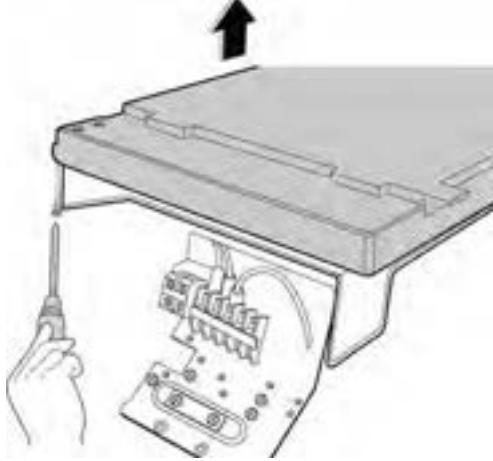
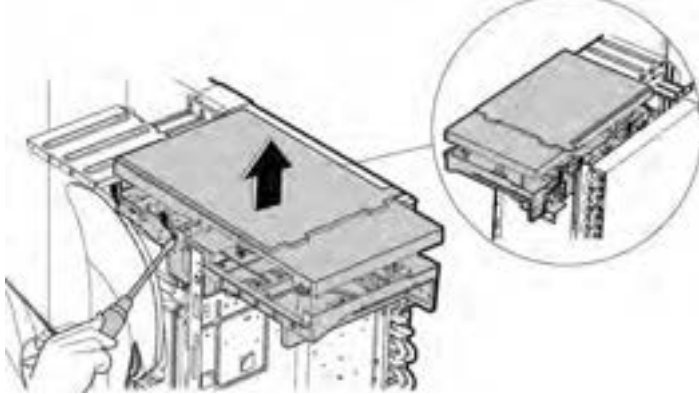
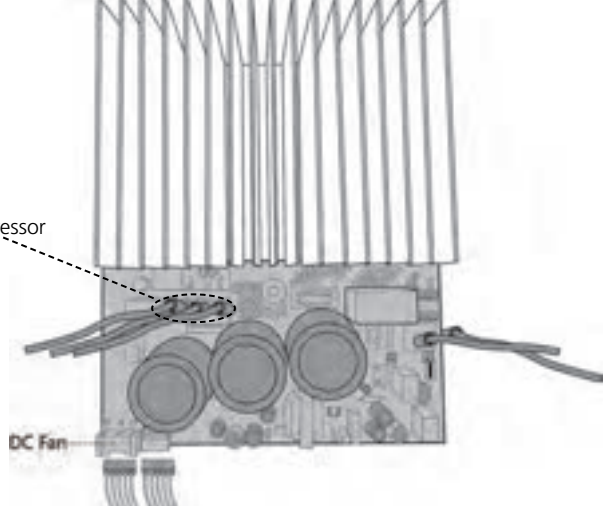
Procedure	Illustration
1) Remove the screws of the top cover. (1 screws) (see CJ_ODU_PCB_004-1).	 <p style="text-align: center;">CJ_ODU_PCB_004-1</p>
2) Unfix the hooks and then open the electronic control box cover (5 hooks) (see CJ_ODU_PCB_004-2).	 <p style="text-align: center;">CJ_ODU_PCB_004-2</p>
3) Disconnect the connector for fan motor from the IPM board (see CJ_ODU_PCB_004-3). 4) Remove the connector for the compressor (see CJ_ODU_PCB_004-3).	 <p style="text-align: center;">CJ_ODU_PCB_004-3</p>

Note: This section is for reference only. Actual unit appearance may vary.

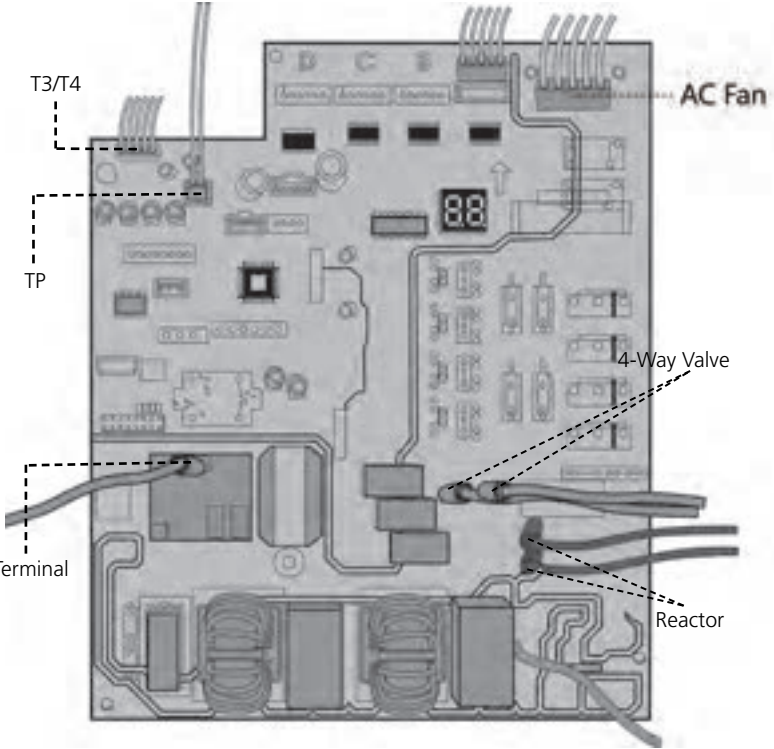
Procedure	Illustration
<p>5) Pull out the wire connected with the terminal. (see CJ_ODU_PCB_004-4).</p> <p>6) Pull out connectors of the condenser coil temp. sensor(T3),outdoor ambient temp. sensor(T4) and discharge temp. sensor(TP) (see CJ_ODU_PCB_004-4).</p> <p>7) Disconnect the electronic expansion valve wire (see Fig CJ_ODU_PCB_004-4).</p> <p>8) Remove the connector for 4-way valve. (see Fig CJ_ODU_PCB_004-4).</p> <p>9) Remove the connector for the reactor (see Fig CJ_ODU_PCB_004-4).</p> <p>10)Then remove the electronic control box (see Fig CJ_ODU_PCB_004-4).</p>	 <p style="text-align: center;">CJ_ODU_PCB_004-4</p>

Note: This section is for reference only. Actual unit appearance may vary.

5. PCB board 5

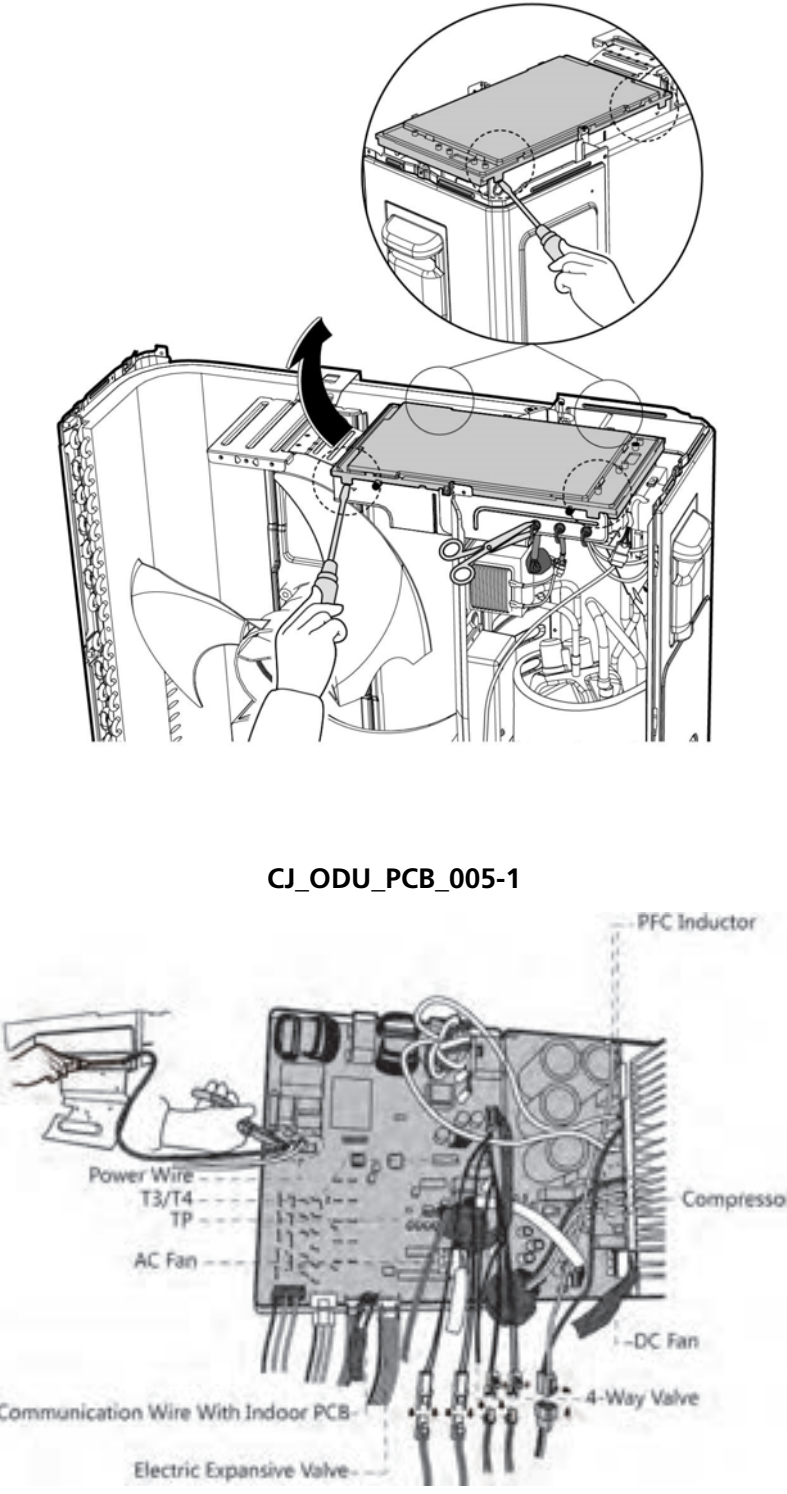
Procedure	Illustration
<ol style="list-style-type: none"> 1) Unfix the hooks and then open the electronic control box cover (4 hooks) (see CJ_ODU_PCB_005-1). 2) Disconnect the connector for outdoor DC fan from the electronic control board (see CJ_ODU_PCB_005-2). 3) Remove the connector for the compressor (see CJ_ODU_PCB_005-2). 4) Pull out the two blue wires connected with the four way valve (see CJ_ODU_PCB_005-2). 5) Pull out connectors of the condenser coil temp. sensor(T3), outdoor ambient temp. sensor(T4) and discharge temp. sensor(TP) (see CJ_ODU_PCB_005-2). 6) Disconnect the electronic expansion valve wire (see Fig CJ_ODU_PCB_005-2). 7) Disconnect the communication wire indoor PCB (see Fig CJ_ODU_PCB_005-2). 8) Disconnect the PFC inductor (see Fig CJ_ODU_PCB_005-2). 9) Then remove the electronic control box (see CJ_ODU_PCB_005-2). 	 <p style="text-align: center;">CJ_ODU_PCB_005-1</p> <p style="text-align: center;">CJ_ODU_PCB_005-2</p>

Note: This section is for reference only. Actual unit appearance may vary.

6. PCB board 6

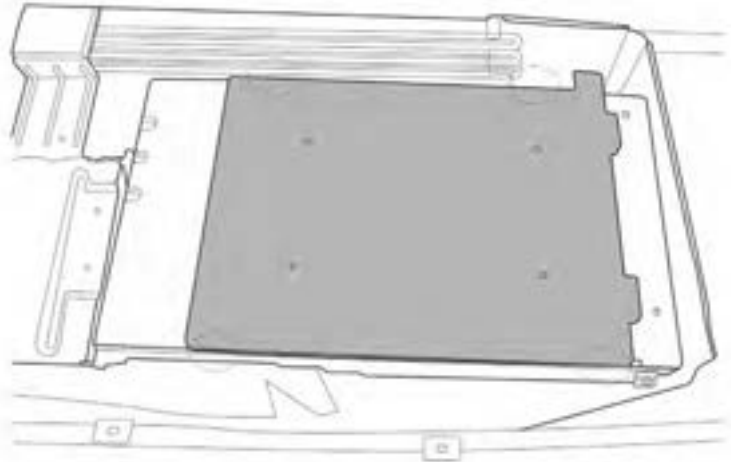
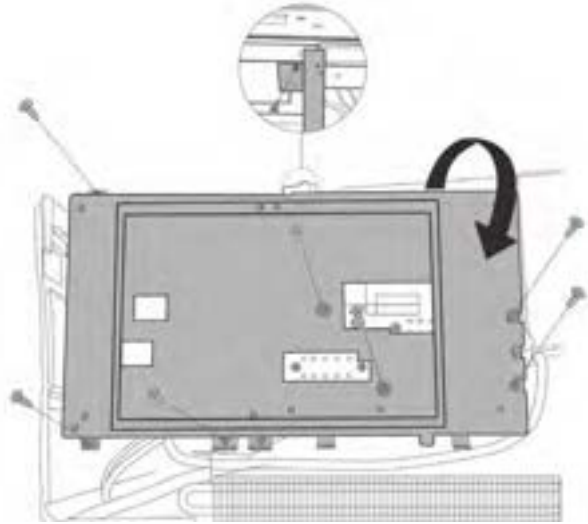
Procedure	Illustration
<p>1) Unfix the hooks and then open the electronic control box cover (4 hooks) (see CJ_ODU_PCB_006-1).</p> <p>2) Remove 8 screws on the electronic control board and then turn over the electronic control board (see CJ_ODU_PCB_006-2).</p> <p>Note: Electric control box cover cannot be removed, so the voltage between P and N cannot be measured.</p>	 <p data-bbox="879 965 1134 994">CJ_ODU_PCB_006-1</p>  <p data-bbox="879 1619 1134 1648">CJ_ODU_PCB_006-2</p>

Note: This section is for reference only. Actual unit appearance may vary.

Procedure	Illustration
<p>3) Pull out the two blue wires connected with the four way valve. (see CJ_ODU_PCB_006-3)(for heat pump models)</p> <p>4) Pull out connectors of the condenser coil temp. sensor(T3),outdoor ambient temp. sensor(T4) and discharge temp. sensor(TP). (see CJ_ODU_PCB_006-3)</p> <p>5) Disconnect the electronic expansion valve wire. (see Fig CJ_ODU_PCB_006-3)(for some models)</p> <p>6) Remove four screws and unfix the 3 hooks and then remove the main control board. (see CJ_ODU_PCB_006-3)</p> <p>7) Disconnect the connector for outdoor DC fan from the IPM board. (see CJ_ODU_PCB_006-3)(for some models)</p> <p>8) Remove the connector for the compressor. (see CJ_ODU_PCB_006-3)</p> <p>9) Remove the connector for the PFC Inductor. (see CJ_ODU_PCB_006-3)</p> <p>10)Pull out 3 connectors between IPM board and main control board.(see CJ_ODU_PCB_006-3)</p> <p>11)Remove two screws and unfix the 4 hooks and then remove the IPM board. (see CJ_ODU_PCB_006-3)</p> <p>Note: When replacing the IPM board with a new one, pay attention to applying thermal paste on the heat sink.</p>	<p style="text-align: center;">CJ_ODU_PCB_006-3</p>

Note: This section is for reference only. Actual unit appearance may vary.

7. PCB board 7

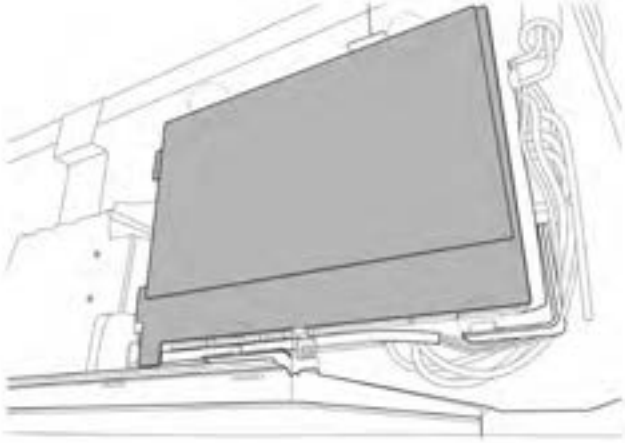
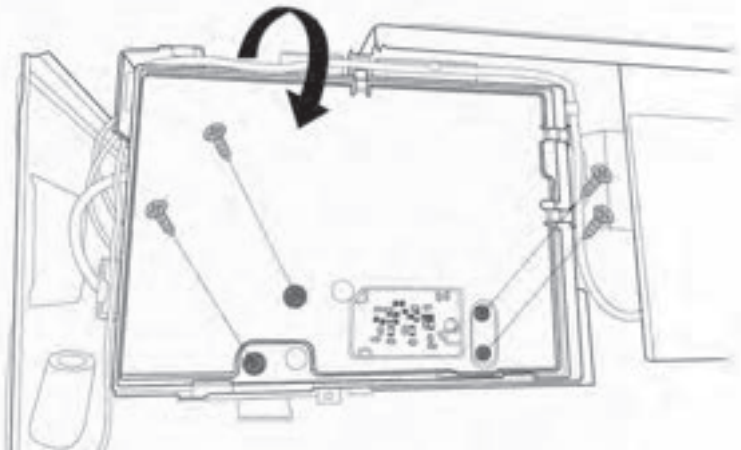
Procedure	Illustration
<p>1) Unfix the hooks and then open the electronic control box cover (4 hooks) (see CJ_ODU_PCB_007-1).</p>	 <p>CJ_ODU_PCB_007-1</p>
<p>2) Remove 4 screws on the electronic control board and then remove the electronic control box subassembly. (see CJ_ODU_PCB_007-2).</p> <p>Note: Electronic installing box cannot be opened, so the voltage between P and N cannot be measured.</p>	 <p>CJ_ODU_PCB_007-2</p>

Note: This section is for reference only. Actual unit appearance may vary.

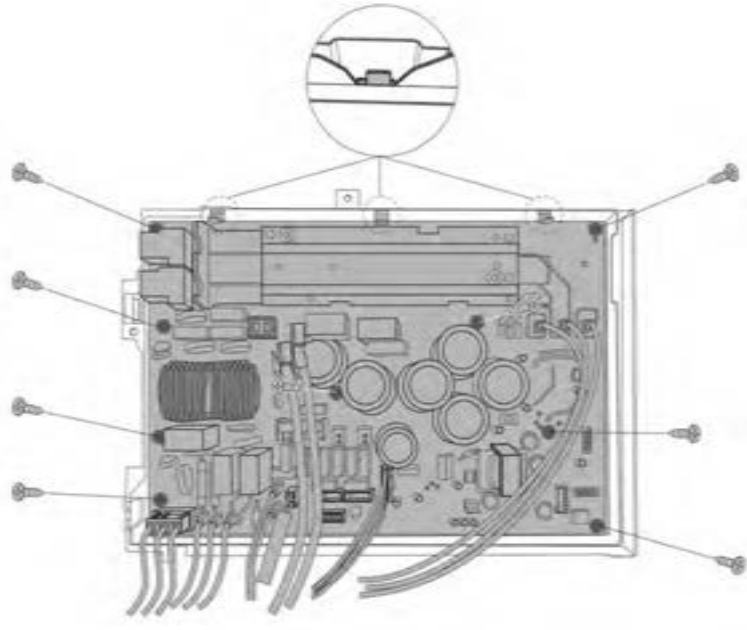
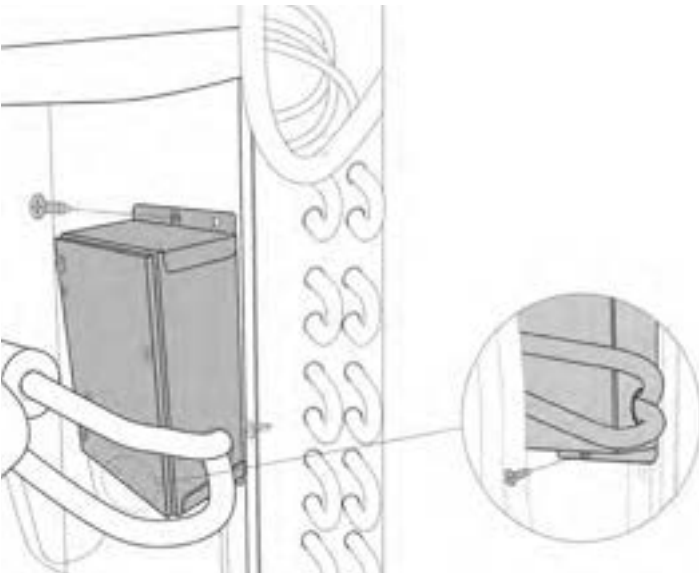
Procedure	Illustration
<p>3) Pull out the connectors (see CJ_ODU_PCB_007-3).</p> <p>4) Remove the 9 screws and unfix the 3 hooks and then remove the electronic control board(see CJ_ODU_PCB_007-3).</p>	 <p style="text-align: center;">CJ_ODU_PCB_007-3</p>
<p>5) Remove two screws and then remove the electronic control box subassembly on partition board assembly. (see CJ_ODU_PCB_007-4).</p>	 <p style="text-align: center;">CJ_ODU_PCB_007-4</p>

Note: This section is for reference only. Actual unit appearance may vary.

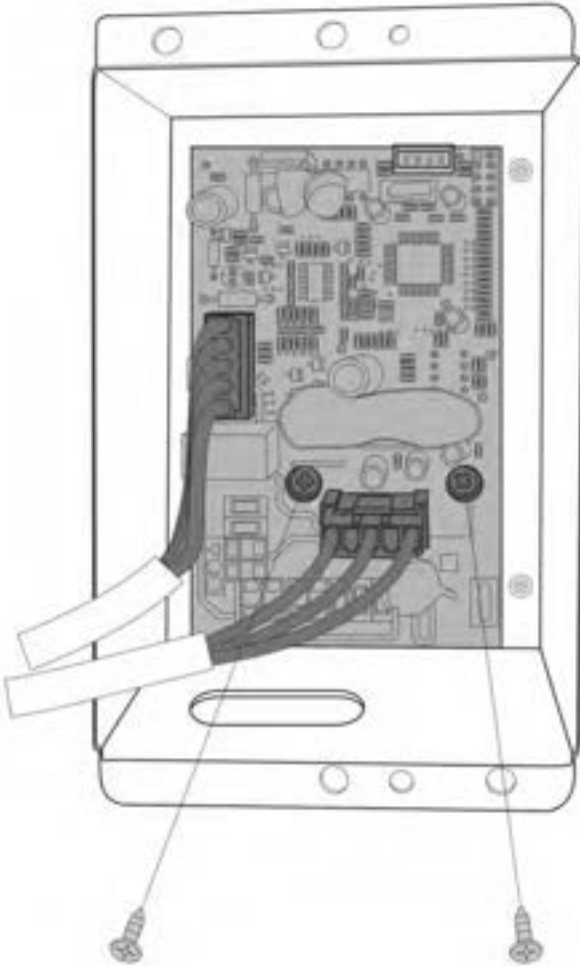
Procedure	Illustration
<p>6) Remove two screws and two connectors and then remove the inverter control board (see CJ_ODU_PCB_007-5).</p>	 <p data-bbox="877 1377 1141 1422">CJ_ODU_PCB_007-5</p>

Note: This section is for reference only. Actual unit appearance may vary.

8. PCB board 8

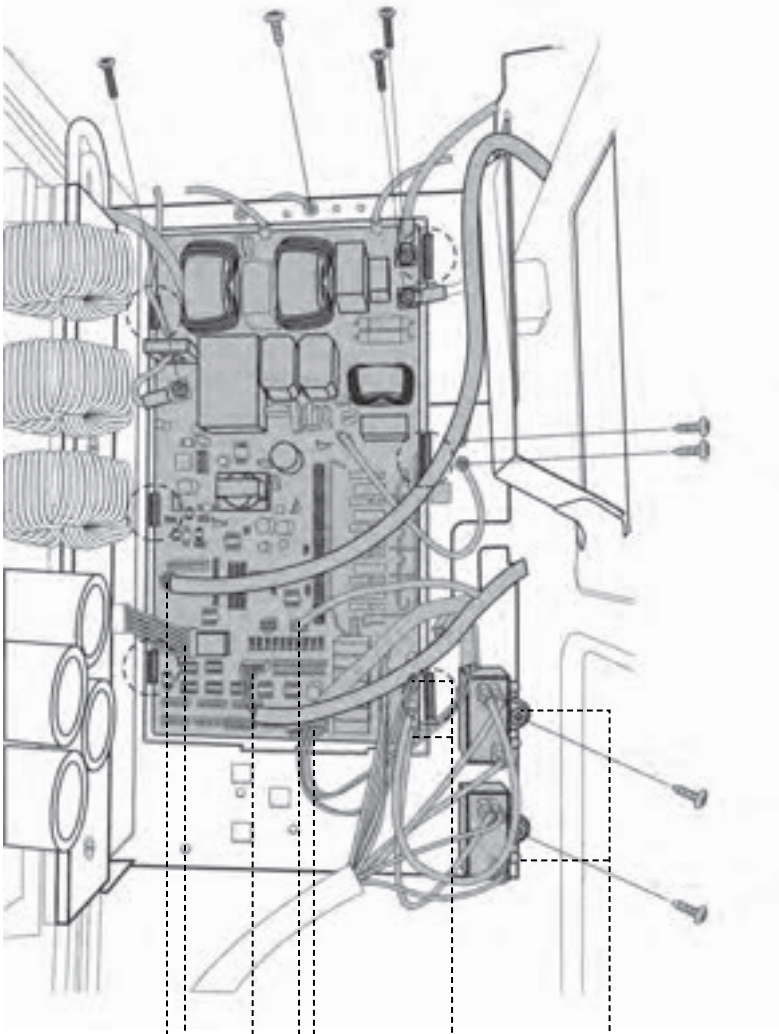
Procedure	Illustration
<ol style="list-style-type: none">1) Remove 2 screws to disconnect the power supply wires. (see CJ_ODU_PCB_008-1)2) Remove 3 screws to disconnect ground wires. (see CJ_ODU_PCB_008-1)3) Disconnect the wires connected to main control board. (see CJ_ODU_PCB_008-1)4) Disconnect the wires between main control board and IPM module board. (see CJ_ODU_PCB_008-1)5) Remove the 4 screws and unfix the 6 hooks and then remove the main control board. (see CJ_ODU_PCB_008-1)6) Remove 1 screw to remove the fan motor capacitor (1 screw for each capacitor). (see CJ_ODU_PCB_008-1).	 <p>The illustration shows a detailed view of the PCB board 8 assembly. It features a main control board at the top, an IPM module board below it, and two AC fan motors at the bottom. Various wires and components are labeled with dashed lines pointing to their locations. The labels include: 'connect to indoor unit' (pointing to a terminal block on the left), 'connect to IPM' (pointing to a terminal block on the left), 'T3&T4 TP' (pointing to a terminal block on the left), 'low&high pressure switch' (pointing to a component on the right), 'AC Fan motors' (pointing to the two fan motors at the bottom), and 'Fan motor capacitors' (pointing to two capacitors on the right). The entire illustration is titled 'CJ_ODU_PCB_008-1' at the bottom.</p>

Note: This section is for reference only. Actual unit appearance may vary.

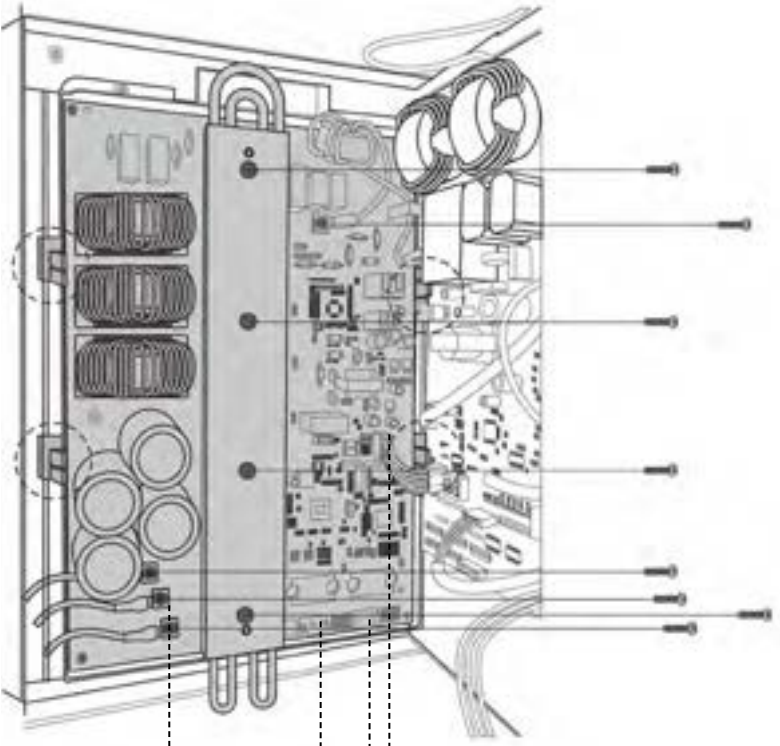
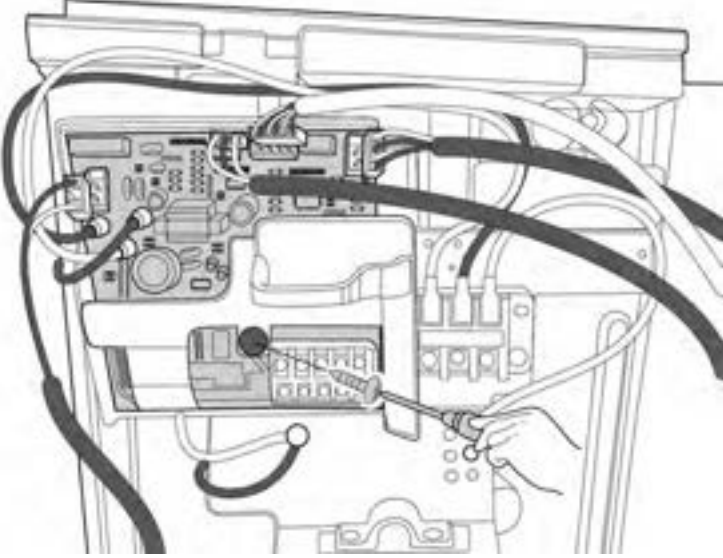
Procedure	Illustration
<ol style="list-style-type: none"> 1) Remove 2 screws to disconnect the power supply wires. (see CJ_ODU_PCB_008-2) 2) Remove 3 screws to disconnect the wires connected to the compressor. (see CJ_ODU_PCB_008-2) 3) Remove 3 screws to remove the radiator.(see CJ_ODU_PCB_008-2) 4) Disconnect the wires between IPM module board and main control board. (see CJ_ODU_PCB_008-2) 5) Remove the 4 screws and unfix the 4 hooks and then remove the IPM moduel board.(see CJ_ODU_PCB_008-2) 	 <p data-bbox="715 1066 1136 1128">Compressor DC Fan motors connect to main control board</p> <p data-bbox="879 1160 1136 1189">CJ_ODU_PCB_008-2</p>
<ol style="list-style-type: none"> 6) Remove the 1 screw and disconnect the wires and then remove the 24V board.(see CJ_ODU_PCB_008-3)(for some models) 	 <p data-bbox="759 1839 1257 1868">CJ_ODU_PCB_008-3(for some models)</p>

Note: This section is for reference only. Actual unit appearance may vary.

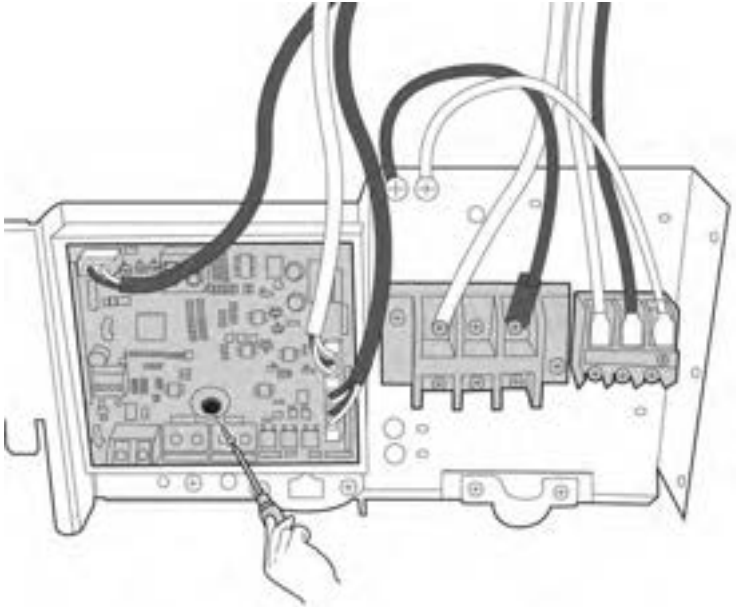
Procedure	Illustration
<p>1) Remove the 1 screw and disconnect the wires and then remove the key board.(see CJ_ODU_PCB_008-4)(for some models)</p>	 <p style="text-align: center;">CJ_ODU_PCB_008-4(for some models)</p>

Note: This section is for reference only. Actual unit appearance may vary.

9. PCB board 9

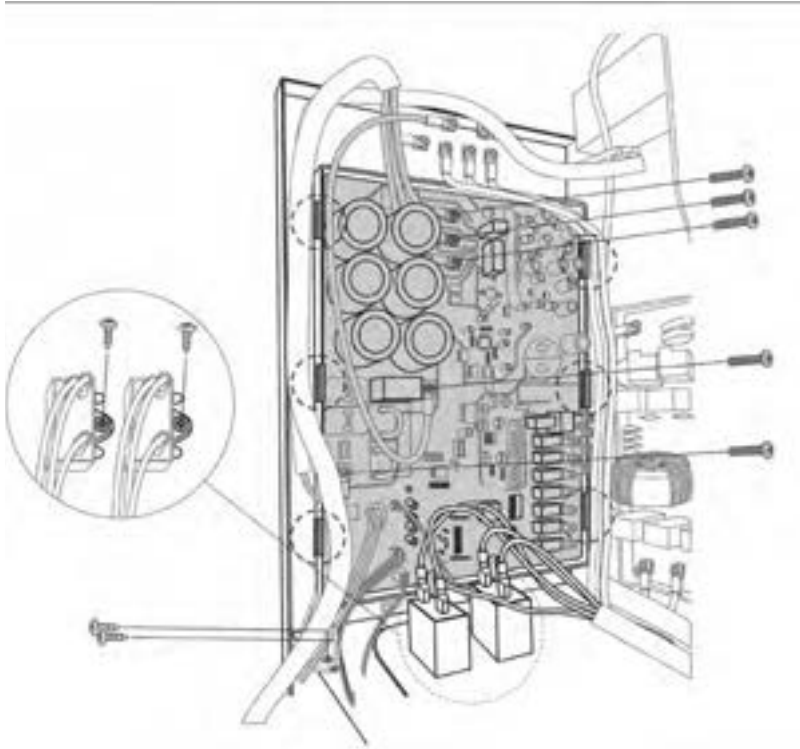
Procedure	Illustration
<p>2) Remove 3 screws to disconnect the wires connected to the compressor. (see CJ_ODU_PCB_009-1)</p> <p>3) Remove 2 screws to disconnect the power supply wires. (see CJ_ODU_PCB_009-1)</p> <p>4) Disconnect the wires connected to main control board. (see CJ_ODU_PCB_009-1)</p> <p>5) Remove the 4 screws and unfix the 6 hooks and then remove the main control board.(see CJ_ODU_PCB_009-1)</p> <p>6) Remove the screw of the fan capacitor and then remove it (1 screw for each capacitor). (see CJ_ODU_PCB_009-1)</p>	 <p style="text-align: center;">CJ_ODU_PCB_009-1</p>

Note: This section is for reference only. Actual unit appearance may vary.

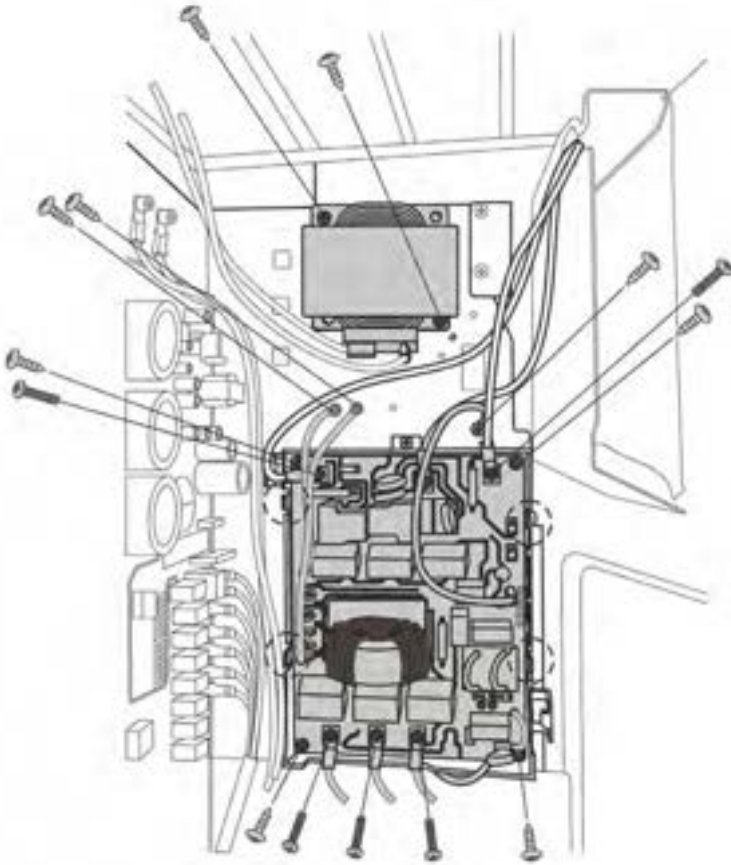
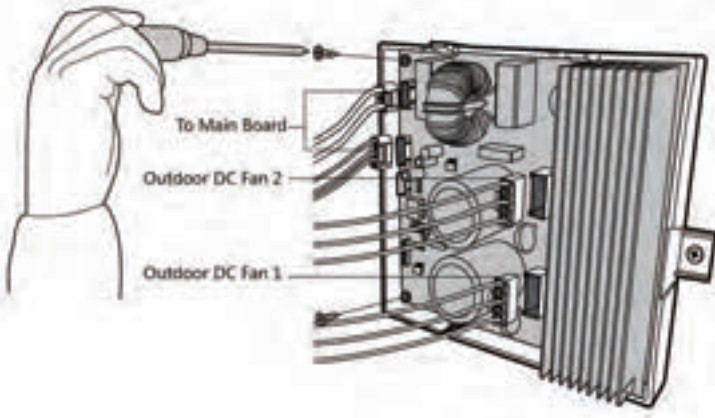
Procedure	Illustration
<p>7) Remove 3 screws to disconnect the power supply wires. (see CJ_ODU_PCB_009-1)</p> <p>8) Remove 3 screws to disconnect ground wires. (see CJ_ODU_PCB_009-1)</p> <p>9) Disconnect the wires connected to main control board. (see CJ_ODU_PCB_009-2)</p> <p>10) Remove the 4 screws and unfix the 4 hooks and then remove the filter board. (see CJ_ODU_PCB_009-2)</p> <p>11) Remove the 2 screws of the reactor and then remove it. (see CJ_ODU_PCB_009-2)</p>	 <p>A detailed technical drawing of the outdoor unit's internal PCB assembly. It shows a central control board with various components like capacitors, resistors, and connectors. Wires are shown connecting different parts of the board. Several screws are indicated with lines pointing to their locations on the board, corresponding to the steps in the procedure.</p>
<p>12) Disconnect the wires connected to main control board. (see CJ_ODU_PCB_009-3) (for some models)</p> <p>13) Remove the 2 screws and then remove the DC motor driver board. (see CJ_ODU_PCB_009-3) (for some models)</p>	<p style="text-align: center;">CJ_ODU_PCB_009-2</p>  <p>A close-up diagram showing a hand using a screwdriver to remove screws from a component. The component is labeled as the DC motor driver board. Wires are shown connected to the board, with labels: 'To Main Board', 'Outdoor DC Fan 2', and 'Outdoor DC Fan 1'. The board is mounted on a metal chassis.</p> <p style="text-align: center;">CJ_ODU_PCB_009-3 (for some models)</p>

Note: This section is for reference only. Actual unit appearance may vary.

10. PCB board 10

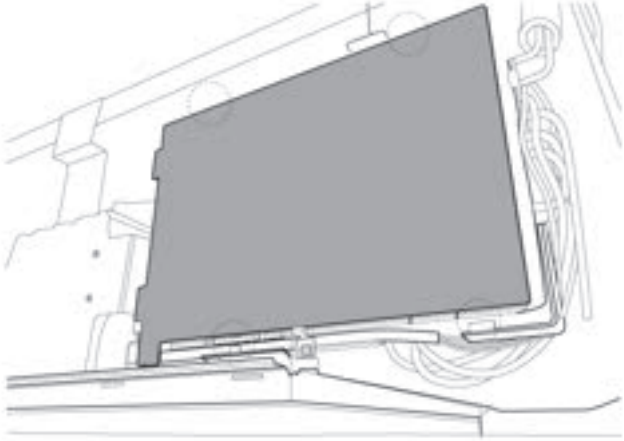
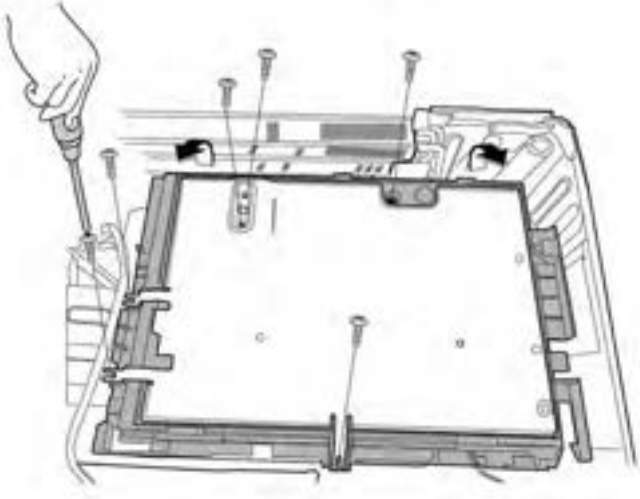
Procedure	Illustration
<p>1) Unfix the hooks and then open the electronic control box cover (4 hooks) (see CJ_ODU_PCB_010-1).</p> <p>2) Remove 6 screws on the electronic control board and then remove the electronic control box subassembly. (see CJ_ODU_PCB_010-2).</p> <p>Note: Electronic installing box cannot be opened, so the voltage between P and N cannot be measured.</p>	 <p data-bbox="879 958 1134 992">CJ_ODU_PCB_010-1</p>  <p data-bbox="879 1563 1134 1597">CJ_ODU_PCB_010-2</p>

Note: This section is for reference only. Actual unit appearance may vary.

11. PCB board 11

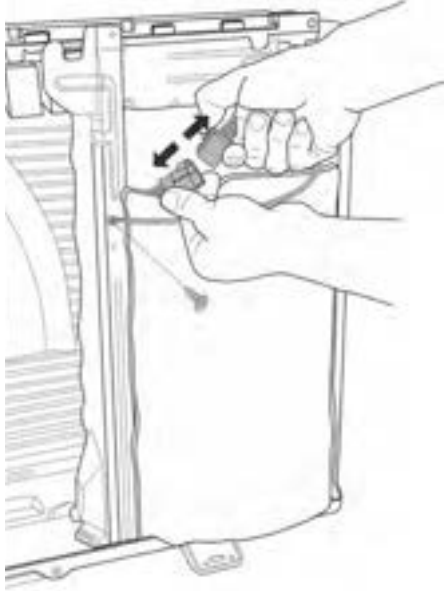
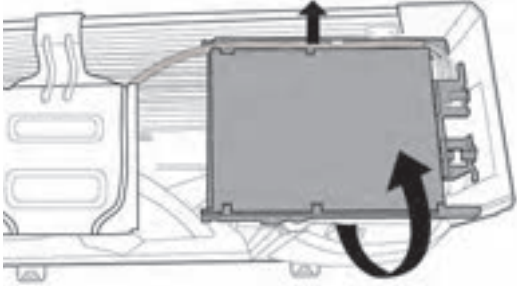
Procedure	Illustration
<p>1) Disconnect the connector for compressor and release the ground wire(1 screw). (see CJ_ODU_PCB_011-1).</p> <p>2) Remove the electronic control box subassembly. (see CJ_ODU_PCB_011-2).</p> <p>Note:Electric control box cover cannot be removed, so the voltage between P and N cannot be measured.</p>	 <p>CJ_ODU_PCB_011-1</p>  <p>CJ_ODU_PCB_011-2</p>

Note: This section is for reference only. Actual unit appearance may vary.

12. PCB board 12

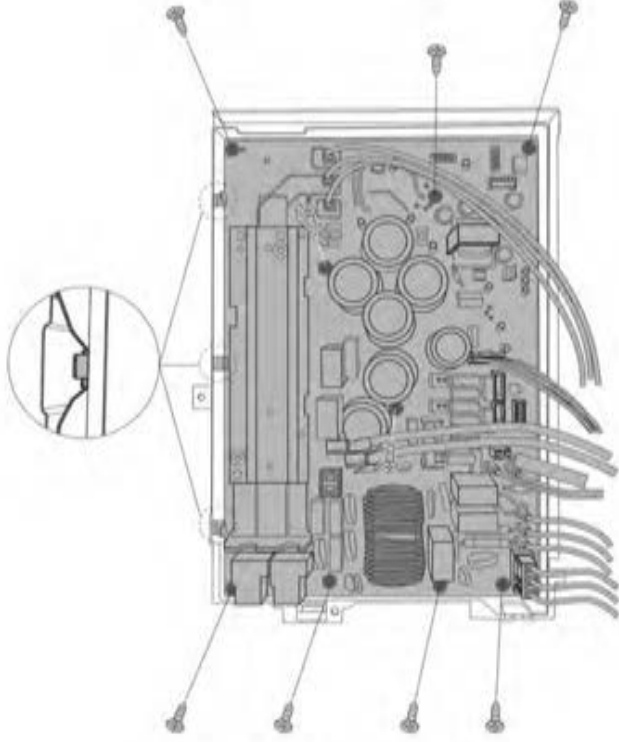
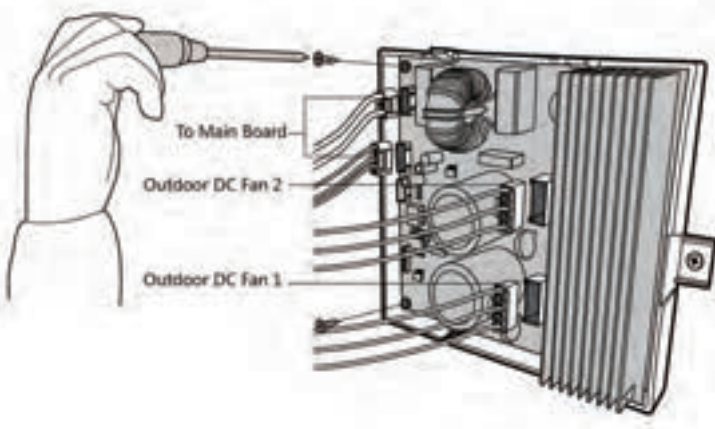
Procedure	Illustration
<p>1) Pull out the connectors (see CJ_ODU_PCB_012-1).</p> <p>2) Remove the 9 screws and unfix the 3 hooks and then remove the electronic control board(see CJ_ODU_PCB_012-2).</p>	 <p>The diagram shows the internal PCB board of the outdoor unit. Nine screws are indicated by lines pointing to their locations: three along the top edge and six along the bottom edge. Three hooks are also shown on the left side of the board. A circular inset provides a magnified view of one of the hooks.</p> <p style="text-align: center;">CJ_ODU_PCB_012-1</p>
<p>3) Disconnect the wires connected to main control board. (see CJ_ODU_PCB_012-2)(for some models)</p> <p>4) Remove the 2 screws and then remove the DC motor driver board. (see CJ_ODU_PCB_012-2)(for some models)</p>	 <p>The diagram illustrates the removal of the DC motor driver board. A hand is shown using a screwdriver to remove a screw from the board. Labels indicate the connections for 'To Main Board', 'Outdoor DC Fan 2', and 'Outdoor DC Fan 1'.</p> <p style="text-align: center;">CJ_ODU_PCB_012-2 (for some models)</p>

Note: This section is for reference only. Actual unit appearance may vary.

13. PCB board 13

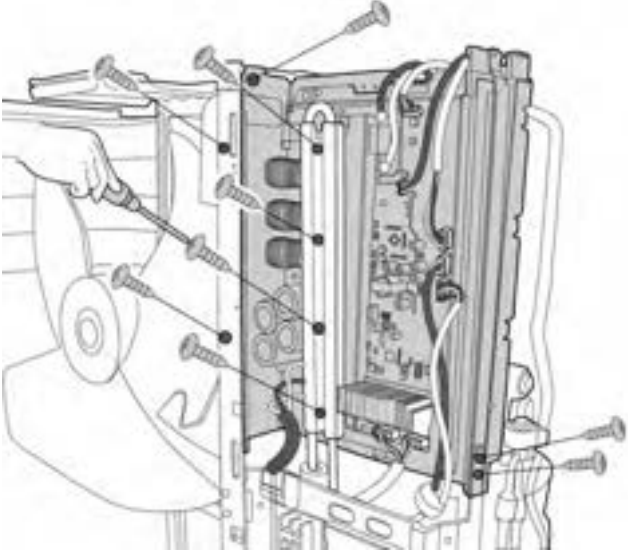
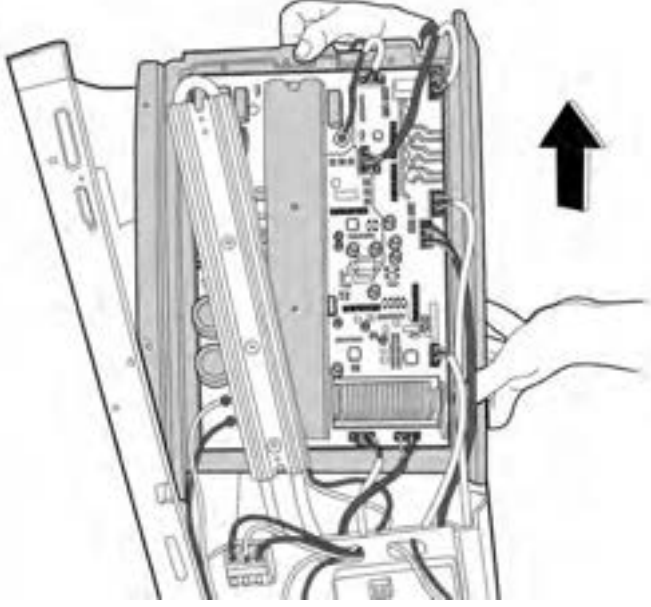
Procedure	Illustration
<p>1) Remove 4 screws unfix the radiator. (see CJ_ODU_PCB_013-1)</p> <p>2) Remove 3 screws unfix the electronic control box assembly and partition board. (see CJ_ODU_PCB_013-1)</p> <p>3) Remove 2 screws unfix the electronic control box assembly and terminal board subassembly. (see CJ_ODU_PCB_013-1)</p> <p>4) Move upward and slowly remove the electronic control box assembly. (CJ_ODU_PCB_013-2)</p> <p>(If you want to repair the electrical control box components, perform the steps 1 to 4; If you want to repair the main control board assembly, perform steps 5 to 7 below.)</p>	 <p style="text-align: center;">CJ_ODU_PCB_013-1</p>  <p style="text-align: center;">CJ_ODU_PCB_013-2</p>

Note: This section is for reference only. Actual unit appearance may vary.

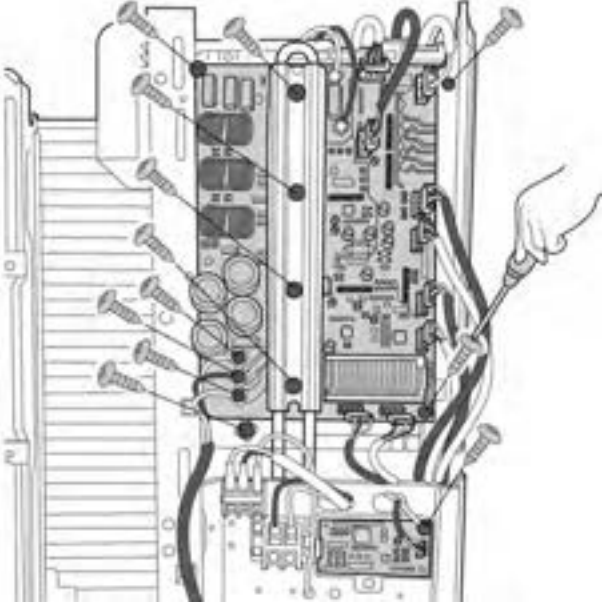
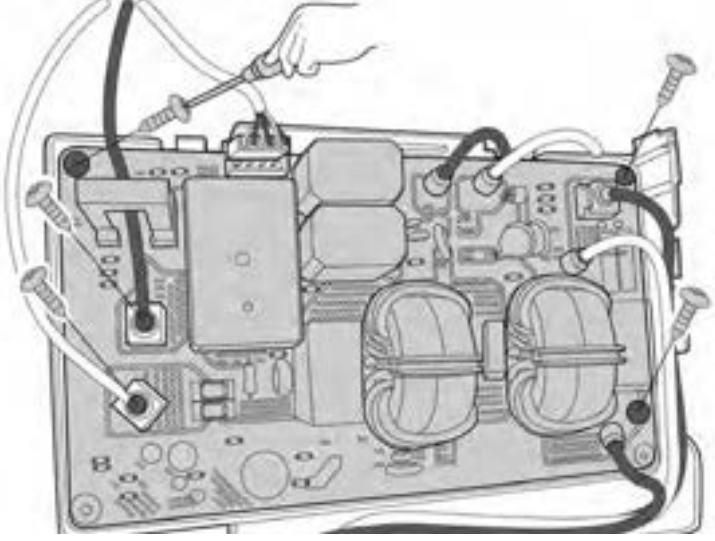
Procedure	Illustration
<p>5) Disconnect the wires connected to main control board. (see CJ_ODU_PCB_013-3)</p> <p>6) Remove the 4 screws and then remove the main control board.(see CJ_ODU_PCB_013-3)</p> <p>7) Remove 1 screw to remove the key board .(see CJ_ODU_PCB_013-3).</p>	 <p style="text-align: center;">CJ_ODU_PCB_013-3</p>
<p>8) Disconnect the wires between filter board and main control board. (see CJ_ODU_PCB_013-4)</p> <p>9) Remove the 3 screws and then remove the filter board.(see CJ_ODU_PCB_013-4) (Filter board is on the back of the electronic control box assembly)</p>	 <p style="text-align: center;">CJ_ODU_PCB_013-4</p>

Note: This section is for reference only. Actual unit appearance may vary.

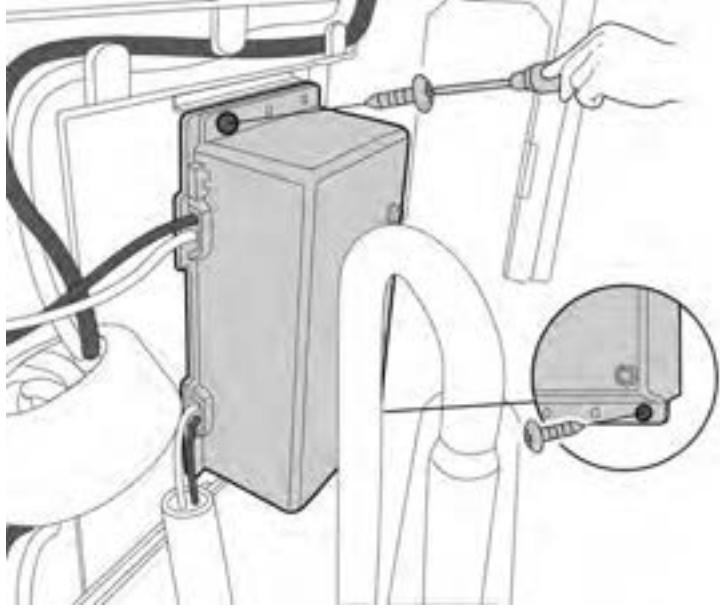
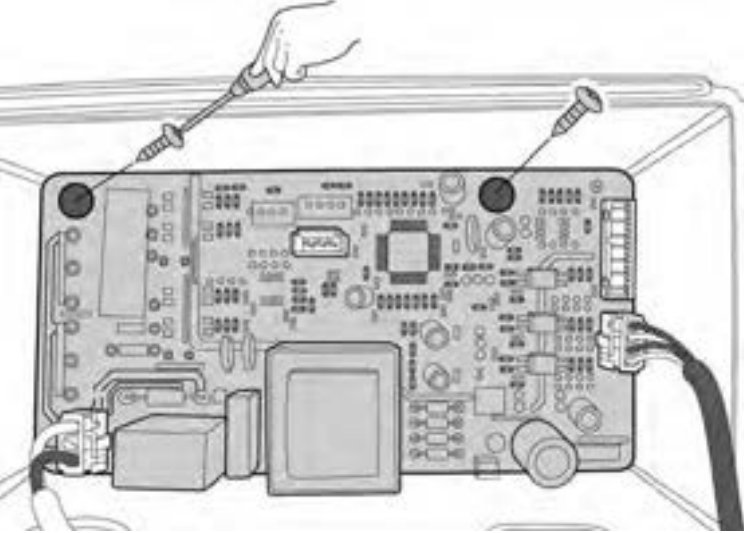
Procedure	Illustration
<p>10) Remove the 2 screws and then remove the DR module box subassembly. (see CJ_ODU_PCB_013-5) (DR module box subassembly is on the back of the electronic control box assembly) (for some models)</p>	 <p style="text-align: center;">CJ_ODU_PCB_013-5 (for some models)</p>
<p>11) Remove the 2 screws and then remove the DR module board. (see CJ_ODU_PCB_013-6) (for some models)</p>	 <p style="text-align: center;">CJ_ODU_PCB_013-6 (for some models)</p>

Note: This section is for reference only. Actual unit appearance may vary.

14. PCB board 14

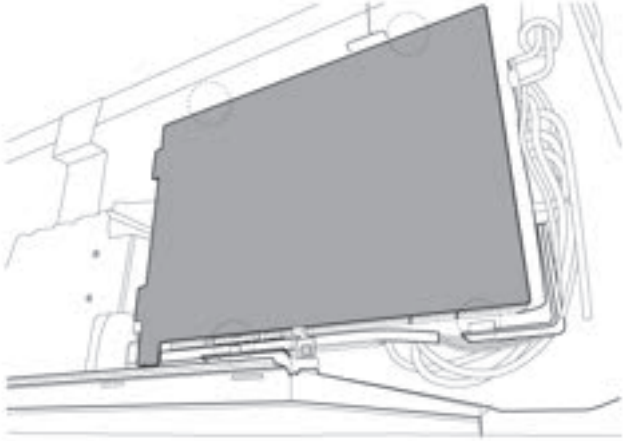
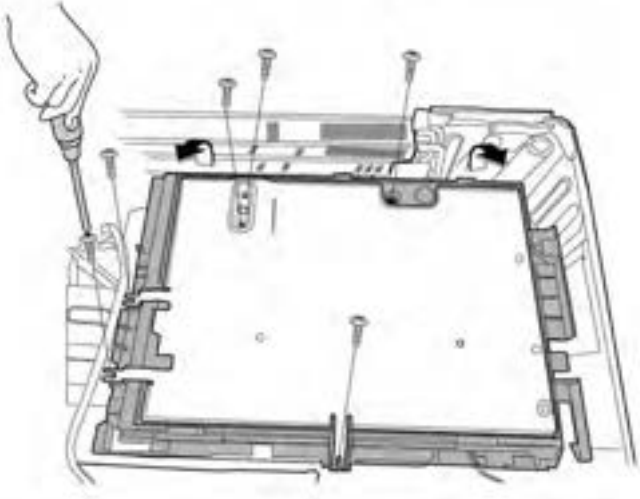
Procedure	Illustration
<p>1) Unfix the hooks and then open the electronic control box cover (4 hooks) (see CJ_ODU_PCB_014-1).</p> <p>2) Remove 6 screws on the electronic control board and then remove the electronic control box subassembly. (see CJ_ODU_PCB_014-2).</p> <p>Note: Electronic installing box cannot be opened, so the voltage between P and N cannot be measured.</p>	 <p style="text-align: center;">CJ_ODU_PCB_014-1</p>  <p style="text-align: center;">CJ_ODU_PCB_014-2</p>

Note: This section is for reference only. Actual unit appearance may vary.

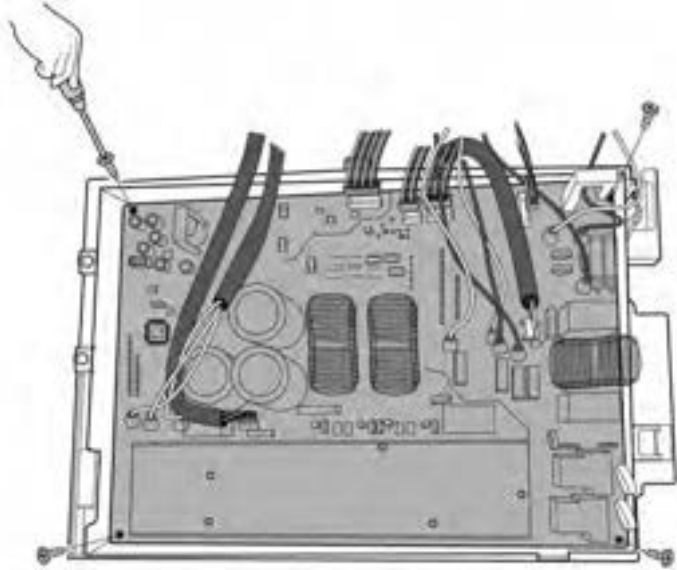
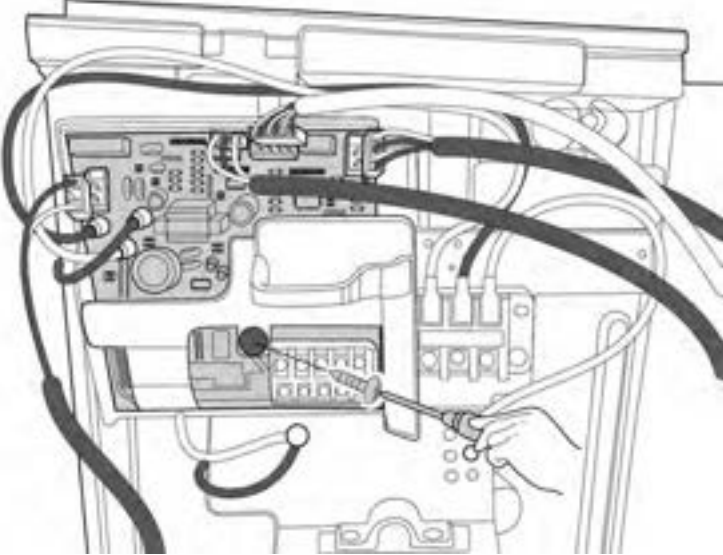
Procedure	Illustration
<p>3) Pull out the connectors (see CJ_ODU_PCB_014-3).</p> <p>4) Remove the 4 screws and then remove the electronic control board(see CJ_ODU_PCB_041-3).</p> <p>Note: When replacing the main control board with a new one, pay attention to applying thermal paste on the heat sink.</p>	 <p style="text-align: center;">CJ_ODU_PCB_014-3</p>
<p>5) Remove the 1 screw and disconnect the wires and then remove the 24V board.(see CJ_ODU_PCB_014-4)(for some models)</p>	 <p style="text-align: center;">CJ_ODU_PCB_014-4(for some models)</p>

Note: This section is for reference only. Actual unit appearance may vary.

15. PCB board 15

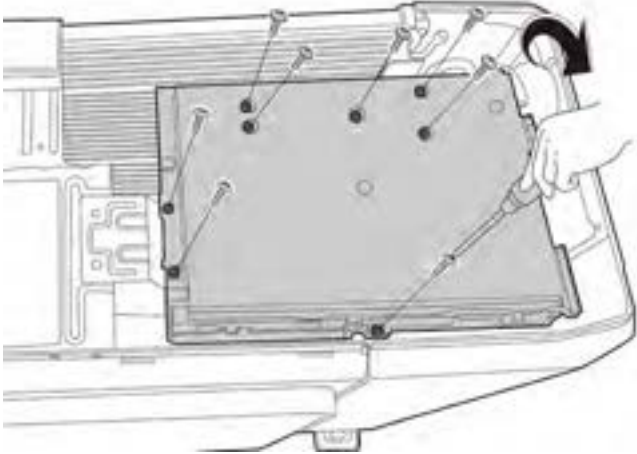
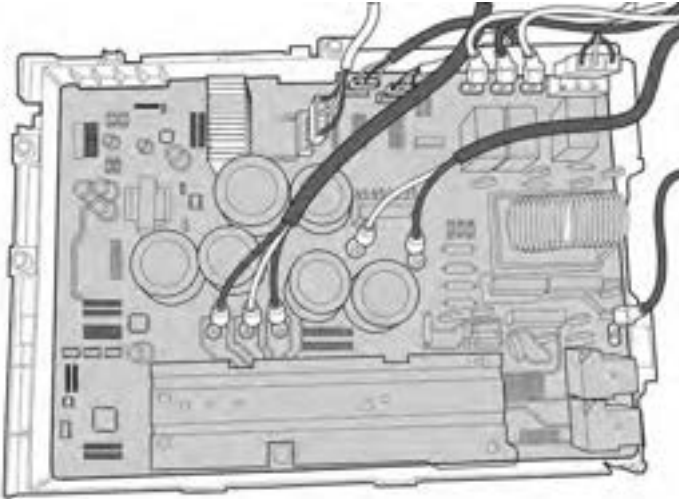
Procedure	Illustration
<p>1) Remove the screws and unfix the hooks, then open the electronic control box cover (7 screws)(see CJ_ODU_PCB_015-1).</p> <p>Note:Electric control box cover cannot be removed, so the voltage between P and N cannot be measured.</p>	 <p>The diagram shows a top-down view of the electronic control box cover. Seven screws are indicated by lines pointing to their locations. A hand is shown on the right side, pulling the cover away from the unit. A curved arrow indicates the direction of movement.</p> <p style="text-align: center;">CJ_ODU_PCB_015-1</p>
<p>2) Remove all of connectors (see Fig CJ_ODU_PCB_015-2).</p> <p>3) Unfix the 2 hooks and then remove the electronic control board.</p> <p>Note: When replacing the electronic control board with a new one, pay attention to applying thermal paste on the heat sink.</p>	 <p>The diagram shows the electronic control board with several connectors being removed. The board is populated with various components, including capacitors and integrated circuits. Wires are connected to the board, and the connectors are being unplugged.</p> <p style="text-align: center;">CJ_ODU_PCB_015-2</p>

Note: This section is for reference only. Actual unit appearance may vary.

16. PCB board 16

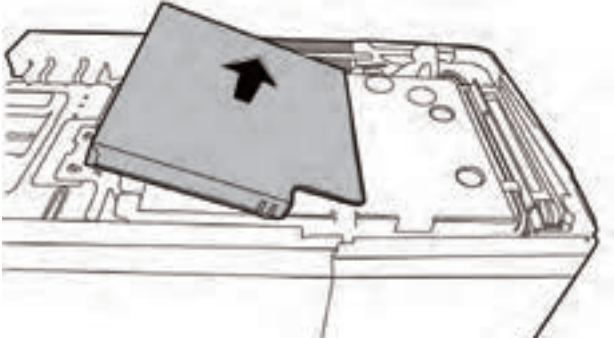
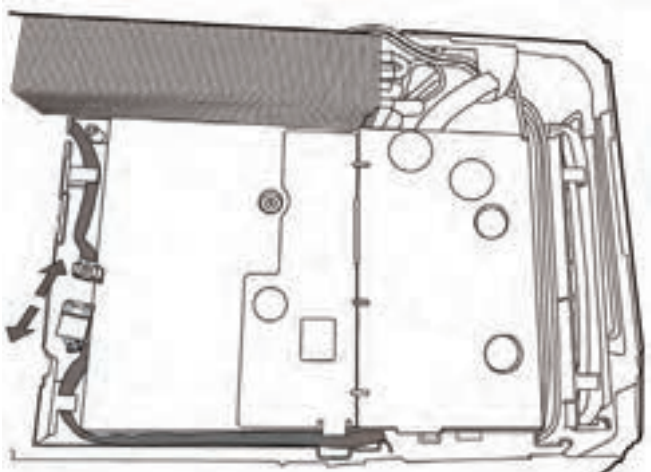
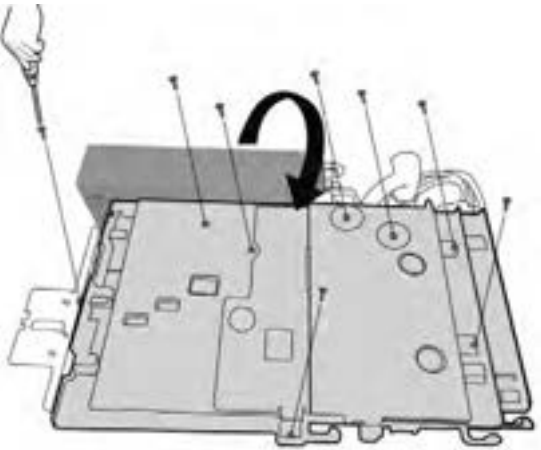
Procedure	Illustration
1) Remove the cover of electrical control box. (see CJ_ODU_PCB_016-1).	 <p>CJ_ODU_PCB_016-1</p>
2) Disconnect the fan motor connector. (see CJ_ODU_PCB_016-2).	 <p>CJ_ODU_PCB_016-2</p>
3) Remove eight fixing screws. 4) Turn over the electronic control box subassembly. (see CJ_ODU_PCB_016-3).	 <p>CJ_ODU_PCB_016-3</p>

Note: This section is for reference only. Actual unit appearance may vary.

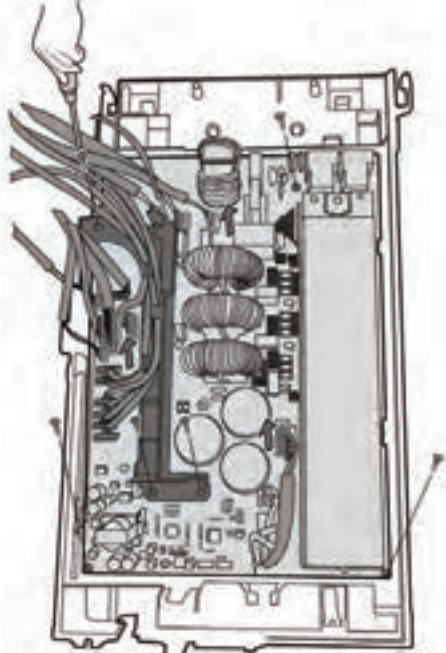
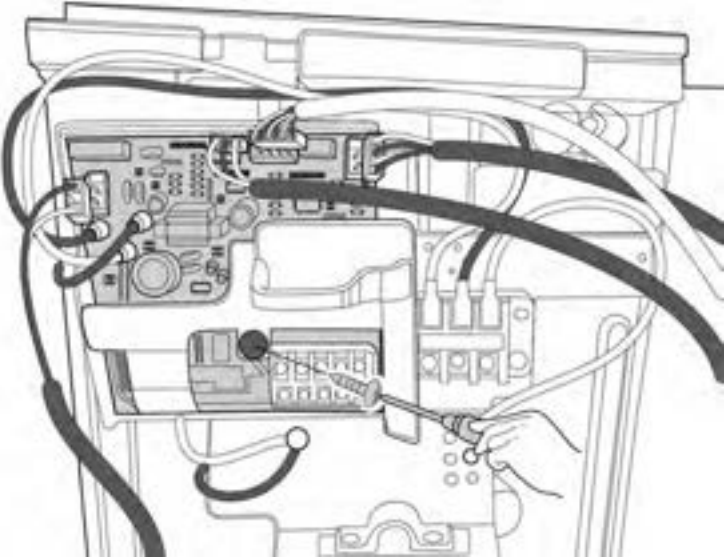
Procedure	Illustration
<p>5) Remove 3 screws and then remove the bracket. (see CJ_ODU_PCB_016-4).</p> <p>6) Disconnect the connectors from the electronic control board (see CJ_ODU_PCB_016-4).</p> <p>7) Remove 3 screws and then remove the electronic control board.(see CJ_ODU_PCB_016-4).</p>	 <p style="text-align: center;">CJ_ODU_PCB_016-4</p>
<p>8) Remove the 1 screw and disconnect the wires and then remove the 24V board.(see CJ_PCB_016-5).</p>	 <p style="text-align: center;">CJ_ODU_PCB_016-5</p>

Note: This section is for reference only. Actual unit appearance may vary.

2.3 Fan Assembly

Note: Remove the panel plate (refer to 3.1 Panel Plate) before disassembling fan.

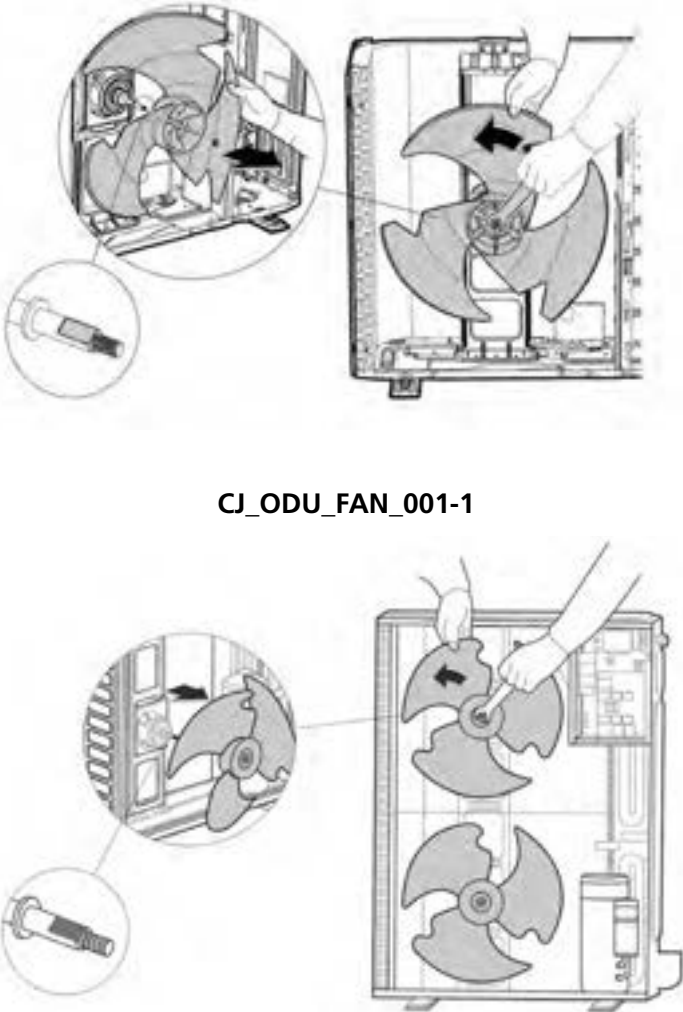
Procedure	Illustration
<p>1) Remove the nut securing the fan with a spanner (see CJ_ODU_FAN_001-1&2).</p> <p>2) Remove the fan.</p>	 <p data-bbox="874 1003 1136 1034">CJ_ODU_FAN_001-1</p> <p data-bbox="874 1572 1136 1603">CJ_ODU_FAN_001-2</p>

Note: This section is for reference only. Actual unit appearance may vary.

2.4 Fan Motor

Note: Remove the panel plate and the connection of fan motor on PCB (refer to 3.1 Panel Plate and 3.2 Electrical parts) before disassembling fan motor.

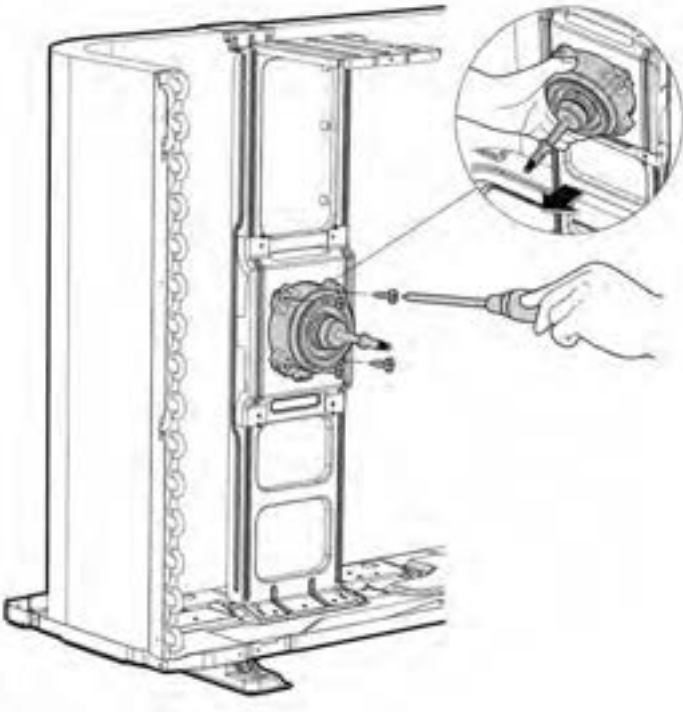
Procedure	Illustration
<p>3) Remove the fixing screws of the fan motor (4 screws) (see CJ_ODU_MOTOR_001).</p> <p>4) Remove the fan motor.</p>	 <p>The illustration shows a side view of an outdoor unit with its front panel removed. A hand is using a screwdriver to remove a screw from the fan motor. A circular inset provides a magnified view of the fan motor's mounting bracket and the screw being removed. The fan motor is mounted on a vertical support structure within the unit's chassis.</p> <p data-bbox="893 1232 1181 1265">CJ_ODU_MOTOR_001</p>

Note: This section is for reference only. Actual unit appearance may vary.

2.5 Sound blanket

Note: Remove the panel plate (refer to 3.1 Panel plate) before disassembling sound blanket.

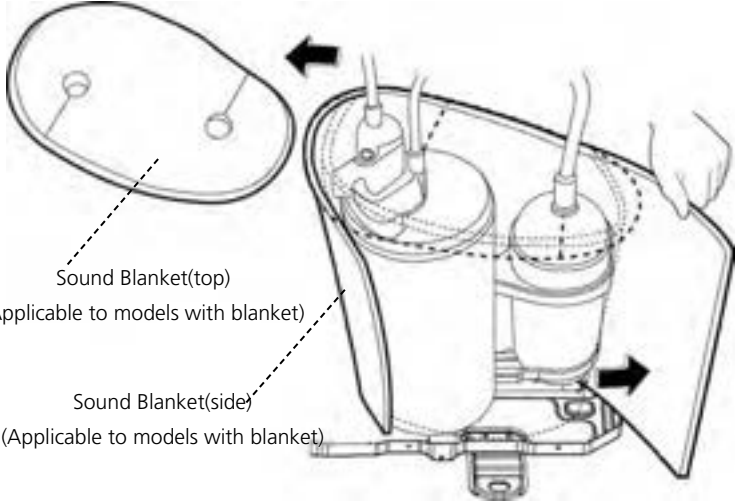
Procedure	Illustration
1) Remove the sound blanket (side and top) (see CJ_ODU_BLANKET_001).	 <p>Sound Blanket(top) (Applicable to models with blanket)</p> <p>Sound Blanket(side) (Applicable to models with blanket)</p> <p>CJ_ODU_BLANKET_001</p>

Note: This section is for reference only. Actual unit appearance may vary.

2.6 Four-way valve (for heat pump models)

⚠ WARNING: Evacuate the system and confirm that there is no refrigerant left in the system before removing the four-way valve and the compressor. (For R32 & R290, you should evacuate the system with the vacuum pump; flush the system with nitrogen; then repeat the two steps before heating up the brazed parts. The operations above should be implemented by professionals.)

Note: Remove the panel plate, connection of four-way valve on PCB (refer to 3.1 Panel plate and 3.2 Electrical parts) before disassembling sound blanket.

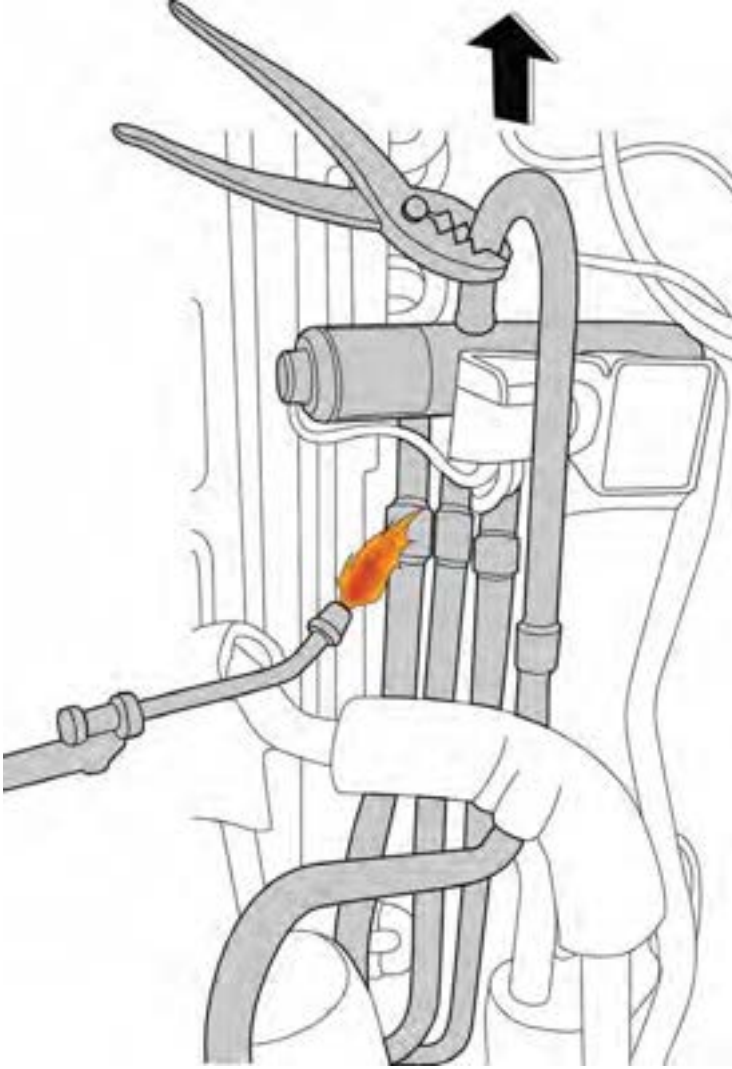
Procedure	Illustration
<ol style="list-style-type: none">1) Heat up the brazed parts and then detach the the four-way valve and the pipe (see CJ_ODU_VALVE_001).2) Remove the four-way valve assembly with pliers.	 <p data-bbox="906 1691 1173 1724">CJ_ODU_VALVE_001</p>

Note: This section is for reference only. Actual unit appearance may vary.

2.7 Compressor

⚠ WARNING: Evacuate the system and confirm that there is no refrigerant left in the system before removing the four-way valve and the compressor. (For R32 & R290, you should evacuate the system with the vacuum pump; flush the system with nitrogen; then repeat the two steps before heating up the brazed parts. The operations above should be implemented by professionals.)

Note: Remove the panel plate, connection of compressor on PCB (refer to 3.1 Panel plate and 3.2 Electrical parts) before disassembling sound blanket.

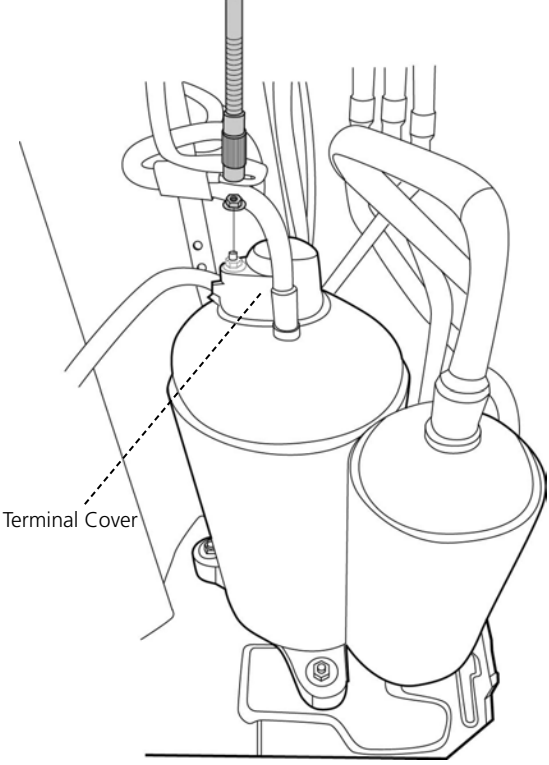
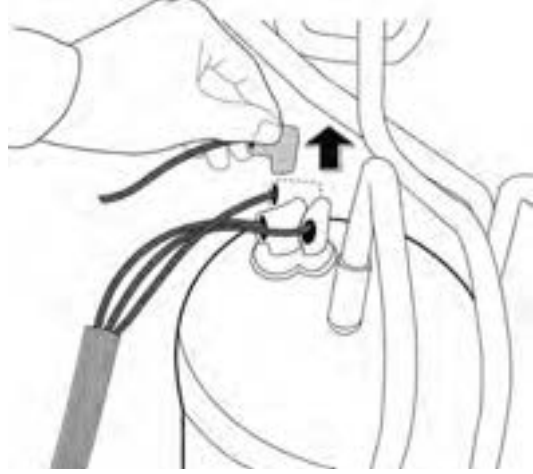
Procedure	Illustration
1) Remove the flange nut of terminal cover and remove the terminal cover (see CJ_ODU_COMP_001).	 <p>The diagram shows a top-down view of the compressor assembly. A dashed line points to a terminal cover on the left side of the unit. The cover is being lifted away from the compressor's terminal block.</p> <p style="text-align: center;">CJ_ODU_COMP_001</p>
2) Disconnect the connectors (see CJ_ODU_COMP_002).	 <p>The diagram shows a close-up of a hand disconnecting an electrical connector from the compressor's terminal block. An arrow points upwards, indicating the direction of the disconnection.</p> <p style="text-align: center;">CJ_ODU_COMP_002</p>

Note: This section is for reference only. Actual unit appearance may vary.

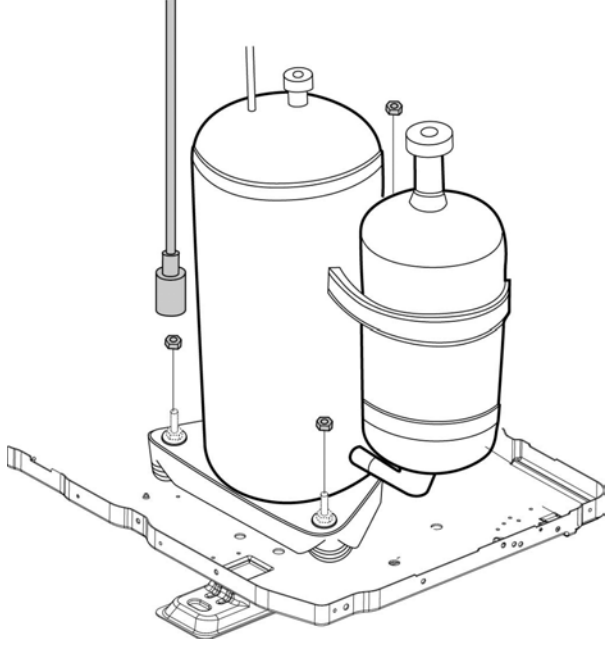
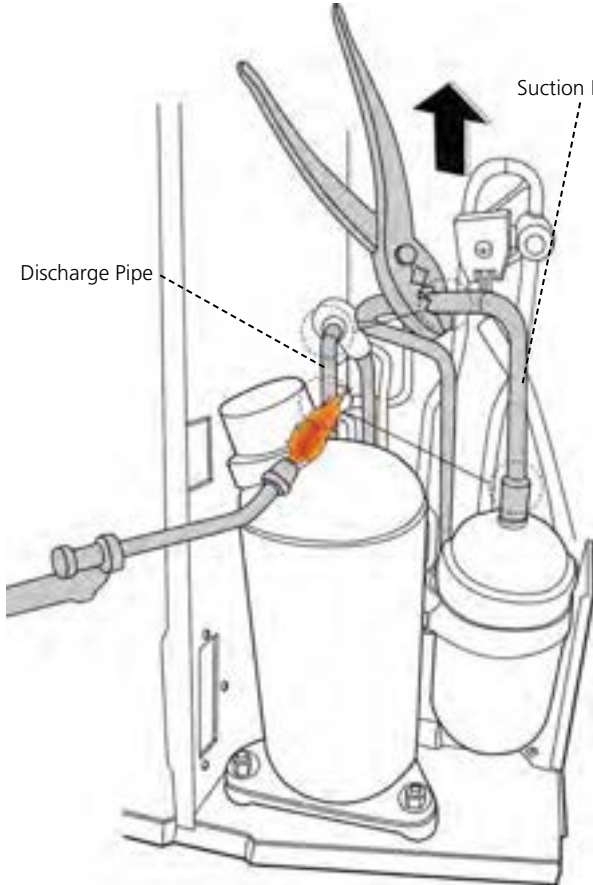
Procedure	Illustration
<p>3) Remove the hex nuts and washers securing the compressor, located on the bottom plate (see CJ_ODU_COMP_003).</p>	 <p style="text-align: center;">CJ_ODU_COMP_003</p>
<p>4) Heat up the brazed parts and then remove the the discharge pipe and the suction pipe (see CJ_ODU_COMP_004).</p> <p>5) Lift the compressor from the base pan assembly with pliers.</p>	 <p style="text-align: center;">CJ_ODU_COMP_004</p>

Note: This section is for reference only. Actual unit appearance may vary.

Appendix

Contents

i)	Temperature Sensor Resistance Value Table for T1, T2, T3, and T4 (°C – K)	2
ii)	Temperature Sensor Resistance Value Table for TP (for some units)(°C --K)	3
iii)	Pressure On Service Port	4

i) Temperature Sensor Resistance Value Table for T1,T2,T3 and T4 (°C – K)

°C	°F	K Ohm	°C	°F	K Ohm	°C	°F	K Ohm	°C	°F	K Ohm
-20	-4	115.266	20	68	12.6431	60	140	2.35774	100	212	0.62973
-19	-2	108.146	21	70	12.0561	61	142	2.27249	101	214	0.61148
-18	0	101.517	22	72	11.5	62	144	2.19073	102	216	0.59386
-17	1	96.3423	23	73	10.9731	63	145	2.11241	103	217	0.57683
-16	3	89.5865	24	75	10.4736	64	147	2.03732	104	219	0.56038
-15	5	84.219	25	77	10	65	149	1.96532	105	221	0.54448
-14	7	79.311	26	79	9.55074	66	151	1.89627	106	223	0.52912
-13	9	74.536	27	81	9.12445	67	153	1.83003	107	225	0.51426
-12	10	70.1698	28	82	8.71983	68	154	1.76647	108	226	0.49989
-11	12	66.0898	29	84	8.33566	69	156	1.70547	109	228	0.486
-10	14	62.2756	30	86	7.97078	70	158	1.64691	110	230	0.47256
-9	16	58.7079	31	88	7.62411	71	160	1.59068	111	232	0.45957
-8	18	56.3694	32	90	7.29464	72	162	1.53668	112	234	0.44699
-7	19	52.2438	33	91	6.98142	73	163	1.48481	113	235	0.43482
-6	21	49.3161	34	93	6.68355	74	165	1.43498	114	237	0.42304
-5	23	46.5725	35	95	6.40021	75	167	1.38703	115	239	0.41164
-4	25	44	36	97	6.13059	76	169	1.34105	116	241	0.4006
-3	27	41.5878	37	99	5.87359	77	171	1.29078	117	243	0.38991
-2	28	39.8239	38	100	5.62961	78	172	1.25423	118	244	0.37956
-1	30	37.1988	39	102	5.39689	79	174	1.2133	119	246	0.36954
0	32	35.2024	40	104	5.17519	80	176	1.17393	120	248	0.35982
1	34	33.3269	41	106	4.96392	81	178	1.13604	121	250	0.35042
2	36	31.5635	42	108	4.76253	82	180	1.09958	122	252	0.3413
3	37	29.9058	43	109	4.5705	83	181	1.06448	123	253	0.33246
4	39	28.3459	44	111	4.38736	84	183	1.03069	124	255	0.3239
5	41	26.8778	45	113	4.21263	85	185	0.99815	125	257	0.31559
6	43	25.4954	46	115	4.04589	86	187	0.96681	126	259	0.30754
7	45	24.1932	47	117	3.88673	87	189	0.93662	127	261	0.29974
8	46	22.5662	48	118	3.73476	88	190	0.90753	128	262	0.29216
9	48	21.8094	49	120	3.58962	89	192	0.8795	129	264	0.28482
10	50	20.7184	50	122	3.45097	90	194	0.85248	130	266	0.2777
11	52	19.6891	51	124	3.31847	91	196	0.82643	131	268	0.27078
12	54	18.7177	52	126	3.19183	92	198	0.80132	132	270	0.26408
13	55	17.8005	53	127	3.07075	93	199	0.77709	133	271	0.25757
14	57	16.9341	54	129	2.95896	94	201	0.75373	134	273	0.25125
15	59	16.1156	55	131	2.84421	95	203	0.73119	135	275	0.24512
16	61	15.3418	56	133	2.73823	96	205	0.70944	136	277	0.23916
17	63	14.6181	57	135	2.63682	97	207	0.68844	137	279	0.23338
18	64	13.918	58	136	2.53973	98	208	0.66818	138	280	0.22776
19	66	13.2631	59	138	2.44677	99	210	0.64862	139	282	0.22231

ii) Temperature Sensor Resistance Value Table for TP(for some units) (°C --K)

°C	°F	K Ohm	°C	°F	K Ohm	°C	°F	K Ohm	°C	°F	K Ohm
°C	°F	K Ohm	°C	°F	K Ohm	°C	°F	K Ohm	°C	°F	K Ohm
-20	-4	542.7	20	68	68.66	60	140	13.59	100	212	3.702
-19	-2	511.9	21	70	65.62	61	142	13.11	101	214	3.595
-18	0	483	22	72	62.73	62	144	12.65	102	216	3.492
-17	1	455.9	23	73	59.98	63	145	12.21	103	217	3.392
-16	3	430.5	24	75	57.37	64	147	11.79	104	219	3.296
-15	5	406.7	25	77	54.89	65	149	11.38	105	221	3.203
-14	7	384.3	26	79	52.53	66	151	10.99	106	223	3.113
-13	9	363.3	27	81	50.28	67	153	10.61	107	225	3.025
-12	10	343.6	28	82	48.14	68	154	10.25	108	226	2.941
-11	12	325.1	29	84	46.11	69	156	9.902	109	228	2.86
-10	14	307.7	30	86	44.17	70	158	9.569	110	230	2.781
-9	16	291.3	31	88	42.33	71	160	9.248	111	232	2.704
-8	18	275.9	32	90	40.57	72	162	8.94	112	234	2.63
-7	19	261.4	33	91	38.89	73	163	8.643	113	235	2.559
-6	21	247.8	34	93	37.3	74	165	8.358	114	237	2.489
-5	23	234.9	35	95	35.78	75	167	8.084	115	239	2.422
-4	25	222.8	36	97	34.32	76	169	7.82	116	241	2.357
-3	27	211.4	37	99	32.94	77	171	7.566	117	243	2.294
-2	28	200.7	38	100	31.62	78	172	7.321	118	244	2.233
-1	30	190.5	39	102	30.36	79	174	7.086	119	246	2.174
0	32	180.9	40	104	29.15	80	176	6.859	120	248	2.117
1	34	171.9	41	106	28	81	178	6.641	121	250	2.061
2	36	163.3	42	108	26.9	82	180	6.43	122	252	2.007
3	37	155.2	43	109	25.86	83	181	6.228	123	253	1.955
4	39	147.6	44	111	24.85	84	183	6.033	124	255	1.905
5	41	140.4	45	113	23.89	85	185	5.844	125	257	1.856
6	43	133.5	46	115	22.89	86	187	5.663	126	259	1.808
7	45	127.1	47	117	22.1	87	189	5.488	127	261	1.762
8	46	121	48	118	21.26	88	190	5.32	128	262	1.717
9	48	115.2	49	120	20.46	89	192	5.157	129	264	1.674
10	50	109.8	50	122	19.69	90	194	5	130	266	1.632
11	52	104.6	51	124	18.96	91	196	4.849			
12	54	99.69	52	126	18.26	92	198	4.703			
13	55	95.05	53	127	17.58	93	199	4.562			
14	57	90.66	54	129	16.94	94	201	4.426			
15	59	86.49	55	131	16.32	95	203	4.294			
16	61	82.54	56	133	15.73	96	205	4.167			
17	63	78.79	57	135	15.16	97	207	4.045			
18	64	75.24	58	136	14.62	98	208	3.927			
19	66	71.86	59	138	14.09	99	210	3.812			

iii) Pressure On Service Port

Cooling chart(R410A):

°F(°C)	ODU(DB)		0(-17)	5(-15)	15 (-9.44)	45 (7.22)	75 (23.89)	85 (29.44)	95 (35)	105 (40.56)	115 (46.11)	120 (48.89)
	IDU(DB/WB)											
BAR	70/59 (21.11/15)		6.4	6.5	7.3	8.0	8.2	7.8	8.1	8.6	10.1	10.6
	75/63 (23.89/17.22)		6.7	6.8	7.9	8.6	8.6	8.3	8.7	9.1	10.7	11.2
	80/67 (26.67/19.44)		7.1	7.2	8.5	9.5	9.3	8.9	9.1	9.6	11.2	11.9
	90/73 (32.22/22.78)		7.7	7.8	9.6	10.5	10.3	9.5	10.0	10.6	12.4	13.0
PSI	70/59 (21.11/15)		93	94	106	116	119	113	117	125	147	154
	75/63 (23.89/17.22)		97	99	115	125	124	120	126	132	155	162
	80/67 (26.67/19.44)		103	104	123	138	135	129	132	140	162	173
	90/73 (32.22/22.78)		112	113	139	152	149	138	145	154	180	189
MPa	70/59 (21.11/15)		0.64	0.65	0.73	0.8	0.82	0.78	0.81	0.86	1.01	1.06
	75/63 (23.89/17.22)		0.67	0.68	0.79	0.86	0.86	0.83	0.87	0.91	1.07	1.12
	80/67 (26.67/19.44)		0.71	0.72	0.85	0.95	0.93	0.89	0.91	0.96	1.12	1.19
	90/73 (32.22/22.78)		0.77	0.78	0.96	1.05	1.03	0.95	1	1.06	1.24	1.3

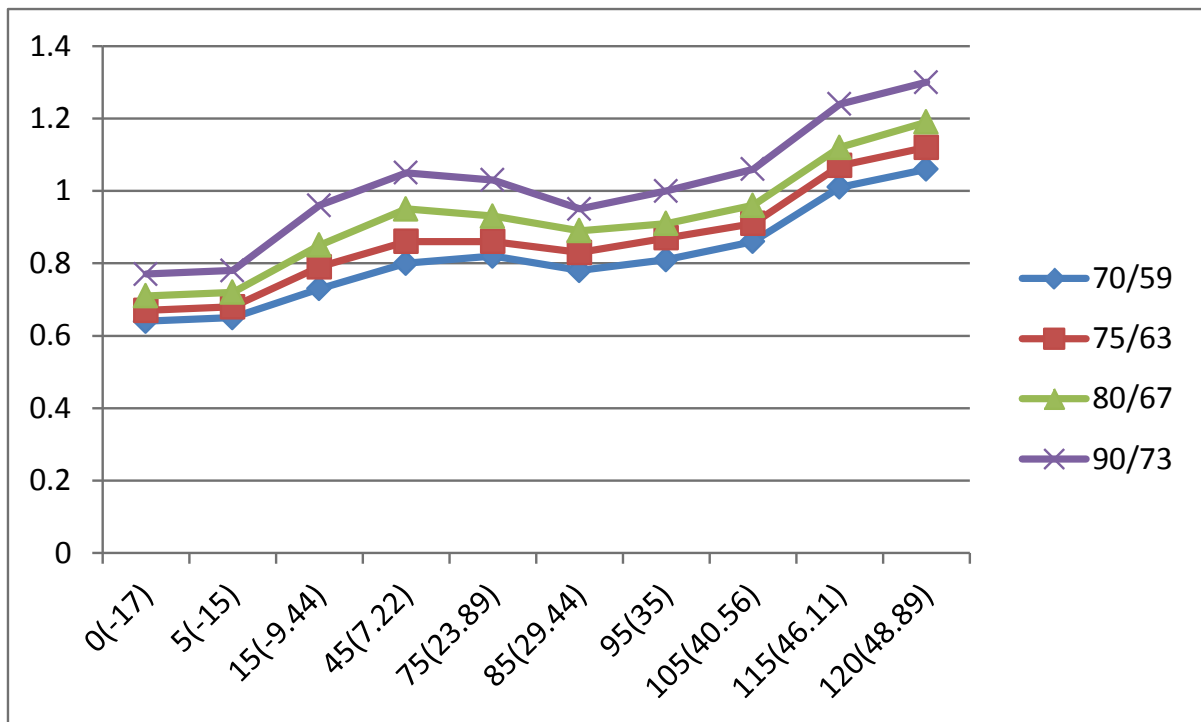

Heating chart(R410A):

°F(°C)	ODU(DB/WB)	57/53 (13.89/11.67)	47/43 (8.33/6.11)	37/33 (2.78/0.56)	27/23 (-2.78/-5)	17/13 (-8.33/ -10.56)	0/-2 (-17/-19)	-17/-18 (-27/-28)
	IDU(DB)							
BAR	55(12.78)	30.3	28.5	25.3	22.8	20.8	18.5	16.5
	65(18.33)	32.5	30.0	26.6	25.4	23.3	20.5	19.0
	75(23.89)	33.8	31.5	27.8	26.3	24.9	21.5	20.0
PSI	55(12.78)	439	413	367	330	302	268	239
	65(18.33)	471	435	386	368	339	297	276
	75(23.89)	489	457	403	381	362	312	290
MPa	55(12.78)	3.03	2.85	2.53	2.28	2.08	1.85	1.65
	65(18.33)	3.25	3.00	2.66	2.54	2.33	2.05	1.90
	75(23.89)	3.38	3.15	2.78	2.63	2.49	2.15	2.00

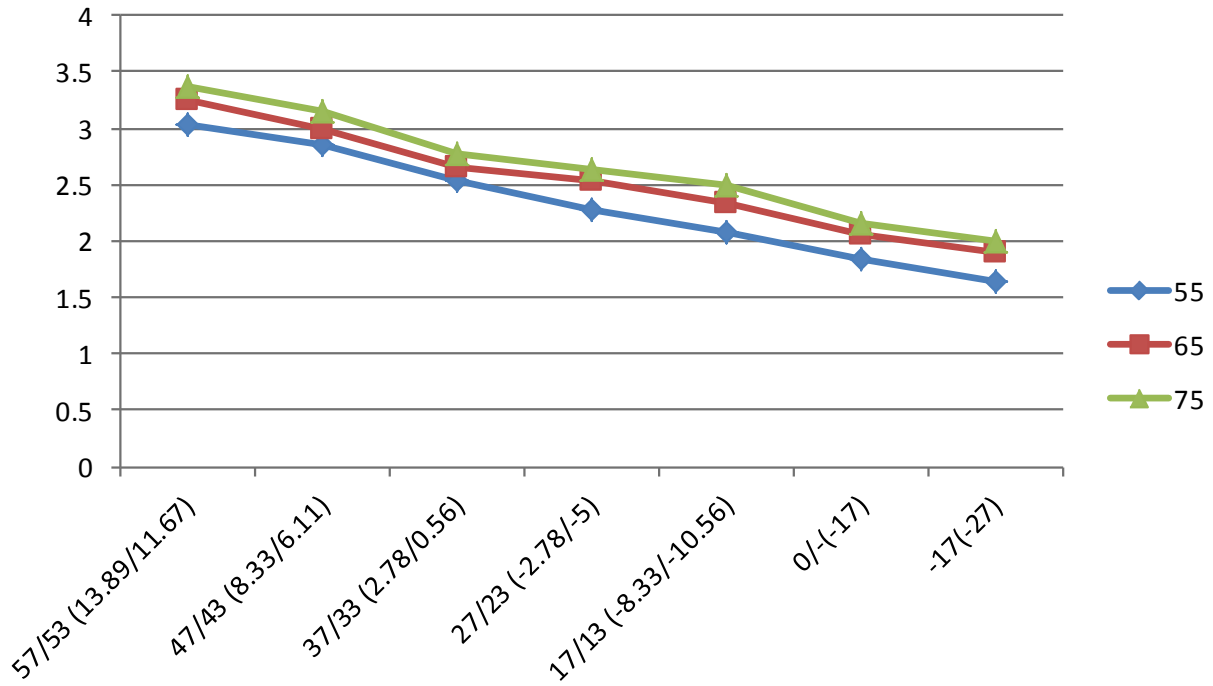

Cooling chart(R22):

°F(°C)	ODU(DB)		0(-17)	5(-15)	15(-9.44)	45(7.22)	75(23.89)	85(29.44)	95(35)	105(40.56)	115(46.11)	120(48.89)
	IDU(DB/WB)											
BAR	70/59 (21.11/15)		4.0	4.1	4.6	5.0	5.1	4.9	5.1	5.4	6.3	6.6
	75/63 (23.89/17.22)		4.2	4.3	4.9	5.4	5.4	5.2	5.4	5.7	6.7	7.0
	80/67 (26.67/19.44)		4.4	4.5	5.3	5.9	5.8	5.6	5.7	6.0	7.0	7.4
	90/73 (32.22/22.78)		4.8	4.9	6.0	6.6	6.4	5.9	6.3	6.6	7.8	8.1
PSI	70/59 (21.11/15)		58	59	67	73	74	71	74	78	91	96
	75/63 (23.89/17.22)		61	62	71	78	78	75	78	83	97	102
	80/67 (26.67/19.44)		64	65	77	86	84	81	83	87	102	107
	90/73 (32.22/22.78)		70	71	87	96	93	86	91	96	113	117
MPa	70/59 (21.11/15)		0.40	0.41	0.46	0.50	0.51	0.49	0.51	0.54	0.63	0.66
	75/63 (23.89/17.22)		0.42	0.43	0.49	0.54	0.54	0.52	0.54	0.57	0.67	0.70
	80/67 (26.67/19.44)		0.44	0.45	0.53	0.59	0.58	0.56	0.57	0.60	0.70	0.74
	90/73 (32.22/22.78)		0.48	0.49	0.60	0.66	0.64	0.59	0.63	0.66	0.78	0.81

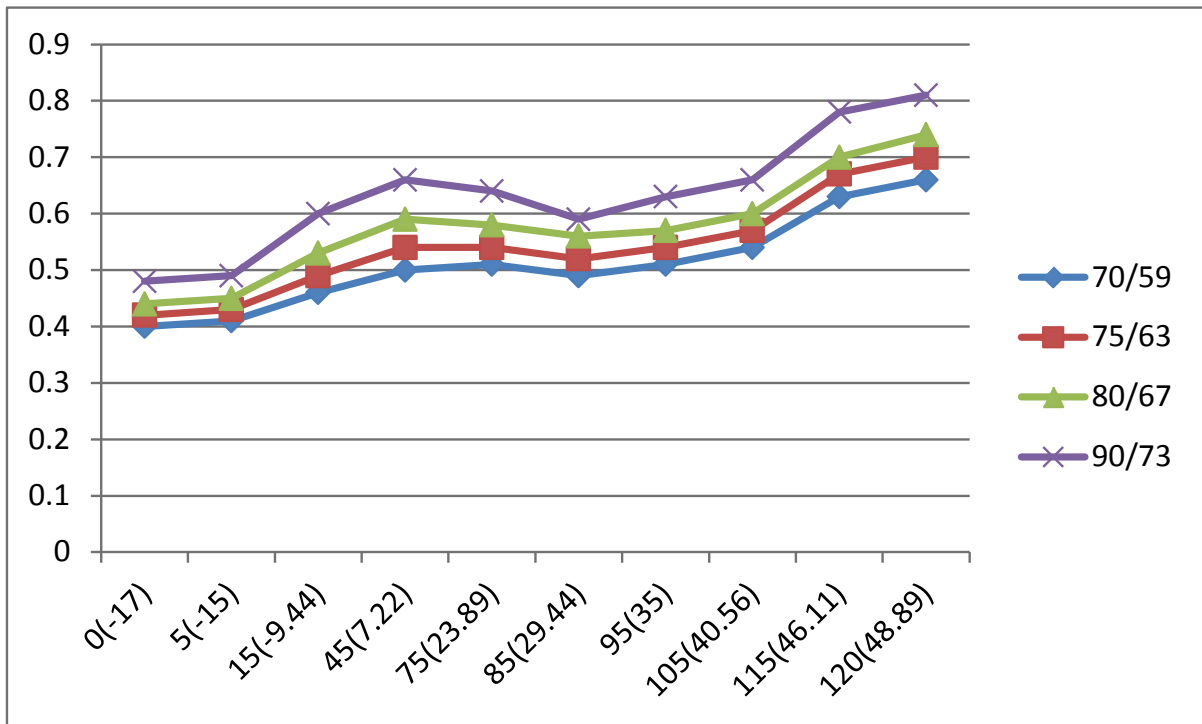

Heating chart(R22):

°F(°C)	ODU(DB/WB)	57/53 (13.89/11.67)	47/43 (8.33/6.11)	37/33 (2.78/0.56)	27/23 (-2.78/-5)	17/13 (-8.33/ -10.56)	0/-2 (-17/-19)	-17/-18 (-27/-28)
	IDU(DB)							
BAR	55(12.78)	18.9	17.8	15.8	14.3	13.0	11.6	10.3
	65(18.33)	20.3	18.8	16.6	15.9	14.6	12.8	11.9
	75(23.89)	21.1	19.7	17.3	16.4	15.6	13.4	12.5
PSI	55(12.78)	274	258	229	207	189	168	149
	65(18.33)	294	273	241	231	212	186	172.6
	75(23.89)	306	286	251	238	226	194	181
MPa	55(12.78)	1.89	1.78	1.58	1.43	1.30	1.16	1.03
	65(18.33)	2.03	1.88	1.66	1.59	1.46	1.28	1.19
	75(23.89)	2.11	1.97	1.73	1.64	1.56	1.34	1.25

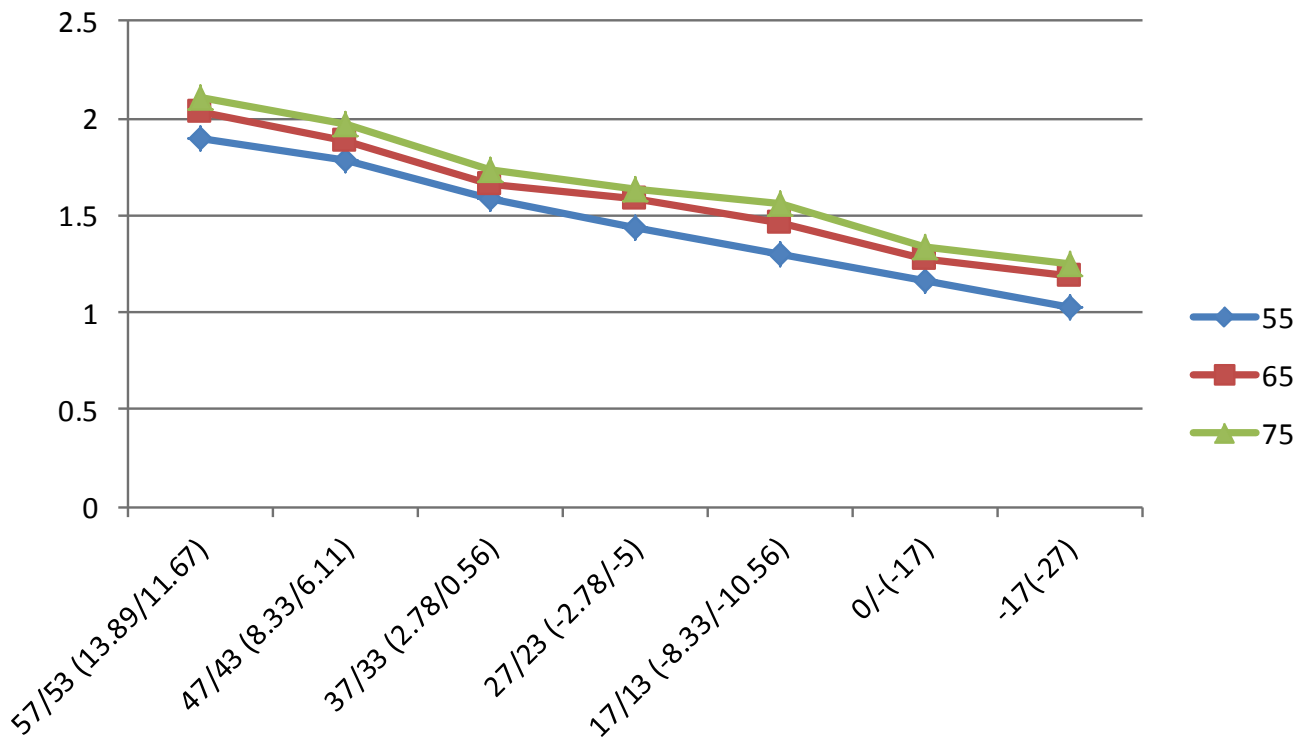

Cooling chart(R32):

°F(°C)	ODU(DB)		0(-17)	5(-15)	15(-9.44)	45(7.22)	75(23.89)	85(29.44)	95(35)	105(40.56)	115(46.11)	120(48.89)
	IDU(DB/WB)											
BAR	70/59 (21.11/15)		6.5	6.6	7.4	8.2	8.4	8.0	8.3	8.8	10.3	10.8
	75/63 (23.89/17.22)		6.8	6.9	8.1	8.8	8.8	8.5	8.9	9.3	10.9	11.4
	80/67 (26.67/19.44)		7.2	7.3	8.7	9.7	9.5	9.1	9.3	9.8	11.4	12.1
	90/73 (32.22/22.78)		7.9	8.0	9.8	10.7	10.5	9.7	10.2	10.8	12.6	13.3
PSI	70/59 (21.11/15)		95	96	108	118	121	115	119	128	150	157
	75/63 (23.89/17.22)		99	101	117	128	126	122	129	135	158	165
	80/67 (26.67/19.44)		105	106	125	141	138	132	135	143	165	176
	90/73 (32.22/22.78)		114	115	142	155	152	141	148	157	184	193
MPa	70/59 (21.11/15)		0.65	0.66	0.74	0.82	0.84	0.80	0.83	0.88	1.03	1.08
	75/63 (23.89/17.22)		0.68	0.69	0.81	0.88	0.88	0.85	0.89	0.93	1.09	1.14
	80/67 (26.67/19.44)		0.72	0.73	0.87	0.97	0.95	0.91	0.93	0.98	1.14	1.21
	90/73 (32.22/22.78)		0.79	0.80	0.98	1.07	1.05	0.97	1.02	1.08	1.26	1.33

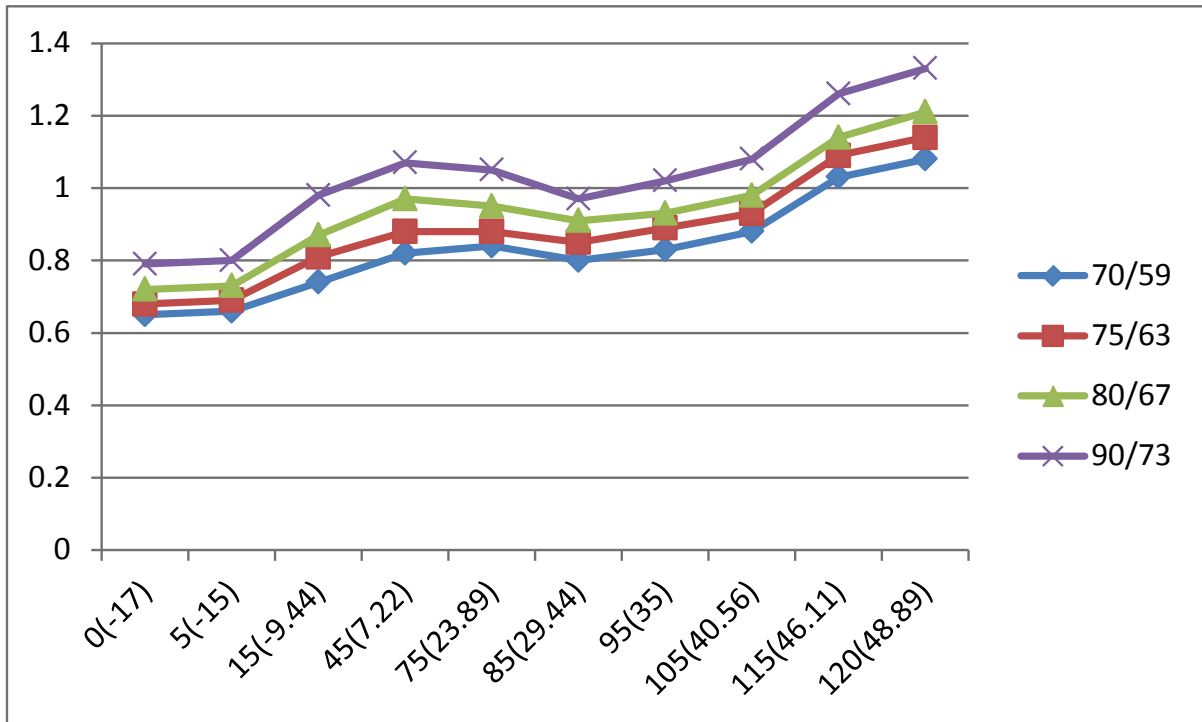

Heating chart(R32):

°F(°C)	ODU(DB/WB)	57/53 (13.89/11.67)	47/43 (8.33/6.11)	37/33 (2.78/0.56)	27/23 (-2.78/-5)	17/13 (-8.33/ -10.56)	0/-2 (-17/-19)	-17/-18 (-27/-28)
	IDU(DB)							
BAR	55(12.78)	30.9	29.1	25.8	23.3	21.2	18.9	16.8
	65(18.33)	33.2	30.6	27.1	25.9	23.8	20.9	19.4
	75(23.89)	34.5	32.1	28.4	26.8	25.4	21.9	20.4
PSI	55(12.78)	448	421	374	337	308	273	244
	65(18.33)	480	444	394	375	346	303	282
	75(23.89)	499	466	411	389	369	318	296
MPa	55(12.78)	3.09	2.91	2.58	2.33	2.12	1.89	1.68
	65(18.33)	3.32	3.06	2.71	2.59	2.38	2.09	1.94
	75(23.89)	3.45	3.21	2.84	2.68	2.54	2.19	2.04

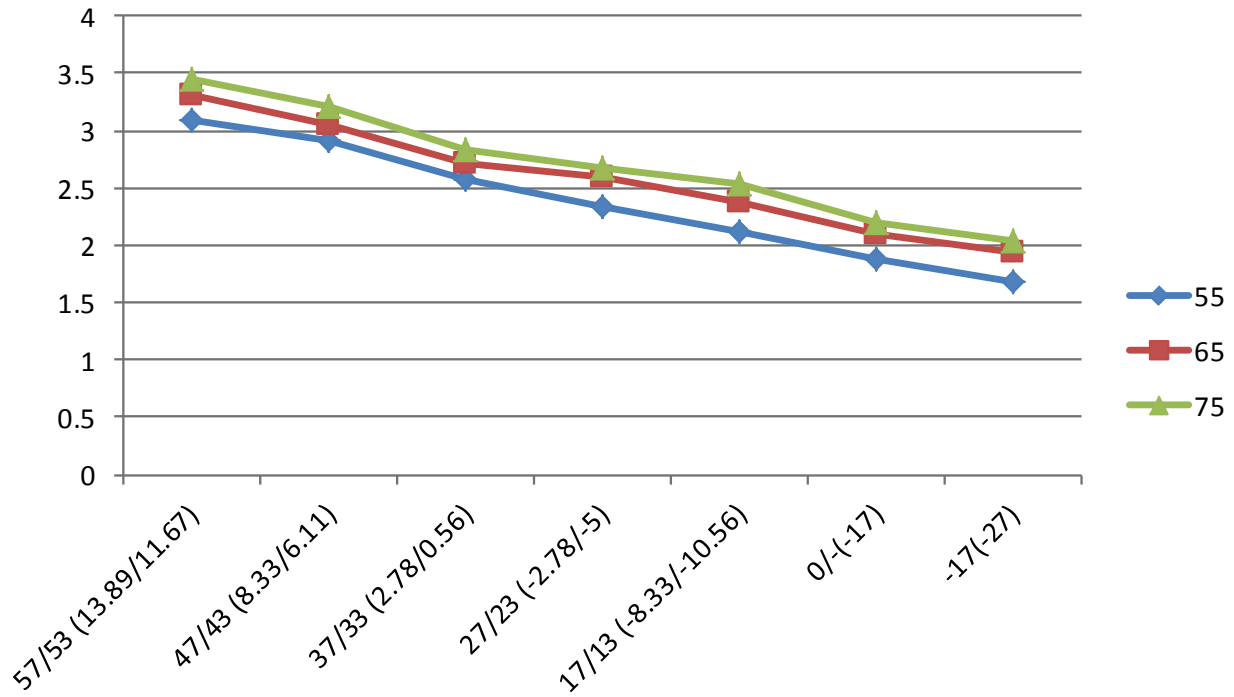

System Pressure Table-R22

Pressure			Temperature		Pressure			Temperature	
Kpa	bar	PSI	°C	°F	Kpa	bar	PSI	°C	°F
100	1	14.5	-41.091	-41.964	1600	16	232	41.748	107.146
150	1.5	21.75	-32.077	-25.739	1650	16.5	239.25	43.029	109.452
200	2	29	-25.177	-13.319	1700	17	246.5	44.281	111.706
250	2.5	36.25	-19.508	-3.114	1750	17.5	253.75	45.506	113.911
300	3	43.5	-14.654	5.623	1800	18	261	46.706	116.071
350	3.5	50.75	-10.384	13.309	1850	18.5	268.25	47.882	118.188
400	4	58	-6.556	20.199	1900	19	275.5	49.034	120.261
450	4.5	65.25	-3.075	26.464	1950	19.5	282.75	50.164	122.295
500	5	72.5	0.124	32.223	2000	20	290	51.273	124.291
550	5.5	79.75	3.091	37.563	2050	20.5	297.25	52.361	126.250
600	6	87	5.861	42.550	2100	21	304.5	53.43	128.174
650	6.5	94.25	8.464	47.234	2150	21.5	311.75	54.48	130.064
700	7	101.5	10.92	51.656	2200	22	319	55.512	131.922
750	7.5	108.75	13.249	55.848	2250	22.5	326.25	56.527	133.749
800	8	116	15.465	59.837	2300	23	333.5	57.526	135.547
850	8.5	123.25	17.58	63.644	2350	23.5	340.75	58.508	137.314
900	9	130.5	19.604	67.287	2400	24	348	59.475	139.055
950	9.5	137.75	21.547	70.785	2450	24.5	355.25	60.427	140.769
1000	10	145	23.415	74.147	2500	25	362.5	61.364	142.455
1050	10.5	152.25	25.216	77.389	2550	25.5	369.75	62.288	144.118
1100	11	159.5	26.953	80.515	2600	26	377	63.198	145.756
1150	11.5	166.75	28.634	83.541	2650	26.5	384.25	64.095	147.371
1200	12	174	30.261	86.470	2700	27	391.5	64.98	148.964
1250	12.5	181.25	31.839	89.310	2750	27.5	398.75	65.852	150.534
1300	13	188.5	33.371	92.068	2800	28	406	66.712	152.082
1350	13.5	195.75	34.86	94.748	2850	28.5	413.25	67.561	153.610
1400	14	203	36.308	97.354	2900	29	420.5	68.399	155.118
1450	14.5	210.25	37.719	99.894	2950	29.5	427.75	69.226	156.607
1500	15	217.5	39.095	102.371	3000	30	435	70.042	158.076
1550	15.5	224.75	40.437	104.787					

System Pressure Table-R410A

Pressure			Temperature		Pressure			Temperature	
Kpa	bar	PSI	°C	°F	Kpa	bar	PSI	°C	°F
100	1	14.5	-51.623	-60.921	2350	23.5	340.75	38.817	101.871
150	1.5	21.75	-43.327	-45.989	2400	24	348	39.68	103.424
200	2	29	-36.992	-34.586	2450	24.5	355.25	40.531	104.956
250	2.5	36.25	-31.795	-25.231	2500	25	362.5	41.368	106.462
300	3	43.5	-27.351	-17.232	2550	25.5	369.75	42.192	107.946
350	3.5	50.75	-23.448	-10.206	2600	26	377	43.004	109.407
400	4	58	-19.953	-3.915	2650	26.5	384.25	43.804	110.847
450	4.5	65.25	-16.779	1.798	2700	27	391.5	44.592	112.266
500	5	72.5	-13.863	7.047	2750	27.5	398.75	45.37	113.666
550	5.5	79.75	-11.162	11.908	2800	28	406	46.136	115.045
600	6	87	-8.643	16.444	2850	28.5	413.25	46.892	116.406
650	6.5	94.25	-6.277	20.701	2900	29	420.5	47.638	117.748
700	7	101.5	-4.046	24.716	2950	29.5	427.75	48.374	119.073
750	7.5	108.75	-1.933	28.521	3000	30	435	49.101	120.382
800	8	116	0.076	32.137	3050	30.5	442.25	49.818	121.672
850	8.5	123.25	1.993	35.587	3100	31	449.5	50.525	122.945
900	9	130.5	3.826	38.888	3150	31.5	456.75	51.224	124.203
950	9.5	137.75	5.584	42.052	3200	32	464	51.914	125.445
1000	10	145	7.274	45.093	3250	32.5	471.25	52.596	126.673
1050	10.5	152.25	8.901	48.022	3300	33	478.5	53.27	127.886
1100	11	159.5	10.471	50.848	3350	33.5	485.75	53.935	129.083
1150	11.5	166.75	11.988	53.578	3400	34	493	54.593	130.267
1200	12	174	13.457	56.223	3450	34.5	500.25	55.243	131.437
1250	12.5	181.25	14.879	58.782	3500	35	507.5	55.885	132.593
1300	13	188.5	16.26	61.268	3550	35.5	514.75	56.52	133.736
1350	13.5	195.75	17.602	63.684	3600	36	522	57.148	134.866
1400	14	203	18.906	66.031	3650	36.5	529.25	57.769	135.984
1450	14.5	210.25	20.176	68.317	3700	37	536.5	58.383	137.089
1500	15	217.5	21.414	70.545	3750	37.5	543.75	58.99	138.182
1550	15.5	224.75	22.621	72.718	3800	38	551	59.591	139.264
1600	16	232	23.799	74.838	3850	38.5	558.25	60.185	140.333
1650	16.5	239.25	24.949	76.908	3900	39	565.5	60.773	141.391
1700	17	246.5	26.074	78.933	3950	39.5	572.75	61.355	142.439
1750	17.5	253.75	27.174	80.913	4000	40	580	61.93	143.474
1800	18	261	28.251	82.852	4050	40.5	587.25	62.499	144.498
1850	18.5	268.25	29.305	84.749	4100	41	594.5	63.063	145.513
1900	19	275.5	30.338	86.608	4150	41.5	601.75	63.62	146.516
1950	19.5	282.75	31.351	88.432	4200	42	609	64.172	147.510
2000	20	290	32.344	90.219	4250	42.5	616.25	64.719	148.494
2050	20.5	297.25	33.319	91.974	4300	43	623.5	65.259	149.466
2100	21	304.5	34.276	93.697	4350	43.5	630.75	65.795	150.431
2150	21.5	311.75	35.215	95.387	4400	44	638	66.324	151.383
2200	22	319	36.139	97.050	4450	44.5	645.25	66.849	152.328
2250	22.5	326.25	37.047	98.685	4500	45	652.5	67.368	153.262
2300	23	333.5	37.939	100.290					

System Pressure Table-R32

Pressure			Temperature		Pressure			Temperature	
Kpa	bar	PSI	°C	°F	Kpa	bar	PSI	°C	°F
100	1	14.5	-51.909	-61.436	1850	18.5	268.25	28.425	83.165
150	1.5	21.75	-43.635	-46.543	1900	19	275.5	29.447	85.005
200	2	29	-37.323	-35.181	1950	19.5	282.75	30.448	86.806
250	2.5	36.25	-32.15	-25.87	2000	20	290	31.431	88.576
300	3	43.5	-27.731	-17.916	2050	20.5	297.25	32.395	90.311
350	3.5	50.75	-23.85	-10.93	2100	21	304.5	33.341	92.014
400	4	58	-20.378	-4.680	2150	21.5	311.75	34.271	93.688
450	4.5	65.25	-17.225	0.995	2200	22	319	35.184	95.331
500	5	72.5	-14.331	6.204	2250	22.5	326.25	36.082	96.948
550	5.5	79.75	-11.65	11.03	2300	23	333.5	36.965	98.537
600	6	87	-9.150	15.529	2350	23.5	340.75	37.834	100.101
650	6.5	94.25	-6.805	19.752	2400	24	348	38.688	101.638
700	7	101.5	-4.593	23.734	2450	24.5	355.25	39.529	103.152
750	7.5	108.75	-2.498	27.505	2500	25	362.5	40.358	104.644
800	8	116	-0.506	31.089	2550	25.5	369.75	41.173	106.111
850	8.5	123.25	1.393	34.507	2600	26	377	41.977	107.559
900	9	130.5	3.209	37.777	2650	26.5	384.25	42.769	108.984
950	9.5	137.75	4.951	40.911	2700	27	391.5	43.55	110.39
1000	10	145	6.624	43.923	2750	27.5	398.75	44.32	111.776
1050	10.5	152.25	8.235	46.823	2800	28	406	45.079	113.142
1100	11	159.5	9.790	49.621	2850	28.5	413.25	45.828	114.490
1150	11.5	166.75	11.291	52.324	2900	29	420.5	46.567	115.821
1200	12	174	12.745	54.941	2950	29.5	427.75	47.296	117.133
1250	12.5	181.25	14.153	57.475	3000	30	435	48.015	118.427
1300	13	188.5	15.52	59.936	3050	30.5	442.25	48.726	119.707
1350	13.5	195.75	16.847	62.325	3100	31	449.5	49.428	120.970
1400	14	203	18.138	64.648	3150	31.5	456.75	50.121	122.218
1450	14.5	210.25	19.395	66.911	3200	32	464	50.806	123.451
1500	15	217.5	20.619	69.114	3250	32.5	471.25	51.482	124.668
1550	15.5	224.75	21.813	71.263	3300	33	478.5	52.15	125.87
1600	16	232	22.978	73.360	3350	33.5	485.75	52.811	127.060
1650	16.5	239.25	24.116	75.409	3400	34	493	53.464	128.235
1700	17	246.5	25.229	77.412	3450	34.5	500.25	54.11	129.398
1750	17.5	253.75	26.317	79.371	3500	35	507.5	54.748	130.546
1800	18	261	27.382	81.288					